

February 21, 2020

14130 Version 4

Safety Recall: Ignition Coils

Supersedes 15-060, dated June 23, 2018, to revise the information highlighted in **yellow**.

AFFECTED VEHICLES

Year	Model	Trim	VIN Range
2015	Fit	ALL	Check the iN VIN status for eligibility

REVISION SUMMARY

Under WARRANTY CLAIM INFORMATION, information was removed.

BACKGROUND

The noise suppression capacitors inside the ignition coils may degrade over time causing the MIL to come on, the engine or fuel injection system to malfunction, or in severe cases, the engine to stall.

NOTE: If the MIL is on with DTC P0300 (random misfire detected) or P0301–P0304 (cylinder misfire detected), refer to service bulletin 16-034, *MIL Comes On with DTC P0300, P0301, P0302, P0303, P0304*, and do that procedure first. Then, make sure you do this bulletin to complete the repair.

CUSTOMER NOTIFICATION

Owners of affected vehicles will be sent a notification of this campaign.

Do an iN VIN status inquiry to make sure the vehicle is shown as eligible.

Some vehicles affected by this campaign may be in your new or used vehicle inventory. These vehicles must be repaired before they are sold.

Should a dealership sell an unrepaired vehicle that subsequently causes an injury or damage because of the recalled item, the dealership will be solely responsible to the damaged party, and will be required to defend and indemnify American Honda for any resulting claims. To see if a vehicle in inventory is affected by this campaign, do a VIN status inquiry before selling it.

CORRECTIVE ACTION

Replace the four ignition coils and, if necessary, clean the spark plug connection ends.

PARTS INFORMATION

Part Name	Part Number	Quantity
Ignition Coil	30520-5R0-013	4

CUSTOMER INFORMATION: The information in this bulletin is intended for use only by skilled technicians who have the proper tools, equipment, and training to correctly and safely maintain your vehicle. These procedures should not be attempted by “do-it-yourselfers,” and you should not assume this bulletin applies to your vehicle, or that your vehicle has the condition described. To determine whether this information applies, contact an authorized Honda automobile dealer.

WARRANTY CLAIM INFORMATION

Operation Number	Description	Flat Rate Time	Defect Code	Symptom Code	Template ID	Failed Part Number
1175A2	Replace the ignition coils and if necessary, clean the spark plug connection end.	0.4 hr	5YW00	JT900	15-060A	30520-5R0-003

Skill Level: Repair Technician

REPAIR PROCEDURE

1. Disconnect the ignition coil connectors.

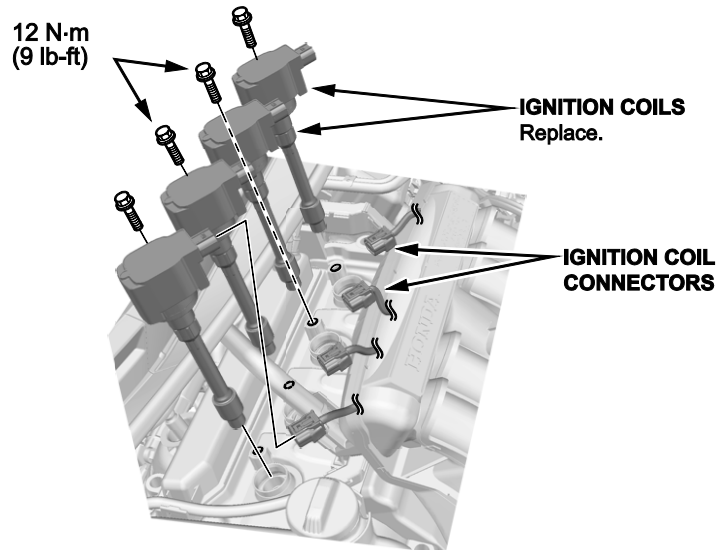

2. Remove the ignition coils.
3. Remove the spark plugs.

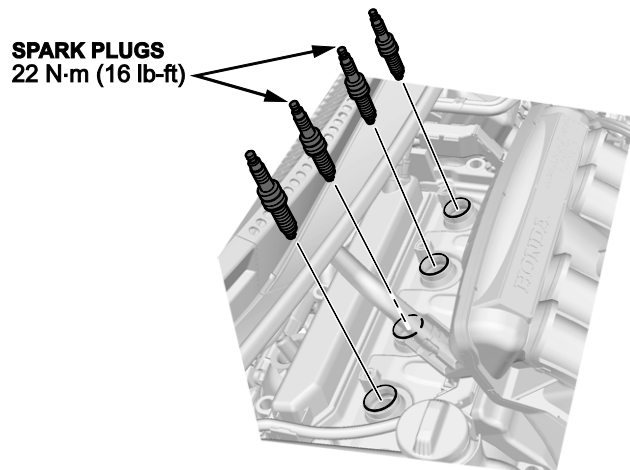

4. Inspect the connection end of the spark plugs.

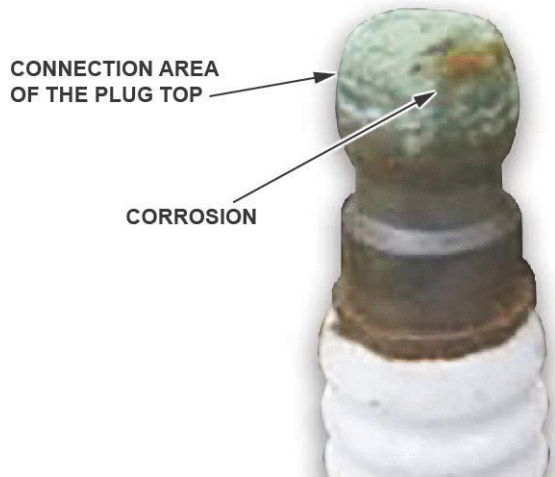

- If the spark plug connection ends have corrosion on them, clean them with a commercially available cleaner, then reinstall the spark plugs and torque them to **22 N·m (16 lb-ft)**.
 - If the spark plug connection ends does not have any corrosion on them, reinstall the spark plugs and torque them to **22 N·m (16 lb-ft)**.
5. Install the new ignition coils and torque them to **12 N·m (9 lb-ft)**.
6. *California residents only.* Fill out a Vehicle Emissions Recall – Proof of Correction certificate, and use JT9 as the recall number. Give the certificate to your customer, and advise him or her to keep it as proof that the recall was completed. Your customer will need to submit this certificate to the DMV only if the DMV requests it. If you need more certificates, use reorder number Y0657.

Vehicle Emission Recall - Proof of Correction				
License Number	Make	Year Model	Body Type	Vehicle Identification Number
Manufacturer			Recall Number JT9	
The above described vehicle has been repaired, modified and/or equipped with emission control devices to meet applicable California Emission Control Laws.				
Dealer's Name		Address, City, State and Zip		
Date	Dealership's Authorized Signature			
	X			
Return this certificate to DMV <u>only</u> when required - otherwise retain for your records.				

Y0657 ACL 24832 (0212)

END