



Service Bulletin

American Honda Motor Co., Inc.

SAFETY RECALL

MULTIPLE MODELS - STARTER RELAY SWITCH INSPECTION/REPLACEMENT

(This supersedes Starter Relay Switch #1, dated August 2015)

*This Service Bulletin has been revised to include the expanded VIN range of some affected models.
Revised information is indicated by a NEW bar adjacent to the text.*

Honda Motor Co., Ltd is conducting a Safety Recall of motorcycles and scooters listed in the **AFFECTED UNITS** section of this bulletin. Honda has determined that a defect within certain starter relay switch assemblies can cause an increase in resistance at the main fuse, potentially interrupting battery voltage to the electrical system which can cause the engine to A) not start or B) stall while riding. In an extreme case, the increased resistance at the main fuse may cause the starter relay switch to catch on fire.

A replacement starter relay switch is available to correct this condition in units that fail the inspection procedure.

Safety Consequence

An engine that stalls while riding increases the risk of a crash.

CUSTOMER NOTIFICATION

American Honda is sending a letter to owners of all affected motorcycles, informing them that their motorcycle/scooter is being recalled for a safety related defect. The customer will be made aware of the safety risk and advised to have a Honda dealer inspect and, if necessary, replace the starter relay switch.

For your reference, a copy of the Customer Letter is reproduced on pages 11 and 12 of this Service Bulletin.

NEW

Owners of affected motorcycles within the expanded VIN range will also receive recall notification letters.

MULTI-MODEL: STARTER RELAY SWITCH #1
REVISED: DECEMBER 2015

AFFECTED UNITS

Model	Model Year	Type	VIN Range	
CRF250L	2014	AC	MLHMD381*E5102773 thru	MLHMD381*E5107622
	2015	AC	MLHMD381*F5200001 thru	MLHMD381*F5202950
CB300F	2015	AC	MLHNC521*F5100001 thru	MLHNC521*F5102642
CBR300R	2015	NEW A, 2A, 8A	MLHNC510*F5100001 thru	MLHNC510*F5103186
		NEW AC, 3AC, 9AC	MLHNC511*F5100001 thru	MLHNC511*F5100666
CBR300RA	2015	NEW AC, 3AC, 9AC	MLHNC515*F5100001 thru	MLHNC515*F5101026
NSS300	2014	AC	MLHNF040*E5001971 thru	MLHNF040*E5001990
	2015	AC	MLHNF040*F5100001 thru	MLHNF040*F5100426
NSS300A	2014	AC	MLHNF041*E5000335 thru	MLHNF041*E5000346
	2015	AC	MLHNF041*F5100001 thru	MLHNF041*F5100278
CB500F	2014	NEW A, 3A	MLHPC456*E5101195 thru	MLHPC456*E5101374
		NEW AC, 2AC	MLHPC451*E5100179 thru	MLHPC451*E5100258
	2015	3A	MLHPC456*F5200001 thru	MLHPC456*F5200924
		2AC	MLHPC451*F5200001 thru	MLHPC451*F5200170
CB500FA	2014	NEW AC	MLHPC450*E5100233 thru	MLHPC450*E5100308
	2015	2AC	MLHPC450*F5200001 thru	MLHPC450*F5200296
CB500X	2014	NEW A	MLHPC466*E5100491 thru	MLHPC466*E5100884
		NEW AC	MLHPC461*E5100087 thru	MLHPC461*E5100166
	2015	A	MLHPC466*F5200001 thru	MLHPC466*F5200656
		AC	MLHPC461*F5200001 thru	MLHPC461*F5200132
CB500XA	2014	NEW AC	MLHPC460*E5100067 thru	MLHPC460*E5100164
	2015	AC	MLHPC460*F5200001 thru	MLHPC460*F5200226
CBR500R	2014	NEW A, 3A	MLHPC446*E5101021 thru	MLHPC446*E5102384
		NEW AC, 2AC	MLHPC441*E5100191 thru	MLHPC441*E5100446
	2015	A	MLHPC446*F5200001 thru	MLHPC446*F5201626
		AC	MLHPC441*F5200001 thru	MLHPC441*F5200339
CBR500RA	2014	NEW AC	MLHPC440*E5100193 thru	MLHPC440*E5100544
	2015	AC	MLHPC440*F5200001 thru	MLHPC440*F5200367
CBR600RR	2015	A	JH2PC400*FK800001 thru	JH2PC400*FK801445
		AC	JH2PC401*FK800001 thru	JH2PC401*FK800287
CBR600RA	2015	AC	JH2PC408*FK800001 thru	JH2PC408*FK800070
CBR650F	2014	A	MLHRC740*E5000001 thru	MLHRC740*E5001482
		AC	MLHRC741*E5000001 thru	MLHRC741*E5000271
	2015	A	MLHRC740*F5100001 thru	MLHRC740*F5100696
		AC	MLHRC741*F5100001 thru	MLHRC741*F5100144
CBR650FA	2014	AC	MLHRC745*E5000002 thru	MLHRC745*E5000268
	2015	AC	MLHRC745*F5100001 thru	MLHRC745*F5100112

* Denotes check digit.

**MULTI-MODEL: STARTER RELAY SWITCH #1
REVISED: DECEMBER 2015**

Model	Model Year	Type	VIN Range
CTX700	2014	A	JH2RC690*EK001401 thru JH2RC690*EK001459
		AC	JH2RC691*EK000145 thru JH2RC691*EK000150
	2015	A	JH2RC690*FK100001 thru JH2RC690*FK100348
		AC	JH2RC691*FK100001 thru JH2RC691*FK100060
CTX700D	2014	A	JH2RC694*EK000829 thru JH2RC694*EK001011
		AC	JH2RC695*EK000096 thru JH2RC695*EK000147
	2015	A	JH2RC694*FK100001 thru JH2RC694*FK100893
		AC	JH2RC695*FK100001 thru JH2RC695*FK100149
CTX700N	2015	A	JH2RC680*FK100001 thru JH2RC680*FK100418
		AC	JH2RC681*FK100001 thru JH2RC681*FK100062
CTX700ND	2015	A	JH2RC684*FK100001 thru JH2RC684*FK100888
		AC	JH2RC685*FK100001 thru JH2RC685*FK100134
NC700X	2014	A	JH2RC630*EK000001 thru JH2RC630*EK001394
		AC	JH2RC635*EK200001 thru JH2RC635*EK200246
	2015	A	JH2RC630*FK100001 thru JH2RC630*FK100957
		AC	JH2RC635*FK300001 thru JH2RC635*FK300166
NC700XD	2014	A	JH2RC634*EK000001 thru JH2RC634*EK000350
		AC	JH2RC631*EK200002 thru JH2RC631*EK200061
	2015	A	JH2RC634*FK100001 thru JH2RC634*FK100469
		AC	JH2RC631*FK300001 thru JH2RC631*FK300109
NC700JD	2015	AC	JH2RC811*FK000001 thru JH2RC811*FK000207
	2016	AC	JH2RC811*GK100001 thru JH2RC811*GK100174
VT750C	2014	A	JH2RC500*EK100004 thru JH2RC500*EK100471
		AC	JH2RC501*EK100001 thru JH2RC501*EK100053
	2015	A	JH2RC500*FK200001 thru JH2RC500*FK201363
		AC	JH2RC501*FK200001 thru JH2RC501*FK200146
VT750CA	2014	A	JH2RC504*EK900001 thru JH2RC504*EK900313
		AC	JH2RC505*EK900001 thru JH2RC505*EK900036
VT750C2	2014	A	JH2RC530*EK600004 thru JH2RC530*EK600381
		AC	JH2RC531*EK600001 thru JH2RC531*EK600039
VT750C2B	2014	A	JH2RC537*EK400004 thru JH2RC537*EK400845
		AC	JH2RC538*EK400001 thru JH2RC538*EK400105
	2015	A	JH2RC537*FK500001 thru JH2RC537*FK502563
		AC	JH2RC538*FK500001 thru JH2RC538*FK500337
VT750C2F	2014	A	JH2RC534*EK700001 thru JH2RC534*EK700282
		AC	JH2RC535*EK700001 thru JH2RC535*EK700029
ST1300PA	2013	AC	JH2SC515*DK100048 thru JH2SC515*DK100106
	2014	AC	JH2SC515*EK200003 thru JH2SC515*EK200141
	2015	AC	JH2SC515*FK300001 thru JH2SC515*FK300181

* Denotes check digit.

MULTI-MODEL: STARTER RELAY SWITCH #1
REVISED: DECEMBER 2015

Model	Model Year	Type	VIN Range
VT1300CX	2014	3A	JH2SC61N*EK200004 thru JH2SC61N*EK200647
		AC	JH2SC611*EK400001 thru JH2SC611*EK400035
	2015	3A	JH2SC61N*FK300001 thru JH2SC61N*FK300319
		4A	JH2SC61P*FK100001 thru JH2SC61P*FK100416
		5AC	JH2SC61V*FK100001 thru JH2SC61V*FK100036
		AC	JH2SC611*FK500001 thru JH2SC611*FK500213
VT1300CXA	2014	AC	JH2SC618*EK300001 thru JH2SC618*EK300018
	2015	2AC	JH2SC618*FK400001 thru JH2SC618*FK400018
VT1300CR	2014	A	JH2SC660*EK400004 thru JH2SC660*EK400233
		AC	JH2SC661*EK400001 thru JH2SC661*EK400011
	2015	A	JH2SC660*FK500001 thru JH2SC660*FK500838
		AC	JH2SC661*FK500001 thru JH2SC661*FK500044
VT1300CRA	2014	AC	JH2SC665*EK200001 thru JH2SC665*EK200007
	2015	AC	JH2SC665*FK300001 thru JH2SC665*FK300018
VT1300CT	2014	A	JH2SC667*EK400004 thru JH2SC667*EK400465
		AC	JH2SC668*EK400001 thru JH2SC668*EK400025
	2015	A	JH2SC667*FK500001 thru JH2SC667*FK500826
		AC	JH2SC668*FK500001 thru JH2SC668*FK500057
VT1300CTA	2014	AC	JH2SC66J*EK300001 thru JH2SC66J*EK300015
	2015	AC	JH2SC66J*FK400001 thru JH2SC66J*FK400017

* Denotes check digit.

DEALER INVENTORY

Do not sell any un-repaired units.

According to federal law, any affected units in your new inventory cannot be sold or leased until they are inspected or repaired with a replacement starter relay switch, and Honda policy prohibits the sale of new or used un-repaired units. To identify affected units in your inventory, refer to *Unit Information* and your *eResponsibility Report* on **iN**. Then proceed with the **REPAIR VERIFICATION** section of this Service Bulletin.

REPAIR VERIFICATION

Before you begin the Inspection Procedure, check if the inspection/repair has been performed on the unit. Some units within the affected VIN range may have been factory-repaired. See the **IDENTIFICATION** section of

this Service Bulletin for punch mark locations.

- If there is a punch mark:
 - No further action is necessary
- If there is no punch mark:
 - You must proceed with the **INSPECTION PROCEDURE** section of this Service Bulletin.

INSPECTION PROCEDURE

Service Manual

To complete the Inspection Procedure use the model specific Service Manual. Service Manuals are also available on **iN** HISP by following the path below and typing in the VIN or selecting the model and year, and selecting *Service Manual* from the *Select Subject* drop down list.

SERVICE > Service Publications > HISP

Inspection Procedure

1. Refer to the BATTERY/CHARGING SYSTEM section of the Service Manual and disconnect the battery negative (-) cable.
2. Refer to the ELECTRIC STARTER section of the Service Manual and locate the starter relay switch.
3. Inspect the four character lot number on the underside of the starter relay switch as shown and record it on the R/O.

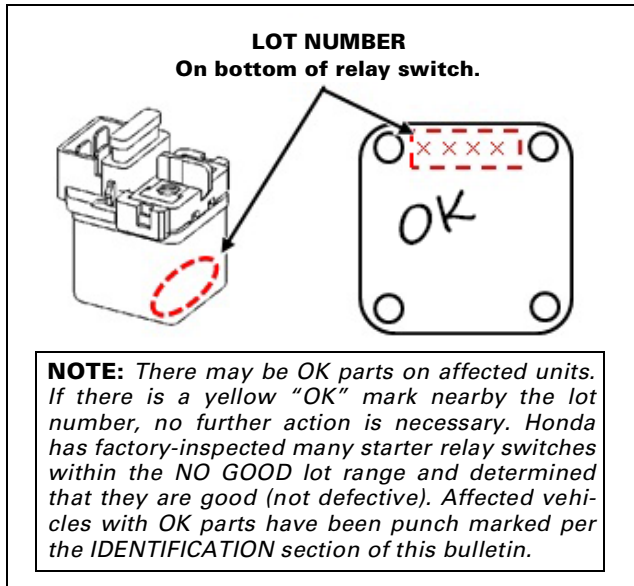

4. Determine if the lot number is within the range of NO GOOD starter relay switches by comparing the lot number to the information below:

Reading the Lot Number

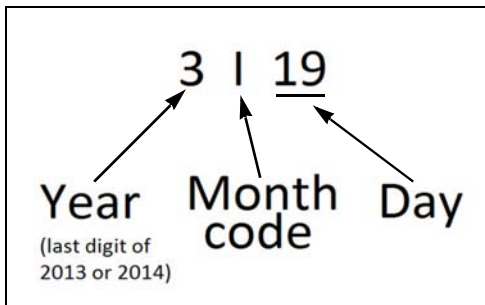

Decoding the Lot Number

for Example:
 Lot No. 3I19 ⇒ Year: 2013, Month: September, Day: 19

3	I	19						
↑	↑	↑						
Year	Month	Day						
	Month		Jan	Feb	Mar	Apr	May	Jun
			A	B	C	D	E	F
			Jul	Aug	Sep	Oct	Nov	Dec
			G	H	I	J	K	L

Year: the last digit of the year.

NO GOOD Lot Numbers

3I19 through 4I01

(Parts manufactured from September 19, 2013 through September 1, 2014)

Any lot number within the NO GOOD range is potentially defective (unless marked OK) and must be replaced. Any lot number outside that range is OK.

- If the starter relay switch is OK:
 - Reinstall the relay switch and then connect the battery negative (-) cable.
 - Proceed to the IDENTIFICATION section of this bulletin, follow the instructions for the model at hand and apply the punch mark to the unit.
 - File a warranty claim using the chart in the CLAIM and PARTS INFORMATION section of this bulletin.
- If the starter relay switch is NO GOOD:
 - Proceed to the REPAIR PROCEDURE section of this bulletin.

MULTI-MODEL: STARTER RELAY SWITCH #1

REVISED: DECEMBER 2015

REPAIR PROCEDURE

Proceed with this section only after determining that the starter relay switch requires replacement, as shown in the [INSPECTION PROCEDURE](#).

1. Refer to the [CLAIM and PARTS INFORMATION](#) section of this bulletin to find the correct replacement part number for the model being repaired.
2. Refer to the ELECTRIC STARTER section of the Service Manual and remove the starter relay switch.
3. Carefully inspect the starter relay switch 4P (Red) connector (wire harness side) for any damage (melted, burned).



- If the connector is damaged, call Tech-Line for further instructions.
 - If the connector is OK, proceed to Step 4.
4. Replace the starter relay switch with the new part.
Make sure the 30 A (Green) fuse is installed in the top of the relay switch assembly. *Do not use the 20 A or 15 A fuses supplied in the repair parts kit.*
 5. Reconnect the battery negative (-) cable.
 6. Confirm the repair by turning the ignition switch to ON and starting the engine.
 - If there is a problem, check that the correct starter relay switch repair kit was used.
 7. Proceed to the [IDENTIFICATION](#) section of this bulletin.

IDENTIFICATION

After you have completed the inspection (starter relay switch OK) or inspection/repair procedure (starter relay switch replaced), find the affected model below and follow the instructions.

NSS300/A

Place a punch mark after the last character of the frame serial number, stamped on the rear of the frame inside the luggage box as shown.

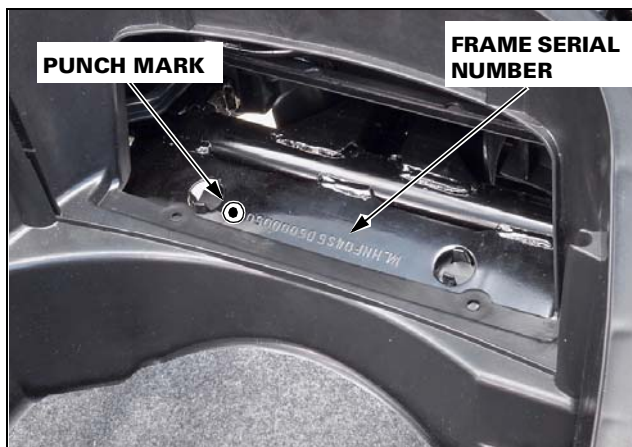

CB300F

Place a punch mark on the frame, next to the Safety Certification Label, nearby the VIN as shown.



CRF250L*, CBR300R/RA, CBR600RR/RA

Place a punch mark after the last character of the stamped frame serial number as shown.

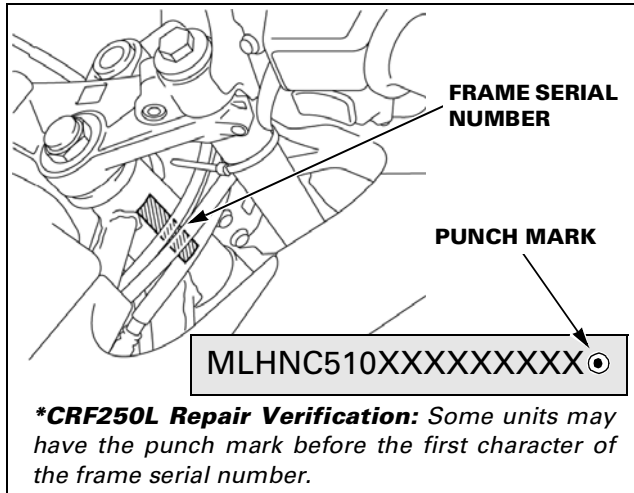

CB500F/FA

Place a punch mark on the frame, next to the Safety Certification Label, nearby the VIN as shown.

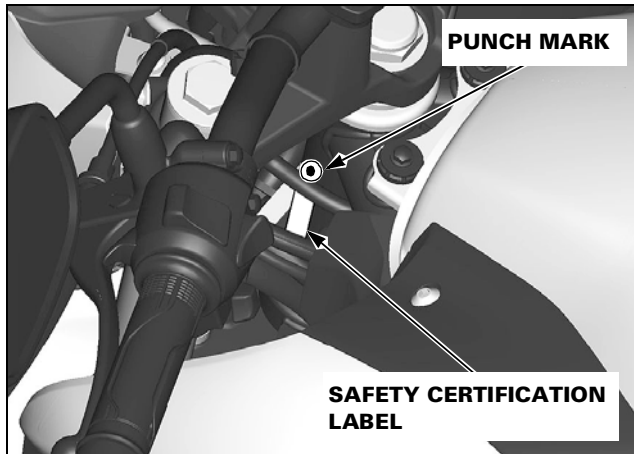

CB500X/XA

Place a punch mark on the frame, next to the Safety Certification Label, nearby the VIN as shown.

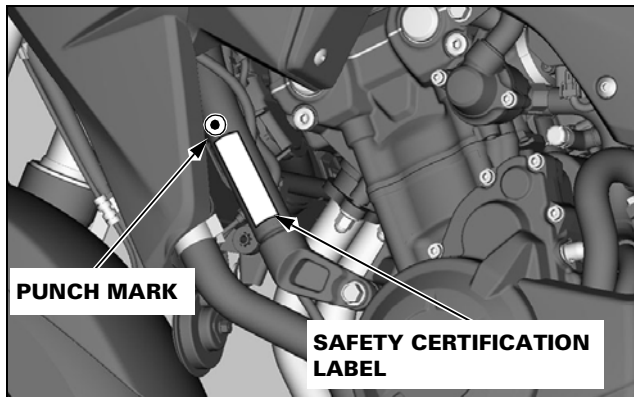

CBR500R/RA

Place a punch mark on the engine before the first character of the engine number as shown.

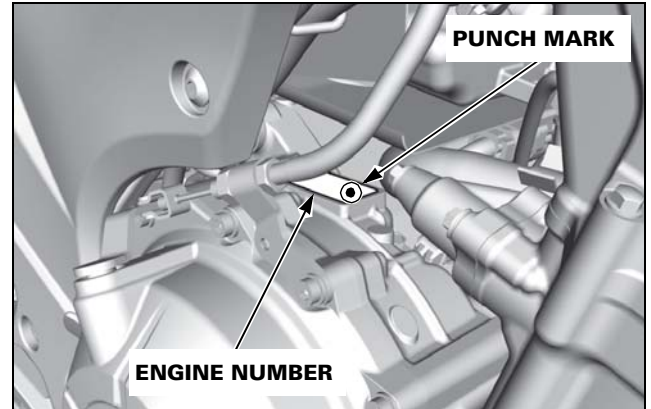

CBR650F/FA*

Place a punch mark on the frame, next to the Safety Certification Label, nearby the VIN as shown.

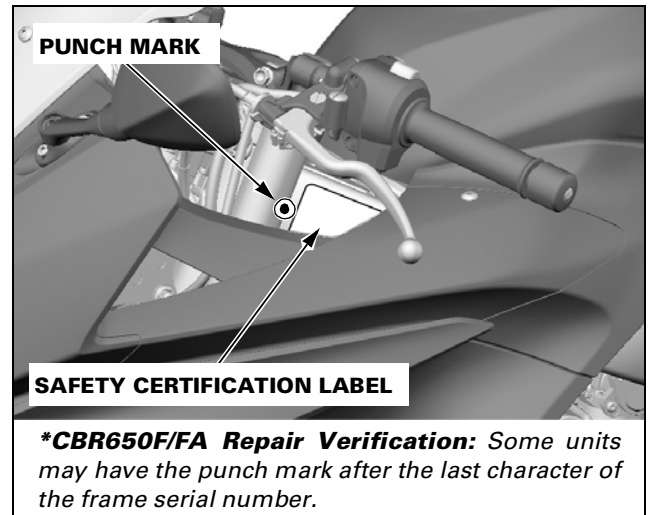

ST1300PA

Place a punch mark on the frame at the top edge of the frame serial number boss as shown.

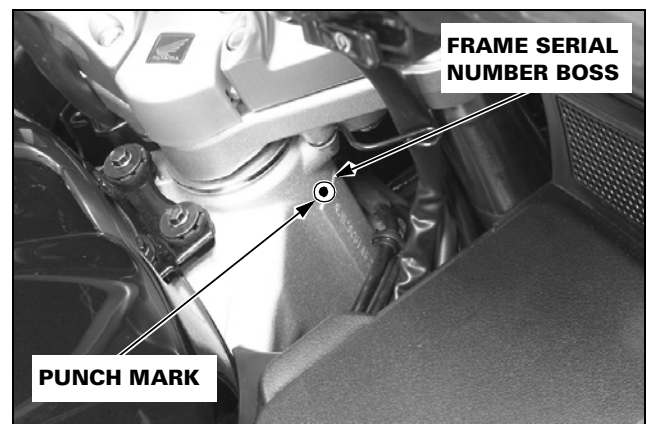

MULTI-MODEL: STARTER RELAY SWITCH #1
REVISED: DECEMBER 2015

CTX700/D, CTX700N/ND*, NC700X/XD, NC700JD (NM4)

Place a punch mark on the frame next to the color label (located under the seat) as shown.

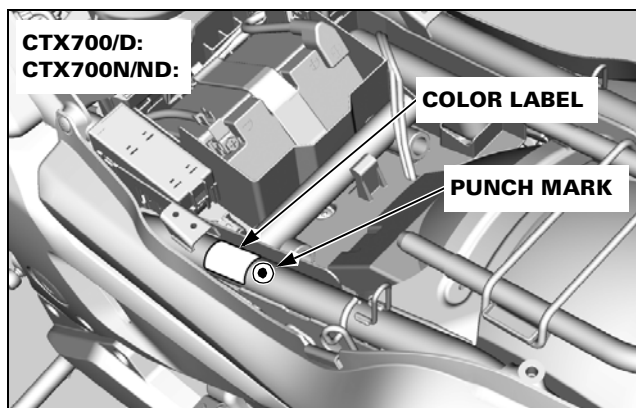

**CTX700N/ND Repair Verification: Some units may have the punch mark after the last character of the frame serial number.*

NC700X/XD:

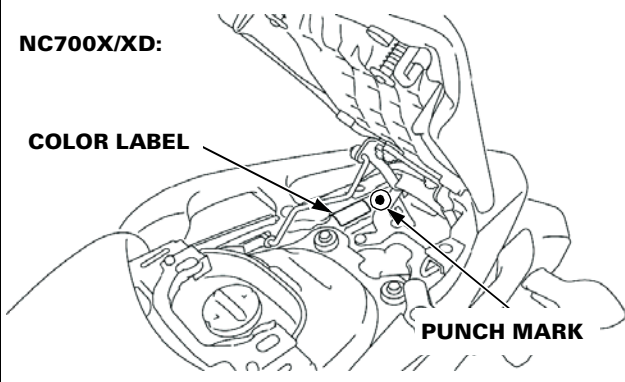

NC700JD (NM4):

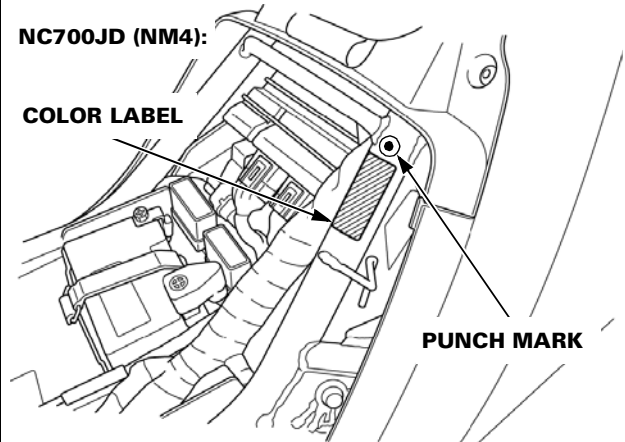

VT750C/CA, VT750C2, VT750C2B, VT750C2F

Place a punch mark after the last character of the stamped frame serial number as shown.

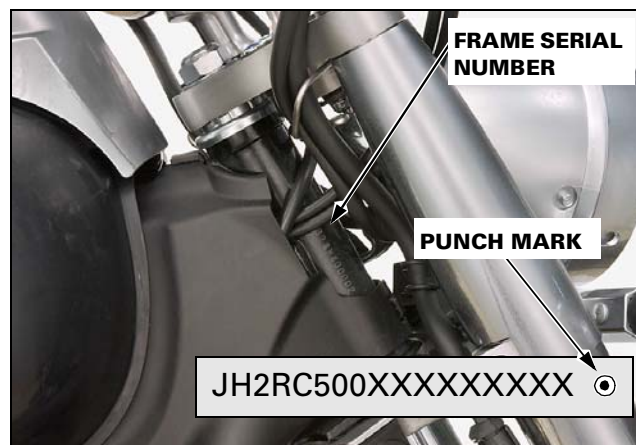

VT750 Repair Verification: Some models have the frame serial number running top-to-bottom, others have it running bottom-to-top; therefore the punch mark may appear above or below the frame serial number.

VT1300CX/CXA, VT1300CR/CRA, VT1300CT/CTA

Place a punch mark after the last character of the stamped frame serial number as shown.

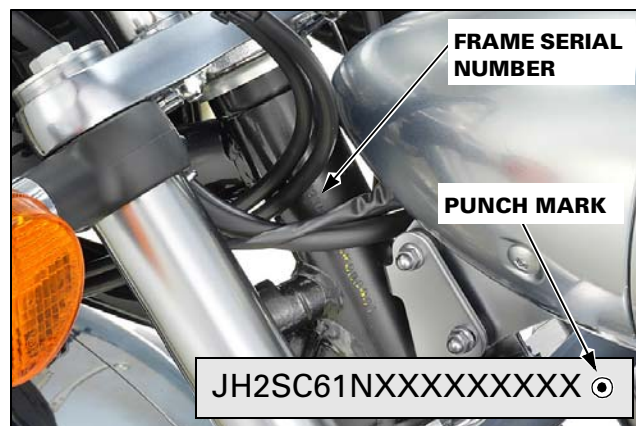

PARTS INFORMATION

REQUIRED PARTS

Initially, parts were allocated to your dealership based upon your affected inventory. Parts are now available on open order.

Kit, Start Switch

P/N 06353-MR5-306

See [CLAIM](#) and [PARTS INFORMATION](#) section of this bulletin for model application.

Contents:

Switch Assy., Starter Relay [*Black top*] (1)
Blade Fuse, Medium 30A (1)
Blade Fuse, Medium 20A (1) **Do not use.**
Blade Fuse, Medium 15A (1) **Do not use.**

Kit, Start Switch

P/N 06353-MT4-306

See [CLAIM](#) and [PARTS INFORMATION](#) section of this bulletin for model application.

Contents:

Switch Assy., Starter Relay [*Green top*] (1)
Blade Fuse, Medium 30A (1)
Blade Fuse, Medium 20A (1) **Do not use.**
Blade Fuse, Medium 15A (1) **Do not use.**

DEALER SUPPORT

Technical Questions

If you have any technical questions relating to identification/repair procedures, repair verification (punch marks), or parts information, please contact:

Motorcycle TechLine Online:

iN > Service > TechLine > TechLine Connect

Or call (800) 421-1900, option 9

Warranty Questions

If you have any warranty administration questions relating to warranty claim templates and claim filing procedures, please call:

Motorcycle Warranty, (800) 421-1900, option 7

CLAIM AND PARTS INFORMATION

Use the table below to find the Flat Rate Time (FRT), Warranty Claim Template, and replacement part number for the model at hand.

Model	FRT (Same for both procedures)	Claim Template (Inspection Only)	Claim Template (Inspect and Replace)	Replacement Part Number
CRF250L	0.3 hrs	JS9A	JS9B	06353-MT4-306
CB300F	0.4 hrs	JS9C	JS9D	06353-MR5-306
CBR300R/RA	0.4 hrs	JS9C	JS9D	06353-MR5-306
NSS300/A	0.3 hrs	JT0(Zero)A	JT0(Zero)B	06353-MR5-306
CB500F/FA	0.3 hrs	JS9E	JS9F	06353-MT4-306
CB500X/XA	0.3 hrs	JS9E	JS9F	06353-MT4-306
CBR500R/RA	0.3 hrs	JS9E	JS9F	06353-MT4-306
CBR600RR/RA	0.3 hrs	JS9G	JS9H	06353-MR5-306
CBR650F/FA	0.3 hrs	JS9J	JS9K	06353-MT4-306
CTX700/D	0.2 hrs	JS9N	JS9P	06353-MT4-306
CTX700N/ND	0.2 hrs	JS9N	JS9P	06353-MT4-306
NC700X/XD	0.3 hrs	JS9Q	JS9R	06353-MR5-306
NC700JD (NM4)	0.2 hrs	JS9S	JS9T	06353-MT4-306
VT750C/CA	0.3 hrs	JS9L	JS9M	06353-MT4-306
VT750C2	0.3 hrs	JS9L	JS9M	06353-MT4-306
VT750C2B	0.3 hrs	JS9L	JS9M	06353-MT4-306
VT750C2F	0.3 hrs	JS9L	JS9M	06353-MT4-306
ST1300PA	0.4 hrs	JS9V	JS9W	06353-MT4-306
VT1300CX/CXA	0.3 hrs	JS9X	JS9Y	06353-MT4-306
VT1300CR/CRA	0.3 hrs	JS9X	JS9Y	06353-MT4-306
VT1300CT/CTA	0.3 hrs	JS9X	JS9Y	06353-MT4-306

MULTI-MODEL: STARTER RELAY SWITCH #1
REVISED: DECEMBER 2015

TEXT OF CUSTOMER LETTER

August 2015

NHTSA Recall 15V-439

IMPORTANT SAFETY RECALL

This notice applies to your vehicle.

Dear Honda Motorcycle/Scooter Owner:

This notice is sent to you in accordance with the National Traffic and Motor Vehicle Safety Act.

What is the reason for this notice?

Honda has decided that a defect which relates to motor vehicle safety exists in certain 2013-2016 model year Honda motorcycles and scooters. During assembly of the starter magnetic switch, it is possible the sealant may have been applied incorrectly. Incorrectly applied sealant may cause an interruption of the electrical system which may cause the engine to A) not start or B) stall while riding. The increased resistance at the main fuse could cause the starter relay switch to catch on fire.

What should you do?

Call any authorized Honda motorcycle dealer and make an appointment to have your vehicle's starter relay switch inspected and, if necessary, replaced **at no cost to you**.

Once you make an appointment for your vehicle, be advised that the complete inspection and repair time may take approximately 30 minutes; however, please ask your dealer for the specific time your vehicle will need to be at the dealership.

For assistance with locating a Honda motorcycle dealer, you may call Honda Motorcycle Customer Support at 1-866-784-1870 or use the "find a dealer" option on www.powersports.honda.com

Who to contact if you experience a problem?

You may write to or call:

American Honda Motor Co., Inc.
Motorcycle Customer Support
Mail Stop 100-4C-7B
1919 Torrance Blvd.
Torrance, CA 90501-2746
(866)-784-1870

If you believe that American Honda or the dealer has failed or is unable to remedy the safety defect in your vehicle, without charge, within a reasonable period of time (60 days from the date you first contact the dealer for a repair appointment), you may submit a complaint to:

Administrator
National Highway Traffic Safety Administration
1200 New Jersey Ave., SE
Washington, DC 20590

Or call the toll-free Vehicle Safety Hotline at 1-888-327-4236 (TTY 1-800-424-9153), or go to <http://www.safercar.gov>

What to do if you feel this notice is in error.

Registration records indicate that you are the current owner of a Honda motorcycle or scooter involved in this campaign. If this is not the case, or the name/address information is not correct, please fill out and return the enclosed, postage-paid *Information Change Card*. We will then update our records.

What if you already had your vehicle repaired for this issue?

If you previously paid to have the starter magnetic switch repaired or replaced, you may be eligible for reimbursement. Refer to the attached Instructions for Reimbursement for the eligibility requirements and the reimbursement procedure.

Lessor Information:

Federal law requires that any vehicle lessor receiving this recall notice must forward a copy of this notice to the lessee within 10 days.

We apologize for any inconvenience this campaign may cause you.

Sincerely,

American Honda Motor Co., Inc.
Motorcycle Division

Campaign #JS9/JT0 - Service Bulletin: MULTI-MODEL: STARTER RELAY #1

MTB 15508 (1506)

TEXT OF CUSTOMER LETTER

Request For Reimbursement

Multiple Models: Starter Relay Switch Inspection/Replacement

Use this form only if you have previously paid for this repair. If you meet the following qualifications, American Honda Motor Co., Inc. will reimburse you for the cost of the **starter relay switch** replacement. No reimbursement will be made for other costs or repairs.

1. The vehicle must be an affected Honda motorcycle or scooter identified in the Honda Service Bulletin, *Multi-Model: Starter Relay Switch #1*.
2. The repair must have been required due to the failure that is the subject of this recall. Unrelated repairs will not be reimbursed.
- 3. The previous starter relay switch repair must have occurred before September 4, 2015.**
4. You must have a repair bill showing itemized parts and labor costs, the model, year, VIN, name, address and phone number of the repair shop, and the date of the repair. There must be verification of payment, such as a copy of a cancelled check, cash receipt, or paid invoice.
5. To qualify for reimbursement, it is not necessary that you still own the affected Honda motorcycle or scooter, but you must have been the owner when the starter relay switch was replaced. Only the owner at the time of the repair may request reimbursement. Do not request reimbursement for the expenses of any other owner.

IF YOU QUALIFY FOR REIMBURSEMENT:

Fill in the blanks; please print clearly.

Name: _____

Street Address: _____

City: _____ State: _____ Zip Code: _____

Telephone: _____ E-mail: _____

Vehicle Identification Number (VIN): _____

Total Amount Requested: _____

Mail this form together with a copy of your repair bill and verification of payment to:

**American Honda Motor Co., Inc.
Customer Support, M/S 100-4C-7B
1919 Torrance Blvd.
Torrance, CA 90501-2746**

Please allow 6–8 weeks for reimbursement processing.

This form is provided for dealer information and customer photocopies if needed.

MTB 15508 (1507)