

SUBJECT: Megawind MX Wandering Hose Boom Pin Improvement

DATE: 06/15/2015

NUMBER: SB-0167

TO: All Dealer Principals, Service Managers, and Parts Managers

PURPOSE:

Retaining bolts that secure retaining pins for the wandering hose boom may loosen / walk out and fail. Install FSO 1120239 Boom Arm Retention Fastener on all affected units.

WARRANTY COVERAGE:

1 Hour

PARTS REQUIRED:

Part No.	Qty.	Description
1120239	1	FSO - Boom Arm Retention Fastener Kit

UNITS TO SERVICE:

All MX Megawind 10yd, 13yd, and 16yd units built prior to 4/15/2015.

Refer to the chart on Page 2.

PROCEDURE:

Megawind Wandering Hose Boom retaining pin hardware may loosen and fall out. Lost retainers may cause the boom to dislodge from the sweeper. (FIGURE 1)

For all affected units - order and install FSO 1120239 Boom Arm Retention Fastener Kit. (FIGURE 2)

Install the FSO kit WH boom pins and retainers as instructed in the drawing supplied with the kit.

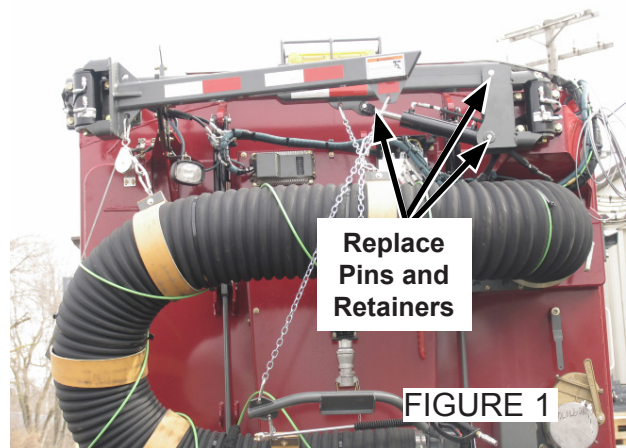

FIGURE 1

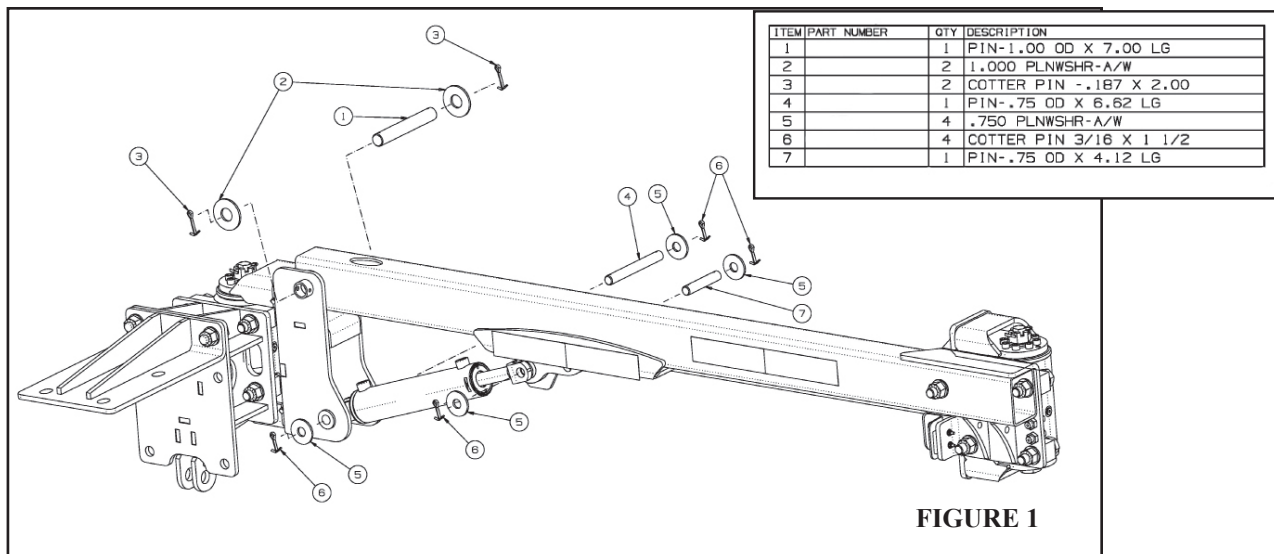

FIGURE 1

**MX and MY Serial Number
Sweepers Require FSO 1120239**

MX3001D	MX3018	MX30355
MX3002D	MX30180	MX3036
MX30030	MX30185	MX30363
MX30031	MX3019	MX3037
MX30036	MX3020	MX3038
MX3003D	MX3021	MX3039
MX3004D	MX3023	MX3040
MX30057	MX3024	MX3041
MX3005S	MX3025	MX3042
MX3006	MX30257	MX30424
MX3007	MX3026	MX30425
MX3008	MX3028	MX30426
MX3009	MX3029	MX30427
MX3010	MX30298	MX30430
MX3011	MX30299	MX30436
MX3012	MX3030	MX30437
MX3013	MX30307	MX30438
MX3014	MX30308	MX30496
MX3015	MX3031	MX30505
MX3016	MX3032	MX30572
MX30169	MX3033	MX30573
MX3017	MX3034	
MX30170	MX3035	

Warranty Coverage and Claim Submittal

The ESG dealer should submit a claim for warranty.

Use the following information when submitting a warranty claim:

CAUSAL PART: 1090452

To create the FAULT CODE, click HOPPER (07), click WELDMENTS (059), and then click FSO-BOOM ARM RETENTION FASTENER (1110).

In the FAULT FOUND drop down list, select DESIGN UPGRADE.

In the CAUSED BY drop down list, select Product Improvement.

To enter the Service procedures, perform the following:

For **INSTALLED PART # 1120239**, select HOPPER (07), select WELDMENTS (059), select FSO-BOOM ARM RETENTION FASTENER (1110), and then select INSTALL (01).

Standard Repair Time (SRT) of 1 hrs and 0 min is allowed.
