



# SAFETY RECALL BULLETIN

## NHTSA RECALL 15V289

AUTOCAR, LLC SAFETY RECALL ACX-1502

July, 2015

### Attention:

Service Managers/Parts Managers

### Subject:

Replacement of the parking brake synchronization (synchro valve) on certain Xpeditor chassis.

### Safety Recall Information:

This document provides instructions regarding the replacement of the existing synchro valve with a synchro valve which has a lower opening pressure.

OPERATORS MUST FIRMLY PRESS THE SERVICE BRAKE PEDAL PRIOR TO PRESSING THE PARKING BRAKE RELEASE BUTTON.

The replacement synchro valve will prevent unexpected engagement of the parking brake in the event the operator fails to perform this action correctly.

### Vehicles Affected:

There are 1123 affected vehicles. Refer to the VIN list beginning on Page 7.

### Service Responsibility:

Service sites must perform this recall on affected vehicles at no charge to the owner regardless of vehicle mileage, age or ownership. If a vehicle affected by this recall is taken into or is currently in your vehicle inventory, or at your center for service, you must perform this recall before the vehicle is sold or released to the owner.

### Required Parts:

- (1) S7820001K001 Synchro valve kit
- (1) A7660006-002 Synchro valve

### To Obtain Parts:

Ensure that you have authorization from the customer to perform this work, and send an e-mail to [warranty@autocartruck.com](mailto:warranty@autocartruck.com) and include the following:

- VIN(s) (or last 6 digits of VIN(s))
- 'Attention To' name
- 'Ship To' address

### Claims for Reimbursement:

Submit a claim for reimbursement in accordance with Autocar's Warranty Administration Manual.

### Claim Coding Information:

Labor Operation Code Number	Time Allowance SRT	Description
56320-0-03	2 HR	Synchro Valve Replacement

### Tools Required:

- 3/8" Drive ratchet
- 3/8" Drive 7/16" Socket
- 3/8" Drive 1/2" Socket
- 7/16" Combination wrench
- 1/2" Combination wrench
- Diagonal cutting pliers



# **SAFETY RECALL BULLETIN**

## **NHTSA RECALL 15V289**

**AUTOCAR, LLC SAFETY RECALL ACX-1502**

**July, 2015**

### **Safety Notices**



#### **WARNING**

To prevent eye injury, always wear eye protection when performing vehicle maintenance, service or inspection.



#### **WARNING**

Before working on a vehicle, set the parking brake, place the transmission in neutral and block the wheels. Failure to do so can result in unexpected vehicle movement and can cause serious personal injury or death.



#### **WARNING**

Autocar natural gas powered vehicles require specific compliance in the service, storage and refueling procedures.

If you store or dispense Compressed Natural Gas (CNG) or Liquid Natural Gas (LNG), or if you work on CNG or LNG trucks, your location must be fully compliant with applicable codes, regulations and standards, including National Fire Protection Association (NFPA) codes, Society of Automotive Engineers (SAE) standards, American National Standards Institute (ANSI), Natural Gas Vehicle (NGV) standards, the United States Code of Federal Regulations (CFR), and your state and local fire and other applicable codes (including the California Code of Regulations and the Texas Administrative Code, as applicable).

Contact your local fire department for guidance and additional compliance information. Technicians working on Autocar trucks with CNG or LNG engines must be trained in the proper repair of CNG and LNG engines and the safe storage and dispensing of CNG and LNG.

# SAFETY RECALL BULLETIN

## NHTSA RECALL 15V289

AUTOCAR, LLC SAFETY RECALL ACX-1502

July, 2015



### CAUTION

#### LOCKOUT/TAGOUT PROCEDURES

Before entering the vehicle or vehicle body, read and follow OSHA regulations concerning entry and working in "CONFINED SPACE" OSHA 1910.146 and "LOCKOUT/TAGOUT" OSHA 1910.147. Follow OSHA regulations while performing any work on the vehicle. The vehicle must be disabled by the following steps before performing any work on the vehicle:

1. Place the transmission in NEUTRAL.
2. Set the parking brake.
3. Shut the engine OFF.
4. Lock cab doors, keep the key in your pocket. Block the wheels before entering the body or performing any work on the vehicle.
5. Turn the battery disconnect switch OFF, if equipped.
6. Completely drain the air from the primary/A system and secondary/B system by opening the drain valves on the air tanks themselves or by using the drain manifold if supplied. When draining the air tanks, do not look into the area where air is draining. Dirt or sludge particles may be expelled in the air stream and can cause eye injury.
7. Place magnetic "DANGER" signs on both cab doors before entering the body or performing any work on the vehicle.
8. Take proper precautions before working under the vehicle. Use ramps approved for the weight of your vehicle, or use floor jacks and stands. Never work under a vehicle supported by jacks alone. Always use jack stands to support the vehicle.

# SAFETY RECALL BULLETIN

## NHTSA RECALL 15V289

AUTOCAR, LLC SAFETY RECALL ACX-1502

July, 2015

### REPLACEMENT OF SYNCHRO VALVE

1. Locate the synchro valve mounted opposite the HVAC case. Refer to Figure 1 or Figure 2 for LH or RH mounted applications.

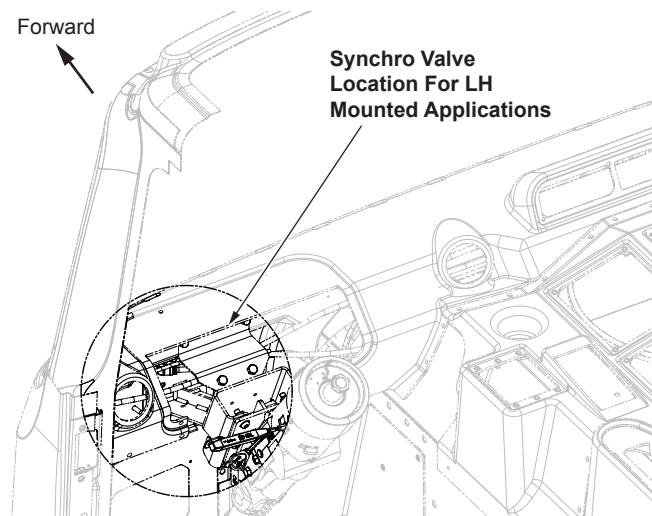

**Figure 1**

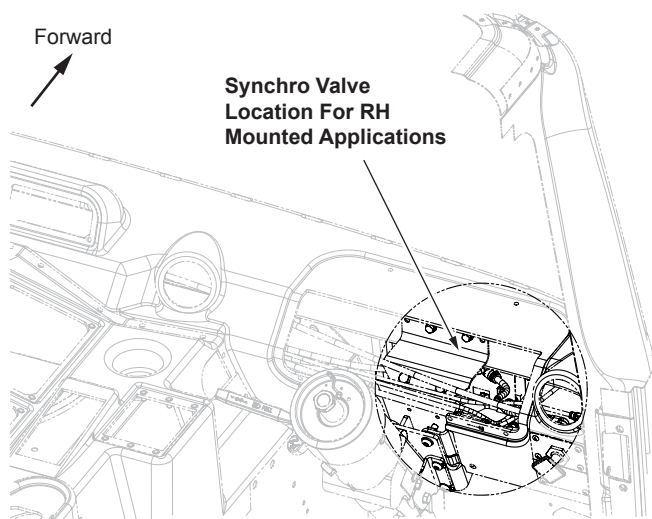

**Figure 2**

2. Disconnect all air lines to the synchro valve and the double check valve assembly.
3. Remove the valve assembly (synchro and double check valve) by removing the 2 mounting bolts and set the mounting bolts aside for reinstallation) (*see Figure 3*).
4. Separate the synchro valve from the double check valve and place the double check valve aside for reassembly.
5. Remove the air line fittings from the synchro valve and set aside for reinstallation (*see Figure 3*).
6. Discard the synchro valve.
7. Install the air line fittings into the new synchro valve (A7660006-002).
8. Assemble the synchro valve to the double check valve that was set aside in step 4.
9. Install the synchro valve and double check valve assembly by connecting the air lines that were disconnected in step 1.

**Note:** *The white exhaust line is no longer used, as the new synchro valve (A7660006-002) has an exhaust port that does not require a line. The white exhaust line can be removed and discarded or cut off as needed.*

# SAFETY RECALL BULLETIN

## NHTSA RECALL 15V289

AUTOCAR, LLC SAFETY RECALL ACX-1502

July, 2015

10. Reinstall the 2 mounting bolts that were set aside in step 3.

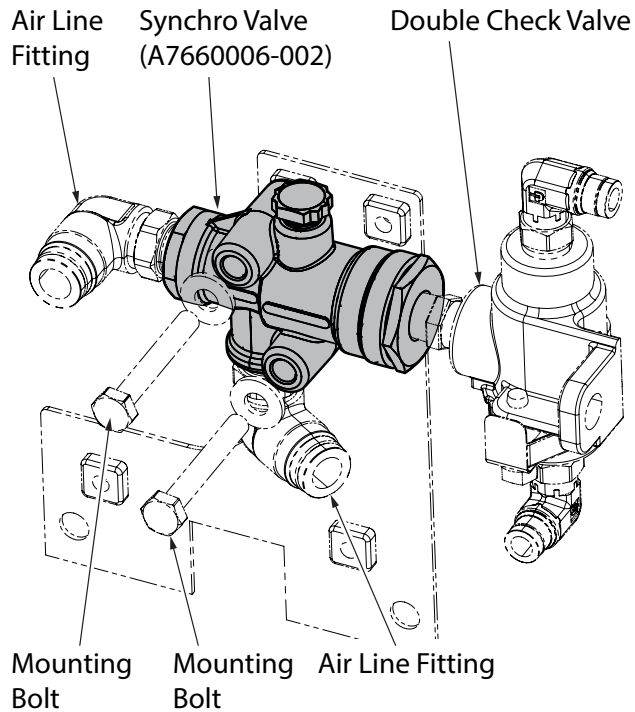

**Figure 3**

11. Perform a functional test of the new synchro valve by following steps 11.1 through 11.9.
- 11.1. Start the engine to charge the air system fully to governor cut-out.

- 11.2. Depress the yellow button to confirm that it will not remain depressed or release the parking brake (see Figure 4).

**Note:** Button should return to the out or parking brake applied position.



**Figure 4**

- 11.3. While firmly pressing the service brake pedal, depress the yellow button.

**Note:** The button should remain depressed or in the parking brake released position.

- 11.4. Drain the "A" (primary) system.

**Note:** The button should remain depressed or in the parking brake released position.



# SAFETY RECALL BULLETIN

## NHTSA RECALL 15V289

AUTOCAR, LLC SAFETY RECALL ACX-1502

July, 2015

11.5. Drain the "B" (secondary) system.

**Note:** *The button should pop out, applying the parking brake automatically at 40psi +/-3psi.*

11.6. Start the engine to charge the air system fully to governor cut-out.

11.7. While firmly pressing the service brake pedal, depress the yellow button.

**Note:** *The button should remain depressed or in the parking brake released position.*

11.8. Drain the "B" (secondary) system.

**Note:** *The button should remain depressed or in the parking brake released position.*

11.9. Drain the "A" (primary) system.

**Note:** *The button should pop out, applying the parking brake automatically at 40psi +/-3psi.*

**Note:** *If any portion of the functional test fails, please contact Autocar technical support at 888-218-3611.*

12. Repeat steps 1 through 11 for opposite side (if equipped with dual yellow button parking brakes).

13. Synchro valve replacement is complete.



# SAFETY RECALL BULLETIN

## NHTSA RECALL 15V289

AUTOCAR, LLC SAFETY RECALL ACX-1502

July, 2015

5VCACSKE6BH211758	5VCACSLE5CH213338	5VCACSLE0CH213702	5VCACS6F3CH214699
5VCACSKE8BH211759	5VCACSLE7CH213339	5VCACSLE2CH213703	5VCACSLEXDH214891
5VCACSKE4BH211760	5VCACSLE3CH213340	5VCACSLE4CH213704	5VCACSLE1DH214892
5VCACSKE6BH211761	5VCACSLE5CH213341	5VCACSLE6CH213705	5VCACSLE3DH214893
5VCACS6F2BH213011	5VCACSLE7CH213342	5VCACSLE8CH213706	5VCACSLE1DH214939
5VCACSLE7BH213016	5VCACSLEXCH213352	5VCACS8F8CH213772	5VCACSLE4DH214966
5VCACSLE9BH213017	5VCACSLE1CH213353	5VCACS8FXCH213773	5VCACSLE6DH214967
5VCACSLE0BH213018	5VCACSLE3CH213354	5VCA3SLE0CH213800	5VCACSLE8DH214968
5VCACSLE2BH213019	5VCACSLE5CH213355	5VCA3SLE2CH213801	5VCACSLEXDH214969
5VCACS8FBXCH213030	5VCACSLE7CH213356	5VCACSLE9CH213827	5VCACSLE6DH214970
5VCACS8F1BH213031	5VCACSLE9CH213357	5VCACSLE0CH213828	5VCACSLE8DH214971
5VCACSLE3BH213062	5VCACSLEXCH213383	5VCACSLE2CH213829	5VCACSLE8DH215148
5VCACSLE5BH213063	5VCACSLE1CH213384	5VCACSLE9CH213830	5VCACSLEXDH215149
5VCA3S7E8CH213103	5VCACSLE3CH213385	5VCACSLE0CH213831	5VCACSLE6DH215150
5VCA3S8F9CH213182	5VCACSLE2CH213488	5VCACSLE2CH213832	5VCACSLE8DH215151
5VCACSLE9CH213259	5VCACSLE4CH213489	5VCACSLE4CH213833	5VCACS8F8DH215281
5VCACSLE5CH213260	5VCACSLE0CH213490	5VCACSLE6CH213834	5VCACS8FXDH215282
5VCACSLE7CH213261	5VCACSLE2CH213491	5VCACSLE8CH213835	5VCACSLE2DH215372
5VCACSLE9CH213262	5VCACSLE4CH213492	5VCACSLEXCH213836	5VCACSLE4DH215373
5VCACSLE0CH213263	5VCACSLE6CH213493	5VCACSLE1CH213837	5VCACSLE8DH215375
5VCACSLE2CH213264	5VCACSLE8CH213494	5VCACSLE3CH213838	5VCA3SLE4DH215521
5VCACSLE4CH213265	5VCACSLEXCH213495	5VCACSLE6CH213980	5VCA3SLE6DH215522
5VCACSLE6CH213266	5VCACSLE1CH213496	5VCA3SLE5CH213985	5VCA3SLE8DH215523
5VCACSLE8CH213267	5VCACSLE3CH213497	5VCACS7E9CH214101	5VCACS8F5DH215531
5VCACSLEXCH213268	5VCACSLE5CH213498	5VCACSLE8CH214208	5VCACS8F7DH215532
5VCACSLE1CH213269	5VCACSLE7CH213499	5VCACSLEXCH214209	5VCACSLE1DH215590
5VCACSLE8CH213270	5VCACSLEXCH213500	5VCACSLE6CH214210	5VCACS8F1DH215932
5VCACSLEXCH213271	5VCACSLE1CH213501	5VCACSLE8CH214211	5VCA3SVF5EH216233
5VCACSLE1CH213272	5VCACSLE3CH213502	5VCACSLEXCH214212	5VCA3SVF7EH216234
5VCACSLE3CH213273	5VCA3SLE9CH213682	5VCACSLE1CH214213	5VCACSLE0EH216442
5VCACSLE5CH213274	5VCA3SLE0CH213683	5VCACSLE3CH214214	5VCACSLE2EH216443
5VCACSLE6CH213333	5VCA3SLE2CH213684	5VCACSLE5CH214215	5VCACSLE4EH216444
5VCACSLE8CH213334	5VCACSLE2CH213698	5VCACSLE7CH214216	5VCACSLE6EH216445
5VCACSLEXCH213335	5VCACSLE4CH213699	5VCACSLE9CH214217	5VCACSLE8EH216446
5VCACSLE1CH213336	5VCACSLE7CH213700	5VCACS8F5CH214376	5VCACSLEXEH216447
5VCACSLE3CH213337	5VCACSLE9CH213701	5VCACS8F7CH214377	5VCACSLE1EH216448



# SAFETY RECALL BULLETIN

## NHTSA RECALL 15V289

AUTOCAR, LLC SAFETY RECALL ACX-1502

July, 2015

5VCACSLE3EH216449	5VCACRVFXEH217385	5VCACRVF0EH217444	5VCACDUF3EH217541
5VCA3SLE0EH216666	5VCACRUF3EH217407	5VCACRVF2EH217445	5VCACDUF5EH217542
5VCACRLE2EH216807	5VCACRUF5EH217408	5VCACRVF4EH217446	5VCACDUF7EH217543
5VCACSLE6EH216834	5VCACRUF7EH217409	5VCACDLE1EH217448	5VCACDUF9EH217544
5VCACDUF8EH217017	5VCACRUF3EH217410	5VCACDVF3EH217456	5VCACDVF5EH217555
5VCACDLE2EH217037	5VCACRUF5EH217411	5VCACDVF5EH217457	5VCACRLE8EH217556
5VCACDLE4EH217038	5VCACRUF7EH217412	5VCACDVF7EH217458	5VCACRLEXEH217557
5VCACDLE6EH217039	5VCACRUF9EH217413	5VCACDVF9EH217459	5VCACRVF5EH217634
5VCACDLE2EH217040	5VCACRUF0EH217414	5VCACDVF5EH217460	5VCACRVF7EH217635
5VCACDLE4EH217041	5VCACRUF2EH217415	5VCACDVF7EH217461	5VCACDVF7EH217637
5VCACDLE6EH217042	5VCACRUF4EH217416	5VCACDVF9EH217462	5V4A4DVF8EH217638
5VCACSLE4EH217156	5VCACRUF6EH217417	5VCACDVF0EH217463	5VCACR8G9EH217639
5VCACSLE6EH217157	5VCACRUF8EH217418	5VCACDVF2EH217464	5VCACR8G5EH217640
5VCACSLE8EH217158	5VCACRVFXEH217419	5VCACDVF4EH217465	5VCACR8G7EH217641
5VCACRVF1EH217159	5VCACRUF6EH217420	5VCACDVF1EH217472	5VCACR8G9EH217642
5VCACSLE0EH217283	5VCACRUF8EH217421	5VCACDVF3EH217473	5VCACR8G0EH217643
5VCA3SLE1EH217289	5VCACRVFXEH217422	5VCACDVF6EH217483	5VCACR8G2EH217644
5VCA3SLE9EH217296	5VCACRUF1EH217423	5VCACDVF5EH217488	5VCACRVF9EH217653
5VCA3SLE0EH217297	5VCACRUF3EH217424	5VCACDVF7EH217489	5VCACRVF5EH217682
5VCACDVF1EH217312	5VCACRUF5EH217425	5VCACDVF5EH217491	5VCACRVF7EH217683
5VCACDLE9EH217326	5VCACRUF7EH217426	5VCACDVF7EH217492	5VCACRLE1EH217687
5VCACRVF9EH217328	5VCACRUF9EH217427	5VCACDVF9EH217493	5VCACRLE3EH217688
5VCACRVF0EH217329	5VCACRUF0EH217428	5VCACDVF0EH217494	5VCACRVF6EH217710
5VCACRVF7EH217330	5VCACRUF2EH217429	5VCACDVF2EH217495	5VCACRVFXEH217712
5VCACRVF9EH217331	5VCACRUF9EH217430	5VCACDVF4EH217496	5VCACRLE2EH217715
5VCACRVF0EH217332	5VCACRUF0EH217431	5VCACDVF6EH217497	5VCACDSF8EH217716
5VCACRVF2EH217333	5VCACRUF2EH217432	5VCACRVF1EH217517	5VCACDSFXEH217717
5VCACRVF4EH217334	5VCACRUF4EH217433	5VCACRVF3EH217518	5VCACDSF1EH217718
5VCACRVF9EH217376	5VCACRUF6EH217434	5VCACRVF5EH217519	5VCACDSF3EH217719
5VCACRVF0EH217377	5VCACRUF8EH217435	5VCACRVF1EH217520	5VCACDSFXEH217720
5VCACRVF2EH217378	5VCACRVFXEH217436	5VCACRVF3EH217521	5VCACDSF1EH217721
5VCACRVF4EH217379	5VCACRUF1EH217437	5VCACRVF5EH217522	5VCACDSF3EH217722
5VCACRVF0EH217380	5VCACRUF3EH217438	5VCACRVF7EH217523	5VCACSVF6EH217729
5VCACRVF2EH217381	5VCACRUF5EH217439	5VCACRVF9EH217524	5VCACSVF2EH217730
5VCACRVF4EH217382	5VCACDLE9EH217441	5VCACRVF0EH217525	5VCACSVF4EH217731
5VCACRVF6EH217383	5VCACDLE0EH217442	5VCACDUF5EH217539	5VCACSVF6EH217732
5VCACRVF8EH217384	5VCACRVF9EH217443	5VCACDUF1EH217540	5VCACSVF8EH217733



# SAFETY RECALL BULLETIN

## NHTSA RECALL 15V289

AUTOCAR, LLC SAFETY RECALL ACX-1502

July, 2015

5VCACSVFxEH217734	5VCACSLE9EH217816	5VCACRLE2FH217909	5VCACDVF0FH218002
5VCACSVF1EH217735	5VCACSLE0EH217817	5VCACRLE9FH217910	5VCACSVF8FH218009
5VCACSVF3EH217736	5VCACSLE2EH217818	5VCACRLE0FH217911	5VCACDVF7FH218014
5VCACSVF5EH217737	5VCACSLE4EH217819	5VCACRLE2FH217912	5VCACDVF9FH218015
5VCACSVF7EH217738	5VCACSLE0EH217820	5VCACRLE4FH217913	5VCACDVF0FH218016
5VCACDVF0EH217740	5VCACSLE2EH217821	5VCACRLE6FH217914	5VCACDVF2FH218017
5VCACRVF3EH217745	5VCACSLE4EH217822	5VCACRLE8FH217915	5VCACDVF4FH218018
5VCACRLE7EH217757	5VCACSLE6EH217823	5VCACRLEXFH217916	5VCACSVF0FH218019
5VCACDVF8EH217761	5VCACSLE8EH217824	5VCACRLE1FH217917	5VCACSLE4FH218020
5VCACRLE0EH217762	5VCACDLE9EH217830	5VCACRLE3FH217918	5VCACRLE7FH218022
5VCACRUG2EH217763	5VCACDLE0EH217831	5VCACRLE5FH217919	5VCACRLE5FH218035
5VCACRLEXEH217770	5VCACDLE2EH217832	5VCACRLE1FH217920	5VCACRLE7FH218036
5VCACRLE1EH217771	5VCACDLE4EH217833	5VCACRLE3FH217921	5VCACRVF4FH218050
5VCACRLE3EH217772	5VCACSVF2EH217842	5VCACRLE5FH217922	5VCACRVF6FH218051
5VCACRLE5EH217773	5VCACDVF3EH217859	5VCACRLE7FH217923	5VCACDLE3FH218067
5VCACRLE7EH217774	5VCACR8G6FH217860	5VCACRLE9FH217924	5VCACDLE5FH218068
5VCA3RVF5EH217777	5VCA3DLE7FH217861	5VCACDVF1FH217926	5VCACDLE7FH218069
5VCACSVF5EH217785	5VCACDVF1FH217862	5VCACDVF3FH217927	5VCACDLE3FH218070
5VCACSVF7EH217786	5VCACDLE0FH217863	5VCACD8G8FH217930	5VCACDLE5FH218071
5VCACDVF4EH217790	5VCACDLE2FH217864	5VCACDVF5FH217931	5VCACDLE7FH218072
5VCACDVF6EH217791	5VCACDLE4FH217865	5VCACSVF1FH217932	5VCACDLE9FH218073
5VCACDVF8EH217792	5VCACDLE6FH217866	5VCACRLEXFH217933	5VCACDLE0FH218074
5VCACDVFxEH217793	5VCACSVE6FH217867	5VCACRLE1FH217934	5VCACDLE2FH218075
5VCACDVF1EH217794	5VCACSVE8FH217868	5VCACR8G4FH217968	5VCACDLE4FH218076
5VCA3RUF9EH217802	5VCACRLE5FH217872	5VCACR8G6FH217969	5VCACDLE6FH218077
5VCA3RUF0EH217803	5VCACRLE7FH217873	5VCACR8G2FH217970	5VCACDLE8FH218078
5VCA3RUF2EH217804	5VCACDVF1EH217875	5VCACR8G4FH217971	5VCACDLEXFH218079
5VCACD8G7EH217805	5VCACRLE3FH217899	5VCACR8G6FH217972	5VCACDLE6FH218080
5VCACRVFxEH217807	5VCACRLE6FH217900	5VCA3RLE3FH217983	5VCACDLE8FH218081
5VCACSLEXEH217808	5VCACRLE8FH217901	5VCACDLE0FH217989	5VCACRLE9FH218099
5VCACSLE1EH217809	5VCACRLEXFH217902	5VCACDVFXFH217990	5VCACRLE1FH218100
5VCACSLE8EH217810	5VCACRLE1FH217903	5VCACDVF1FH217991	5VCACRLE3FH218101
5VCACSLEXEH217811	5VCACRLE3FH217904	5VCACRLE3FH217997	5VCACRLE5FH218102
5VCACSLE1EH217812	5VCACRLE5FH217905	5VCACRLE5FH217998	5VCACRLE7FH218103
5VCACSLE3EH217813	5VCACRLE7FH217906	5VCACRLE7FH217999	5VCACRLE9FH218104
5VCACSLE5EH217814	5VCACRLE9FH217907	5VCACRLE8FH218000	5VCACRUF1FH218105
5VCACSLE7EH217815	5VCACRLE0FH217908	5VCACDVF9FH218001	5VCACRUF3FH218106



# SAFETY RECALL BULLETIN

## NHTSA RECALL 15V289

AUTOCAR, LLC SAFETY RECALL ACX-1502

July, 2015

5VCACRUF5FH218107	5VCACRVF4FH218257	5VCA3DLE4FH218398	5VCACRLEXFH218466
5VCACRUF7FH218108	5VCACRVF6FH218258	5VCA3DLE6FH218399	5VCACRLE1FH218467
5VCACRUF9FH218109	5VCACDVF4FH218259	5VCA3DLE9FH218400	5VCACRLE3FH218468
5VCACDVF3FH218110	5VCACRVF4FH218260	5VCACDLE0FH218401	5VCACRLE5FH218469
5VCACRVF1FH218149	5VCA3RLE7FH218263	5VCACDLE2FH218402	5VCACRLE1FH218470
5VCACSLE1FH218153	5VCACRLE9FH218264	5VCACRLE3FH218406	5VCACRLE3FH218471
5VCACSLE5FH218172	5VCACRLE0FH218265	5VCACRUF8FH218408	5VCACRLE5FH218472
5VCACDVF5FH218173	5VCACRLE2FH218266	5VCACRUFXFH218409	5VCACRLE7FH218473
5VCACRLE8FH218174	5VCACRLE4FH218267	5VCACRLE5FH218410	5VCACD8G3FH218497
5VCACRLEXFH218175	5VCACRLE6FH218268	5VCACRLE7FH218411	5VCACD8G5FH218498
5VCACRLE1FH218176	5VCACRLE8FH218269	5VCA3SVF2FH218412	5VCACD8G7FH218499
5VCACRLE3FH218177	5VCA3SLE5FH218270	5VCA3SVF4FH218413	5VCACRUF4FH218504
5VCACRLE5FH218178	5VCA3SLE7FH218271	5VCA3RLE2FH218414	5VCACRUF6FH218505
5VCACRLE7FH218179	5VCA3SLE9FH218272	5VCACSLE5FH218415	5VCACRUF8FH218506
5VCACRLE3FH218180	5VCACRLEXFH218273	5VCACRLE2FH218428	5VCACRUFXFH218507
5VCACRLE5FH218181	5VCACRLE1FH218274	5VCACRLE4FH218429	5VCACRUF1FH218508
5V4A4DVF3FH218231	5VCACR8G9FH218288	5VCACRLE0FH218430	5VCACRUF3FH218509
5VCACDSF0FH218232	5VCACR8G0FH218289	5VCACRLE2FH218431	5VCACRUFXFH218510
5VCACDLE5FH218233	5VCACR8G7FH218290	5VCACRLE4FH218432	5VCACRUF1FH218511
5VCACDLE7FH218234	5VCACR8G9FH218291	5VCACRLE8FH218434	5VCACRUF3FH218512
5VCACDLE9FH218235	5VCACR8G0FH218292	5VCACRLEXFH218435	5VCACRUF5FH218513
5VCACDLE2FH218237	5VCACR8G2FH218293	5VCACRLE1FH218436	5VCACRUF7FH218514
5VCACDLE4FH218238	5VCACRUF8FH218294	5VCACRLE3FH218437	5VCACRUF9FH218515
5VCACDLE6FH218239	5VCACRUFXFH218295	5VCACRLE5FH218438	5VCACRUF0FH218516
5VCACDLE2FH218240	5VCACDVFXFH218315	5VCACRLE7FH218439	5VCACRUF2FH218517
5VCACDLE4FH218241	5VCACDVF1FH218316	5VCACRLE3FH218440	5VCACRUF4FH218518
5VCACDLE6FH218242	5VCACRUF5FH218317	5VCACRLE5FH218441	5VCACRUF6FH218519
5VCACRVF4FH218243	5VCACDUH8FH218333	5VCACRLE7FH218442	5VCACRUF2FH218520
5VCACRVF6FH218244	5VCA3RVF4FH218341	5VCACDLE5FH218443	5VCACRUF4FH218521
5VCACRVF8FH218245	5VCACSLE8FH218344	5VCACRLE0FH218444	5VCACRUF6FH218522
5VCACRVXFH218246	5VCACDLE5FH218345	5VCACRLE2FH218445	5VCACRUF8FH218523
5VCACRVF1FH218247	5VCACDLE7FH218346	5VCACR8GXFH218459	5VCACRUFXFH218524
5VCACRLE2FH218249	5VCACDLE9FH218347	5VCACRVF3FH218461	5VCACRUF1FH218525
5VCACRLE9FH218250	5VCACDLE0FH218348	5VCACRVF5FH218462	5VCACRUF3FH218526
5VCACRVF9FH218254	5VCACRUFXFH218393	5VCACRVF7FH218463	5VCACRUF5FH218527
5VCACRVF0FH218255	5VCA3DLE0FH218396	5VCACRLE6FH218464	5VCACRUF7FH218528
5VCACRVF2FH218256	5VCA3DLE2FH218397	5VCACRLE8FH218465	5VCACRUF9FH218529



# SAFETY RECALL BULLETIN

## NHTSA RECALL 15V289

AUTOCAR, LLC SAFETY RECALL ACX-1502

July, 2015

5VCACRUF5FH218530	5VCACRVF2FH218600	5VCACRLE5FH218763	5VCACRLE0FH218864
5VCACRUF7FH218531	5VCACRLE1FH218601	5VCACRLE7FH218764	5VCACRVF9FH218867
5VCACRUF9FH218532	5VCACRLE3FH218602	5VCACRLE9FH218765	5VCACRVF0FH218868
5VCACRUF0FH218533	5VCACRLE5FH218603	5VCACRLE0FH218766	5VCACRVF2FH218869
5VCACDVF0FH218534	5VCACRLE7FH218604	5VCACRLE2FH218767	5VCACRVF9FH218870
5VCACDVF2FH218535	5VCACRLE9FH218605	5VCACRLE4FH218768	5VCACDVF7FH218871
5VCACDVF4FH218536	5VCACRVF5FH218607	5VCACRLE6FH218769	5VCACDVF9FH218872
5VCACDVF6FH218537	5VCACRVF7FH218608	5VCACRLE2FH218770	5VCACDVF0FH218873
5VCACRUFXFH218538	5VCACRVF9FH218609	5VCACRLE4FH218771	5VCACDVF2FH218874
5VCACRLE6FH218545	5VCACSLE7FH218626	5VCACRLE6FH218772	5VCACDVF4FH218875
5VCACRLE8FH218546	5VCACRLE8FH218644	5VCACRLE8FH218773	5VCACDVF8FH218877
5VCACRLEXFH218547	5VCACRLEXFH218645	5VCACRLEXFH218774	5VCACRLE0FH218878
5VCACRLE1FH218548	5VCACRLE1FH218646	5VCACRLE1FH218775	5VCACRLE2FH218879
5VCACRLE3FH218549	5VCACRLE3FH218647	5VCACRLE3FH218776	5VCACRLE9FH218880
5VCA3RLEXFH218550	5VCACRLE5FH218648	5VCACRLE5FH218777	5VCACRLE0FH218881
5VCA3RLE1FH218551	5VCACRLE3FH218664	5VCACRLE7FH218778	5VCACRLE2FH218882
5VCA3RVFXFH218554	5VCACRLE5FH218665	5VCACRLE9FH218779	5VCACRLE4FH218883
5VCACR8G6FH218555	5VCACRLE7FH218666	5VCACRLE5FH218780	5VCACRLE6FH218884
5VCACDVFXFH218556	5VCACRLE9FH218667	5VCACRLE7FH218781	5VCACRLE8FH218885
5VCACDVF1FH218557	5VCACRLE0FH218668	5VCACRLE9FH218782	5VCACRLEXFH218886
5VCACDVF3FH218558	5VCACDVF1FH218686	5VCACRLE0FH218783	5VCACRLE1FH218887
5VCACDVF5FH218559	5VCACRVF0FH218689	5VCACDVF9FH218788	5VCACRLE3FH218888
5VCACSLE9FH218563	5VCACRVF7FH218690	5VCACDVF0FH218789	5VCACRLE5FH218889
5VCACSLE0FH218564	5VCACRVF9FH218691	5VCACDVF7FH218790	5VCACRUF5FH218916
5VCACDVF0FH218565	5VCACRVF0FH218692	5VCACDVF9FH218791	5VCACDLE2FH218917
5VCACDVF8FH218569	5VCACSLE2FH218694	5VCACDVF6FH218828	5VCACDLE4FH218918
5VCACDVF3FH218575	5VCACSLE4FH218695	5VCA3SVF0FH218831	5VCACDLE6FH218919
5VCACDVF5FH218576	5VCACSLE6FH218696	5VCA3DVE1FH218839	5VCACDLE2FH218920
5VCACDVF7FH218577	5VCACSLE8FH218697	5VCACDLEXFH218843	5VCA3RVF0FH218921
5VCACDVF9FH218578	5VCACRLE6FH218755	5VCACDVFXFH218850	5VCA3RVF2FH218922
5VCACDVF0FH218579	5VCACRLE8FH218756	5VCACDVF1FH218851	5VCACD8F6FH218923
5VCACDVF7FH218580	5VCACRLEXFH218757	5VCACDSFXFH218853	5VCACDVF2FH218924
5VCACDVF9FH218581	5VCACRLE1FH218758	5VCACRLE7FH218859	5VCACRVF8FH218925
5VCACDVF0FH218582	5VCACRLE3FH218759	5VCACRLE3FH218860	5VCACRLE7FH218926
5VCACSUF5FH218583	5VCACRLEXFH218760	5VCACRLE5FH218861	5VCACRLE9FH218927
5VCACRLE5FH218584	5VCACRLE1FH218761	5VCACRLE7FH218862	5VCACRLE0FH218928
5VCACR8G4FH218585	5VCACRLE3FH218762	5VCACRLE9FH218863	5VCACRLE2FH218929



# SAFETY RECALL BULLETIN

## NHTSA RECALL 15V289

AUTOCAR, LLC SAFETY RECALL ACX-1502

July, 2015

5VCACRLE9FH218930	5VCACRLE1FH219022	5VCA3DVF7FH219065	5VCACDLE2FH219226
5VCACRLE0FH218931	5VCACDLEXFH219023	5VCACRLE1FH219070	5VCACDLE4FH219227
5VCACRLE2FH218932	5VCACSLE6FH219024	5VCACSVF0FH219073	5VCACDLE6FH219228
5VCACRLE4FH218933	5VCACDLE3FH219025	5VCACDLE5FH219074	5VCACRLE6FH219257
5VCACRSF0FH218938	5VCACDLE9FH219031	5VCACDLE7FH219075	5VCACRLE8FH219258
5VCACDLE0FH218947	5VCACDLE0FH219032	5VCACDLE9FH219076	5VCACDVF9FH219259
5VCACDLE2FH218948	5VCACDVF7FH219034	5VCACDLE0FH219077	5VCACDLEXFH219281
5VCACDLE4FH218949	5VCACDVF9FH219035	5VCACDLE2FH219078	5VCACDLE1FH219282
5VCACDLE0FH218950	5VCACDVF0FH219036	5VCACDLE4FH219079	5VCACDLE3FH219283
5VCACDLE2FH218951	5VCACDVF2FH219037	5VCACDLE0FH219080	5VCACDLE5FH219284
5VCACDLE4FH218952	5VCACDVF4FH219038	5VCACSLE7FH219145	5VCACDVFXFH219285
5VCACRLEXFH218953	5VCACDVF6FH219039	5VCA3SLE2FH219148	5VCACDVF8FH219303
5VCA3SVF5FH218954	5VCACDVF2FH219040	5VCACDVF2FH219149	5VCACDVFXFH219304
5VCACDVF4FH218956	5VCACDVF4FH219041	5VCACDVF9FH219150	5VCACDVF1FH219305
5VCACDVF6FH218957	5VCACDVF6FH219042	5VCACRVF3FH219156	5VCACDLE2FH219310
5VCACDVF8FH218958	5VCACDVF8FH219043	5VCACRVF5FH219157	5VCACDLE4FH219311
5VCACDVFXFH218959	5VCACDLE7FH219044	5VCACRVF7FH219158	5VCACDLE6FH219312
5VCACRVFXFH218960	5VCACDLE9FH219045	5VCACRVF9FH219159	5VCACDLE8FH219313
5VCACRVF1FH218961	5VCACDLE0FH219046	5VCACRVF5FH219160	5VCACDLEXFH219314
5VCACRVF3FH218962	5VCACDLE2FH219047	5VCACRVF7FH219161	5VCACDLE1FH219315
5VCACRVF5FH218963	5VCACDLE4FH219048	5VCACRVF9FH219162	5VCACDLE3FH219316
5VCACRVF7FH218964	5VCACDLE6FH219049	5VCACD8G9FH219167	5VCACDLE5FH219317
5VCACRVF9FH218965	5VCACDLE2FH219050	5VCACDSF0FH219168	5VCACDLE7FH219318
5VCACRVF0FH218966	5VCACDLE4FH219051	5VCACDSF2FH219169	5VCACDLE9FH219319
5VCACRVF2FH218967	5VCACR8G7FH219052	5VCACDSF2FH219172	5VCACDLE5FH219320
5VCACRVF4FH218968	5VCACR8G9FH219053	5VCACDSF4FH219173	5VCACDLE7FH219321
5VCACRVF6FH218969	5VCACR8G0FH219054	5VCACDSF6FH219174	5VCACDLE9FH219322
5VCACRVF2FH218970	5VCACR8G2FH219055	5VCACDSF8FH219175	5VCACDLE0FH219323
5VCACRVF4FH218971	5VCACR8G4FH219056	5VCACRUF7FH219176	5VCACDLE2FH219324
5VCACRVF6FH218972	5VCACR8G6FH219057	5VCACDLE3FH219218	5VCACDLE4FH219325
5VCACRVF8FH218973	5VCACR8G8FH219058	5VCACDLE5FH219219	5VCACDLE6FH219326
5VCACRVFXFH218974	5VCACR8GXFH219059	5VCACDLE1FH219220	5VCACDLE8FH219327
5VCACRVF1FH218975	5VCACR8G6FH219060	5VCACDLE3FH219221	5VCACDVF7FH219342
5VCACRVF3FH218976	5VCACRVF3FH219061	5VCACDLE5FH219222	5VCACDVF2FH219345
5VCACRVF5FH218977	5VCACDVF1FH219062	5VCACDLE7FH219223	5VCACDVF4FH219346
5VCACRLE8FH219020	5VCACDVF3FH219063	5VCACDLE9FH219224	5VCACR8G4FH219347
5VCACRLEXFH219021	5VCACDVF5FH219064	5VCACDLE0FH219225	5VCACR8G6FH219348



# SAFETY RECALL BULLETIN

## NHTSA RECALL 15V289

AUTOCAR, LLC SAFETY RECALL ACX-1502

July, 2015

5VCACR8G8FH219349	5VCACRVF0FH219440	5VCACSLE7FH219534	5VCACDVF0FH219800
5VCACR8G4FH219350	5VCACRVF2FH219441	5VCACSLE9FH219535	5VCACDVF2FH219801
5VCACR8G6FH219351	5VCACRVF4FH219442	5VCACSLE0FH219536	5VCACDVF4FH219802
5VCACR8G8FH219352	5VCACRVF6FH219443	5VCACDUF6FH219544	5VCACDVF6FH219803
5VCACR8GXFH219353	5VCACRVF8FH219444	5VCACDVF3FH219550	5VCACDLE4FH219809
5VCACR8G1FH219354	5VCA3RLE4FH219452	5VCACD8G7FH219586	5VCACDLE0FH219810
5VCACR8G3FH219355	5VCACDVF9FH219455	5VCACD8G9FH219587	5VCACDLE2FH219811
5VCACR8G5FH219356	5VCACDVF0FH219456	5VCACDVF6FH219588	5VCACDLE4FH219812
5VCACR8G7FH219357	5VCACDVF2FH219457	5VCACDVF8FH219589	5VCACDLE6FH219813
5VCACR8G9FH219358	5VCACDVF4FH219458	5VCACDVF3FH219595	5VCACDVF1FH219823
5VCACR8G0FH219359	5VCACRVFXFH219459	5VCACDVF5FH219596	5VCACDVF3FH219824
5VCACR8G7FH219360	5VCACRVF6FH219460	5VCACDVF5FH219646	5VCACRVF9FH219825
5VCACR8G9FH219361	5VCACRVF8FH219461	5VCACRLEXFH219648	5VCACRVF0FH219826
5VCACR8G0FH219362	5VCACRVFXFH219462	5VCACRLE1FH219649	5VCACRVF2FH219827
5VCACR8G2FH219363	5VCACRVF1FH219463	5VCACRLE8FH219650	5VCACRVF4FH219828
5VCACR8G4FH219364	5VCACR8G8FH219464	5VCACRLEXFH219651	5VCACRVF6FH219829
5VCACR8G6FH219365	5VCACR8GXFH219465	5VCACRVF4FH219652	5VCACRLEXFH219830
5VCACR8G8FH219366	5VCACRVF9FH219467	5VCACRLE3FH219653	5VCACRLE1FH219831
5VCACR8GXFH219367	5VCACDVF1FH219479	5VCACDVF0FH219750	5VCACRLE3FH219832
5VCACR8G1FH219368	5VCACDLE6FH219486	5VCACDVF2FH219751	5VCACRLE5FH219833
5VCACR8G3FH219369	5VCACDLE8FH219487	5VCACDVF4FH219752	5VCACRUF1FH219836
5VCACR8GXFH219370	5VCACDLEXFH219488	5VCACDLE7FH219769	5VCACRUF3FH219837
5VCACR8G1FH219371	5VCACRLE6FH219503	5VCACDLE3FH219770	5VCACRUF5FH219838
5VCACR8G3FH219372	5VCACDLE5FH219513	5VCACRLE9FH219771	5VCACRUF7FH219839
5VCACR8G5FH219373	5VCACDLE7FH219514	5VCACRLE0FH219772	5VCACRUF3FH219840
5VCACR8G7FH219374	5VCACRVF7FH219516	5VCACRLE2FH219773	5VCACRUF5FH219841
5VCACR8G9FH219375	5VCACDVF5FH219517	5VCACRLE4FH219774	5VCACRUF7FH219842
5VCACDLEXFH219376	5VCACDVF7FH219518	5VCACRLE6FH219775	5VCACRLE8FH219843
5VCACDLE1FH219377	5VCACRLEXFH219519	5VCACRLE8FH219776	5VCACRLEXFH219844
5VCACRLE9FH219432	5VCACRLE6FH219520	5VCACRLEXFH219777	5VCACRLE1FH219845
5VCACRLE0FH219433	5VCACRLE8FH219521	5VCACRLE1FH219778	5VCACRLE3FH219846
5VCACRLE2FH219434	5VCACRUF8FH219526	5VCACRLE3FH219779	5VCACRLE5FH219847
5VCACRVF7FH219435	5VCACRUFXFH219527	5VCACRLEXFH219780	5VCACRLE7FH219848
5VCACRVF9FH219436	5VCACRUF1FH219528	5VCACDVF2FH219796	5VCACRLE9FH219849
5VCACRVF0FH219437	5VCACDVFXFH219531	5VCACDVF4FH219797	5VCACRVF6FH219880
5VCACRVF2FH219438	5VCACSLE3FH219532	5VCACDVF6FH219798	5VCACRUF6FH219881
5VCACRVF4FH219439	5VCACSLE5FH219533	5VCACDVF8FH219799	5VCACRUF8FH219882



# SAFETY RECALL BULLETIN

## NHTSA RECALL 15V289

AUTOCAR, LLC SAFETY RECALL ACX-1502

July, 2015

5VCACSLE6FH219895	5VCACSLEXFH220001	5VCACRVF8GH220210
5VCACRUF8FH219896	5VCACRLE4FH220004	5VCACRUF3GH220231
5VCACRUFXFH219897	5VCACRLE6FH220005	5VCACRUF5GH220232
5VCACRUF1FH219898	5VCACRLE8FH220006	5VCACRUF7GH220233
5VCACRUF3FH219899	5VCACRLEXFH220007	5VCACRLE8GH220315
5VCACRLE7FH219901	5VCACRLEXFH220038	5VCACRLEXGH220316
5VCACRLE0FH219903	5VCACRVF0GH220041	5VCACRLE1GH220317
5VCACRVF5FH219904	5VCACDUF8GH220048	5VCACRLE3GH220318
5VCACRVF7FH219905	5VCACDUFXGH220049	5VCACRLE5GH220319
5VCACRVF9FH219906	5VCACDUF6GH220050	5VCACRLE1GH220320
5VCACRVF0FH219907	5VCACDLEXGH220061	5VCACRLE3GH220321
5VCACRVF2FH219908	5VCACDLE1GH220062	5VCACRLE5GH220322
5VCACRVF4FH219909	5VCACDLE3GH220063	5VCACRLE7GH220323
5VCACRVF0FH219910	5VCA3DVF0GH220088	5VCACSLE6GH220370
5VCACRVF2FH219911	5VCA3DVF2GH220089	5VCACSLE8GH220371
5VCACRVF4FH219912	5VCACDVF9GH220090	5VCACDLE4GH220377
5VCACRVF6FH219913	5VCACDVF0GH220091	5VCACDVF6GH220404
5VCA3RVF5FH219921	5VCACRUF8GH220094	
5VCACRLE4FH219922	5VCACRUFXGH220095	
5VCACRLE6FH219923	5VCACSLE1GH220129	
5VCACRLE8FH219924	5VCACSLE8GH220130	
5VCACRLEXFH219925	5VCACSLEXGH220131	
5VCACRLE1FH219926	5VCACSLE1GH220132	
5VCACRLE3FH219927	5VCACSLE3GH220133	
5VCACRLE5FH219928	5VCACDLE5GH220159	
5VCACDLE3FH219929	5VCACDLE1GH220160	
5VCACDLEXFH219930	5VCACDLE3GH220161	
5VCACDLE1FH219931	5VCACR8G6GH220162	
5VCACDLE3FH219932	5VCACDVF2GH220173	
5VCACDLE5FH219933	5VCACDSFXGH220183	
5VCACDLE7FH219934	5VCACDSF1GH220184	
5VCACDLE9FH219935	5VCACDSF3GH220185	
5VCA3DLE0FH219936	5VCACDSF5GH220186	
5VCA3DLE2FH219937	5VCACDSF7GH220187	
5VCACRVF5FH219997	5VCA3RVF0GH220203	
5VCACSLE7FH219999	5VCACRVFXGH220208	
5VCACSLE8FH220000	5VCACRVF1GH220209	