

Safety Recall

Code: 20V5



Subject	Fuel Delivery Unit
Special Repair Notes	quattro vehicles (Criteria 04) REPAIR AVAILABLE Front-wheel drive vehicles (Criteria 03) REPAIR NOT YET AVAILABLE
Release Date	May 7, 2015
Affected Vehicles	U.S.A. & CANADA: 2015 MY Audi A3 with Gasoline Engine <i>Check Campaigns/Actions screen in Elsa on the day of repair to verify that a VIN qualifies for repair under this action. Elsa is the <u>only</u> valid campaign inquiry & verification source.</i> <ul style="list-style-type: none">ü Campaign status must show "open."ü If Elsa shows other open action(s), inform your customer so that the work can also be completed at the same time the vehicle is in the workshop for this campaign.
Problem Description	On some vehicles, contamination due to improper nickel plating of certain subcomponents within the fuel pump may cause excessive pump friction, potentially resulting in an inoperative fuel pump. If the fuel pump becomes inoperative due to this condition, it may result in a no-start condition or a stall while driving without warning, and without the ability to restart the vehicle. An engine stall without warning while driving can increase the risk of a crash.
Corrective Action	Inspect and, if necessary replace the fuel delivery unit.
Parts Information	Parts will be allocated prior to campaign visibility in Elsa. If allocated parts have been used and your dealership is at the weekly Upper Order Limit, submit requests for additional parts via email to upperorderlimits@vw.com .
Code Visibility – quattro (Criteria 04)	On or about May 7, 2015 affected Criteria 04 vehicles will show REPAIR AVAILABLE status in the VIN Lookup tool at www.audiusa.com and on the NHTSA VIN lookup tool at www.safercar.gov .
Code Visibility – Front-wheel Drive (Criteria 03)	On or about May 7, 2015 affected Criteria 03 vehicles will show REPAIR NOT YET AVAILABLE status in the VIN Lookup tool at www.audiusa.com and on the NHTSA VIN lookup tool at www.safercar.gov .
Elsa & OMD Web/AIM Visibility	On or about May 7, 2015, all affected vehicles will be listed on the Inventory Vehicle Open Campaign Action report under My Dealership Reports (found on www.accessaudi.com & OMD Web/AIM). A list will not be posted for dealers who do not have any affected vehicles. On or about May 7, 2015, this campaign code will show open on all affected vehicles in Elsa.
Owner Notification	Owner notification will take place in June 2015. Owner letter examples are included in this circular for your reference.
Additional Information	Please alert everyone in your dealership about this action, including Sales, Service, Parts and Accounting personnel. Contact Warranty if you have any questions. IMPORTANT REMINDER ON VEHICLES AFFECTED BY SAFETY & COMPLIANCE RECALLS <u>New Vehicles in Dealer Inventory:</u> It is a violation of Federal law for a dealer to deliver a new motor vehicle or any new or used item of motor vehicle equipment (including a tire) covered by this notification under a sale or lease until the defect or noncompliance is remedied. By law, dealers must correct, prior to delivery for sale or lease, any vehicle that fails to comply with an applicable Federal Motor Vehicle Safety Standard or that contains a defect relating to motor vehicle safety. <u>Pre-Owned Vehicles in Dealer Inventory:</u> Dealers should not deliver any pre-owned vehicles in their inventory which are involved in a safety or compliance recall until the defect has been remedied.

Claim Entry Instructions

After campaign has been completed, enter claim as soon as possible to help prevent work from being duplicated elsewhere. Attach the Elsa screen print showing action open on the day of repair to the repair order.

If customer refused campaign work:

- ü U.S. dealers: Submit the request through Audi Warranty Online under the Campaigns/Update option.
- ü Canada dealers: Fax repair order to Warranty at (905) 428-4811.

Service Number	20V5									
Damage Code	0099									
Parts Vendor Code	002									
Claim Type	Sold vehicle: 7 10 Unsold vehicle: 7 90									
Causal Indicator	Mark fuel delivery unit as causal part									
Vehicle Wash/Loaner	Do not claim wash/loaner under this action									
Criteria I.D.	03 (FWD)									
	REPAIR NOT AVAILABLE AT THIS TIME									
Criteria I.D.	04 (quattro)									
	<p>Check fuel delivery unit part number. Updated part present, no further work required Labor operation: 0183 00 99 30 T.U.</p> <p>-OR-</p> <p>Check fuel delivery unit part number; Updated part not present. Replace fuel delivery unit. Labor operation: 2066 19 00 110 T.U.</p> <table border="1" style="width: 100%; border-collapse: collapse;"> <thead> <tr> <th style="text-align: left;">Quantity</th> <th style="text-align: left;">Part Number</th> <th style="text-align: left;">Description</th> </tr> </thead> <tbody> <tr> <td>1</td> <td>5Q0919087R*</td> <td>Fuel Delivery Unit</td> </tr> <tr> <td>1</td> <td>1J0919133B</td> <td>Gasket Seal</td> </tr> </tbody> </table> <p>* Include production date from the replaced fuel sending unit in the comments of the claim.</p>	Quantity	Part Number	Description	1	5Q0919087R*	Fuel Delivery Unit	1	1J0919133B	Gasket Seal
Quantity	Part Number	Description								
1	5Q0919087R*	Fuel Delivery Unit								
1	1J0919133B	Gasket Seal								

Customer Letter Example (USA)

This notice applies to your vehicle: <VIN>

NHTSA: <INSERT NUMBER>

**Subject: Safety Recall 20V5 – Fuel Delivery Unit
2015 Model Year Audi A3 with Gasoline Engine**

Dear Audi Owner,

This notice is sent to you in accordance with the National Traffic and Motor Vehicle Safety Act. Audi has decided that a defect, which relates to motor vehicle safety, exists in certain 2015 model year Audi A3 vehicles equipped with a gasoline engine. Our records show that you are the owner of a vehicle affected by this action.

What is the issue? On some vehicles, contamination due to improper nickel plating of certain subcomponents within the fuel pump may cause excessive pump friction, potentially resulting in an inoperative fuel pump. If the fuel pump becomes inoperative due to this condition, it may result in a no-start condition or a stall while driving without warning, and without the ability to restart the vehicle. An engine stall without warning while driving can increase the risk of a crash.

What will we do? To help identify/correct this defect, your authorized Audi dealer will inspect and, if necessary, replace the fuel delivery unit. This work will take about two hours to complete and will be performed for you free of charge.

What should you do? Please contact your authorized Audi dealer without delay to schedule this recall repair. Please keep in mind that your dealer may need additional time for the preparation of the repair, as well as to accommodate their daily workshop schedule.

When you arrive for your service appointment, please ensure that your vehicle's fuel tank is at least one-quarter full.

Lease vehicles and address changes If you are the lessor and registered owner of the vehicle identified in this action, the law requires you to forward this letter immediately via first-class mail to the lessee within ten (10) days of receipt. If you have changed your address or sold the vehicle, please fill out the enclosed prepaid Owner Reply card and mail it to us so we can update our records.

Reimbursement of Expenses If you have previously paid for repairs relating to the condition described in this letter, the enclosed form explains how to request reimbursement. We would be pleased to review your reimbursement request.

Can we assist you further? If your authorized Audi dealer fails or is unable to complete this work free of charge within a reasonable time, please call or write to:

Audi of America, Inc.,
Attn: Customer Experience (20V5)
3800 Hamlin Road, Auburn Hills, MI 48326
1-800-253-2834
www.audiusa.com

Checking your vehicle for open Recalls and Service Campaigns To check your vehicle's eligibility for repair under this or any other recall/service campaign, please visit the **Recall/Service Campaign Lookup** tool at www.audiusa.com and enter your Vehicle Identification Number (VIN). As always, if you have any questions or if you need additional assistance, please contact Customer Experience or your authorized Audi dealer.

If you still cannot obtain satisfaction, you may file a complaint with: The Administrator, National Highway Traffic Safety Administration, 1200 New Jersey Avenue, SE., Washington, DC 20590; or call the toll-free Vehicle Safety Hotline at 1-888-327-4236 (TTY: 1-800-424-9153); or go to <http://www.safercar.gov>.

We apologize for any inconvenience this matter may cause; however we are taking this action to help ensure your safety and continued satisfaction with your vehicle. Thank you for your continued loyalty!

Sincerely,

Audi Customer Protection

Customer Letter Example (CANADA)

<MONTH YEAR>

<CUSTOMER NAME>

<CUSTOMER ADDRESS>

<CUSTOMER CITY STATE ZIPCODE>

This notice applies to your vehicle: <VIN>

**Subject: Safety Recall 20V5 – Fuel Delivery Unit
2015 Model Year Audi A3 with Gasoline Engine**

Dear Audi Owner,

This notice is sent to you in accordance with the requirements of the Motor Vehicle Safety Act. Audi has decided that a defect, which relates to motor vehicle safety, exists in certain 2015 model year Audi A3 vehicles equipped with a gasoline engine. Our records show that you are the owner of a vehicle affected by this action.

- What is the issue?** On some vehicles, contamination due to improper nickel plating of certain subcomponents within the fuel pump may cause excessive pump friction, potentially resulting in an inoperative fuel pump. If the fuel pump becomes inoperative due to this condition, it may result in a no-start condition or a stall while driving without warning, and without the ability to restart the vehicle. An engine stall without warning while driving can increase the risk of a crash.
- What will we do?** To help identify/correct this defect, your authorized Audi dealer will inspect and, if necessary, replace the fuel delivery unit. This work will take about two hours to complete and will be performed for you free of charge.
- What should you do?** Please contact your authorized Audi dealer without delay to schedule this recall repair. Please keep in mind that your dealer may need additional time for the preparation of the repair, as well as to accommodate their daily workshop schedule.
- When you arrive for your service appointment, please ensure that your vehicle's fuel tank is at least one-quarter full.
- Lease vehicles and address changes** If you are the lessor and registered owner of the vehicle identified in this action, the law requires you to forward this letter immediately via first-class mail to the lessee within ten (10) days of receipt. If you have changed your address or sold the vehicle, please fill out the enclosed prepaid Owner Reply card and mail it to us so we can update our records.
- Reimbursement of Expenses** If you have previously paid for repairs relating to the condition described in this letter, the enclosed form explains how to request reimbursement. We would be pleased to review your reimbursement request.
- Can we assist you further?** If your authorized Audi dealer fails or is unable to complete this work free of charge within a reasonable time, please call or write to:

Audi Canada
Attn: Customer Relations (20V5)
PO Box 842, Stn. A
Windsor, ON N9A 6P2
1-800-822-2834
www.audi.ca

We apologize for any inconvenience this matter may cause; however we are taking this action to help ensure your safety and continued satisfaction with your vehicle. Thank you for your continued loyalty!

Sincerely,

Audi Customer Protection

Required Parts

<u>Quantity</u>	<u>Part Number</u>	<u>Part Description</u>
1	5Q0919087R	Fuel Delivery Unit (quattro)
1	1J0919133B	Gasket Seal (ALL)

Required Tools



- Trim Removal Wedge - 3409



- Fuel Extracting Device – VAS5190
- OR**
- Fuel Extracting Device – VAS5190A (for vehicles filled with E85 fuel)



- Engine Bung Set – VAS6122

- Lever – Fuel Line – T10468



- Wrench – Fuel Sending Unit – T10202



Work Procedure

Applicable Criteria ID (s)	Campaign/Action Status
01	Open

EXAMPLE

Section A – Check for Previous Repair

- Enter the VIN in Elsa and proceed to the “Campaign/Action” screen

TIP

On the date of repair, print this screen and keep a copy with the repair order.

- Ensure that the Status is “Open” <arrow 2>
- Note the Applicable Criteria ID <arrow 1> for use in determining the correct work to be done and corresponding parts associated

Proceed to Section B

Section B – Inspect Fuel Delivery Unit

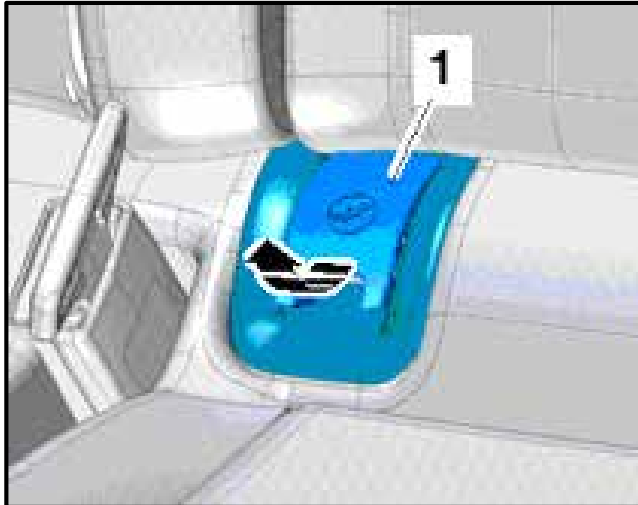

- Move the front seats to the full forward position.
- Unclip and remove the cover <1> from each child seat anchor <direction of arrow>.

CAUTION

Edges on the child seat anchor cover may be sharp.

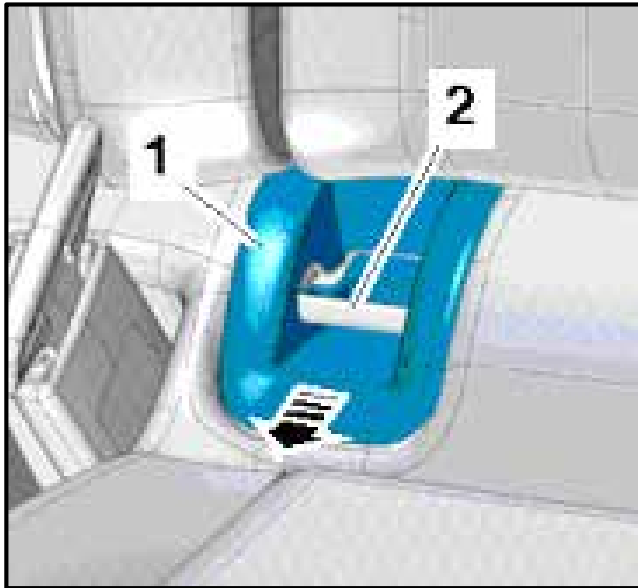

- Press straight downward on the guide <1> to disengage it from the child seat anchor <2>.
- Slide the guide <1> forward <direction of arrow> to remove it.
- Repeat these steps on the remaining three child seat anchor covers and guides.

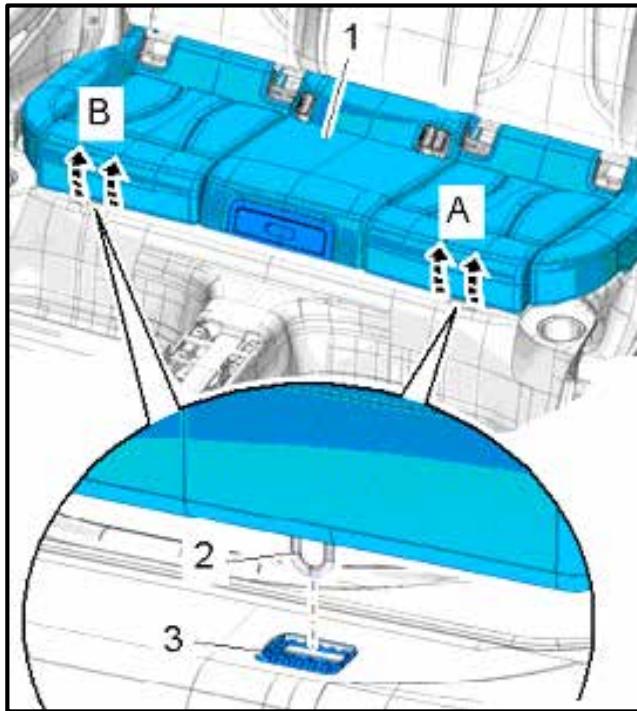

- Using both hands, grasp the rear bench seat under the seat frame.
- Pull the rear bench seat <1> upward with both hands <direction of arrows A and B> so the wire hooks <2> on the rear bench seat release from the mounting grommets <3>.
- Remove the rear bench seat from the vehicle.

NOTE

Place the seat bench in a clean location where it will not be damaged. Damage to the seat bench is not covered under this action.



TIP

The rear frame of the seat bench engages locking fingers <circle> mounted to the vehicle body. During removal, it may be necessary to push the seat bench rearward slightly to disengage the locking fingers.

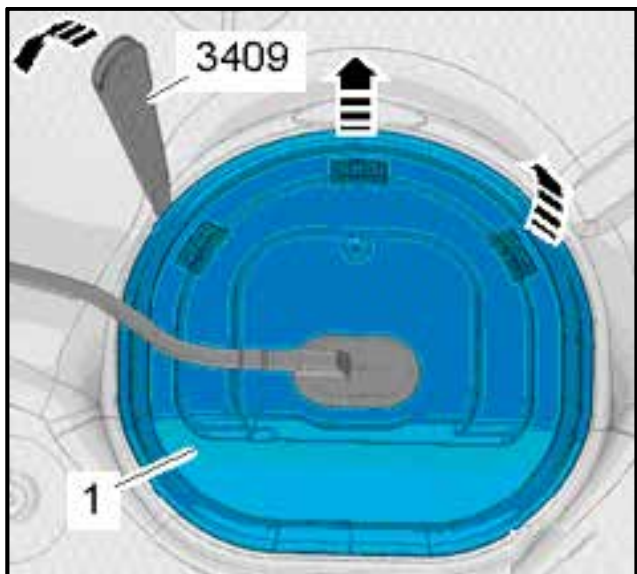

- Using the Trim Removal Wedge 3409 (or equivalent), gently pry up on the **REAR** edge of the fuel delivery unit access cover <1> as shown <direction of arrows>, and release the cover from the vehicle body.

TIP

Some vehicles are equipped with an access cover on both sides of the vehicle under the rear seat bench. For this procedure, it is only necessary to remove the passenger side cover.

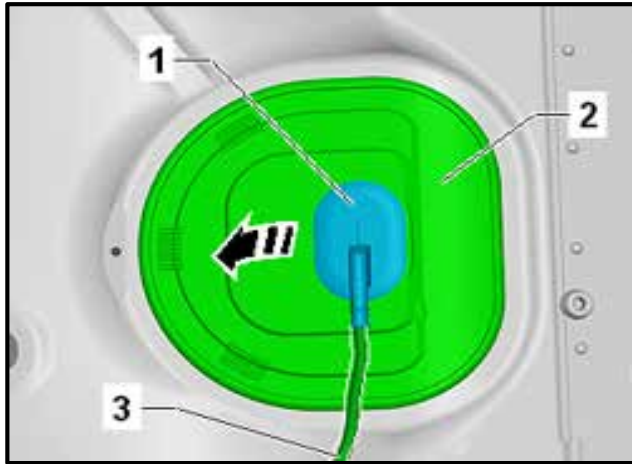

- Press the grommet <1> downward out of the cover <2>.
- Lift the cover <2> away from the fuel delivery unit access cutout.
- Slide the cover along the wiring harness <3> until it is positioned out of the way.



- Locate the label on top of the fuel delivery unit.
- Inspect the part number and build date of the fuel delivery unit <circles>.
- If the part number and build date are listed in the chart below, the fuel delivery unit **MUST** be replaced, **Proceed to Section C.**

NOTE
Record production date on repair order to be included on claim entry.

- If the part number and build date are **NOT** listed in the chart below, no further work is required, reassemble the vehicle and **Proceed to Section E.**

NOTE
Record production date on repair order to be included on claim entry.

NOTE
The electrical connector was removed in this step for picture clarity. It is **NOT** necessary to disconnect the wiring harness during this inspection step.

Part Number	Production Date – Replace fuel sending unit ONLY if the production date matches one of the numbers below:		
5Q0 919 051 AQ (Quattro)	010314	050114	080314
	020314	050314	090314
	030114	060114	100314
	030314	060314	101213
	040114	070114	270214
	040314	070314	280214

The repair information in this document is intended for use only by skilled technicians who have the proper tools, equipment and training to correctly and safely maintain your vehicle. These procedures are not intended to be attempted by "do-it-yourselfers," and you should not assume this document applies to your vehicle, or that your vehicle has the condition described. To determine whether this information applies, contact an authorized Audi dealer. © 2015 Audi of America, Inc. and Audi Canada. All Rights Reserved.



Section C – Inspect Fuel Level

- Switch the ignition ON.
- Inspect the current fuel gauge reading.
- If the fuel gauge is **AT or ABOVE 3/4** <as shown>, the fuel tank must be partially drained prior to removing the fuel delivery unit, **Proceed with Section C.**
- If the fuel gauge is **BELOW 3/4**, the fuel delivery unit can be removed without performing this portion of the fuel draining procedure. **Proceed to Section D – Fuel Delivery Unit Replacement.**

! NOTE

Use only the Fuel Extractor Unit VAS 5190A when extracting E85 fuel from the vehicle.

! WARNING

There is a risk of injury because the fuel is under high pressure. Injury from fuel spraying is possible.

! WARNING

Burn risk due to escaping fuel. With the battery connected, the door contact switch activates the fuel pump when opening the driver door. Escaping fuel can ignite and lead to a fire.

! NOTE

Observe these rules when working on the fuel supply/injector system:

- Thoroughly clean the connecting points and the surrounding area before loosening.
- Place the removed parts on a clean surface and cover them. Only use lint-free cloths.
- Carefully cover or seal opened components if the repair will not be done immediately.
- Only install clean parts: remove replacement parts from the packaging immediately prior to installation. Do not use parts that have been stored loose (for example, in tool boxes etc.)

- When the system is open, do not work with compressed air.
- Do not move the vehicle.
- Seal off any open lines and connections immediately with plugs, for example, take from Engine Bung Set VAS6122.
- Protect the disconnected connectors from dirt and moisture and only connect when they are dry.

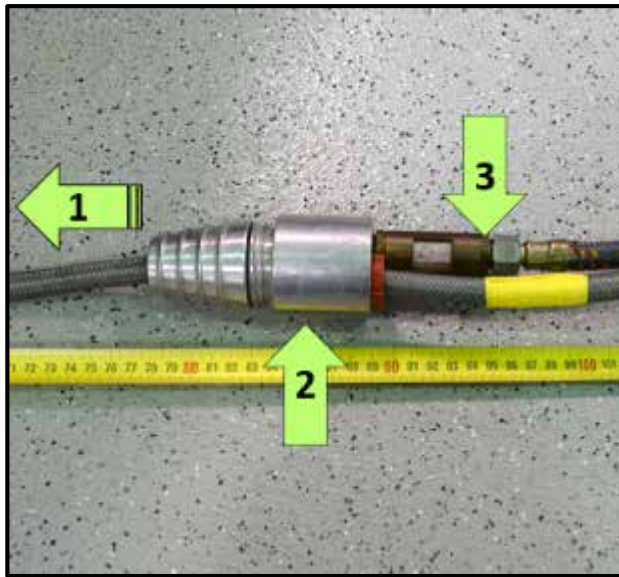

- Measure 945mm from the open end of the Fuel Extractor Unit VAS 5190 extraction hose <arrow 1>.
- Position the fuel filler hose adapter <arrow 2> between the 945mm point and the end of the extraction hose.
- Using masking tape, or equivalent, make a mark <arrow 3> at the 945mm point on the extraction hose of the VAS 5190.

! NOTE

When properly assembled, the fuel filler hose adapter <arrow 2> should be located between the tape mark <arrow 3> and the end of the extraction hose <arrow 1>. To avoid possible fuel contamination, the tape must not come in contact with fuel or enter the fuel filler tube during these steps.

- Open the fuel filler door.
- Clean the area around the fuel filler tube.
- Remove the fuel cap from the fuel filler tube.
- Attach the Fuel Extracting Device VAS5190 ground cable to an ungrounded area on the body.



- Insert the extraction hose and fuel filler hose adapter on the VAS5190 into the fuel filler tube until the marking made previously <arrow> aligns with the fuel filler tube adapter as shown.
- Drain the fuel tank as much as possible through the fuel filler tube.

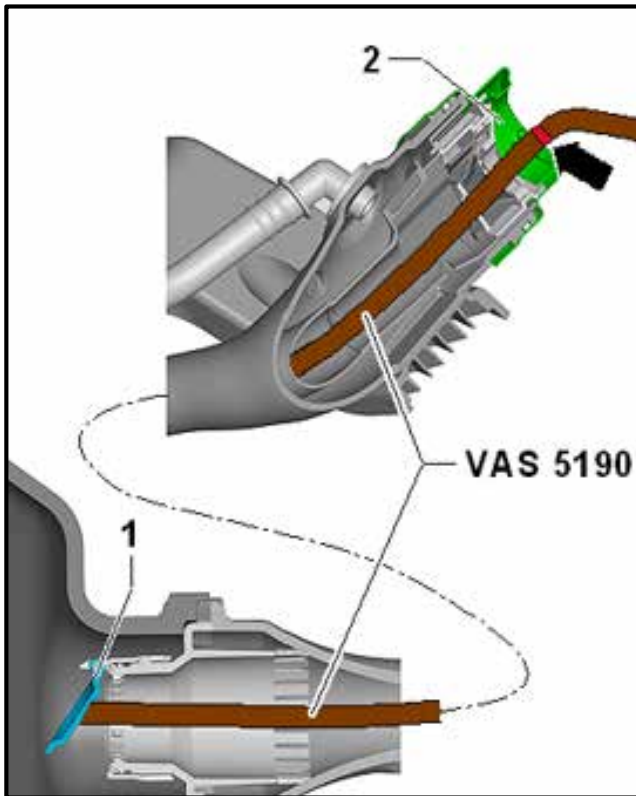

NOTE

- A flap <1> is located in the fuel tank on the lower end of the fuel filler tube. It must not be damaged by the extraction hose. Only slide the hose into the fuel filler tube until the tape mark lines up with the top of the fuel filler tube <arrow>.
- Do not use force to pull the extraction hose if it gets stuck on the check valve.
- If the extraction hose becomes lodged in the check valve, remove the fuel delivery unit manually and hold the check valve open.

- Remove the extracting hose carefully.

NOTE

- When no more fuel can be extracted, the tank is emptied only enough for the fuel delivery unit to be removed without fuel spilling out.

Proceed to Section D – Fuel Delivery Unit Replacement

Section D – Fuel Delivery Unit Replacement



- Prior to disassembly, the fuel delivery unit **MUST** be clean. If excessive dirt or debris is present <as shown>, clean and dry the fuel delivery unit and surrounding areas as necessary.

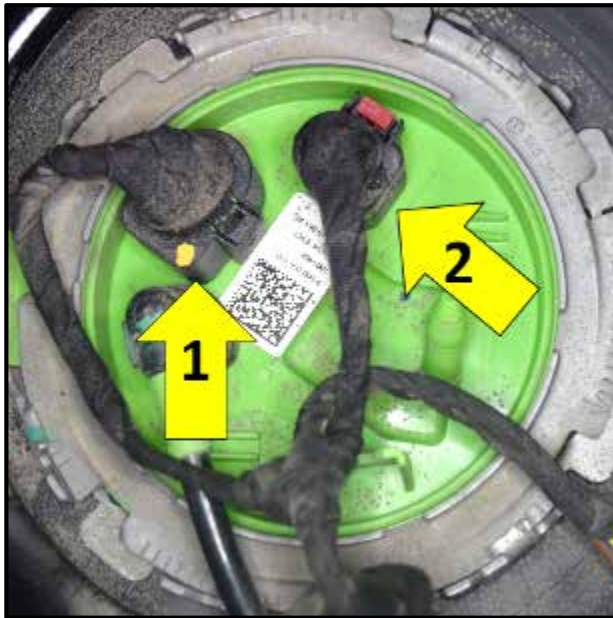

- Switch the ignition OFF.
- Open the hood.
- Disconnect and isolate the negative battery cable.
- At the fuel delivery unit, unlock and disconnect the connectors <arrows 1 and 2> from the locking flange.

! NOTE

- On front wheel drive vehicles, only one electrical connection <arrow 1> is present.

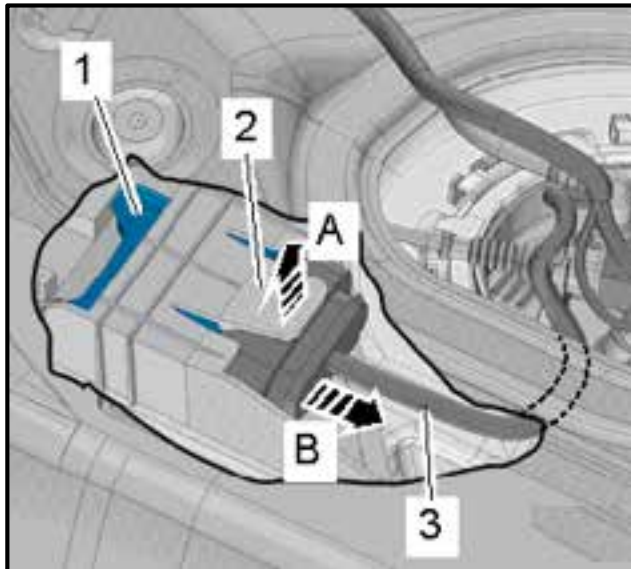

- Lift the tab <2> upward <direction of arrow A>.
- At the same time, pull the Fuel Pump Control Module J538 <1> forward out of the mounting bracket <direction of arrow B>.
- Position the Fuel Pump Control Module J538 to the side to allow adequate slack in the wiring harness.



- Disconnect the fuel line <arrow> from the locking flange.

⚠ WARNING

Fuel Lines are under pressure. Danger of personal injury to eyes and skin. Wear protective eyewear and protective clothing in order to avoid injury and contact with the skin. Wrap a cloth around the connection **before** loosening hose connections. Open the connection carefully and release the pressure.



- Remove the locking ring using the Wrench – Fuel Sending Unit – T10202 <as shown>.

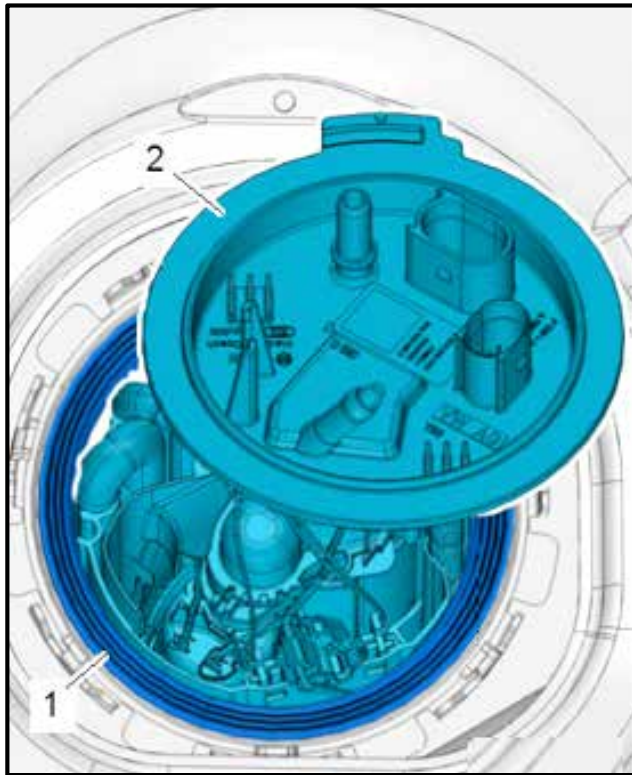

On vehicles with quattro all-wheel drive:

- Lift the right sealing flange <2> slightly out of the fuel tank opening.
- Remove the seal <1> from the fuel tank opening.

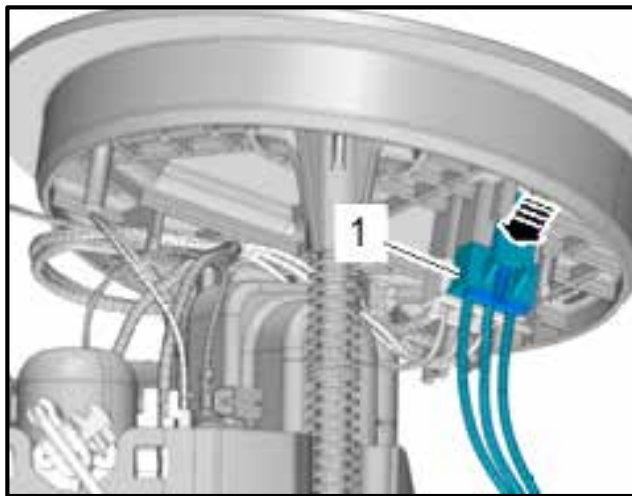

- Release the electrical connector <1> as shown <direction of arrow>.



i TIP
 To avoid dropping the electrical connector and wiring harness into the fuel tank, the harness can be taped to the side <as shown>.



- Position the fuel delivery unit to the side.
- Insert the extraction hose from the VAS5190 into the fuel tank.
- Drain additional fuel out of the tank until the fuel level reaches approximately ¼ tank.
- Insert the extraction hose into the fuel delivery unit <arrow>.
- Drain as much fuel as possible from the fuel delivery unit itself.

! NOTE

The fuel tank and sending unit **MUST** be drained during these steps. This will help to prevent excess fuel from spilling into the vehicle.



- Lay a cloth inside the vehicle to absorb any residual fuel.
- Turn and tilt the fuel delivery unit <1> with the fuel level sensor <2> as necessary to remove it through the opening in the fuel tank.

! NOTE

- The fuel delivery unit cannot be fully removed from the fuel tank at this point. Lift the fuel delivery unit high enough to access the lines from the suction jet pump as shown.
- Be careful when moving the fuel lines during this step. Fuel lines can be damaged with excessive force. Damage to the in-tank fuel lines is not covered under this action.

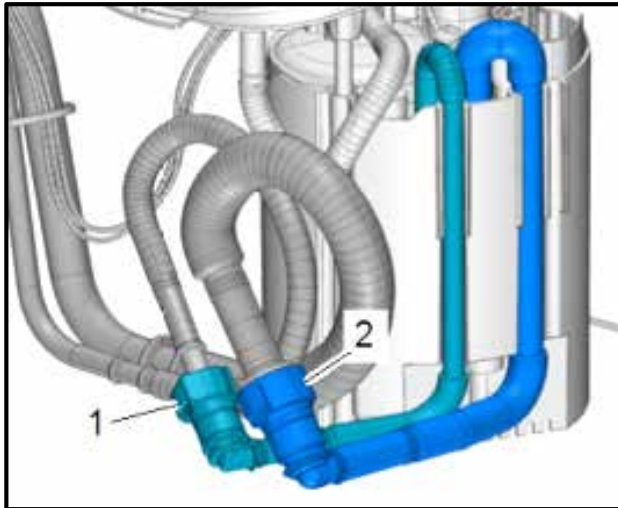

- Disconnect the suction jet line <1> and the delivery line <2> from the fuel delivery unit fittings.
- Remove the fuel delivery unit from the vehicle.

! NOTE

- The fuel delivery unit must be drained prior to removal.
- Follow all gasoline disposal regulations.
- Inspect the fuel tank for visible contamination.
- Inspect the fuel line couplings and seals for any damage – replace seals if damaged.

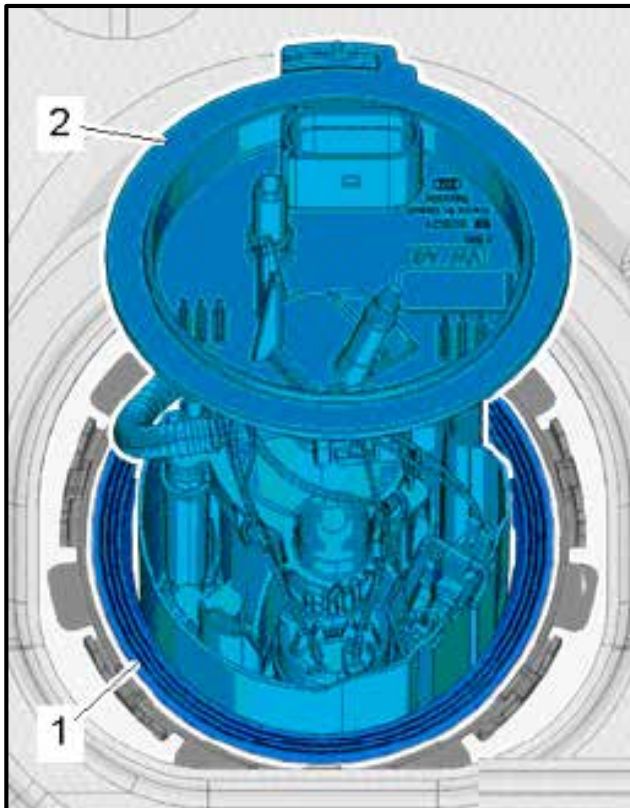

On FWD vehicles:

REPAIR NOT AVAILABLE AT THIS TIME

- Pull the locking flange <2> out of the opening in the fuel tank slightly.
- Remove seal <1> on the opening in the fuel tank.



- Position the fuel delivery unit to the side.
- Insert the extraction hose from the VAS5190 into the fuel tank.
- Drain additional fuel out of the tank until the fuel level reaches approximately ½ tank.
- Insert the extraction hose into the fuel delivery unit <arrow>.
- Drain as much fuel as possible from the fuel delivery unit itself.

! NOTE

The fuel tank and sending unit **MUST** be drained during these steps. This will help to prevent excess fuel from spilling into the vehicle.



- Lay a cloth inside the vehicle to absorb any residual fuel.
- Carefully pull the fuel delivery unit with Fuel Level Sensor -G- out through the opening in the fuel tank.
- Turn and tilt the fuel delivery unit as needed.
- Disconnect the breather tube <circle> from the bottom of the fuel delivery unit.
- Remove the fuel delivery unit from the vehicle.

! NOTE

- The fuel delivery unit must be drained prior to removal.
- Follow all gasoline disposal regulations.
- Inspect the fuel tank for visible contamination.
- Inspect the fuel line couplings and seals for any damage – replace seals if damaged.

On FWD vehicles:

REPAIR NOT AVAILABLE AT THIS TIME

- Place the new fuel delivery unit seal, P/N: 1J0919133B <1> around the fuel tank opening as shown. The seal should be installed dry.
- Coat the inside of the installed seal <1> with fuel.
- Position the new fuel delivery unit into the fuel tank.

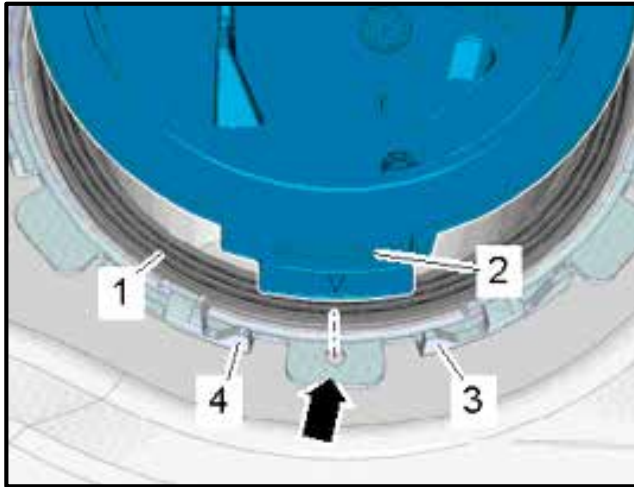

⚠ CAUTION
Be careful not to bend the fuel level sensor when installing the fuel delivery unit.

- Position the locking flange <2> between the alignment tabs <3 and 4>.
- Align the marks between the locking flange and the fuel tank as shown <arrow>.

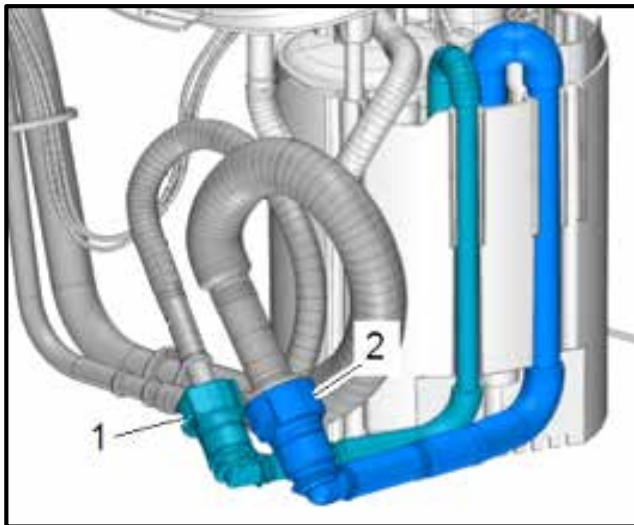

On vehicles with quattro all-wheel drive:

- Position the new fuel delivery unit, P/N: 5Q0919087R near the fuel tank opening.
- Reconnect the suction jet line <1> and the delivery line <2> to the fuel delivery unit fittings.
- Carefully insert the new fuel delivery unit into the fuel tank.



- During installation, the fuel delivery unit **MUST NOT** be turned inside the fuel tank.
- Align the locking flange <arrow> with the mark on the fuel tank <circle> **PRIOR** to inserting the fuel delivery unit into the fuel tank opening.

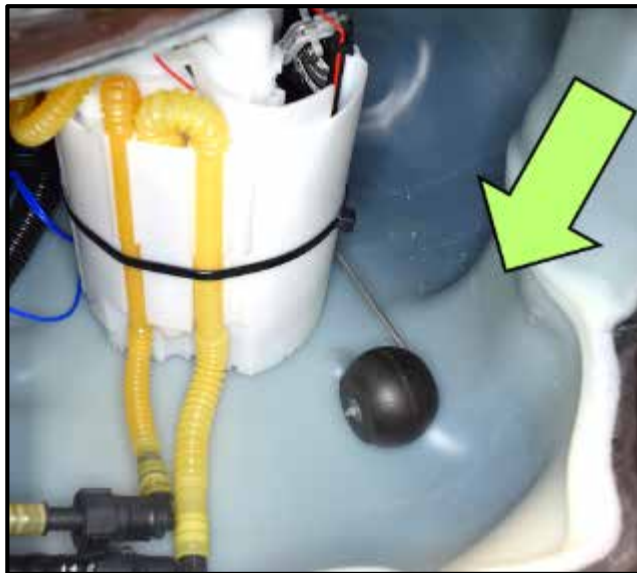

- During installation of the fuel delivery unit, the float arm for the fuel level sensor can hang up on the indentation in the fuel tank <arrow>. The fuel delivery unit **MUST** be properly aligned prior to fully inserting it into the fuel tank.

⚠ CAUTION

During installation of the fuel delivery unit, it is very easy to damage the fuel level sensor. Use caution when inserting the fuel delivery unit. Damage to the fuel level sensor is not covered under this action.

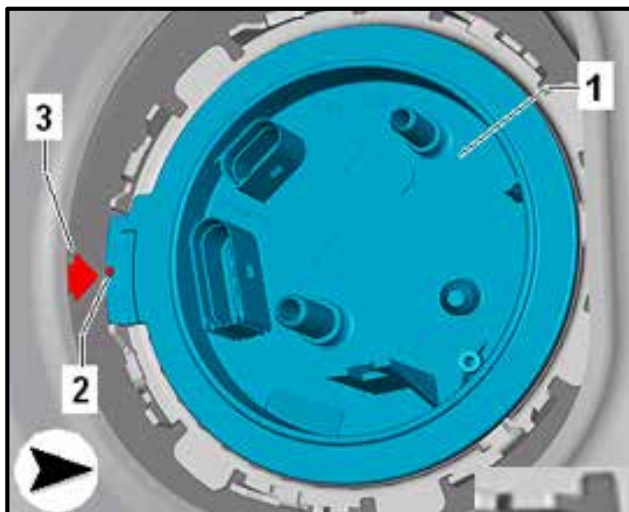

On all vehicles:

- Press the top of the fuel delivery unit down into the fuel tank opening.
- The arrow <3> on the fuel tank must point to the mark <2> on the locking flange <1>.

ⓘ NOTE

When inserting the sealing flange, the sealing ring must not be damaged or crushed.



- Install the locking ring, and tighten using the Wrench – Fuel Sending Unit – T10202, and torque to 110Nm.



- Attach the fuel line <1> to the locking flange until it clicks into place.

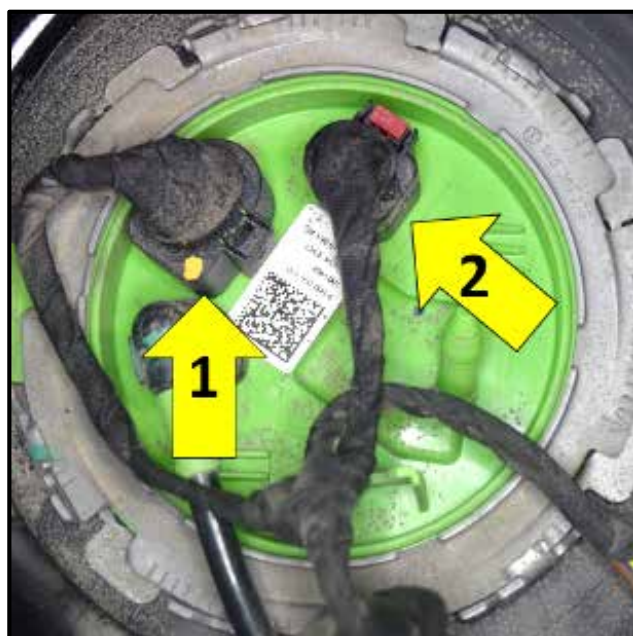

- Securely refasten the connectors <arrows 1 and 2>.

! NOTE	
•	On front wheel drive vehicles, only one electrical connection <arrow 1> is present.

- Reinstall the fuel pump control module.
- Reinstall the fuel delivery unit access cover.
- Refasten the wiring harness grommet into the cover.
- Reinstall the rear bench seat.
- Reinstall the child seat anchor covers.
- Reconnect the vehicle battery.

- Switch the ignition ON.
- Attach an appropriate VAS tester to the vehicle.
- Clear all DTCs.
- Reset customer convenience basic settings (i.e. one touch windows, instrument cluster clock, etc.).
- Refill the fuel tank with any fuel that was extracted previously.

Proceed to Section E

Section E – Campaign Stamp

I certify that this campaign
has been performed in strict
accordance with the applicable
Audi repair procedure.

SAGA Code: _____

Technician: _____

Date: _____

Item#: AUD4927ENG

- Once the campaign has been completed, the technician should stamp the repair order.
- Stamps are available for ordering through the Compliance Label Ordering Portal.

OR

Je certifie que cette
campagne de rappel a été
exécutée suivant les strictes
directives de réparation
d'Audi

Code de SAGA: _____

Technicien: _____

Date: _____

Item # AUD4927FRE

Proceed to Section D

Section D – Parts Return/Disposal

Parts Return/Disposal

Properly destroy or dispose of removed parts in accordance with all state and local requirements, unless otherwise indicated and/or requested through the Warranty Parts Shipping Portal (WPSP) for U.S. and SAGA for Canada.

ALL WORK IS COMPLETE