

Reference:

ITB17-011

Date:

February 23, 2017

VOLUNTARY SAFETY RECALL CAMPAIGN 2003-2004 I35, 2006 M, AND 2003-2005 FX35/45 FRONT PASSENGER AIR BAG INFLATOR

CAMPAIGN ID #: R1706
NHTSA #: 15V-226
APPLIED VEHICLES: 2003-2004 I35 (CA33)
2003-2005 FX35/45 (S50)
2006 (Y50)

Check Service COMM to confirm campaign eligibility.

- There are multiple bulletins with different campaign ID numbers for the front passenger air bag inflator.
- Each bulletin is applicable to specific vehicles.
- Make sure the correct bulletin (Campaign ID #) is being used.

INTRODUCTION

Infiniti is conducting a Voluntary Safety Recall Campaign on model year 2003-2004 I35, 2003-2005 FX35/45, and 2006 M vehicles to replace the front air bag Programmable Smokeless Passenger Inflator (PSPI). This service will be performed at no charge to customers for parts or labor.

Takata has issued return packaging, shipping labels, documents, and directions that must be used and followed in order to properly carry out this campaign. Takata's documentation is attached and is part of this bulletin.

IDENTIFICATION NUMBER

Infiniti has assigned identification number R1706 to this campaign. This number must appear on all communication and documentation of any nature dealing with this campaign.

DEALER RESPONSIBILITY

It is the dealer's responsibility to check Service Comm for the campaign status on each vehicle falling within the range of this voluntary safety recall which for any reason enters the service department. This includes vehicles purchased from private parties or presented by transient (tourist) owners and vehicles in a dealer's inventory. **Federal law requires that new vehicles in dealer inventory which are the subject of a safety recall must be corrected prior to sale. Failure to do so can result in civil penalties by the National Highway Traffic Safety Administration.** While federal law applies only to new vehicles, Infiniti strongly encourages dealers to correct any used vehicles in their inventory before they are retailed.

Infiniti Bulletins are intended for use by qualified technicians, not 'do-it-yourselfers'. Qualified technicians are properly trained individuals who have the equipment, tools, safety instruction, and know-how to do a job properly and safely. NOTE: If you believe that a described condition may apply to a particular vehicle, DO NOT assume that it does. See your Infiniti retailer to determine if this applies to your vehicle.

REQUIRED SPECIAL TOOLS

Air Bag Module Support (J-51315-KIT)

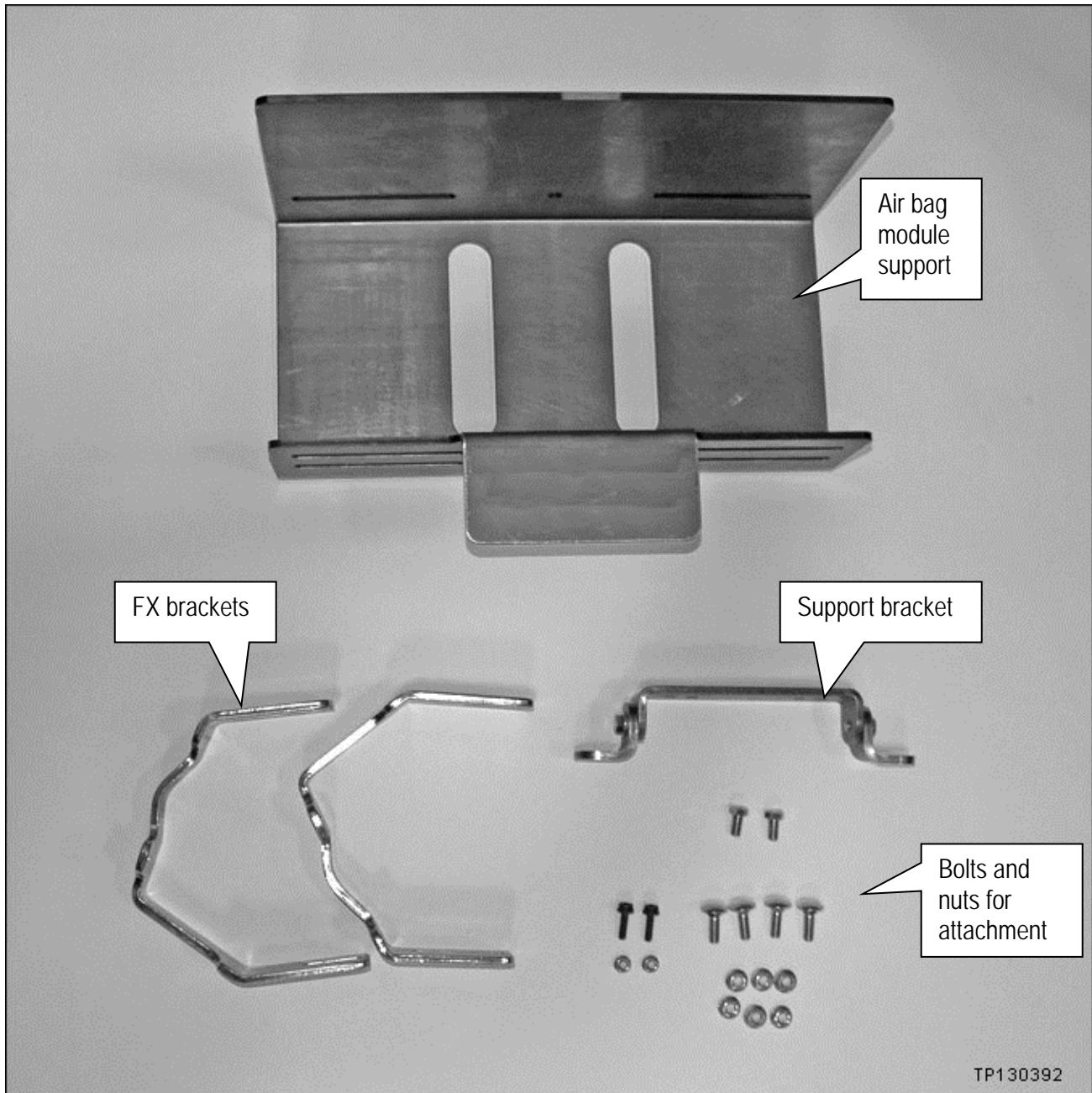

Figure A

REQUIRED SPECIAL TOOLS continued

Quick Scan Tool (J-52352)

- Each retailer has been shipped one Quick Scan Tool (J-52352).
- Additional tools can be obtained from Tech•Mate at 1-800-662-2001.



Figure B

SERVICE PROCEDURE

1. Write down the radio settings.

Presets	1	2	3	4	5	6
AM						
FM 1						
FM 2						
SAT 1						
SAT 2						
Bass	Treble		Balance		Fade	Speed Sen. Vol.

2. Turn the ignition OFF.
3. Disconnect both battery cables, negative cable first.
4. Wait at least 3 minutes.
5. Register the new inflator serial number as follows.
 - The new inflator is listed in the Parts Information.

- a. Attach the quick scan tool (J-52352) to your CONSULT PC USB port.

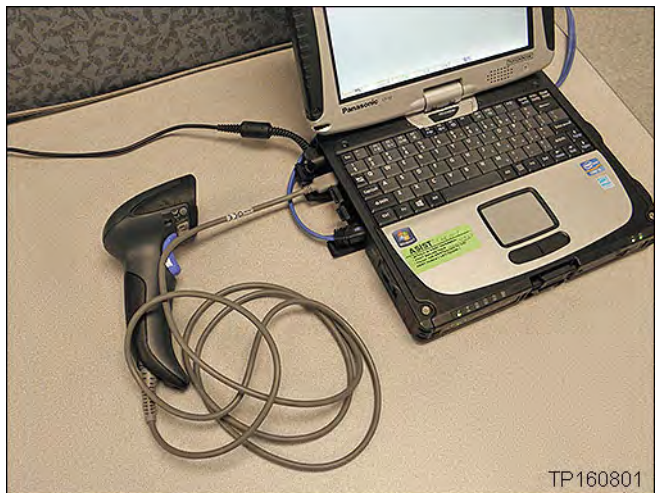

Figure 1

TP160801

- b. On the left side of the ASIST main menu, select Tech Support Info, then Inventory Vehicle Actions.

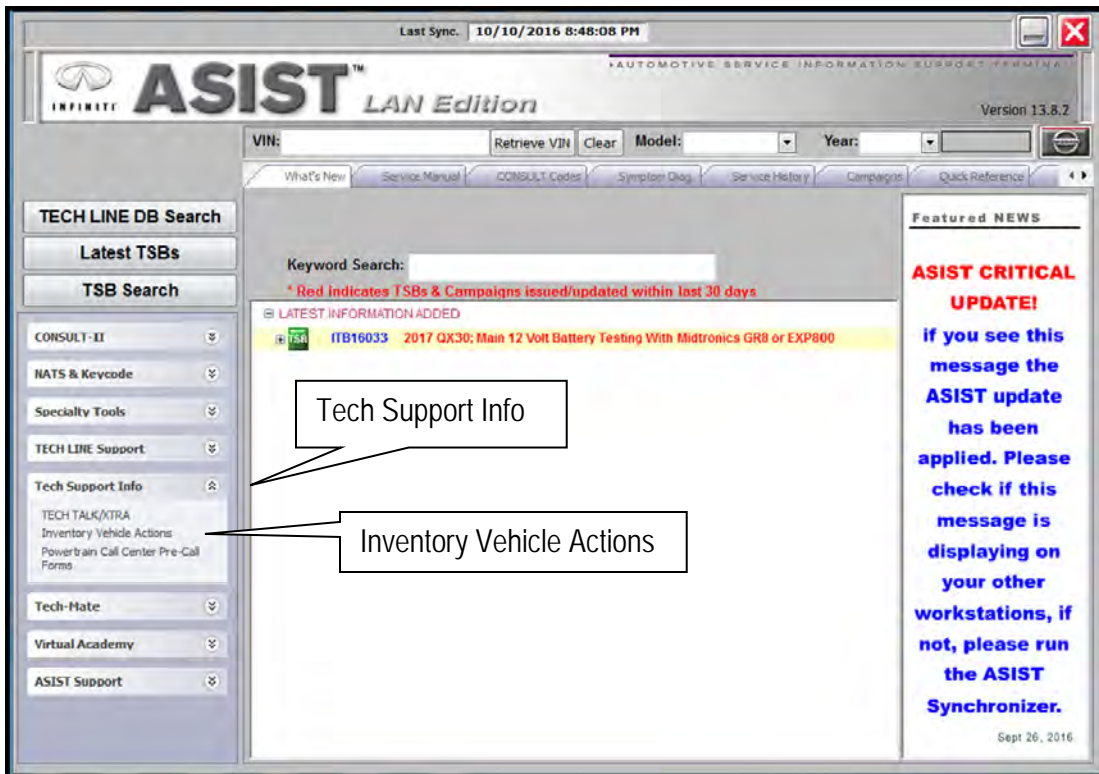

Figure 2

- c. Select **CLICK HERE** (Air Bag to VIN Registration).

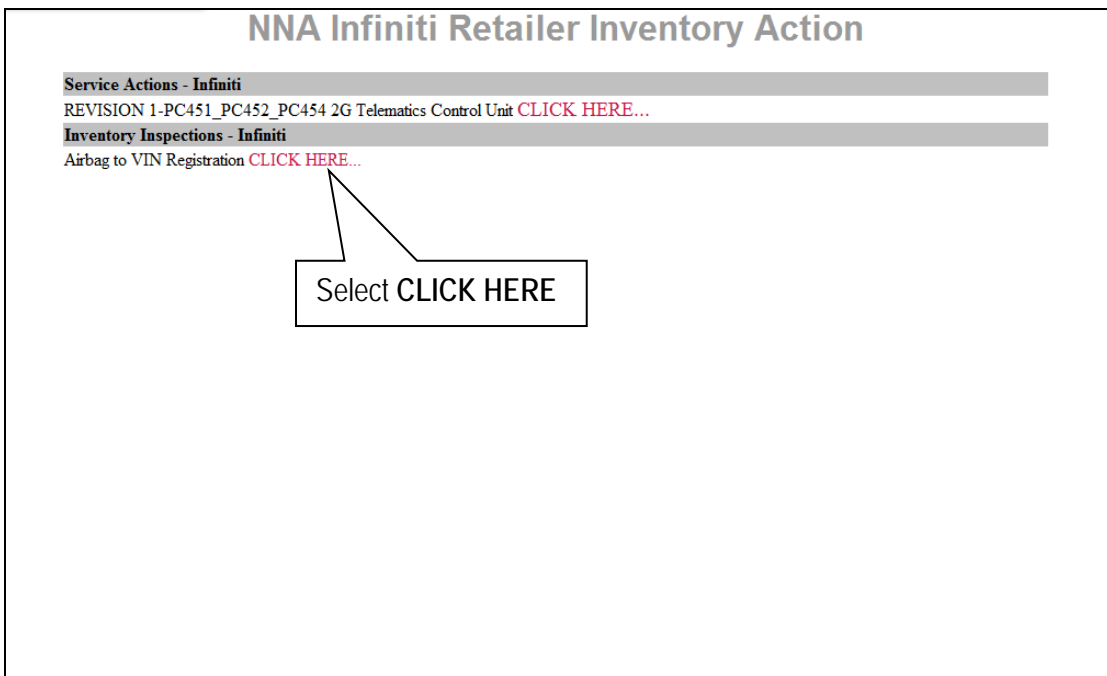

Figure 3

- e. Use the quick scan tool to scan the bar code (serial number) on the new inflator shipping box.
 - The serial number will automatically populate (see Figure 5 on previous page).

NOTE: If needed, the serial number can be entered manually.



Figure 6

- f. Select **Submit** on the ASIST screen (see Figure 5 on the previous page).
6. Remove the passenger air bag module (module) from the vehicle.
 - Refer to the appropriate Electronic Service Manual (ESM) for module removal information.

IMPORTANT: Follow all cautions, warnings, and notes in the Electronic Service Manual (ESM) when working on or near a Supplemental Restraint System (SRS), such as an air bag.

CAUTION: Handle interior trim carefully to avoid damage. Work with clean hands and clean tools to avoid dirt and stains. Use protective covers as needed.

7. Set the module in a clean working area.

NOTE: Do not set the module with cover facing down.
8. Securely mount the air bag module support (support) in a vice (see Figure 7).

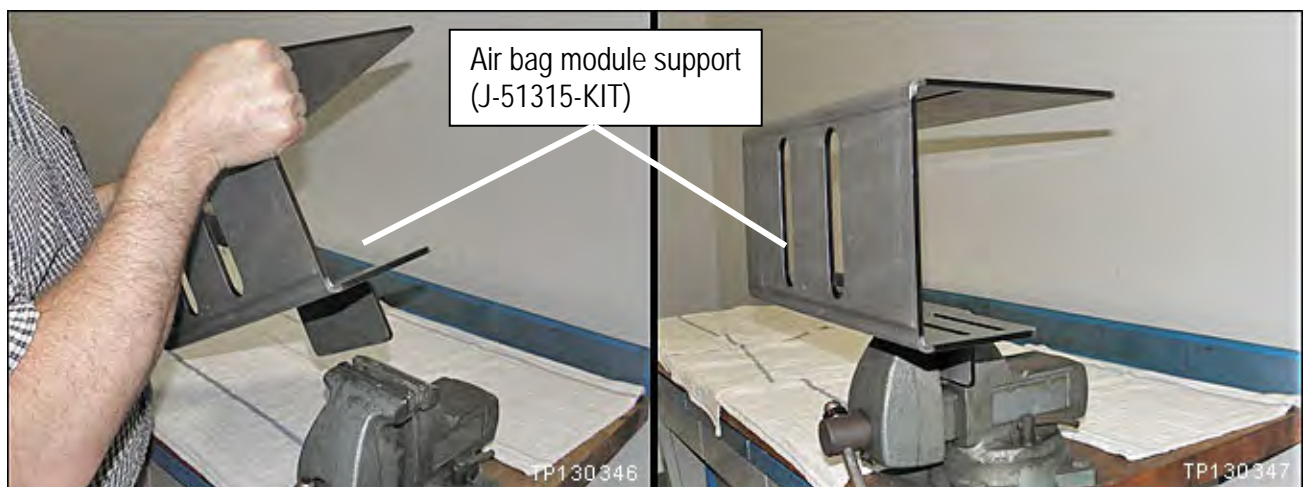

Figure 7

WARNING: Work from behind and to the sides of the support.

Remove the Inflator from the Air Bag Module Assembly

9. Replace the module Inflator:

- I35; page 9
 - FX; page 19
 - M; Page 28.
- IMPORTANT:** Connection of the new harness for the M is different than the I35 or FX. Make sure to read the harness connection instructions for each vehicle

10. Reinstall the module into the vehicle in reverse order of removal.

- Make sure to use the new “one time use” module mounting bolts included with the new inflator.

NOTE: For FX (per a Service Manual amendment – ITB13-023) only one air bag mounting bolt is “one time use”. This “one time use” bolt is included in the box with the FX inflator.

11. Re-connect both battery cables – positive cable first.

12. Reset the clock and the radio settings.

13. Turn the ignition ON and observe the air bag warning light:

- Light should illuminate for 7 seconds and then go out.

NOTE: If the Air Bag Warning light does not operate as described above there may be an issue not covered by this campaign. Refer to ASIST and the appropriate Service Manual for additional diagnostic and repair information.

14. Return the removed (old / non-deployed) inflator in the box that the new inflator arrived in.

- Follow the return instructions provided by Takata.
- Return instructions provided by Takata are attached to this bulletin on page 39

135 Inflator replacement

WARNING: Wear safety glasses while performing inflator replacement.

1. Set the module on a clean working area.
2. Disconnect the harness clip from the module frame.

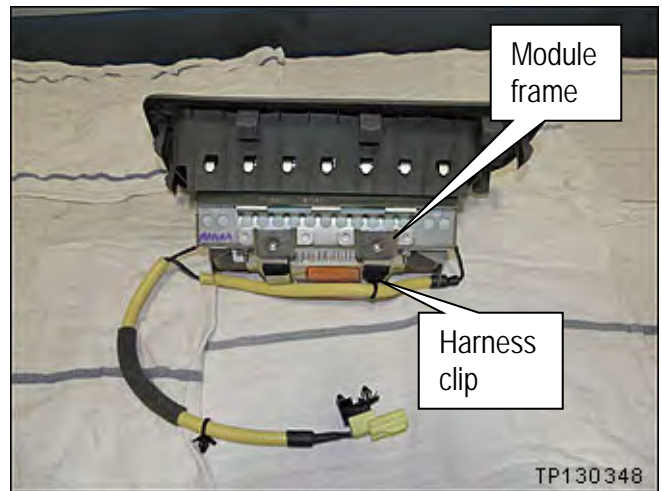

Figure M1

3. Attach the module support bracket to the module frame.
 - Tighten the bolts holding the bracket to the module frame.
 - Leave the L brackets on each end slightly loose to allow for positioning of the module in the support.

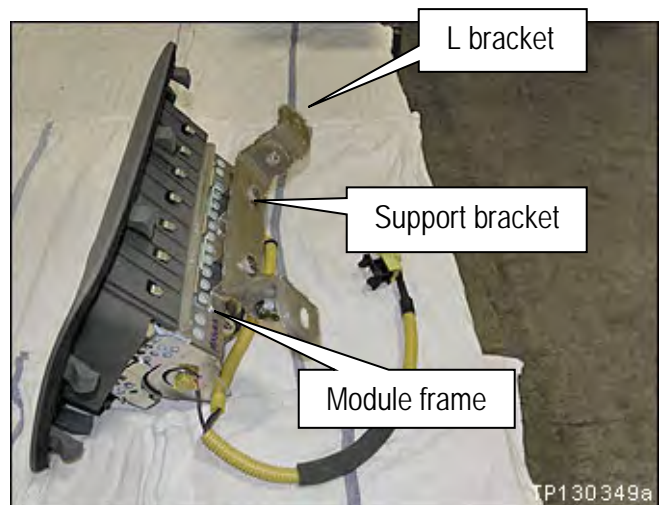

Figure M2

WARNING: Work from behind and to the sides of the support.

4. Mount the module in the support.

- Use bolts and nuts supplied with the support.

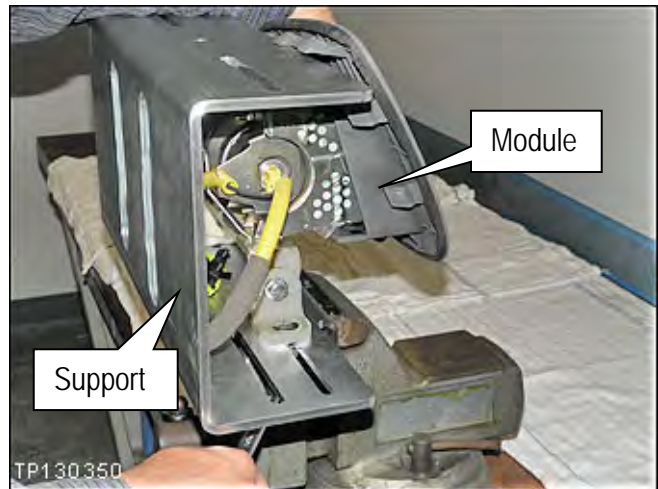

Figure M3

5. Make sure the module is centered in the support.

NOTE: Centering the module in the support will allow access to the inflator securing nuts through the slots in the support.

6. Tighten all of the mounting bolts and nuts that hold the module to the support.

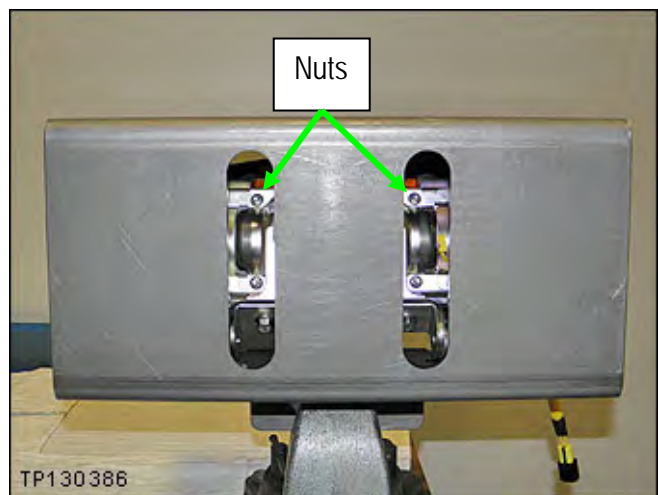

Figure M4

7. Carefully cut a few inches of the yellow corrugated harness cover in the area shown.

- **Do not** cut the wires inside the corrugated cover.

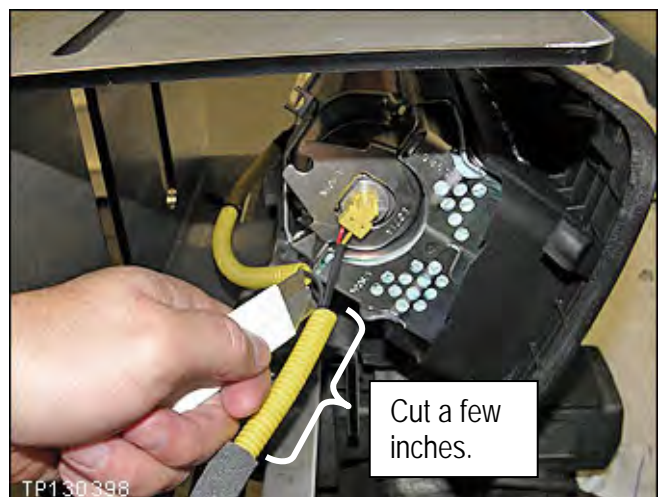

Figure M5

8. Attach 2 shorting pins to the inflator harness as shown.

- Make sure to pair the wires from each end of the inflator.

Blue with White

Red with Yellow

- Use an insulation displacement type wire connector as a shorting pin.
- Refer to the Parts Information for additional connector/shorting pin information.

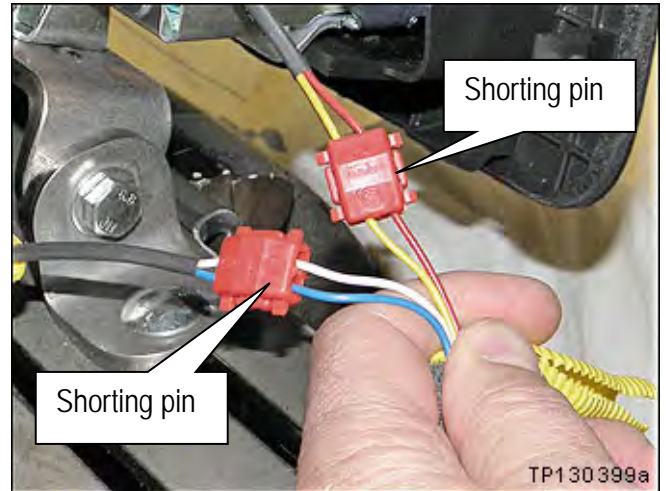

Figure M6

9. Cut off the connector end of the harness.



Figure M7

10. Remove the 4 nuts from the module that hold the inflator in place (see Figures M8 and M9).

- Use a ratchet and extension.



Figure M8

- Remove the 4 nuts.

NOTE: These nuts will not be reused.

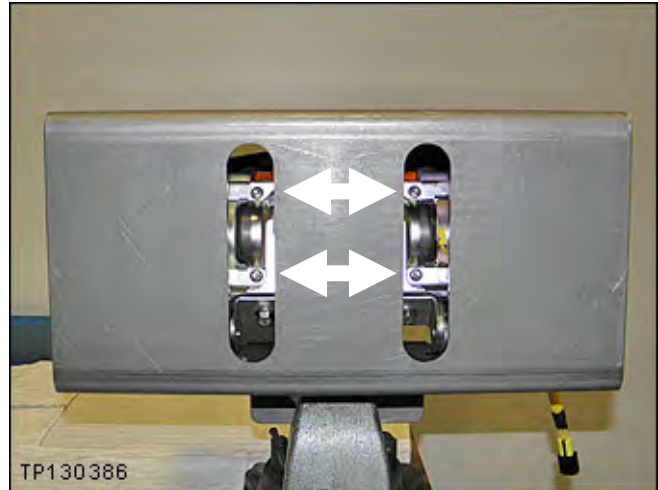

Figure M9

11. Remove the inflator stopper.



Figure M10

12. Push the right side of the inflator out of the module.

- Twist the inflator to a position that will allow the connector and harness to fit through the opening.



Figure M11

13. Pull the inflator completely out of the module from the left side.

14. Set the old inflator in the clean working area and make sure it does not roll and fall to the floor.

NOTE:

- Follow the return instructions provided by Takata, which are included in the box with the new inflator.
- Takata supplied return instructions are also attached to this bulletin on page 39.



Figure M12

15. Remove the new inflator from the box.

16. Slide the new inflator into the module from the left side.



Figure M13

17. Make sure the inflator is positioned / oriented correctly as shown.

- **The flat side of the inflator end (on the right side) must align with the flat side of the inflator housing.**

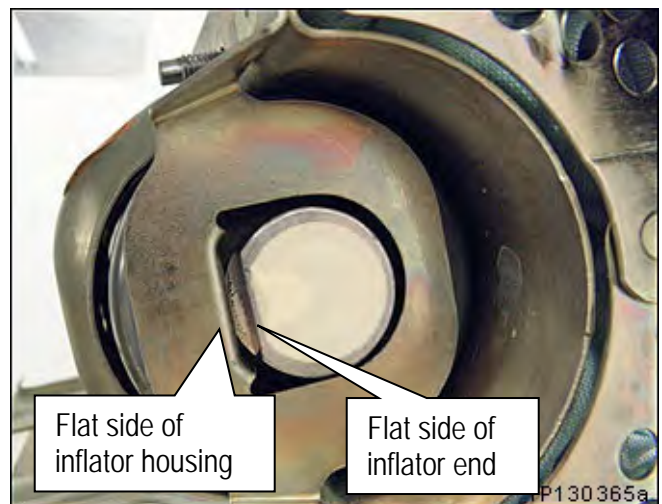

Figure M14

18. Install the inflator stopper and 4 inflator securing nuts finger tight (see Figure M15).

- Make sure to use **new nuts**.
- New nuts are included with the new inflator.

19. Make sure the inflator is pushed all the way into its housing – no gap on the right side (see Figure M15).

20. Make sure there is no gap between the inflator stopper and the inflator on the left side (see Figure M15).

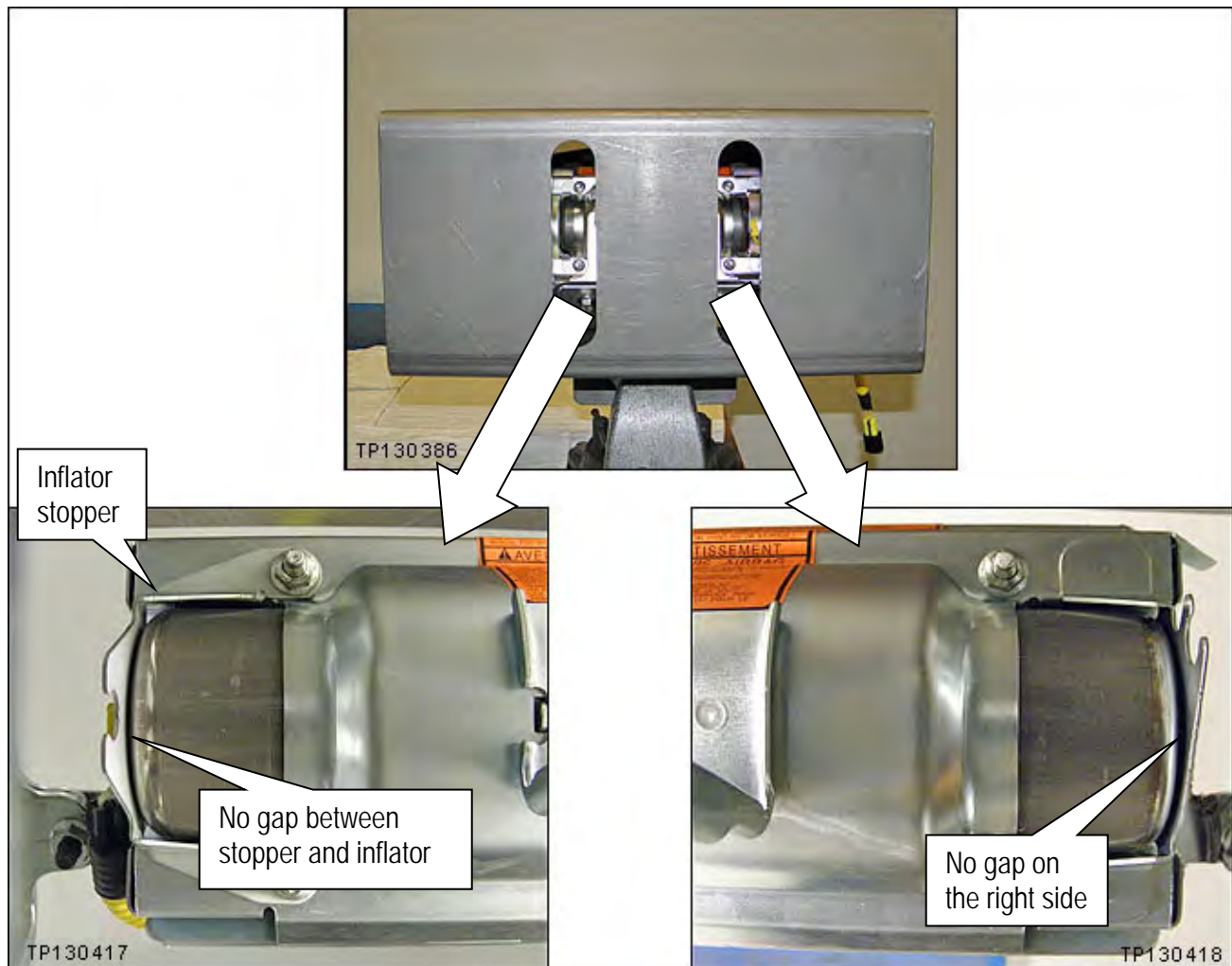

Figure M15

21. Torque the 4 inflator securing nuts.

- Torque nuts to:
3.9 N•m (0.39 kg-m, 34 in-lb.).
- Torque in the order shown.

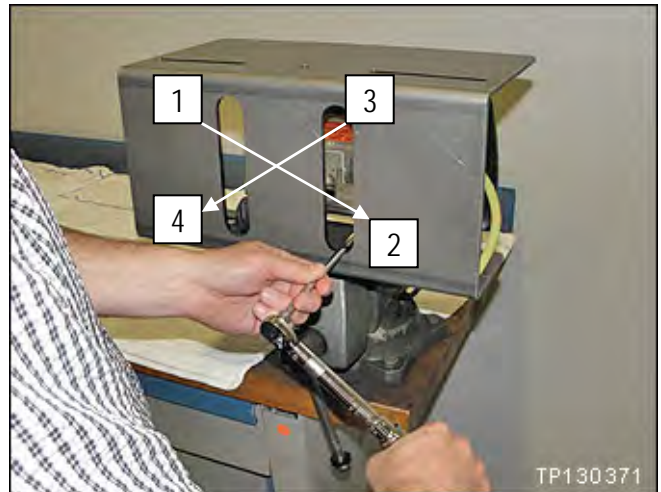
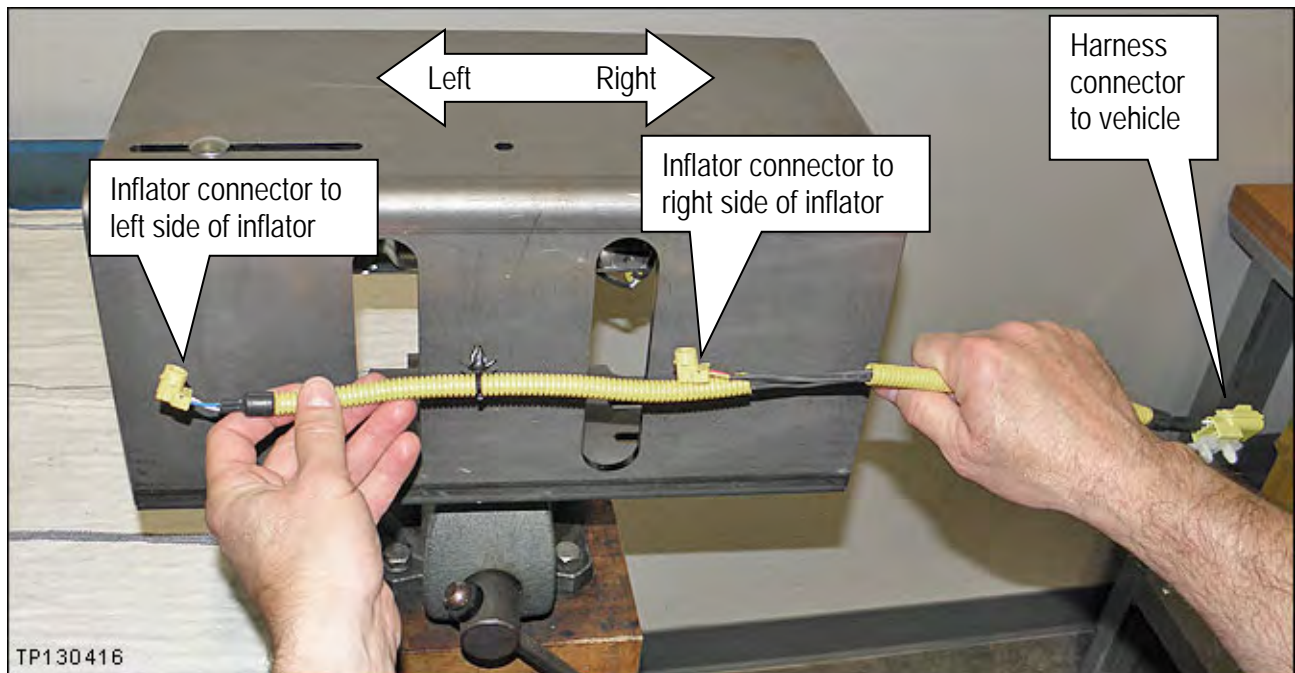

Figure M16

IMPORTANT:

- In the next step you will be attaching the new harness to the new inflator.
- Once the inflator connector is attached to the inflator, it cannot be disconnected.
- **Make sure to attach the connectors to the correct ends of the inflator (see M17).**
 - Left / Right orientation is as shown in Figure M17.



M17

22. Attach the new harness to each end of the inflator.

- Remove the dust proof stickers covering the ends of the inflator.
- A new harness is included with the new inflator.
- Make sure to attach the correct ends (see Figure M17 on the previous page).
- Refer to Figures M17, M18, M19, and M20.



Figure M18

- Make sure the T shape at the inflator end aligns with the T shape of the connector.

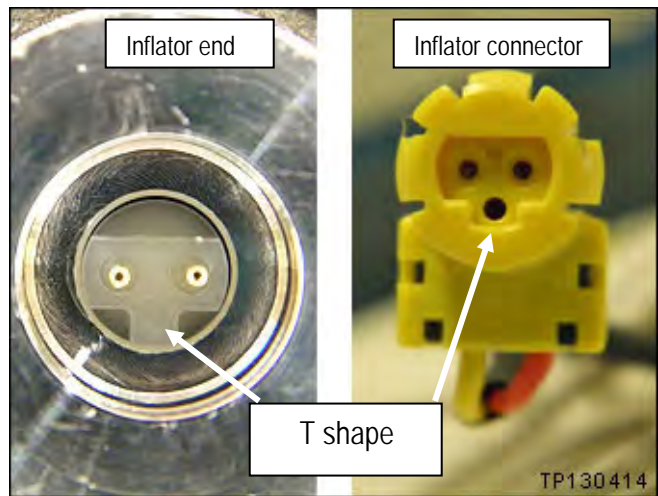

Figure M19

- Make sure the harness connector is fully engaged / seated (see Figure M20).

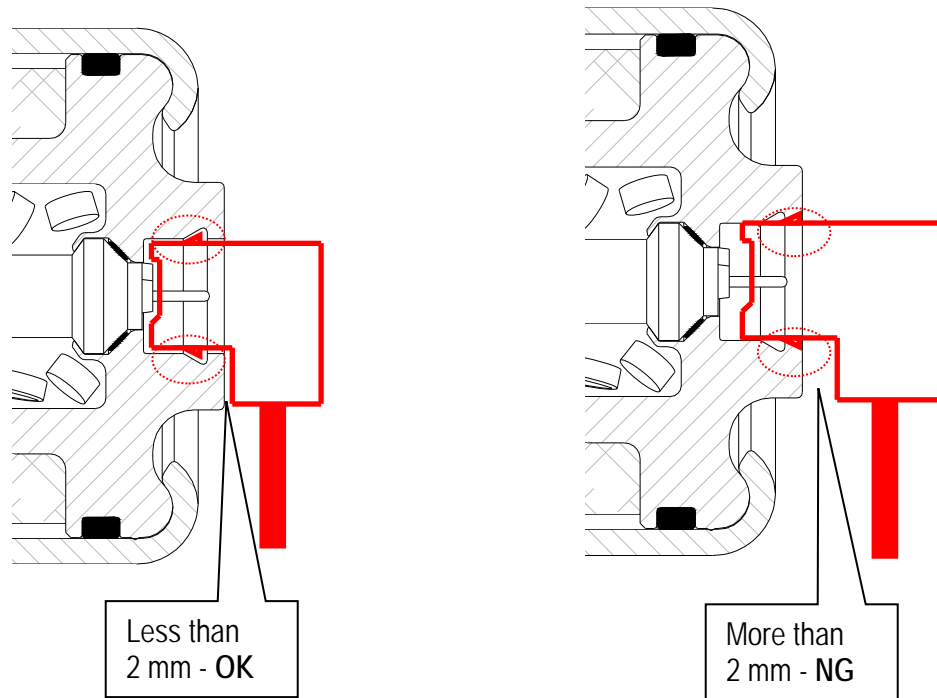

Figure M20

23. Remove the module from the support and set it on the clean working area.

24. Remove the support bracket from the module frame.

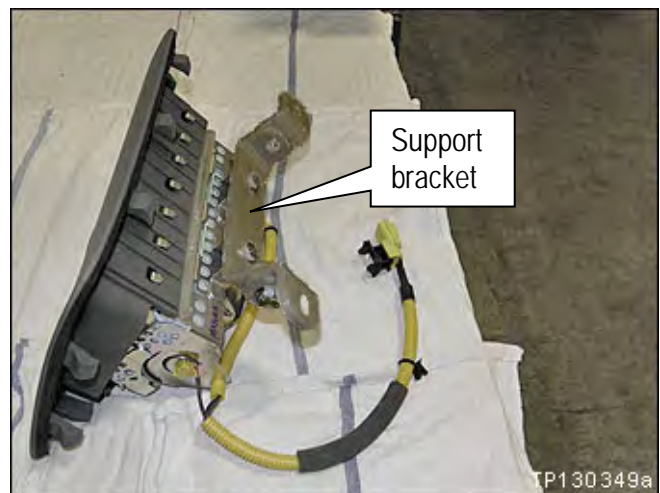

Figure M21

25. Attach the harness clip to the module frame.

26. Route/attach the harness to the harness guides.

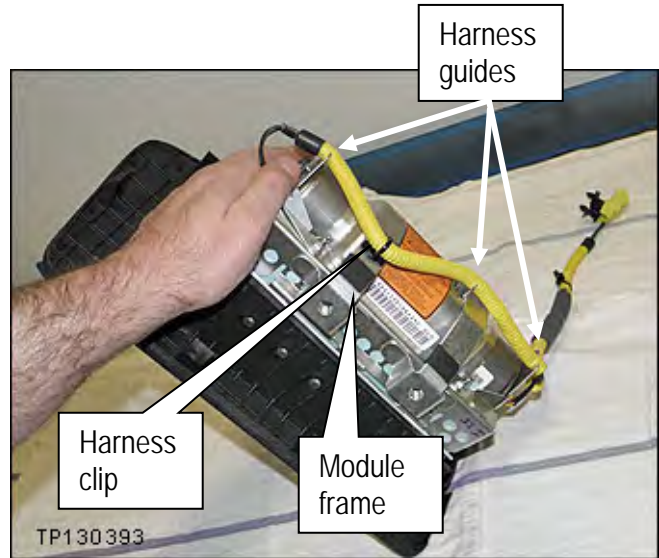

Figure M22

NOTE:

- Make sure to return the removed (old / non-deployed) inflator in the box that the new inflator came in.
- Follow the return instructions provided by Takata.
- Return instructions provided by Takata are attached to this bulletin on page 39.

FX Inflator replacement

WARNING: Wear safety glasses while performing inflator replacement.

1. Set the module on a clean working area.
2. Disconnect the harness clip from the module frame.

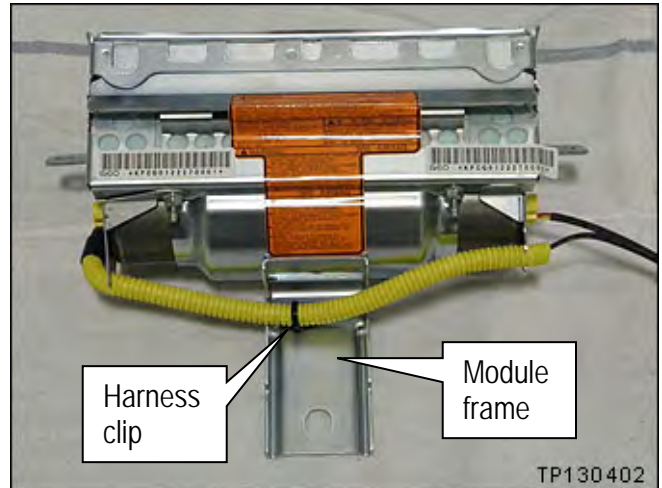

Figure F1

3. Attach the FX brackets to the support as shown.
 - Make sure the convex parts of the brackets are in the UP position.
 - Use bolts and nuts supplied with the support.
 - Leave the bolts/nuts slightly loose to allow for positioning of the module.

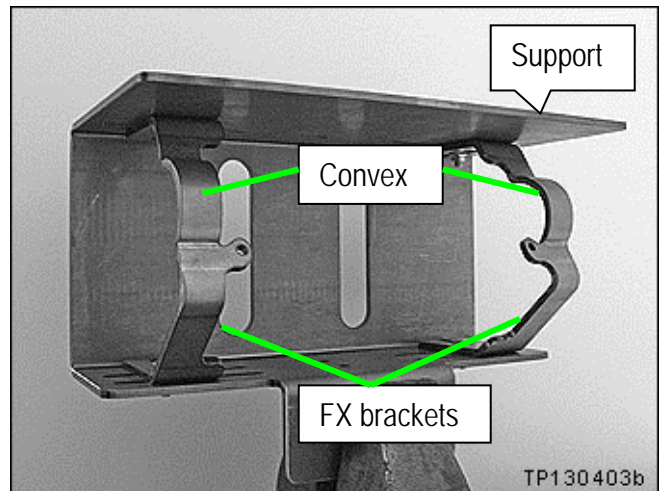

Figure F2

4. Attach the module to the FX brackets in the support as shown.
 - Use bolts and nuts supplied with the support.
 - Make sure the arrow on the bag is pointing up.

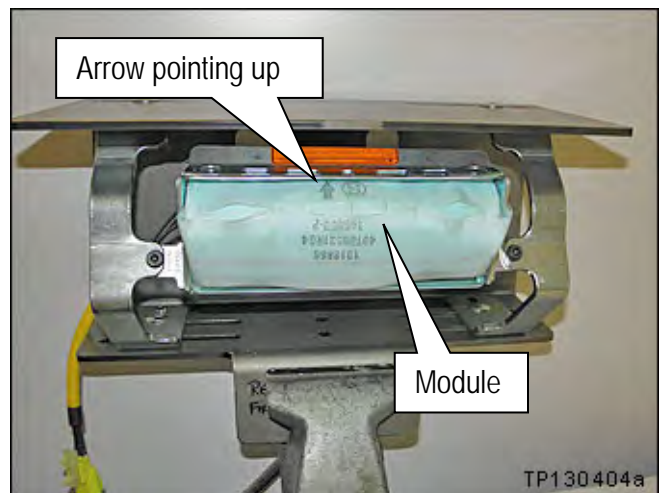

Figure F3

5. Make sure the module is centered in the support.

NOTE: Centering the module in the support will allow access to the inflator securing nuts through the slots in the support.

6. Tighten all of the mounting bolts and nuts that hold the module and brackets to the support.

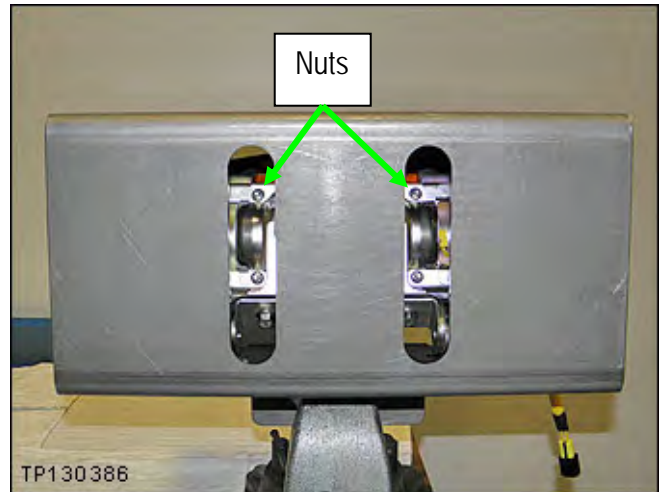

Figure F4

WARNING: Work from behind and to the sides of the support.

7. Carefully cut a few inches of the yellow corrugated harness cover in the area shown.

- Do not cut the wires inside the corrugated cover.

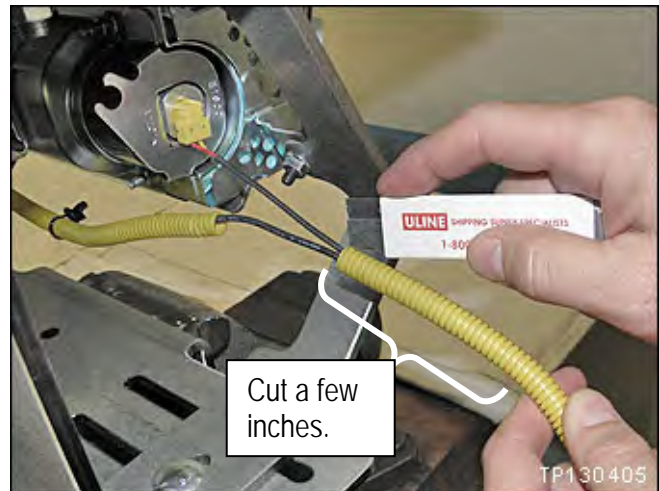

Figure F5

8. Attach 2 shorting pins to the inflator harness as shown.

- Make sure to pair the wires from each end of the inflator.

Blue with White

Red with Yellow

- Use an insulation displacement type wire connector as a shorting pin.
- Refer to the Parts Information for additional connector/shorting pin information.

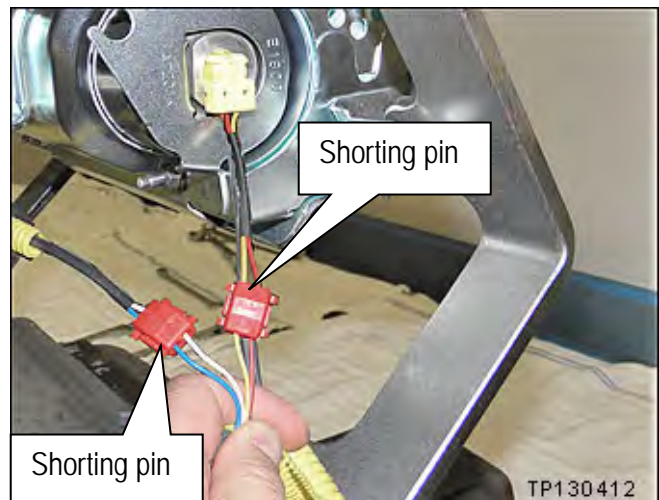

Figure F6

9. Cut off the connector end of the harness.



Figure F7

10. Remove the 4 nuts from the module that hold the inflator in place (see Figures F8 and F9).

- Use a ratchet and extension.



Figure F8

- Remove the 4 nuts.

NOTE: These nuts will not be reused.

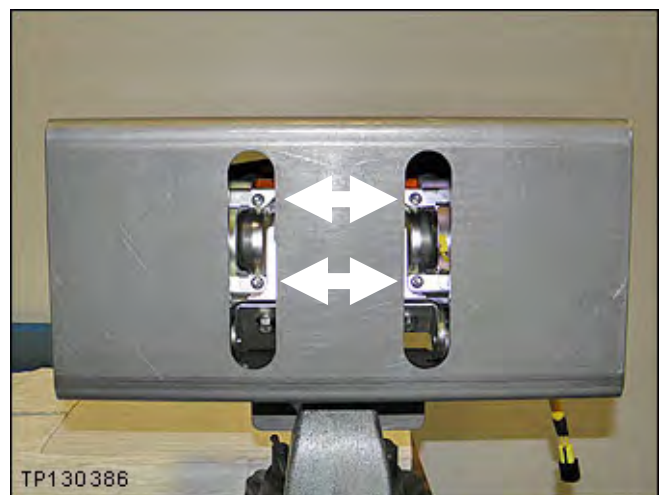

Figure F9

11. Remove the inflator stopper.

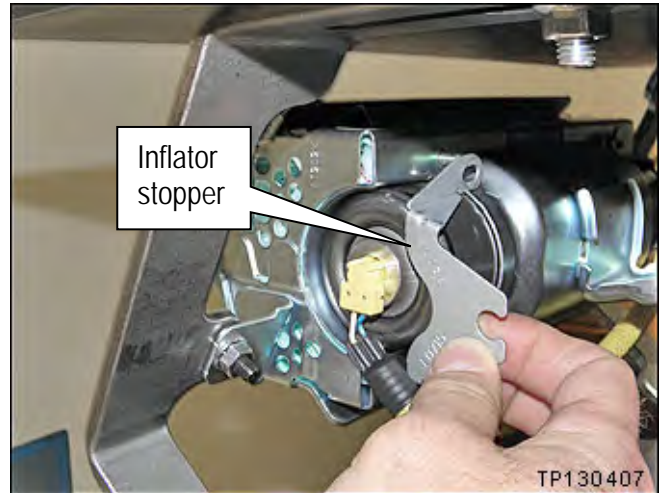

Figure F10

12. Push the right side of the inflator out of the module.

- Twist the inflator to a position that will allow the connector and harness to fit through the opening.



Figure F11

13. Pull the inflator completely out of the module from the left side.



Figure F12

14. Set the old inflator in the clean working area and make sure it does not roll and fall to the floor.

NOTE:

- Follow the return instructions provided by Takata.
- Return instructions provided by Takata are attached to this bulletin on page 39.

15. Remove the new inflator from the box.

16. Slide the new inflator into the module from the left side.



Figure F13

17. Make sure the inflator is positioned / oriented correctly as shown.

- The flat side of the inflator end (on the right side) must align with the flat side of the inflator housing.

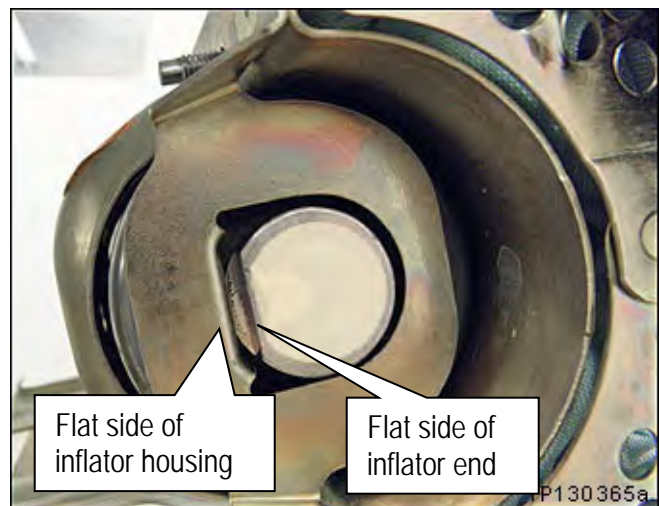

Figure F14

18. Install the inflator stopper and 4 inflator securing nuts finger tight (see Figure F15).

- Make sure to use **new nuts**.
- New nuts are included with the new inflator.

19. Make sure the inflator is pushed all the way into its housing – no gap on the right side (see Figure F15).

20. Make sure there is no gap between the inflator stopper and the inflator on the left side (see Figure F15).

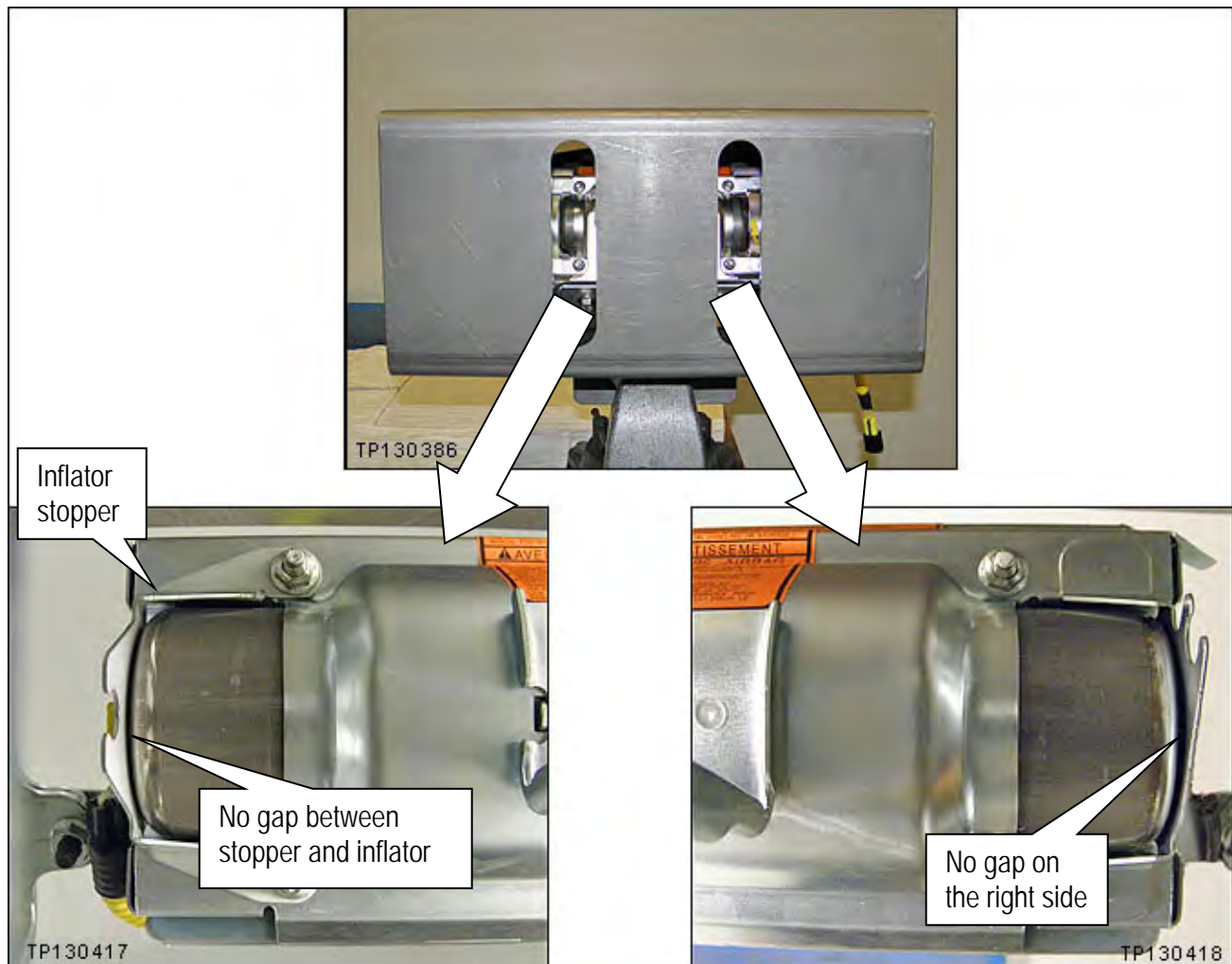

Figure F15

21. Torque the 4 inflator securing nuts.

- Torque nuts to:
3.9 N•m (0.39 kg-m, 34 in-lb.).
- Torque in the order shown.

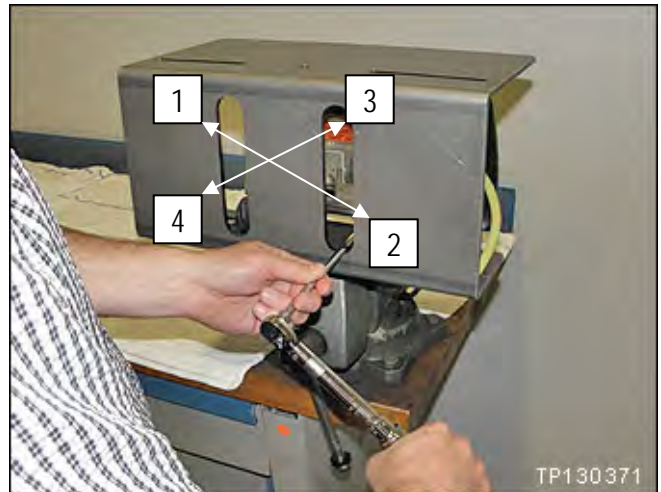

Figure F16

IMPORTANT:

- In the next step you will be attaching the new harness to the new inflator.
- Once the inflator connector is attached to the inflator, it cannot be disconnected.
- Make sure to attach the connectors to the correct ends of the inflator (see F17).
 - Left / Right orientation is as shown in Figure F17.

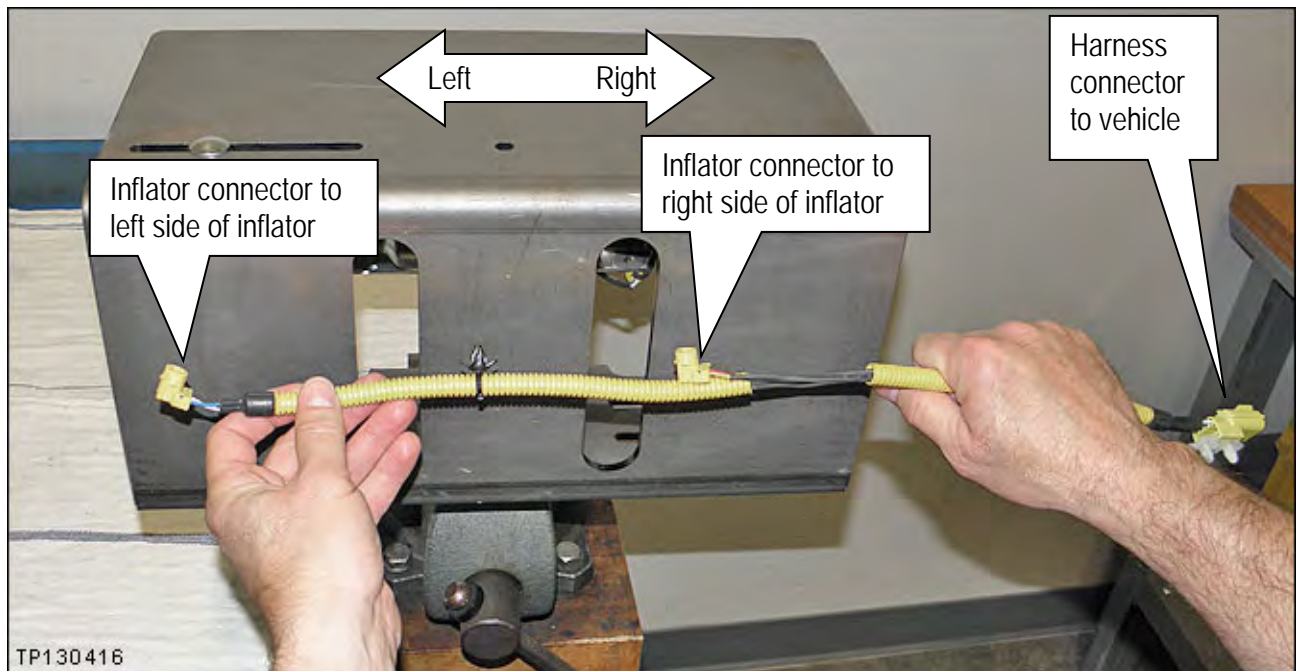

Figure F17

22. Attach the new harness to each end of the inflator.

- Remove the dust proof stickers covering the ends of the inflator.
- A new harness is included with the new inflator.
- Make sure to attach the correct ends (see Figure F17 on the previous page).
- Refer to Figures F17, F18, F19, and F20.



Figure F18

- Make sure the T shape at the inflator end aligns with the T shape of the connector.

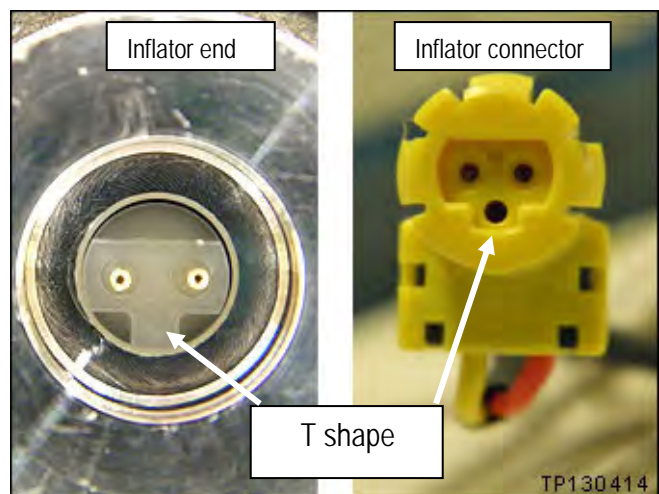

Figure F19

- Make sure harness connector is fully engaged / seated (see Figure F20).

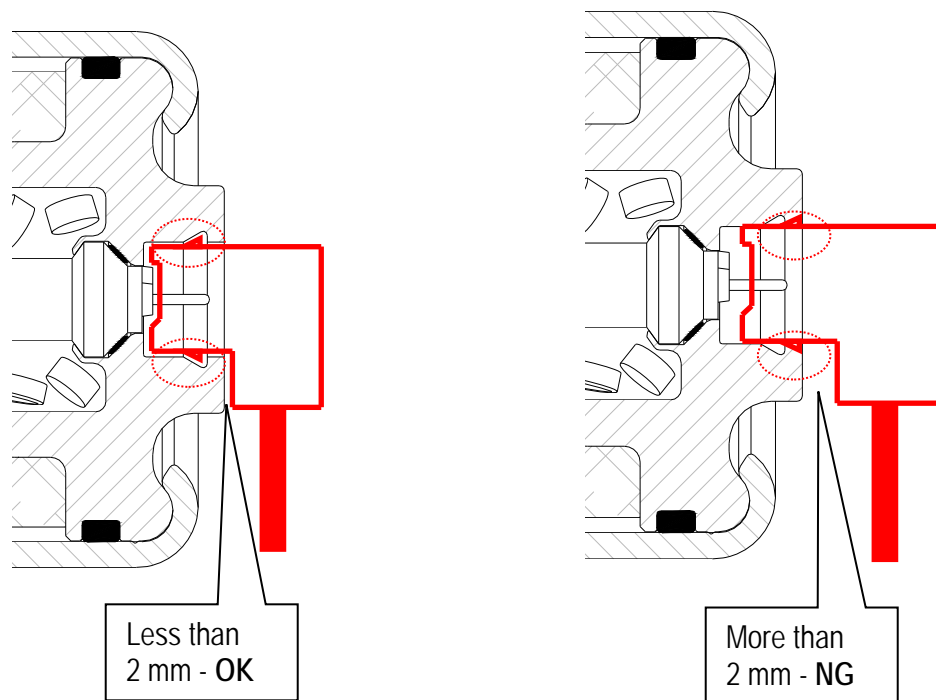

Figure F20

23. Remove the module from the support and set it on the clean working area.

24. Attach the harness clip to the module frame.

25. Clip the harness into the harness guides.

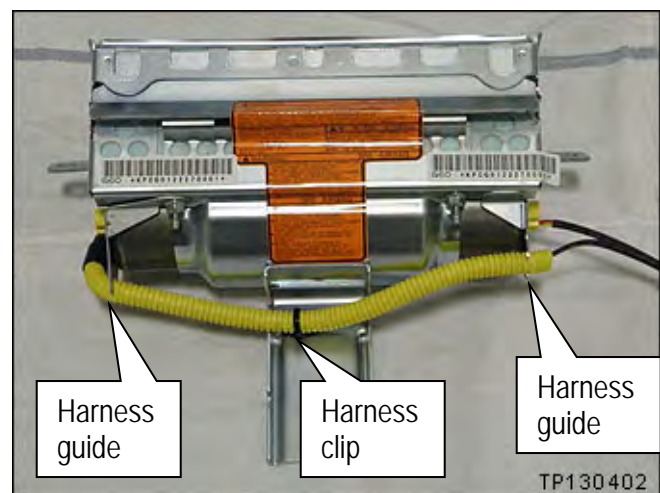

Figure F21

NOTE:

- Make sure to return the removed (old / non-deployed) inflator in the box that the new inflator came in.
- Follow the return instructions provided by Takata.
- Return instructions provided by Takata are attached to this bulletin on page 39.

M Inflator replacement

IMPORTANT: Connection of the new harness for the M is different than the I35 or FX. Make sure to read the harness connection instructions.

WARNING: Wear safety glasses while performing inflator replacement.

1. Set the module on a clean working area.
2. Unclip the harness from the harness guides.



Figure Y1

3. Attach the FX brackets to the support as shown.
 - Make sure the convex parts of the brackets are in the UP position.
 - Use bolts and nuts supplied with the support.
 - Leave the bolts/nuts slightly loose to allow for positioning of the module.

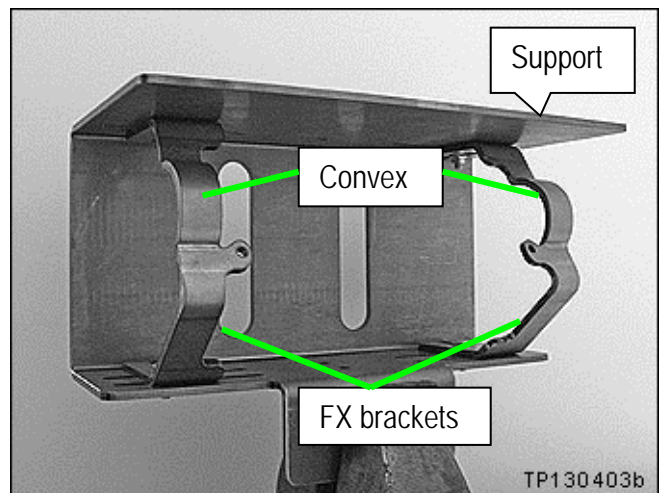

Figure Y2

4. Attach the module to the FX brackets in the support as shown.
 - Use bolts and nuts supplied with the support.
 - Make sure the arrow on the bag is pointing down.

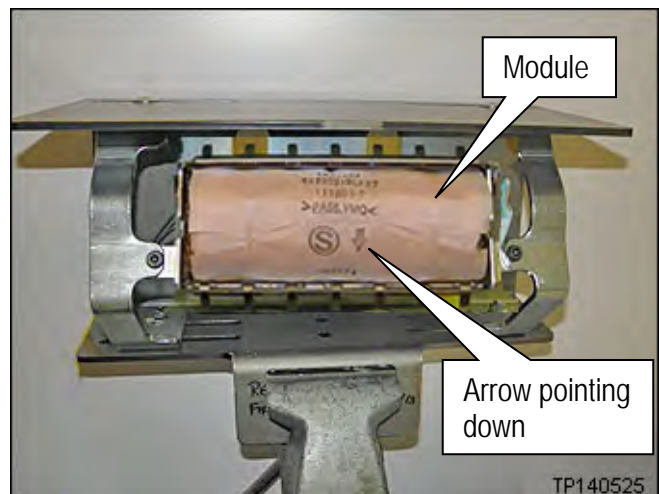

Figure Y3

5. Make sure the module is centered in the support.

NOTE: Centering the module in the support will allow access to the inflator securing nuts through the slots in the support.

6. Tighten all of the mounting bolts and nuts that hold the module and brackets to the support.

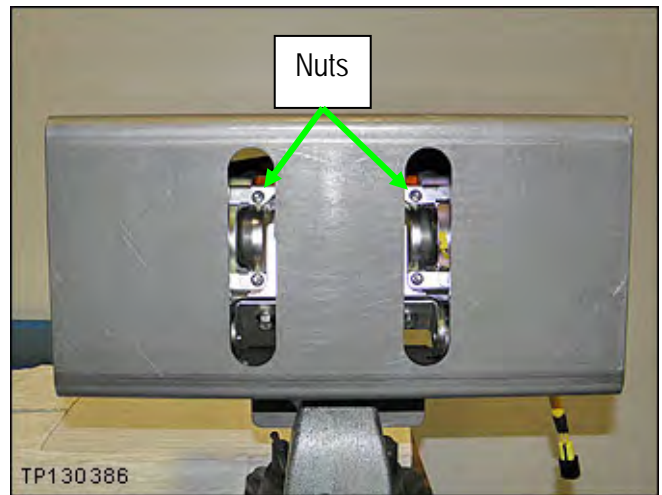

Figure Y4

WARNING: Work from behind and to the sides of the support.

7. Carefully cut a few inches of the yellow corrugated harness cover in the area shown.

- Do not cut the wires inside the corrugated cover.

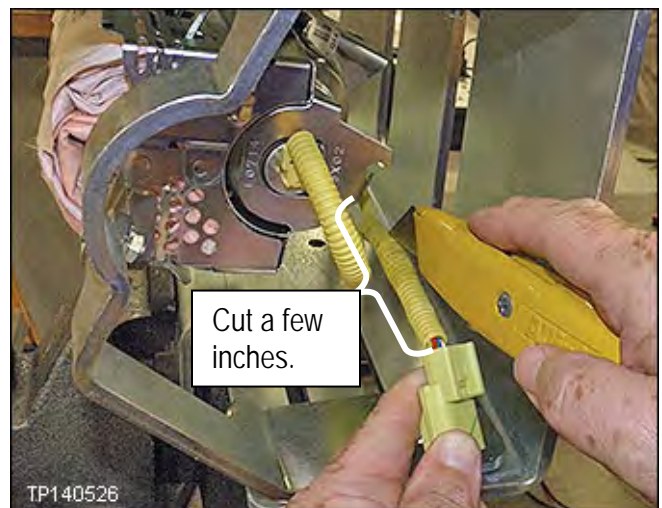

Figure Y5

8. Attach 2 shorting pins to the inflator harness as shown.

- Make sure to pair the wires from each end of the inflator.

Blue with White

Red with Yellow

- Use an insulation displacement type wire connector as a shorting pin.
- Refer to the Parts Information for additional connector/shorting pin information.

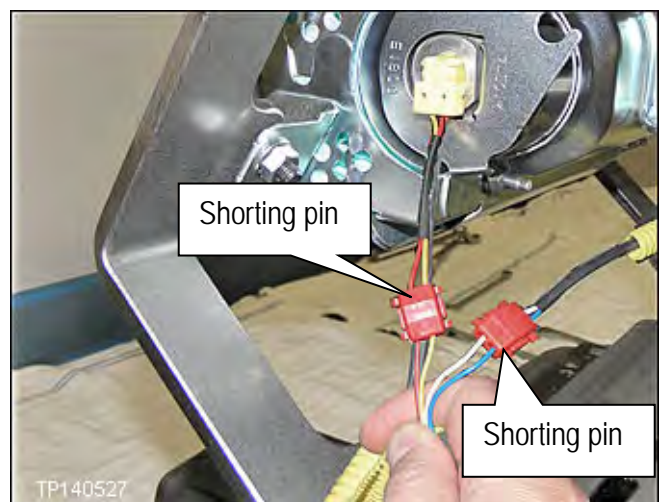

Figure Y6

9. Cut off the connector end of the harness.



Figure Y7

10. Remove the 4 nuts from the module that hold the inflator in place (see Figures Y8 and Y9).

- Use a ratchet and extension.



Figure Y8

- Remove the 4 nuts.

NOTE: These nuts will not be reused.

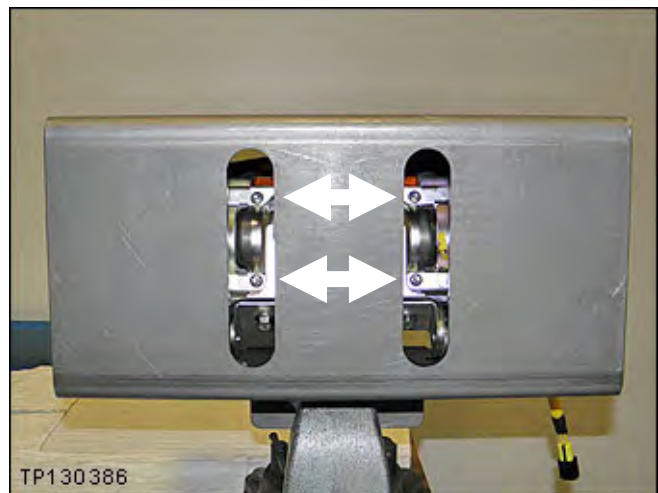

Figure Y9

11. Remove the inflator stopper.

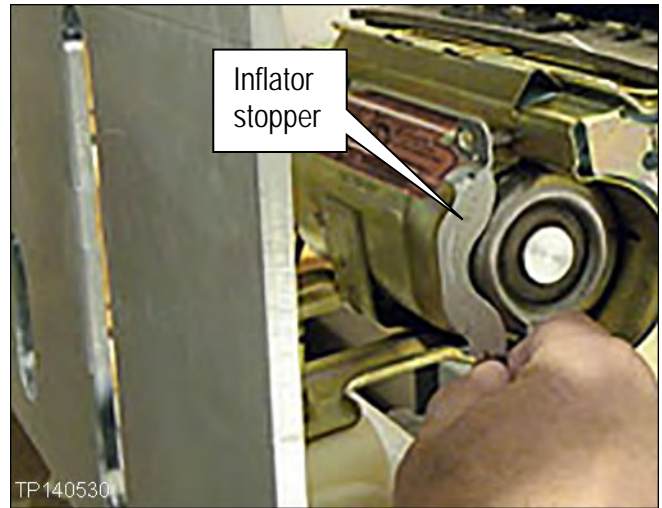

Figure Y10

12. Push the left side of the inflator out of the module.

- Twist the inflator to a position that will allow the connector and harness to fit through the opening.

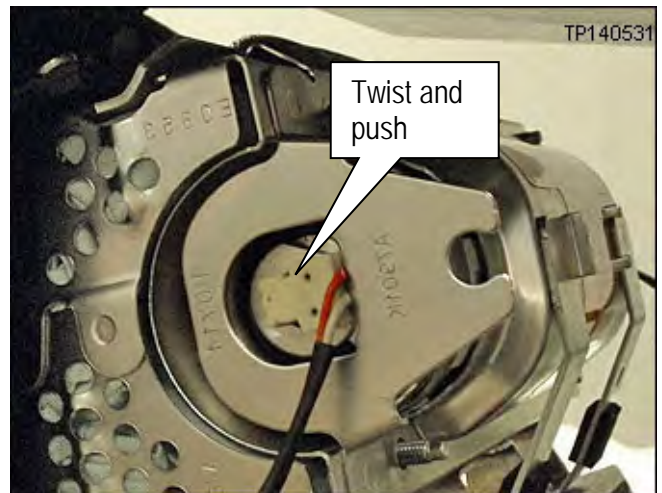

Figure Y11

13. Pull the inflator completely out of the module from the right side.

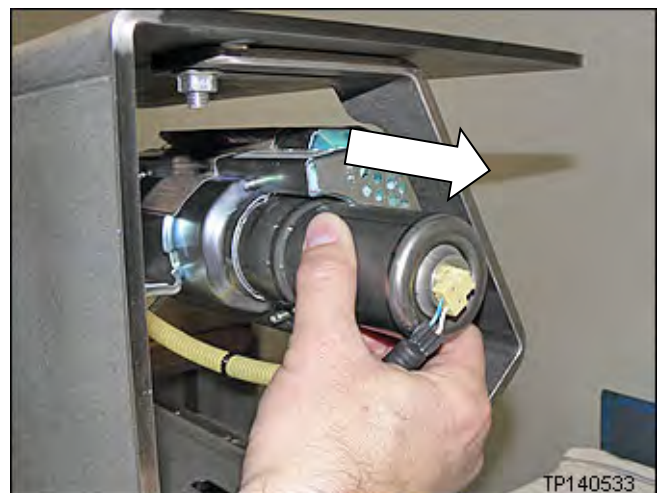

Figure Y12

14. Set the old inflator in the clean working area and make sure it does not roll and fall to the floor.

NOTE:

- Follow the return instructions provided by Takata.
- Return instructions provided by Takata are attached to this bulletin on page 39.

15. Remove the new inflator from the box.

16. Slide the new inflator into the module from the right side.



Figure Y13

17. Make sure the inflator is positioned / oriented correctly as shown.

- The flat side of the inflator end (on the left side) must align with the flat side of the inflator housing.

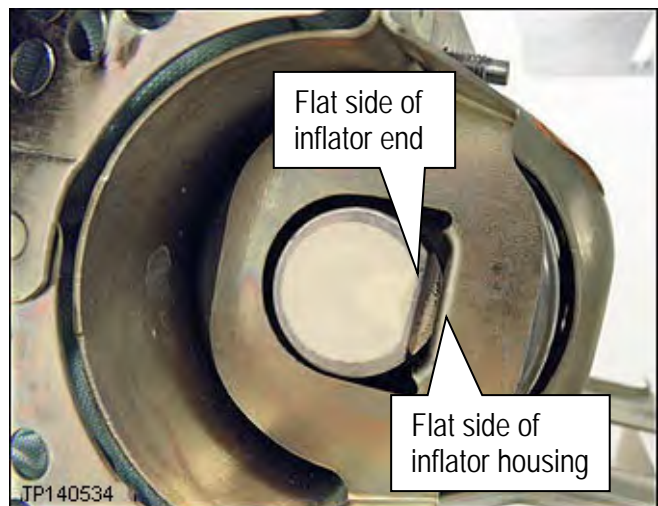

Figure Y14

18. Install the inflator stopper and 4 inflator securing nuts finger tight (see Figure Y15).

- Make sure to **use new nuts**.
- New nuts are included with the new inflator.

19. Make sure the inflator is pushed all the way into its housing – no gap on the left side (see Figure Y15).

20. Make sure there is no gap between the inflator stopper and the inflator on the right side (see Figure Y15).

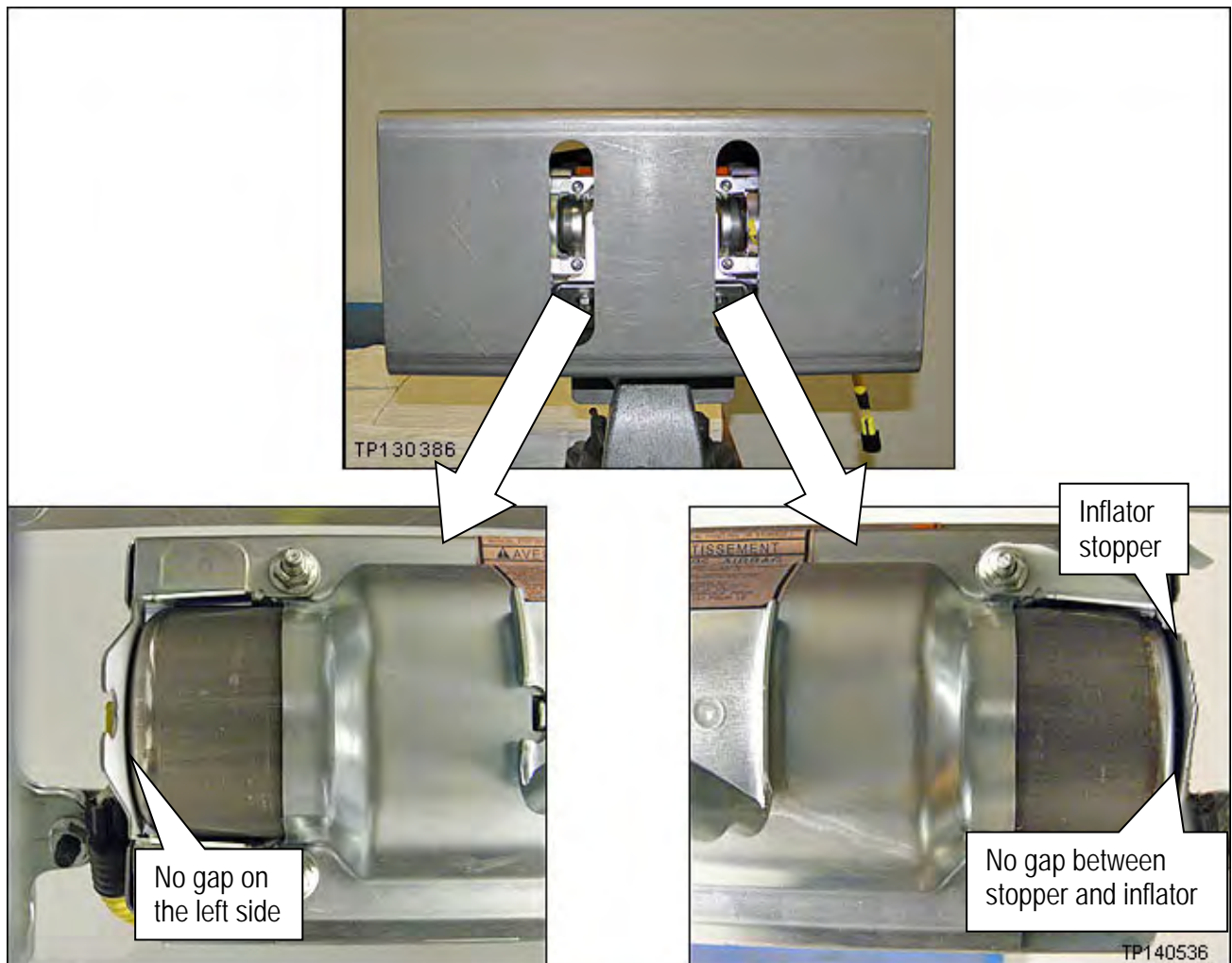

Figure Y15

21. Torque the 4 inflator securing nuts.

- Torque nuts to:
3.9 N•m (0.39 kg-m, 34 in-lb.).
- Torque in the order shown.

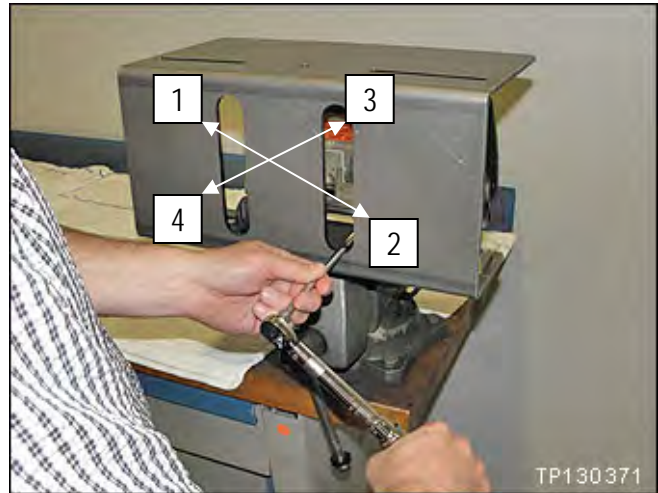

Figure Y16

IMPORTANT:

- In the next step, on the next page, you will be attaching the new harness to the new inflator.
- Once the inflator connector is attached to the inflator, it cannot be disconnected.
- Make sure to attach the connectors to the correct ends of the inflator (see Figure Y17).

22. Attach the new harness to each end of the inflator.

- Remove the dust proof stickers covering the ends of the inflator.
- Refer to Figures Y17, Y18, and Y19.

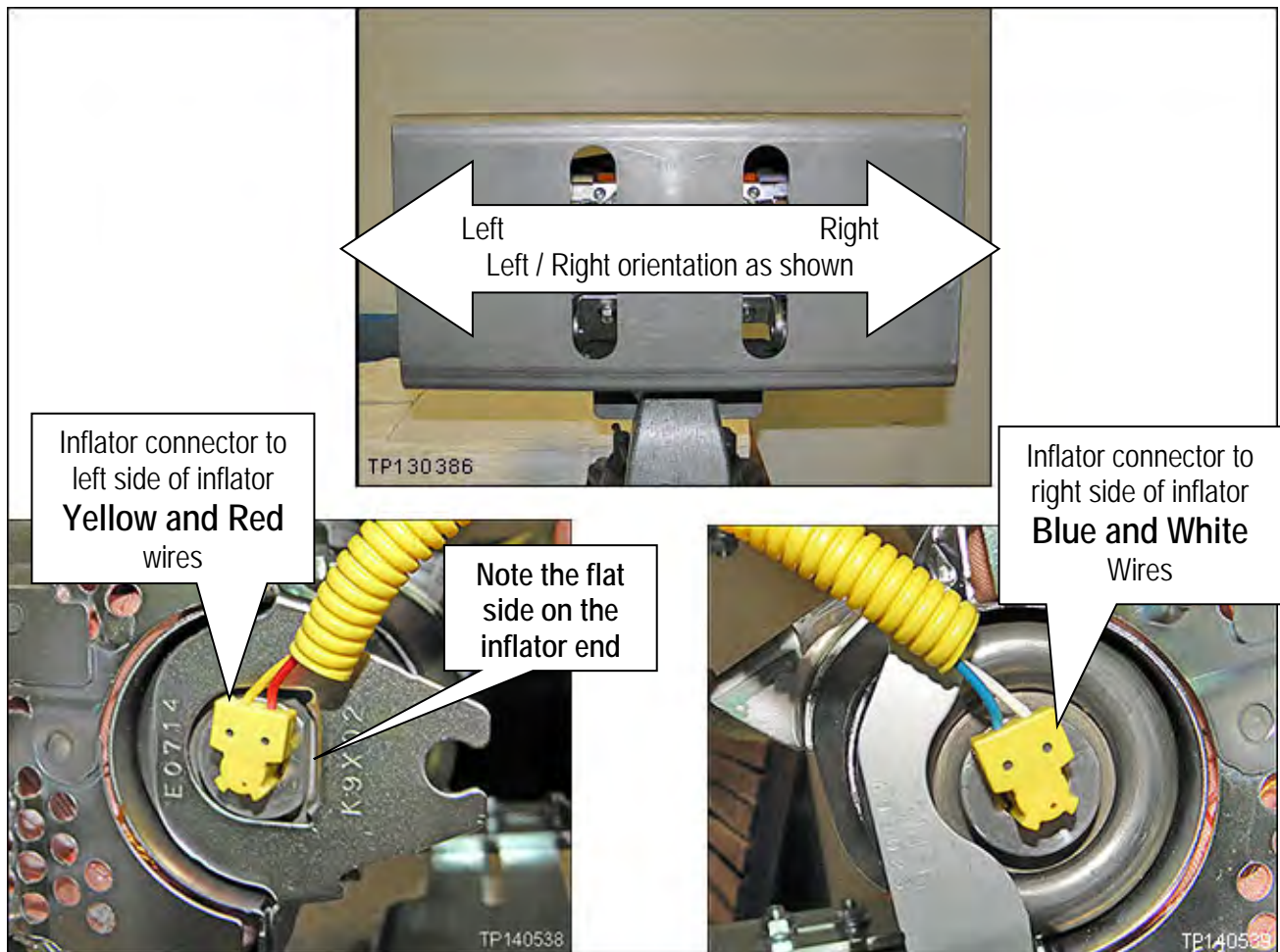

Figure Y17

- Make sure the T shape at the inflator end aligns with the T shape of the connector.

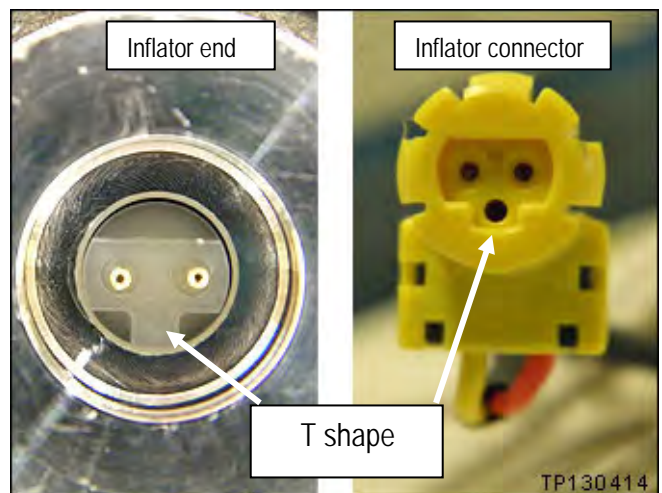

Figure Y18

- Make sure harness connector is fully engaged / seated (see Figure Y19).

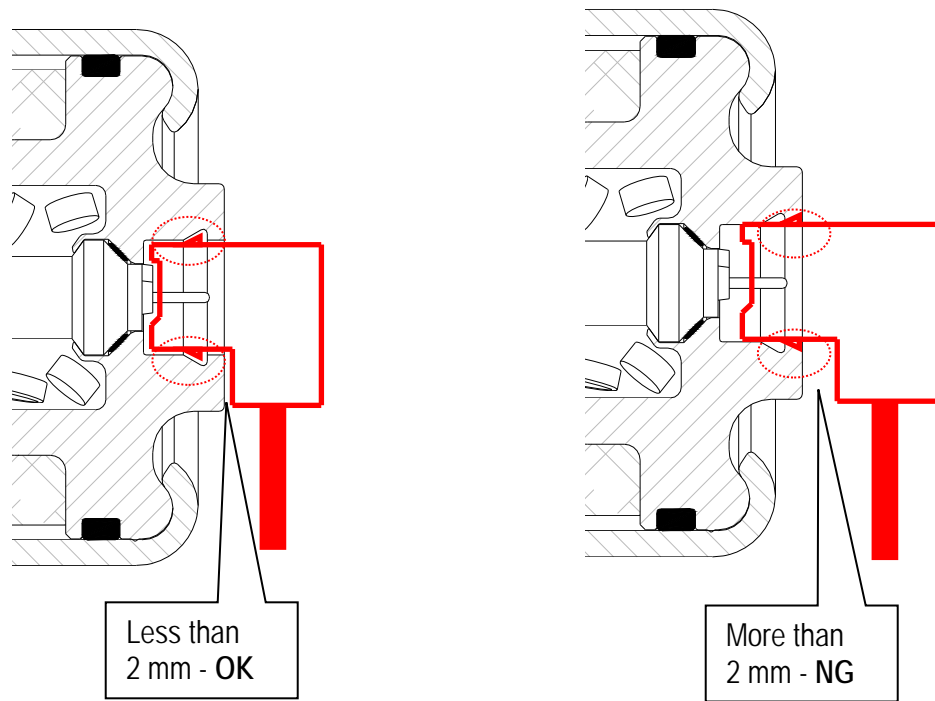

Figure Y19

23. Remove the module from the support and set it on the clean working area.

24. Clip the harness into the harness guides.

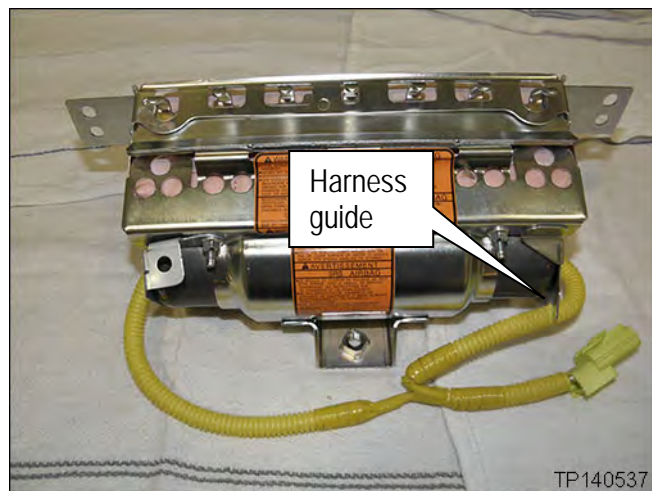



Figure Y20

NOTE:

- Make sure to return the removed (old / non-deployed) inflator in the box that the new inflator came in.
- Follow the return instructions provided by Takata.
- Return instructions provided by Takata are attached to this bulletin on page 39.

PARTS INFORMATION

Model and Year	Description	PART #	Quantity
2003-2004 I35	INFLATOR-AIR BAG ASST	K8561-7999B	1
2003-2005 FX35/45			
2006 M			
2003-2004 I35	HARNESS KIT (Includes inflator, module mounting bolts, and inflator securing nuts)	B4167-2Y00A	1
2003-2005 FX35/45		B4A67-CG00A	1
2006 M		B4A67-EH50C	1
<p align="center">Shorting Pin (Insulation Displacement Connector for 22-18 gauge wire)</p> 		<p>NAPA item # 784566</p> <p>Grainger Item # 4YT50</p> <p>or equivalent available from local auto supply</p>	2

NOTE:

- Make sure to return the removed (old / non-deployed) inflator in the box that the new inflator came in.
- Follow the return instructions provided by Takata.
- Return instructions provided by Takata are attached to this bulletin on page 39.

CLAIMS INFORMATION

Submit a "CM" line claim using the following claims coding:

CAMPAIGN ("CM") I.D.	DESCRIPTION	OP CODE	FRT
R1706	I35 - Remove and replace front passenger air bag inflator	R17060	0.8 hrs.

OR

CAMPAIGN ("CM") I.D.	DESCRIPTION	OP CODE	FRT
R1706	FX - Remove and replace front passenger air bag inflator	R17061	1.1 hrs.

OR

CAMPAIGN ("CM") I.D.	DESCRIPTION	OP CODE	FRT
R1706	M - Remove and replace front passenger air bag inflator	R17064	2.7 hrs.

EXPENSE CODE

CODE	DESCRIPTION	MAXIMUM AMOUNT
041	Shorting Pin (Insulation Displacement Connector for 22-18 gauge wire)	\$0.50



Takata Document

NOTE

NOTE: International (including Mexico and Canada), Hawaii, Alaska, Puerto Rico, and US Virgin Islands dealers **CANNOT** follow below shipping instructions. Instead, dealerships in these locations **MUST** contact the following Takata/Merilo USA representative directly for shipping instructions: Miguel Prigadaa – Tel #: 210-250-5078 or Email: MLGTakataRestrains_International@XPO.com

NOTE: For Continental US 48 State dealerships, please follow steps 1-8 below.

- Specific to Step 4 below:
 - Follow step 4a if you receive the updated NON-FedEx Label. Proceed to step 5.
 - Follow step 4b if you receive the FedEx Label. Proceed to step 5.

1. Shipping Documents

a) Box Label

- Supplied with each Kit
- To be affixed to each box



b) Over-pack Label

- To be supplied by XPO.
- To be affixed to the outside of each pallet



c) Bill of Lading

- To be supplied by XPO.
- Print 2 copies: 1 for Dealer Records, 1 for LTL Driver



d) ERG Document

- To be supplied by XPO.
- To be provide by the Dealer to the LTL Driver for each shipment



5. Shipping Instructions – Prepare the Pallet

- a) Accumulate and palletize Kits
- b) Arrange Kits on Pallet as pictured here
 - 20 boxes per row/layer (5x4)
 - 10 rows/layers per pallet (200 boxes)
- c) Shrink-wrap Kits to Pallet
- d) Affix Over-pack Label on (1) side of Pallet (Not on Top)



6. Shipping Instructions – Schedule LTL Pickup

- a) Upon Accumulating 200 kits (1 Over-pack/Pallet) Minimum
 - Call XPO at 1-210-250-5079
 - If 200 Kits have not been accumulated in 30 days, please call XPO for direction
- c) Have the following information Available
 - Dealer #
 - Quantity of Over-packs/Pallets
 - Quantity of Passenger Inflator Kits on each Pallet
 - Email Address where shipping Documentation can be received

2. Packing Instructions

a) Confirm box is in acceptable condition. If a new box is needed, follow the New Box instructions located in Box 8 of this page.

b) Place the un-deployed air bag inflator in the "cradle" of the box insert.



3. Closure Instructions

a) Close the top box flap, per box closure instructions located on front panel of box.



7. Shipping Instructions – Ship

- a) Give 1 Copy of BOL and 1 Copy of ERG to Driver
- b) Retain 1 Copy of BOL for Dealership records and archive for 2 Years

8. Requesting a New Box / Shipping Labels

If a new box or replacement shipping labels are needed, please contact the representative listed below by phone or email to request replacement materials.

Primary Contact: Armando Gonzalez - Tel #: 210-250-5079

E-Mail: SCFieldaction.14305@xpo.com

To help expedite your request, please be prepared to provide the following information:

- a) Serial number on the original box.
- b) What Type of shipping material needed
 - Replacement Box
 - Two Part Return Label
 - Bill of Lading
 - ERG Form
- c) Dealer Shipping Information
 - Contact name
 - Dealer Address
 - Phone Number



4a. Shipping Instructions – Label each Box

a) New Labels will begin shipping in each kit starting mid June, 2015

