

Classification:
RS17-028d**Reference:**
ITB17-024d**Date:**
January 15, 2020

VOLUNTARY SAFETY RECALL CAMPAIGN 2006-2007 M; FRONT PASSENGER AIR BAG INFLATOR

**This bulletin has been amended. See AMENDMENT HISTORY on page 32.
Please discard previous versions of this bulletin.**

CAMPAIGN ID #s: R1622, R1701, R1704, R1706, R1707**NHTSA #s:** 15V-226, 16V-349, 17V-028**APPLIED VEHICLES:** 2006-2007 M (Y50)

**Check Service COMM or Dealer Business Systems (DBS)
National Service History to confirm campaign eligibility.**

INTRODUCTION

Infiniti is conducting a Voluntary Safety Recall Campaign on certain specific model year 2006-2007 M vehicles to replace the passenger front air bag module and inflator. This service will be performed at no charge to the customer for parts or labor.

Takata has issued return packaging, shipping labels, documents, and directions that must be used and followed in order to properly carry out this campaign. Takata's documentation is attached and is part of this bulletin.

IDENTIFICATION NUMBER

Infiniti has assigned identification numbers R1622, R1701, R1704, R1706, and R1707 to this campaign. Use Service COMM and the VIN to confirm the correct campaign ID number. The correct number must appear on all communication and documentation of any nature dealing with this campaign.

RETAILER RESPONSIBILITY

It is the retailer's responsibility to check Service COMM or Dealer Business Systems (DBS) National Service History for the campaign status on each vehicle falling within the range of this voluntary safety recall which for any reason enters the service department. This includes vehicles purchased from private parties or presented by transient (tourist) owners and vehicles in a retailer's inventory. Federal law requires that new vehicles in retailer inventory which are the subject of a safety recall must be corrected prior to sale. Failure to do so can result in civil penalties by the National Highway Traffic Safety Administration. While federal law applies only to new vehicles, Infiniti strongly encourages retailers to correct any used vehicles in their inventory before they are retailed.

Infiniti Bulletins are intended for use by qualified technicians, not 'do-it-yourselfers'. Qualified technicians are properly trained individuals who have the equipment, tools, safety instruction, and know-how to do a job properly and safely. NOTE: If you believe that a described condition may apply to a particular vehicle, DO NOT assume that it does. See your Infiniti retailer to determine if this applies to your vehicle.

1/33

REPAIR OVERVIEW

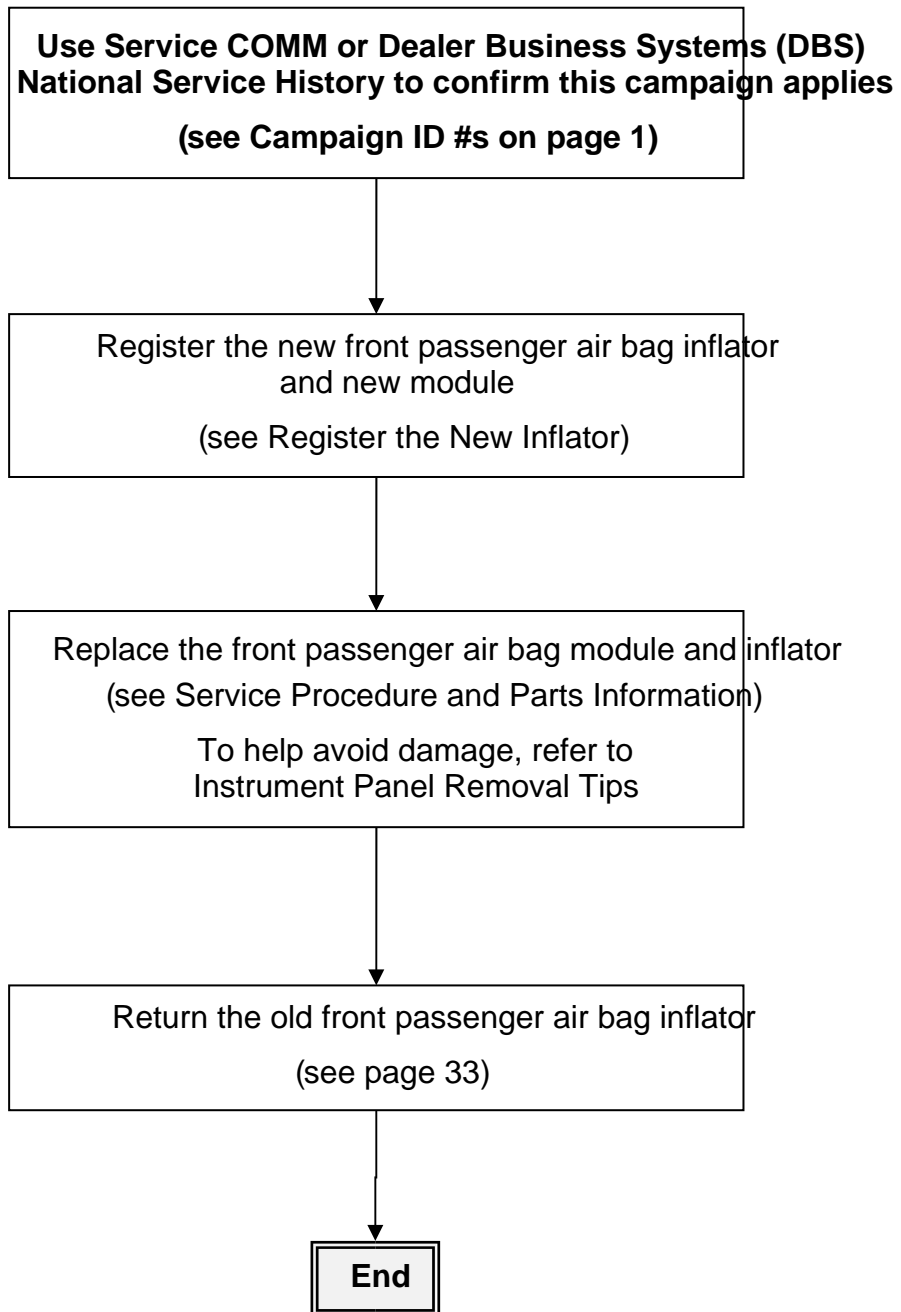

REQUIRED SPECIAL TOOLS

Air Bag Module Support (J-51315-KIT)

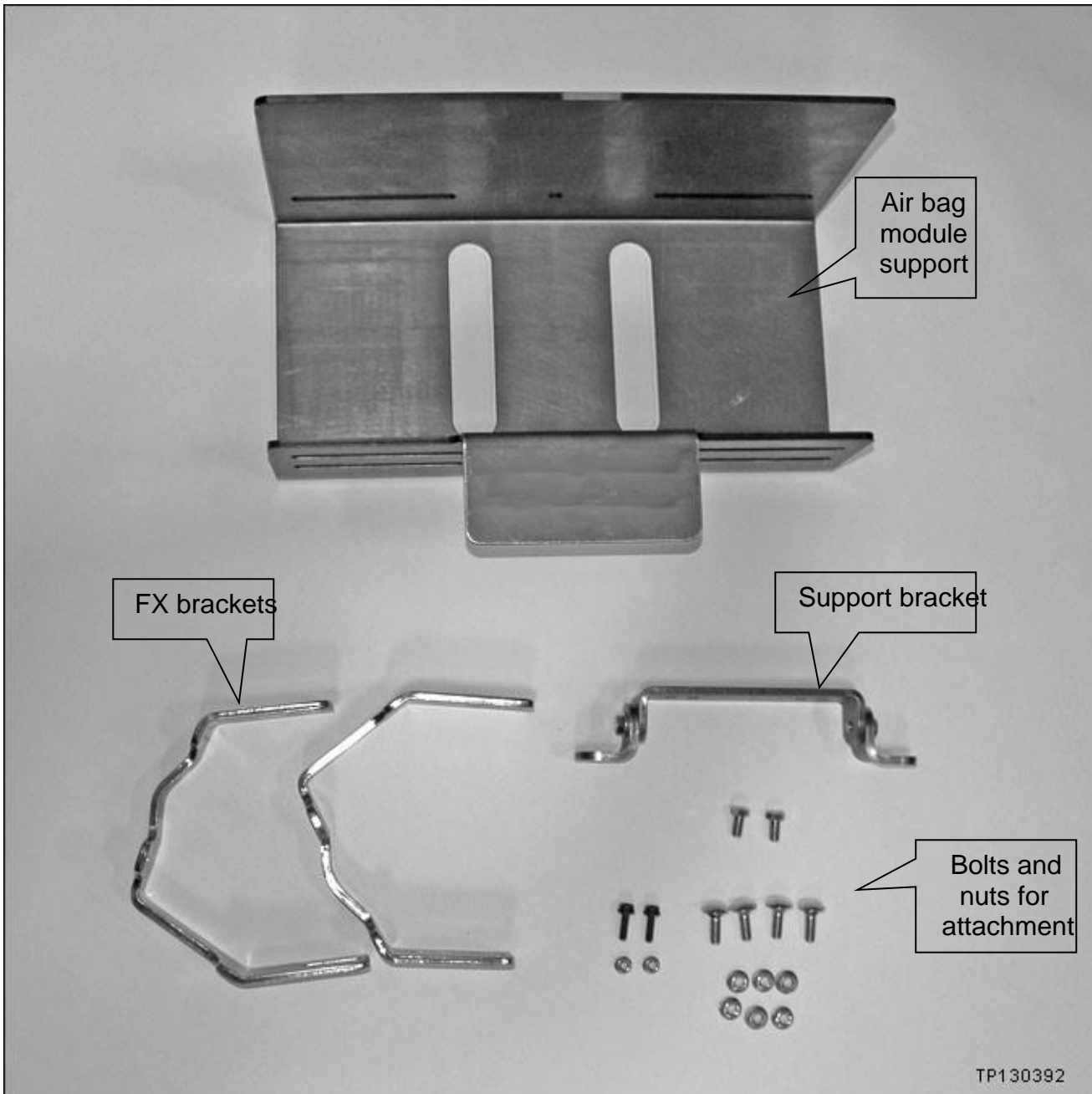

Figure A

REQUIRED SPECIAL TOOLS (continued)

Quick Scan Tool (J-52352)

- Each retailer has been shipped one Quick Scan Tool (J-52352).
- Additional tools can be obtained from Tech•Mate: nissantechmate.com or 1-800-662-2001.



Figure B

SERVICE PROCEDURE

Register the New Inflator and the New Module

1. Obtain a new inflator and a new module kit from your parts department.
 - New inflator and new module kit are listed in the Parts Information.

2. Attach the quick scan tool (J-52352) to your CONSULT PC USB port.

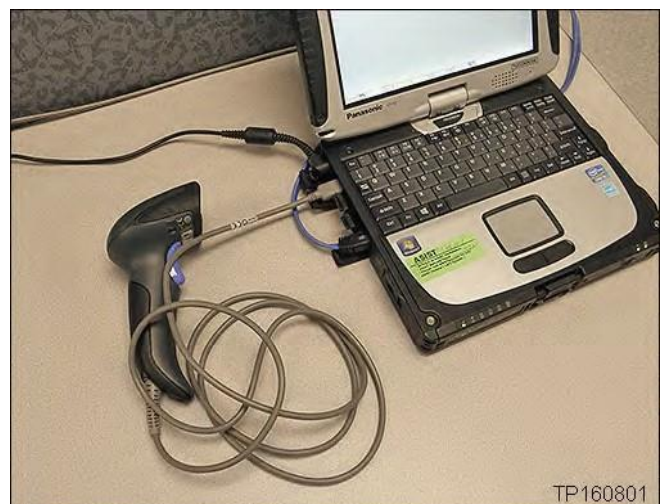

Figure 1

3. On the left side of the ASIST main menu, select **Tech Support Info**, then **Inventory Vehicle Actions**.



Figure 2

4. Select **CLICK HERE** (Air Bag to VIN Registration).

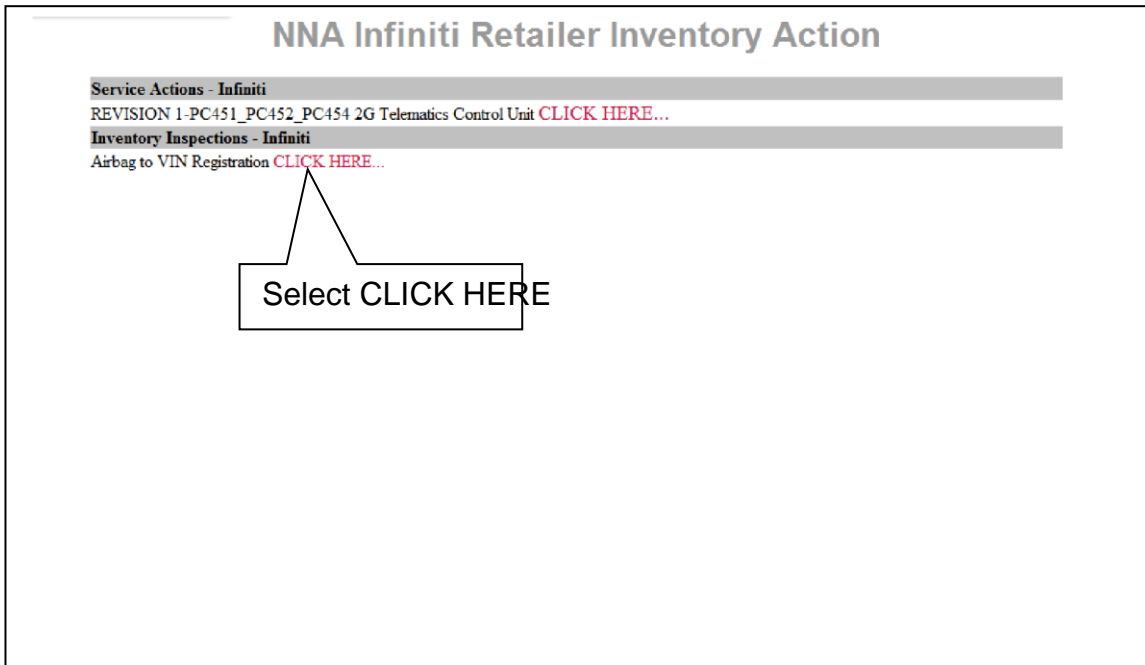

Figure 3

6. Use the quick scan tool to scan the bar code (serial number) on the side of the box of the new inflator (see Figures 6 and 7). □ The serial number will automatically populate (see Figure 5).

NOTE: DO NOT scan the part number label.



Figure 6

NOTE: If needed, the serial number can be entered manually.

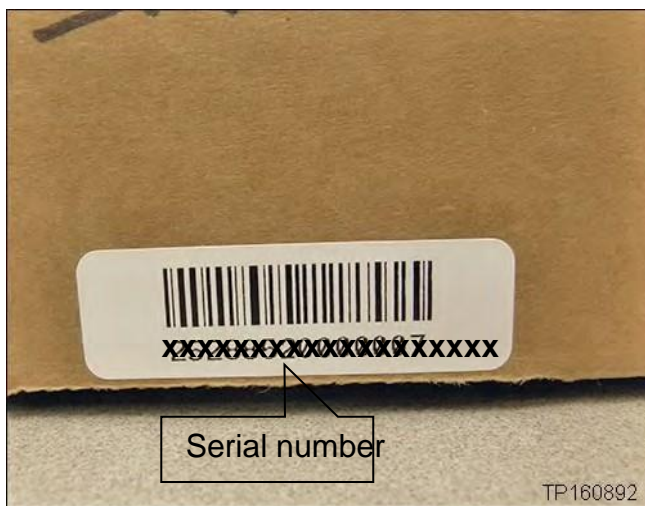

Figure 7

7. Select **Submit** on the ASIST screen (see Figure 5 on the previous page).

Register the New Module

- Use the quick scan tool and scan the bar code (VIN) on the vehicle B-pillar label a second time.

NOTE:

- Some labels may not scan quickly.
- Hold the scan tool approximately 6 inches away from the label.
- Hold the trigger down until the label is read (this may take several seconds).
- The VIN will automatically populate (see Figure 8 Figure 9 on the next page).
- If needed, VIN can be entered manually.



[Airbag to VIN Registration](#)

11/28/2016 1:36:32 PM

Please enter/scan the VIN and Airbag Inflator Serial Number

Dealer Code

Key Number

VIN

Airbag Serial Number

Step 12; see next page.
(Select submit after both fields are populated).

Figure 9

Inflator and Module Replacement

IMPORTANT:

- Follow all cautions, warnings, and notes in the Electronic Service Manual (ESM) when working on or near a Supplemental Restraint System (SRS), such as an air bag. □ To help avoid damage, refer to Instrument Panel Removal Tips starting on the next page.

CAUTION: Handle interior trim carefully to avoid damage. Work with clean hands and clean tools to avoid dirt and stains. Use protective covers as needed.

13. Write down the radio settings.

Presets	1	2	3	4	5	6
AM						
FM 1						
FM 2						
SAT 1						
SAT 2						
Bass	Treble		Balance		Fade	Speed/en. Vol.

14. Turn the ignition OFF.
15. Disconnect both battery cables, negative cable first.
16. Wait at least 3 minutes.
17. Remove the passenger air bag module (module) from the vehicle.

- Refer to the ESM, Section **RS-Restraint System**, for module removal. □ Refer to Instrument Panel Removal Tips starting on the next page.

18. Once removed, set the module in a clean working area.

- Go to page 18.

Instrument Panel Removal Tips

NOTE: To remove the module, the instrument panel needs to be removed. Refer to the tips on the next few pages to help avoid damage to the grilles and instrument panel.

Upper ventilator grille:

□ Carefully pry with a suitable plastic trim tool.



Figure 12

- When there is enough of a gap, insert a second plastic trim tool to unsnap more pawls.

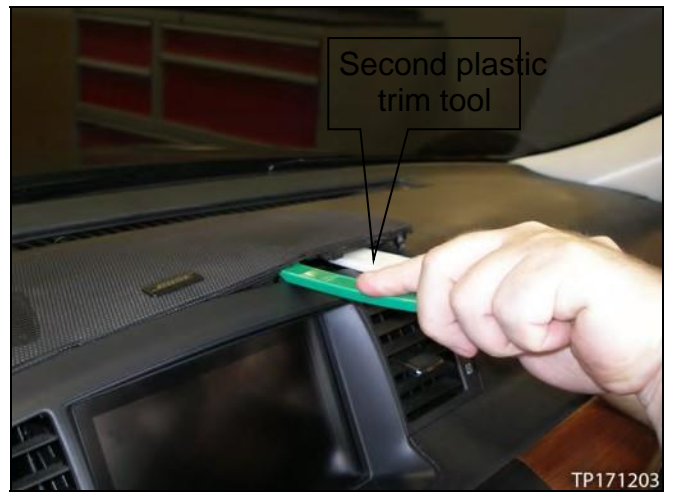

Figure 13

- When able, unsnap the remaining pawls by hand, and then remove the upper ventilator grille.



Figure 14

Center ventilator grille:

- Place plastic inserts or similar material between the sides of the center ventilator grille and instrument panel pad.
- This will keep the center ventilator grille locator tabs from “catching” the instrument panel pad during removal.
- See Figure 16 for samples of plastic inserts.

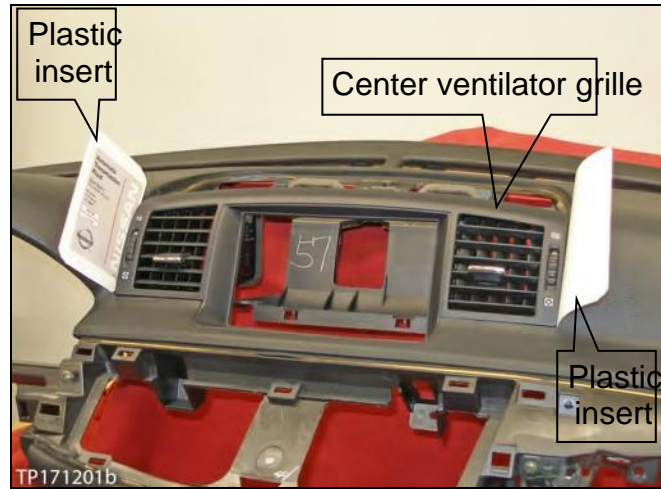

Figure 15

- See location of locator tabs and where they fit in the instrument panel pad in Figure 17 and 18.



Figure 16

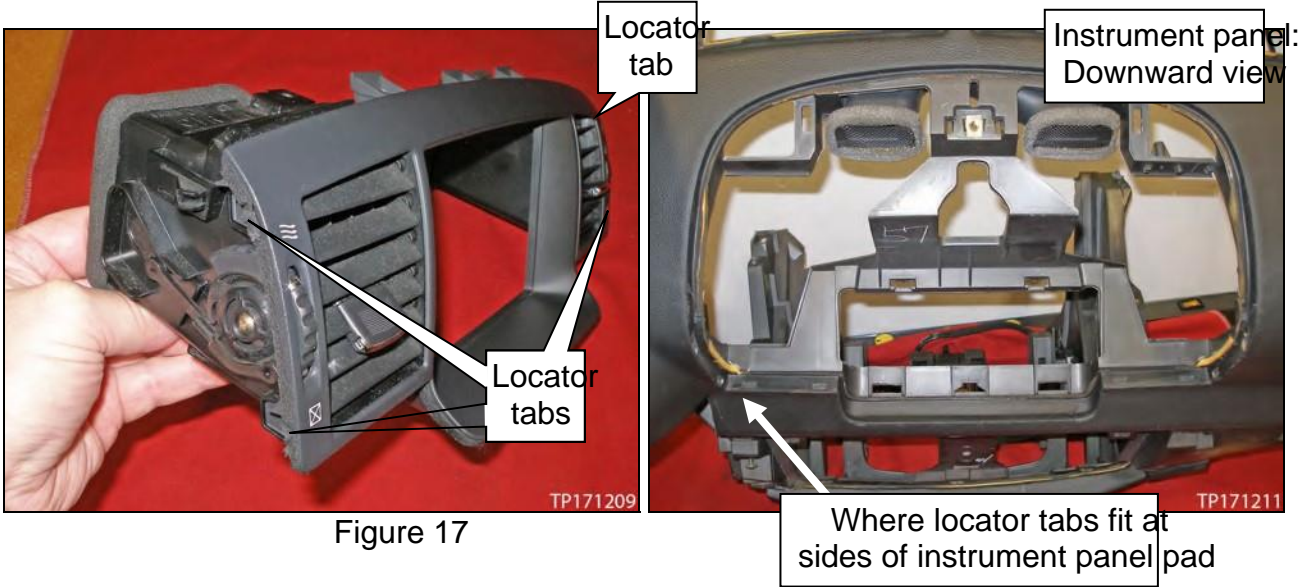

Figure 17

Figure 18

- Grab the center ventilator grille, and then pull up.

CAUTION: Removing the center ventilator grille in a direction other than up may cause damage to its lower pawls, or instrument panel pad.

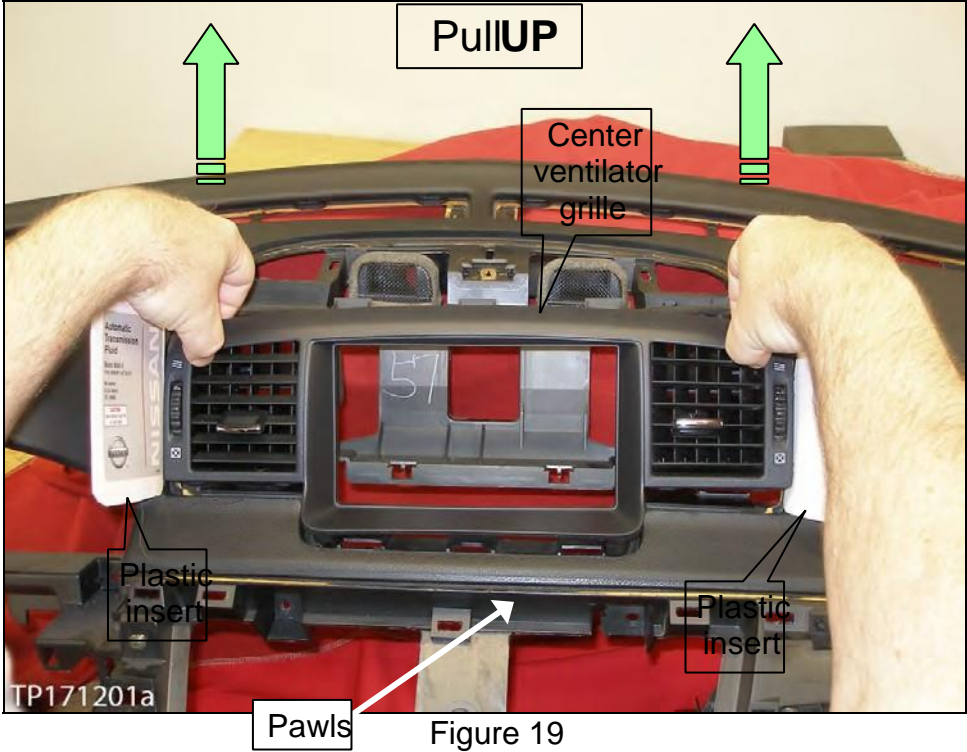

Figure 19

Side ventilator grilles:

- Remove the screw at the side of each side ventilator grille.
- Place plastic inserts or similar material between the sides of the side ventilator grilles and instrument panel pad.
 - LH side ventilator grille shown.
 - See Figure 16 for samples of plastic inserts.

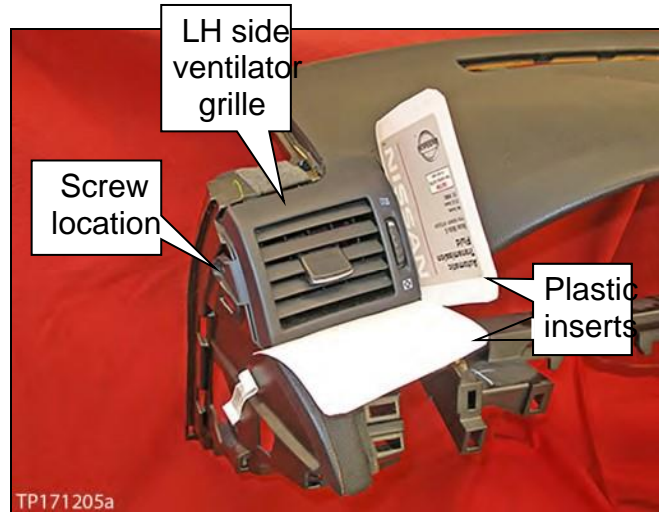

Figure 20



- See location of pawls and related locator tabs and where they fit in the instrument panel pad in Figure 21, 22, and 23.

Figure 21



Figure 22

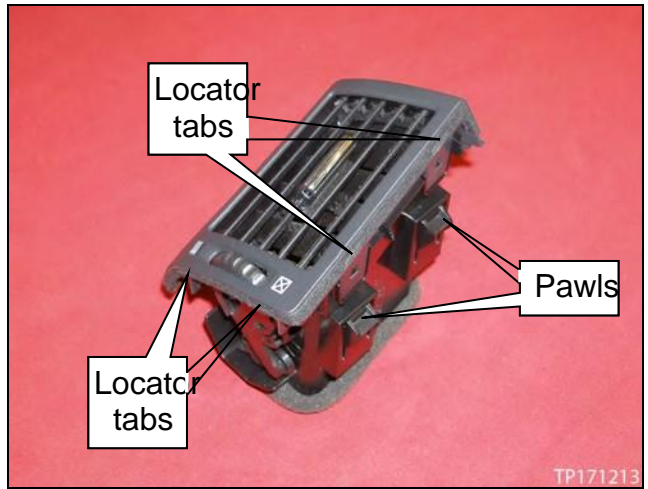

Figure 23

- Remove the side ventilator grille as shown in Figure 24.

CAUTION: Removing the side ventilator grilles in a different manner may cause damage to it or the instrument panel pad.

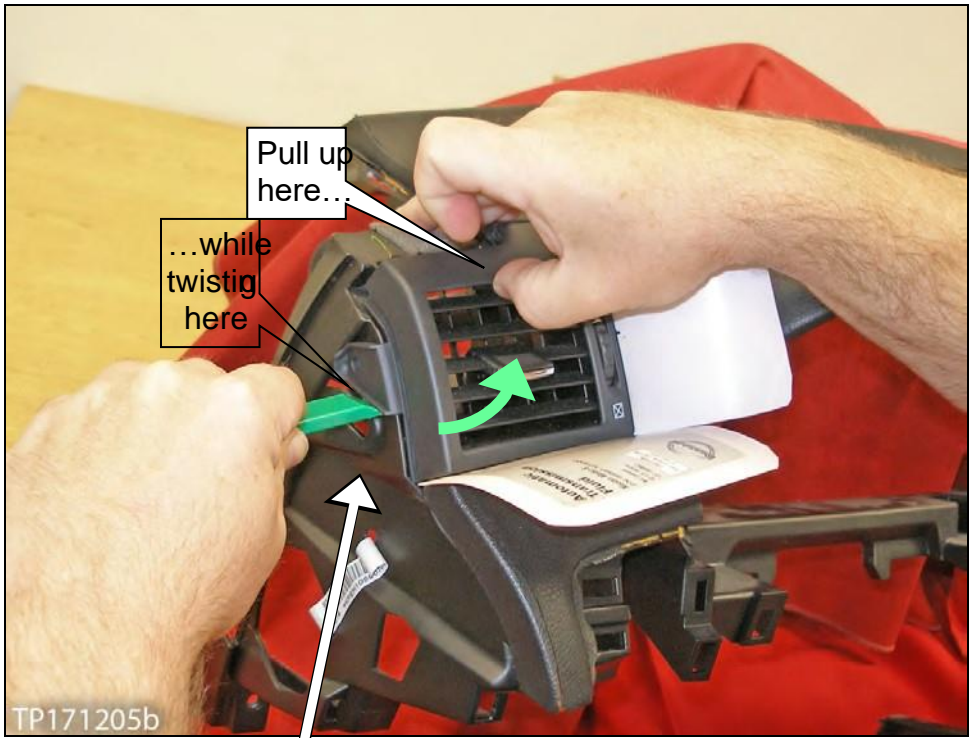

Figure 24

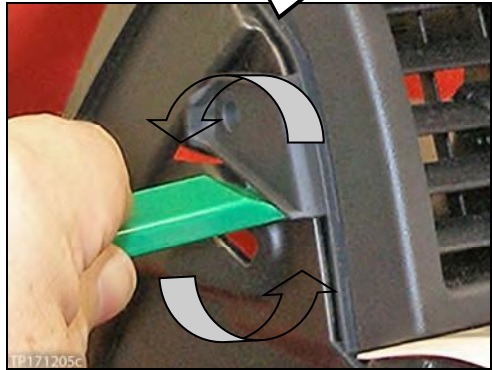
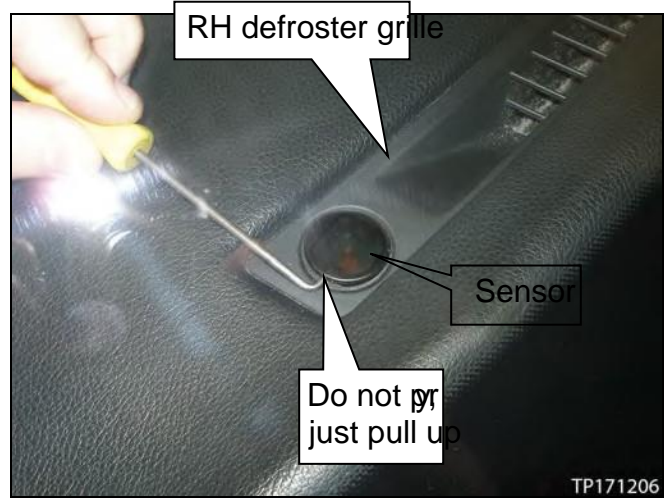

Figure 25

Front defroster grilles:

- Carefully unfasten/disconnect/remove the sensors in both LH and RH defroster grilles.

- Use a pick or other similar tool. Do not pry on the defroster grille, simply pull up.



- Place a plastic insert or similar material ^{Figure 26} between the defroster grille and instrument panel pad.

- This will keep the defroster grille from “catching” onto the instrument panel pad.
- Examples of plastic inserts shown in Figure 16 can be used.
- With the same type or similar tool used in Figure 26, hook under the defroster grille and then carefully pull up.

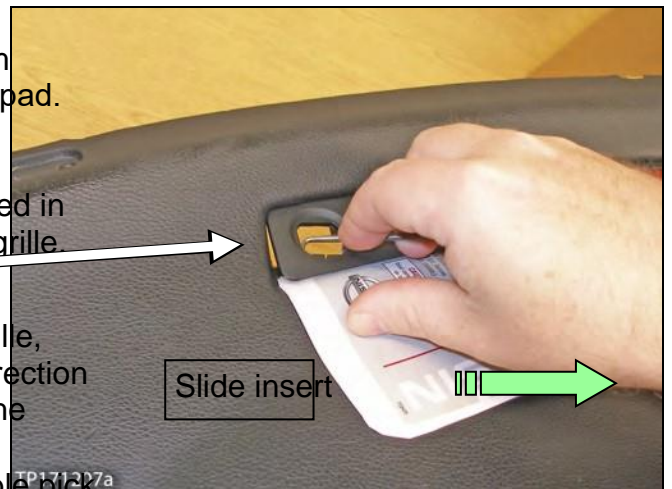

- When able, take hold of the defroster grille, and then slide the plastic insert in the direction of (carefully) lifting up and unsnapping the pawls.
- If the pawls will not release, use a suitable pick and gently pry them loose (toward the defroster ^{Figure 27} grille’s opening).



Figure 28

Figure

29

19. Securely mount the air bag module support (support) in a vice (see Figure 30 and 31).

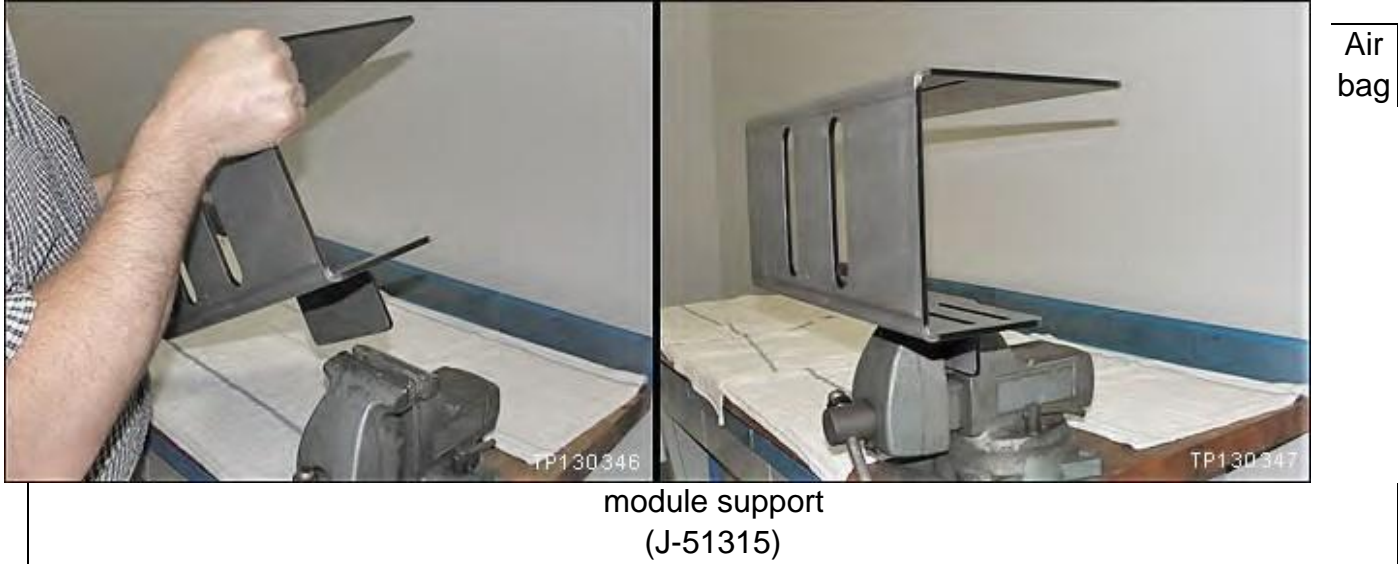

Figure 30

Figure 31

WARNING:

- Work from behind and to the sides of the support. □
- Wear safety glasses while performing inflator replacement.

20. Unclip the harness from the harness guides.

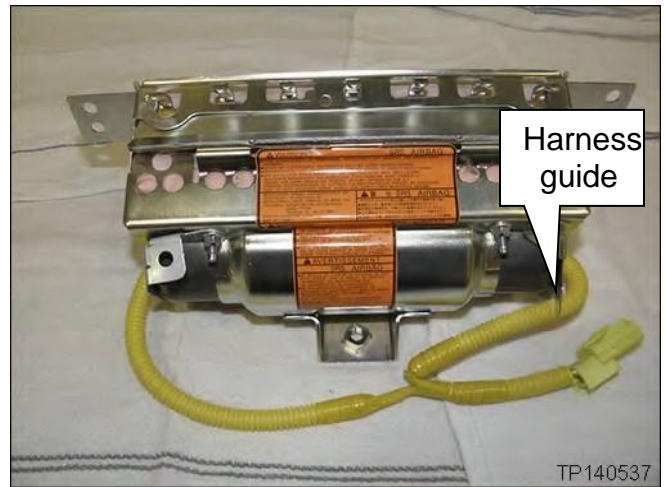

Figure 32

21. Attach the FX brackets to the support as shown.
- Make sure the convex parts of the brackets are in the UP position.
 - Use bolts and nuts supplied with the support.
 - Leave the bolts/nuts slightly loose to allow for positioning of the module.

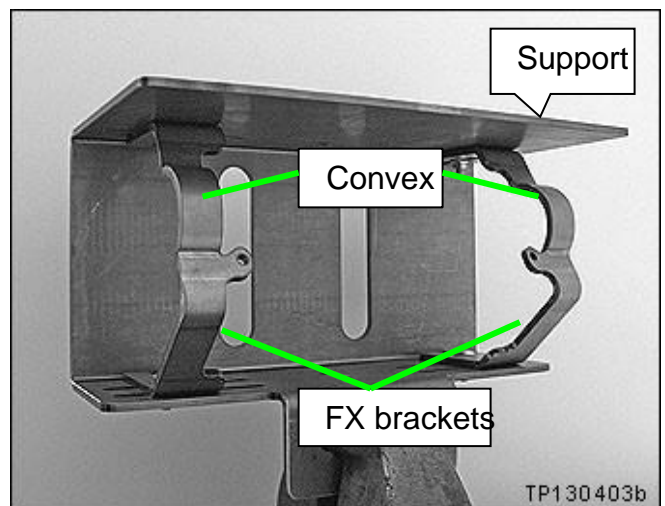

Figure 33

22. Attach the module to the FX brackets in the support as shown.

- Use bolts and nuts supplied with the support.
- Make sure the arrow on the bag is pointing down.

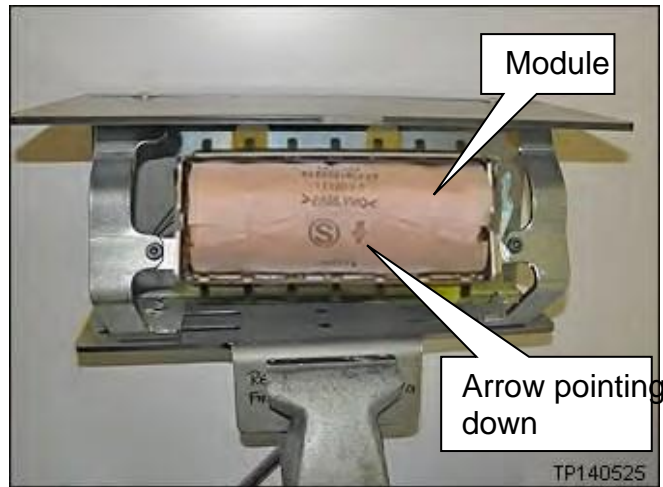

Figure 34

23. Make sure the module is centered in the support.

NOTE: Centering the module in the support will allow access to the inflator securing nuts through the slots in the support.

24. Tighten all of the mounting bolts and nuts that hold the module and brackets to the support.

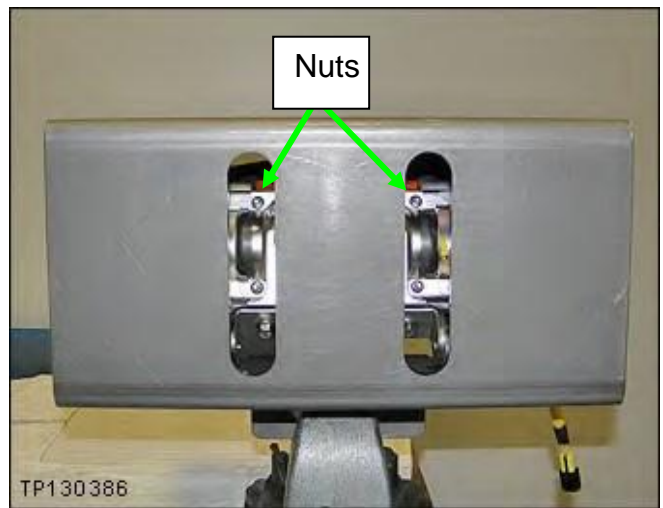
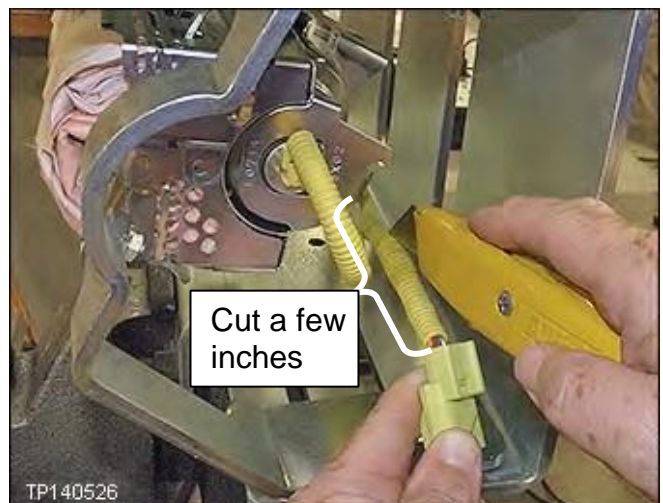

Figure 35

WARNING: Work from behind and to the sides of the support.

25. Carefully cut a few inches of the yellow corrugated harness cover in the area shown.

- **Do not** cut the wires inside the corrugated cover.



26. Attach 2 shorting pins to the inflator harness as shown.

- Make sure to pair the wires from each end of the inflator.

Blue with White

Red with Yellow

- Use an insulation displacement type wire connector as a shorting pin.
- Refer to the Parts Information for additional connector/shorting pin information.

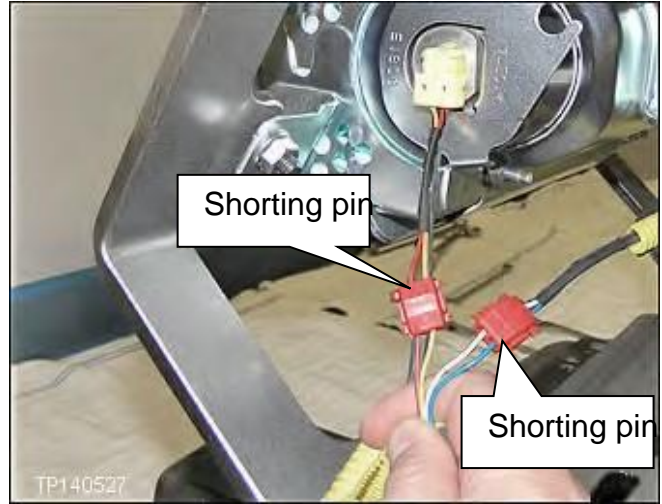

Figure 37

27. Cut off the connector end of the harness.



Figure 38

28. Remove the 4 nuts from the module that hold the inflator in place (see Figures 39 and 40).

- Use a ratchet and extension.



Figure 39

- Remove the 4 nuts.

NOTE: These nuts will not be reused.



Figure 40

29. Remove the inflator stopper.

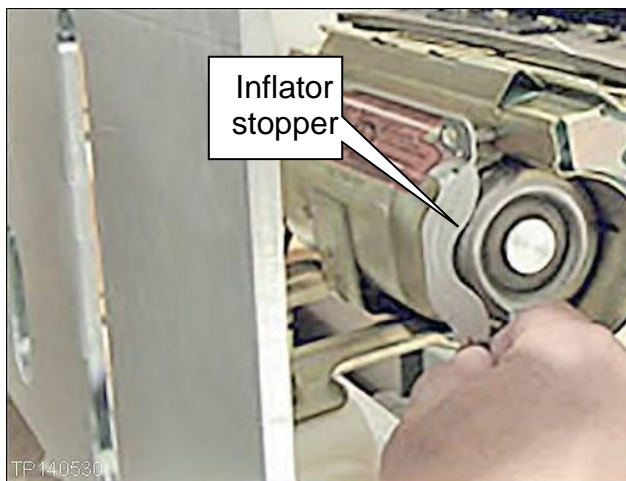

Figure 41

30. Push the left side of the inflator out of module.
 - Twist the inflator to a position that allow the connector and harness fit through the opening.

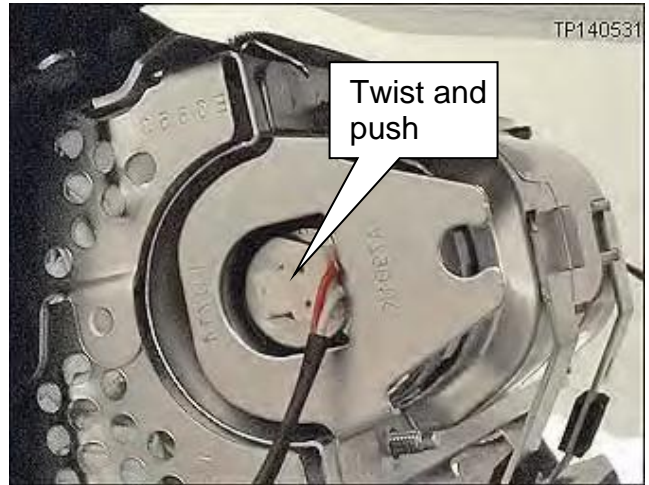

Figure 42

the
will
to

31. Pull the inflator completely out of the module from the right side.
32. Set the old inflator in the clean working area and make sure it does not roll and to the floor
33. **Remove the old module from the FX brackets in the support.**



Figure 43

fall

**IMPORTANT: This old module
not be reused.**

will

IMPORTANT: In the following steps, a new module and inflator are used.

34. Remove the new module from its shipping container. □ New module is included in the Module Kit.
35. Slide the paper tube out of the new module.

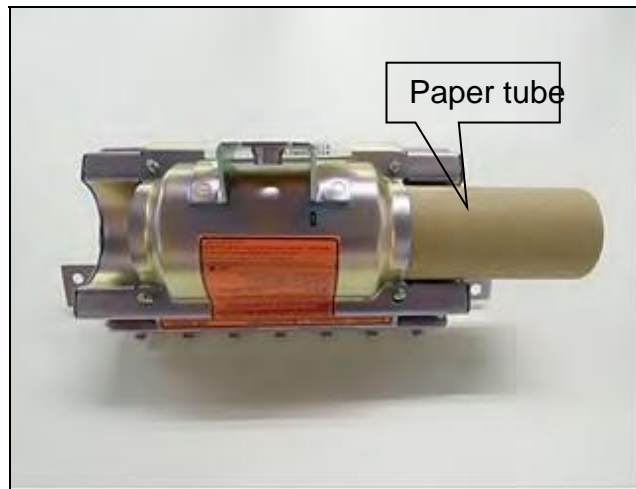

Figure 44

36. Install the **left** side inflator stopper bracket) with nuts finger tight.
 - Make sure to **use new nuts**. □ New nuts and new stopper bracket are included in the Module Kit.

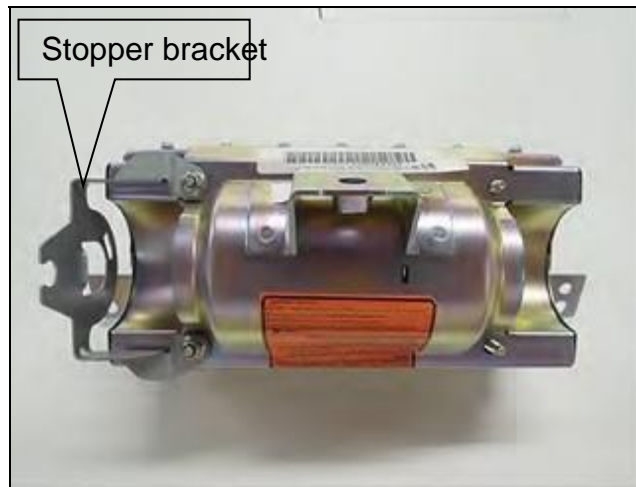

Figure 45

37. Attach the new module to the FX brackets in the support as shown.
 - Use bolts and nuts supplied with the support. □ Make sure the arrow on the bag is pointing down.

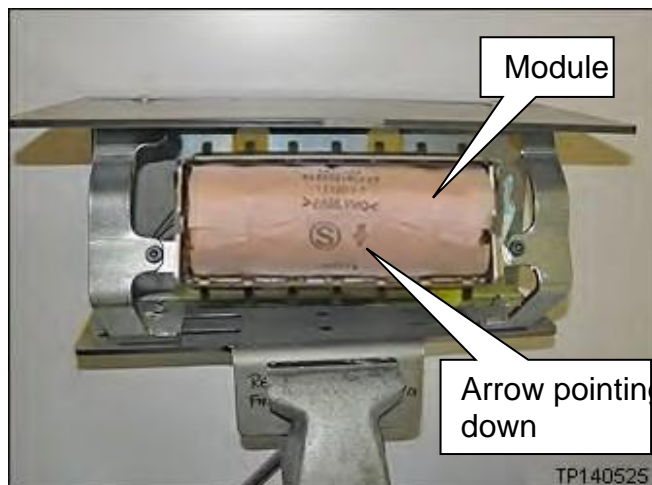

Figure 46

38. Remove the new inflator from the box.

39. Place the removed (old / non-deployed) inflator in the box that the new inflator arrived in.
- Follow the return instructions provided by Takata.
 - Return instructions provided by Takata are attached to this bulletin on page 33.
- Install the New Inflator into the New Module

40. Insert the new inflator large end first, as shown in Figure 47 from the right side.

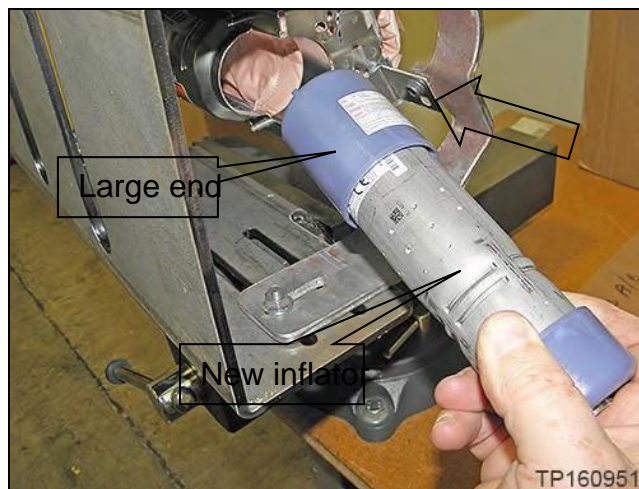

Figure 47

41. Align the inflator tab and then insert it through the hole in the left side inflator stopper bracket.

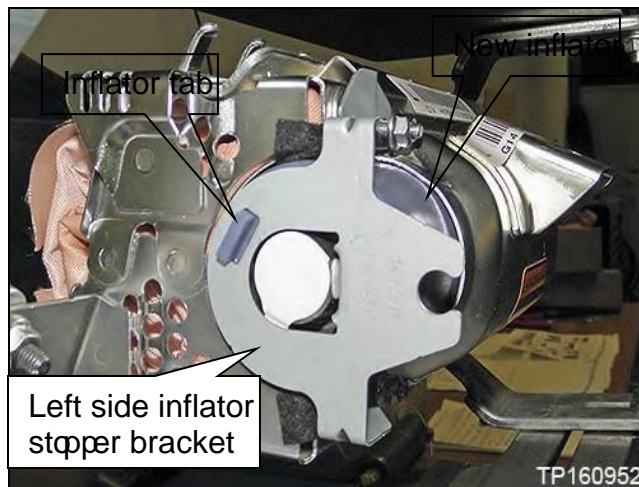

Figure 48

42. Install the **new** right side inflator stopper bracket (shown in Figure 49) with nuts finger tight.

- Make sure to **use new nuts**. □ New nuts and new stopper bracket are included in the Module Kit.

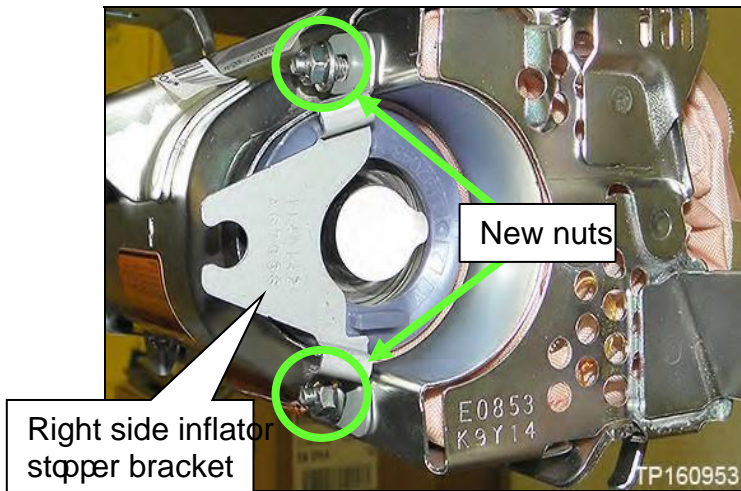

Figure 49

43. Push the new right side inflator stopper bracket against the Inflator.

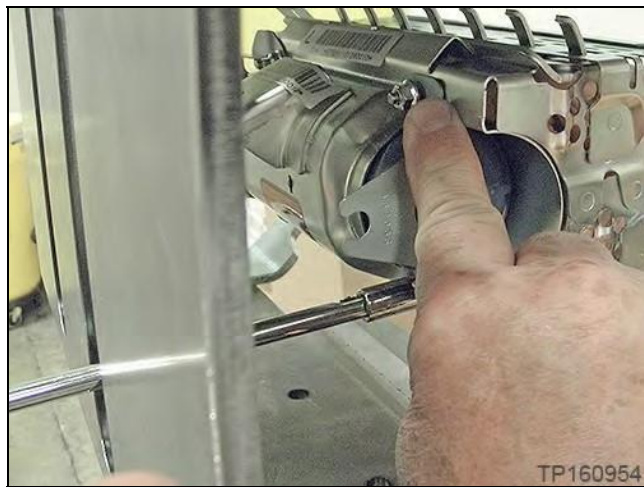

Figure 50

□ Make sure the inflator is pushed all the way into its housing – no gap on the left side (see Figure 51).

- Make sure there is no gap between the inflator stopper bracket and the inflator on the right side (see Figure 51).

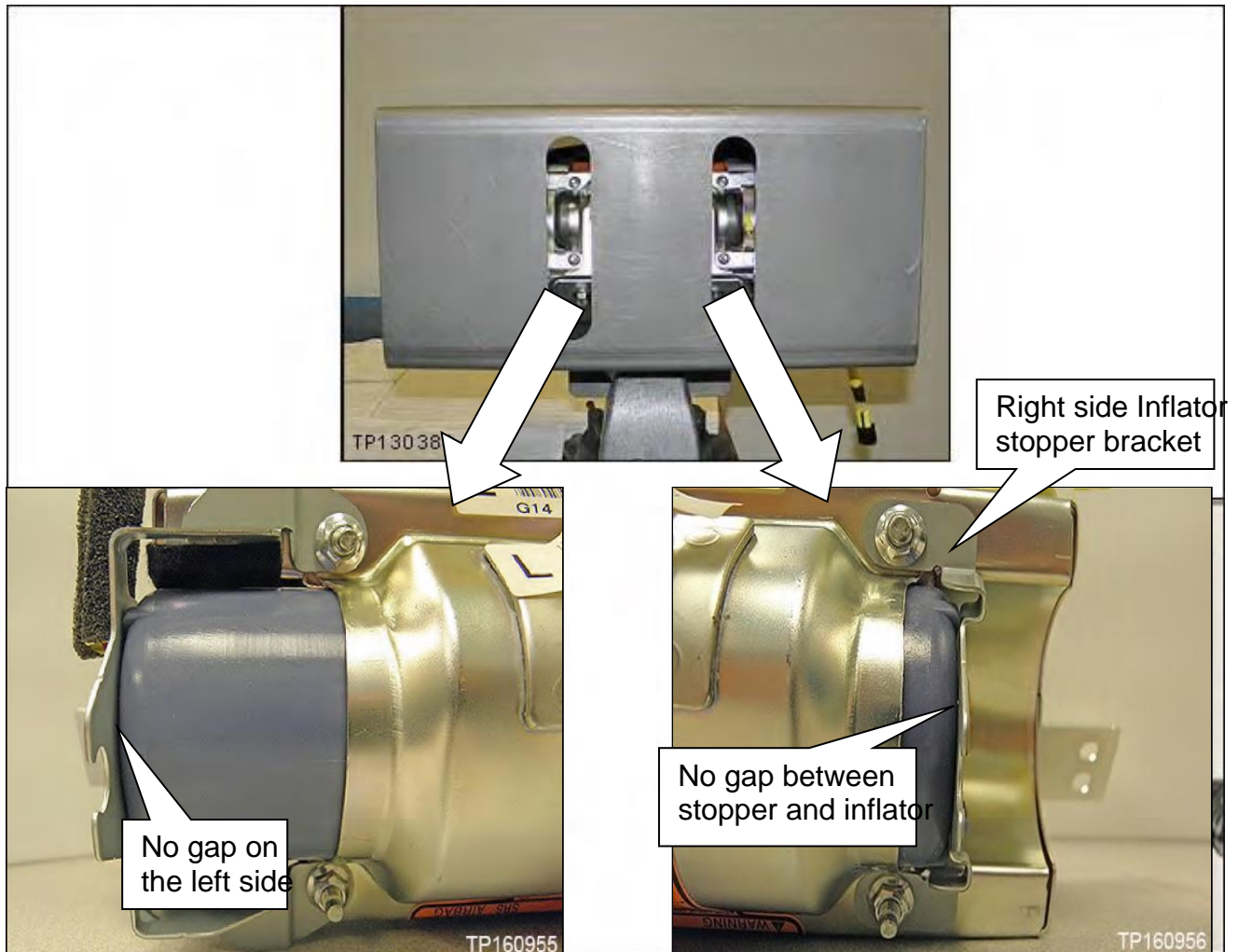
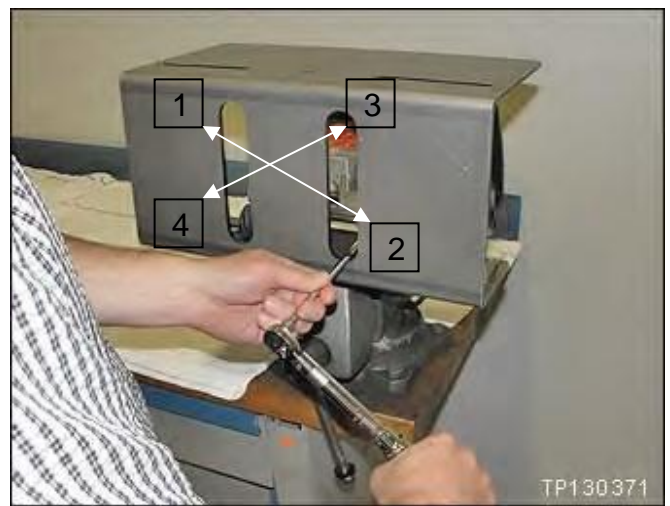

Figure 51

44. Torque the 4 inflator securing nuts.

- Torque nuts to: 3.9 N•m (0.39 kg-m, **34 in-lb**).
- **Torque in the order shown.**



IMPORTANT:

□ In the next step, on the next page, you will be attaching the new harness to the new inflator.

- Once an inflator connector is attached to the inflator, it cannot be disconnected.
- **Make sure to attach the connectors to the correct ends of the inflator (see Figure 53).**

45. Attach the new harness to each end of the inflator.

- Remove the dust proof stickers covering the ends of the inflator. □ Refer to Figures 53, 54, and 55.

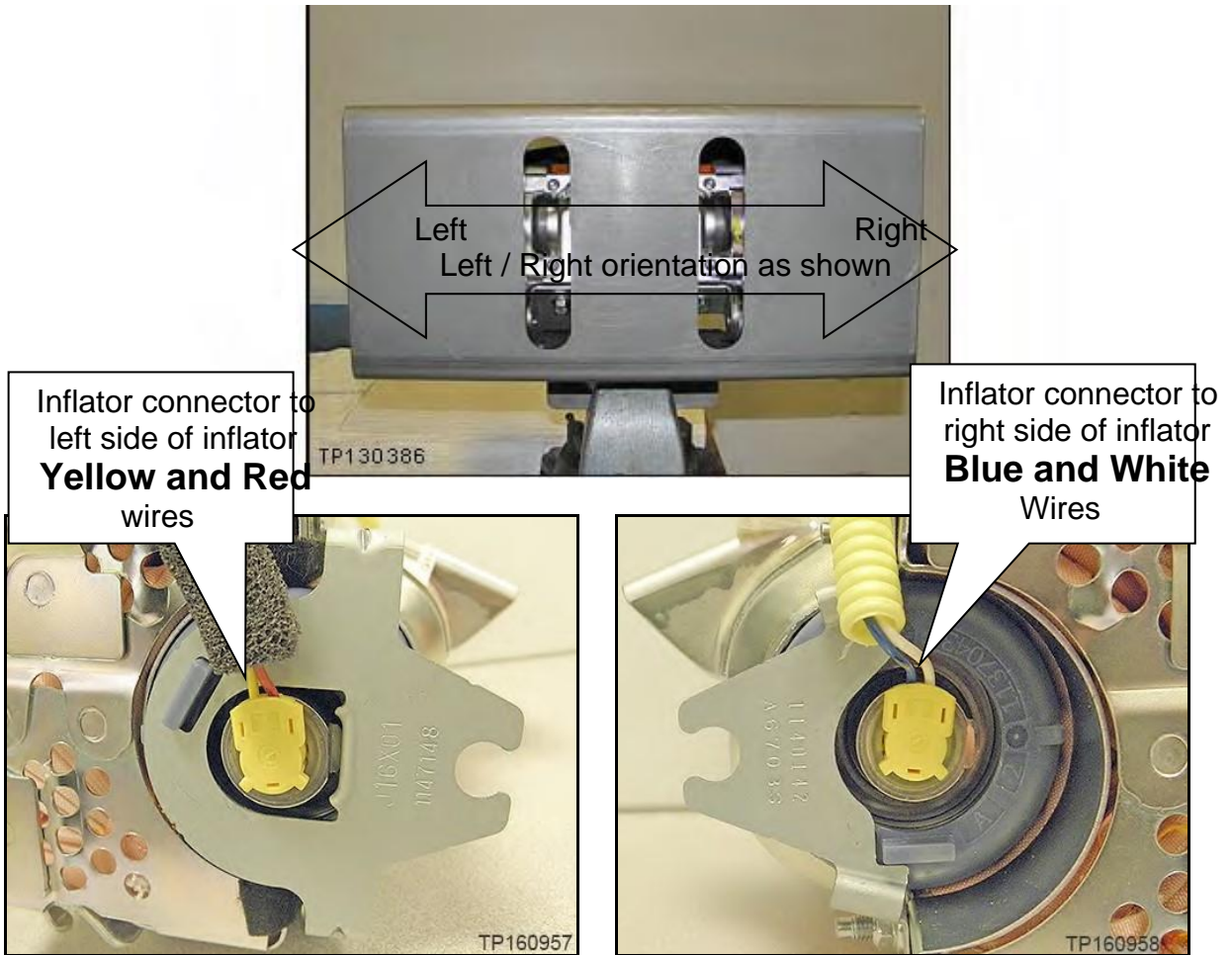

Figure 53

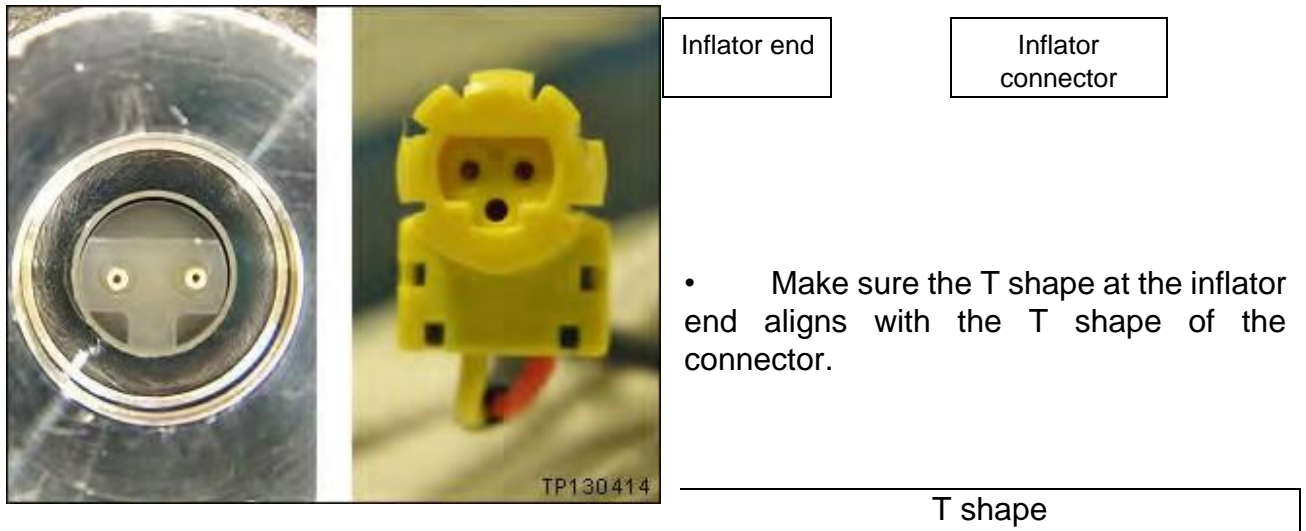

Figure 54

- Make sure harness connector is fully engaged / seated (see Figure 55).

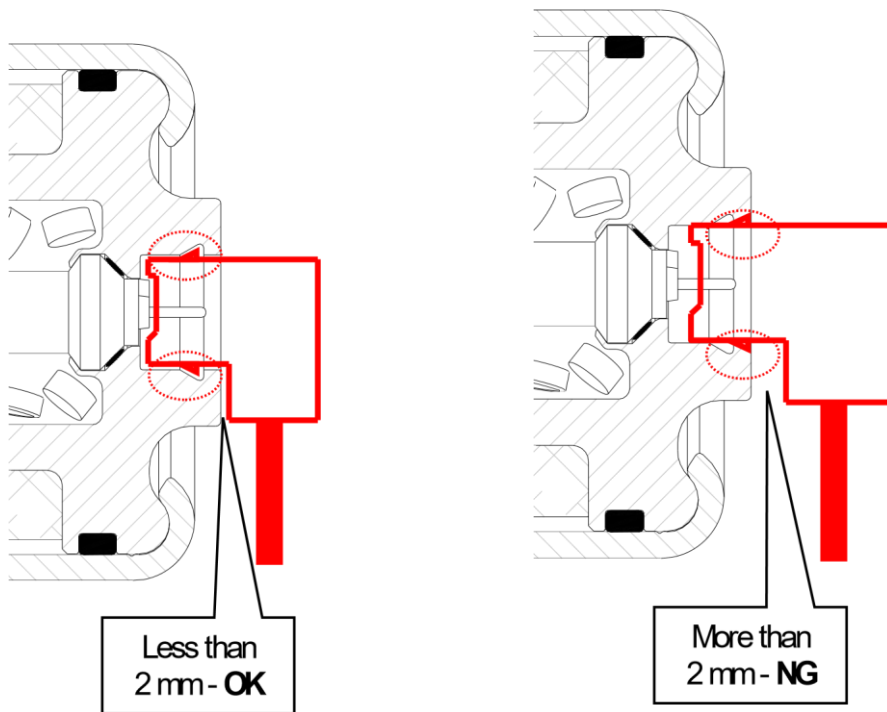

Figure 55

46. Remove the module from the support and set it on the clean working area.



Figure 56

47. Reinstall the module into the vehicle in reverse order of removal.
 - Make sure to use the new “one time use” module mounting bolt included with the Module Kit, listed in the Parts Information.

48. Re-connect both battery cables – positive cable first.

49. Reset the clock and the radio settings.

50. Turn the ignition from OFF to ON and observe the air bag warning light:

- Light should illuminate for 7 seconds and then go out.

NOTE: If the Air Bag Warning light does not operate as described above there may be an issue not covered by this campaign. Refer to ASIST and the appropriate Service Manual for additional diagnostic and repair information.

51. Return the removed (old / non-deployed) inflator in the box that the new inflator arrived in.

- Follow the return instructions provided by Takata.
- Return instructions provided by Takata are attached to this bulletin on page

33.

PARTS INFORMATION

DESCRIPTION	PART NUMBER	QUANTITY
MODULE KIT – SUB (Includes cushion, harness, module mounting bolts, inflator securing nuts and two brackets.)	K8515-EH19E	1
INFLATOR-AIR BAG ASST (Inflator)	98561-7999E	1
Shorting Pin (Insulation Displacement Connector for 22-18 gauge wire)	NAPA item # 784566 Grainger Item # 4YT50	2

	or equivalent available from local auto supply	
---	--	--

NOTE:

- **Make sure to return the removed (old / non-deployed) inflator in the box that the new inflator came in.**
- **Follow the return instructions provided by Takata. □ Return instructions provided by Takata are attached to this bulletin on page 33.**

CLAIMS INFORMATION

NOTE: Use Service COMM and the VIN to confirm the correct campaign ID number for a given vehicle. The correct number must appear on all communication and documentation of any nature dealing with this campaign.

Submit a “CM” line claim using the following claims coding:

CAMPAIGN (“CM”) I.D.	DESCRIPTION	OP CODE	FRT
R1622	Remove and replace front passenger air bag and inflator	R1622B	2.7 hrs.

OR

CAMPAIGN (“CM”) I.D.	DESCRIPTION	OP CODE	FRT
R1701	Remove and replace front passenger air bag and inflator	R17016	2.7 hrs.

OR

CAMPAIGN (“CM”) I.D.	DESCRIPTION	OP CODE	FRT
R1704	Remove and replace front passenger air bag and inflator	R1704B	2.7 hrs.

OR

CAMPAIGN (“CM”) I.D.	DESCRIPTION	OP CODE	FRT
R1706	Remove and replace front passenger air bag and inflator	R17067	2.7 hrs.

OR

CAMPAIGN (“CM”) I.D.	DESCRIPTION	OP CODE	FRT
R1707	Remove and replace front passenger air bag and inflator	R1707J	2.7 hrs.

EXPENSE CODE	DESCRIPTION	MAXIMUM AMOUNT
041	Shorting Pin (Insulation Displacement Connector for 22-18 gauge wire)	\$0.50

AMENDMENT HISTORY

PUBLISHED DATE	REFERENCE	DESCRIPTION
March 14, 2017	ITB17-024	Original bulletin published

June 15, 2017	ITB17-024a	CLAIMS INFORMATION and page 1 revised
October 3, 2017	ITB17-024b	Changes made throughout
January 4, 2018	ITB17-024c	Changes made throughout
January 15, 2020	ITB17-024d	CLAIMS INFORMATION revised and Campaign ID #'s added



Takata Document

NOTE

NOTE: International (including Mexico and Canada), Hawaii, Alaska, Puerto Rico, and US Virgin Islands dealers **CANNOT** follow below shipping instructions. Instead, dealerships in these locations **MUST** contact the following Takata/Merco USA representative directly for shipping instructions: Miguel Prigadaa – Tel#: 210-250-5078 or Email: MLGTakataRestraints_International@XPO.com

NOTE: For Continental US 48 State dealerships, please follow steps 1-8 below.

- Specific to Step 4 below:
 - Follow step 4a if you receive the updated NON-FedEx label. Proceed to step 5.
 - Follow step 4b if you receive the FedEx label. Proceed to step 5.

1. Shipping Documents

a) Box Label

- Supplied with each Kit
- To be affixed to each box



b) Over-pack Label

- To be supplied by XPO
- To be affixed to the outside of each pallet



c) Bill of Lading

- To be supplied by XPO
- Print 2 copies: 1 for Dealer Records, 1 for LTL Driver



d) ERG Document

- To be supplied by XPO
- To be provide by the Dealer to the LTL Driver for each shipment



2. Packing Instructions

a) Confirm box is in acceptable condition. If a new box is needed, follow the New Box instructions located in Box 8 of this page.

b) Place the un-deployed air bag inflator in the "cradle" of the box insert.



3. Closure Instructions

a) Close the top box flap, per box closure instructions located on front panel of box.



4a. Shipping Instructions - Label each Box

a) New Labels will begin shipping in each kit starting mid June, 2015

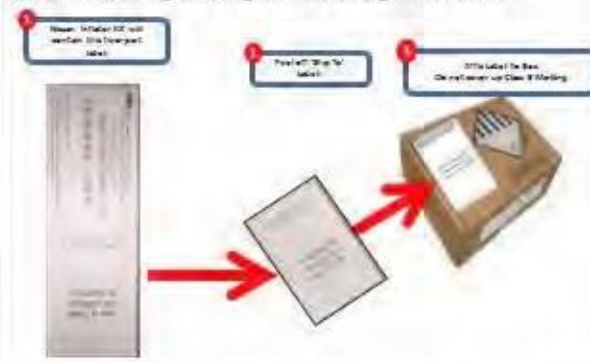

5. Shipping Instructions – Prepare the Pallet

- Accumulate and palletize Kits
- Arrange Kits on Pallet as pictured here
 - 20 boxes per row/layer (5x4)
 - 10 rows/layers per pallet (200 boxes)
- Shrink-wrap Kits to Pallet
- Affix Over-pack Label on (1) side of Pallet (Not on Top)



6. Shipping Instructions – Schedule LTL Pickup

- Upon Accumulating 200 kits (1 Over-pack/Pallet) Minimum
 - Call XPO at 1-210-250-5079
 - If 200 Kits have not been accumulated in 30 days, please call XPO for direction
- Have the following information Available
 - Dealer #
 - Quantity of Over-packs/Pallets
 - Quantity of Passenger Inflator Kits on each Pallet
 - Email Address where shipping Documentation can be received

7. Shipping Instructions – Ship

- Give 1 Copy of BOL and 1 Copy of ERG to Driver
- Retain 1 Copy of BOL for Dealership records and archive for 2 Years

8. Requesting a New Box / Shipping Labels

If a new box or replacement shipping labels are needed, please contact the representative listed below by phone or email to request replacement materials.

Primary Contact: Armando Gonzalez - Tel #: 210-250-5079

E-Mail: SCFieldaction.14305@xpo.com

To help expedite your request, please be prepared to provide the following information:

- Serial number on the original box
- What Type of shipping material needed
 - Replacement Box
 - Two Part Return Label
 - Bill of Lading
 - ERG Form
- Dealer Shipping Information
 - Contact name
 - Dealer Address
 - Phone Number



