



UPDATE! RECALL CAMPAIGN 15V-147: HEAD PROTECTION SYSTEM (RIGHT SIDE)

New information provided by this revision is preceded by this symbol **UPDATE!**.

Please perform the procedure outlined in this Service Information on all affected vehicles before customer delivery. In the event the customer has already taken delivery of the vehicle, please perform the procedure the next time the vehicle is in the shop.

This Service Information bulletin replaces SI B65 05 15 dated **March 2015**

What's New:

- Parts Ordering Procedure
- Recall label information removed
- 15V-147 NHTSA ID number added
- Delivery stop information removed
- Procedure (special tool)
- Tread Act statement added

MODEL



F15 (X5) produced from August 30, 2013 to February 18, 2015

SITUATION

BMW AG is conducting a voluntary Safety Recall involving the Head Protection System (HPS) on certain Model Year 2014 and 2015 X5 Sports Activity Vehicles (SAVs).

AFFECTED VEHICLES

This Recall Campaign involves F15 (X5) models produced from August 30, 2013 to February 18, 2015.

Vehicles which require this Recall Campaign to be completed will show it as "Open" when checked either in the "Service Menu" of DCSnet (Dealer Communication System) or with the Key Reader.

CAUSE

Due to a supplier production control error, the clamp which secures the HPS air bag to the gas generator is out of specification. As a result, it is possible that an insufficient inflation of the air bag could occur during activation of the HPS.

CORRECTION

Replace the HPS (right side).

PROCEDURE

UPDATE!

This repair procedure requires a special clip release tool, which was sent via automatic tool shipment. Refer to SI [B04 06 15](#) for information about this tool (P/N 83 30 0 496 932).

Refer to ISTA repair instructions for safety and precaution measures when dealing or handling airbags.

For vehicles equipped with SA 402, Panoramic sunroof: refer to RA 72 12 048.

For vehicles equipped without SA 402: refer to RA 72 12 060.

A copy of the main repair instructions is attached to this Service Information.

PARTS INFORMATION

UPDATE!

These parts are now open for normal parts ordering. It is no longer required to order these parts VIN specific.

Part Number	Description	Quantity
72 12 7 325 698	Head airbag, right	1
07 14 7 265 827	Blind rivets	8

WARRANTY INFORMATION

The repair described in this bulletin is covered under warranty regardless of time or mileage.

Reimbursement for this Recall will be via normal claim entry utilizing the following information:

Defect Code:	00 72 53 01 00
---------------------	-----------------------

Completion before vehicle delivery to the customer or the vehicle is already in the workshop

Labor Operation:	Labor Allowance:	Description:
00 63 537	32 FRU	Replace right head airbag (version without panoramic sunroof SA 402)
Or:		
00 63 538	34 FRU	Replace right head airbag (version with panoramic sunroof SA 402)

Or:

Completion after vehicle delivery to the customer

Labor Operation:	Labor Allowance:	Description:
00 63 010	34 FRU	Replace right head airbag (version without panoramic sunroof SA 402)
Or:		
00 63 011	35 FRU	Replace right head airbag (version with panoramic sunroof SA 402)

ADDITIONAL INFORMATION

PERFORM THE PROCEDURE OUTLINED IN THIS SERVICE INFORMATION ON ALL AFFECTED VEHICLES BEFORE CUSTOMER DELIVERY OR THE NEXT TIME THEY ARE IN THE SHOP FOR MAINTENANCE OR REPAIRS.

BMW centers must ensure Recalls are completed after having been notified by BMW of North America, LLC (BMWNA) that a safety-related defect or noncompliance exists in any motor vehicle or item of replacement equipment in the center's possession at the time of notification. In BMW NA's case, this notification would typically be made by the issuance of a Recall notification in the form of a Service Information bulletin (SIB) or transmission of a Dealer Communication System (DCS) Recall message.

Under the National Traffic and Motor Vehicle Safety Act of 1966, as amended, if a Recall campaign is announced by BMW NA, centers must ensure that all Recalls on new vehicles and new items of replacement equipment are completed **BEFORE** delivery to the consumer. This means that centers may not legally deliver new motor vehicles or new items of replacement equipment to consumers with an open Recall.

The Safety Act also prohibits centers from selling or leasing the motor vehicle or item of replacement equipment, unless and until the open Recall has been completed **BEFORE** delivery. This also pertains to vehicles in the Certified Pre-Owned program, and to items of replacement equipment.

Finally, BMW centers should not sell or use parts that have been recalled by BMW NA. Please follow the specific instructions provided by BMW NA on the return or disposition of the parts.



Reimbursement of Prior Customer-Pay Repairs (TREAD Act)

With this Technical Campaign, a prior repair reimbursement is not likely. Typically, a customer would have their driver's front air bag module replaced as a result of an accident. In such a case, either an insurance company or the customer themselves, paid for the replacement of the above mentioned air bag module in conjunction with the accident repairs. Such cases are not covered by this campaign and are not entitled to reimbursement.

Tuesday, September 18, 2017

ATTACHMENTS

View PDF attachment [B650515 4100 Replacing Rivets](#).

View PDF attachment [B650515 Repair Procedure Without SA402](#).

View PDF attachment [B650515 Repair Procedure With SA402](#).

[Copyright ©2017 BMW of North America, Inc.]

REP-REP-RAGRP41-4105_BLINDNIETE Replacing blind rivets

VIN:	0K54831	Vehicle:	X'/F15/off-road vehicle/X5 35iX/N55/AUT/USA/left-hand drive/2014/08
System Version:	3.48.20.13322	Data Version:	R3.48.20.13322

41 00 ...

Replacing blind rivets

Special tools required:

- 2 348 128
- 72 1 210



Important!

Lay out protective mats to protect the interior against swarf from the drilled-out rivets and damage.

Lay out protective mats in the relevant working area:

- Dashboard
- Entrance area
- Passenger compartment

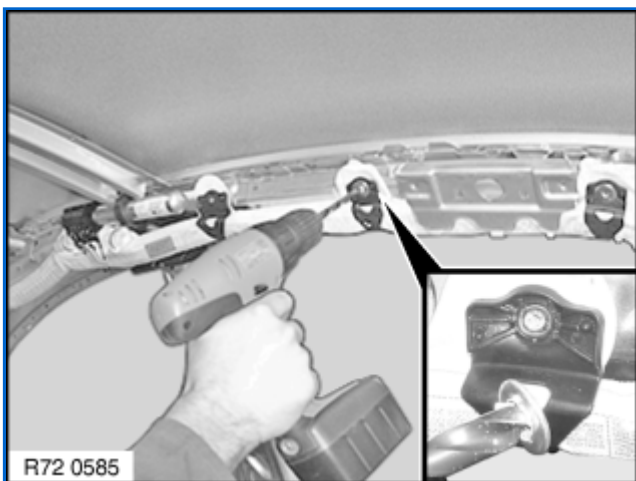

Schematic diagram of folding pack holder for head airbag:

Drill off rivet plate down to rivet shank with a 10 mm twist drill bit.

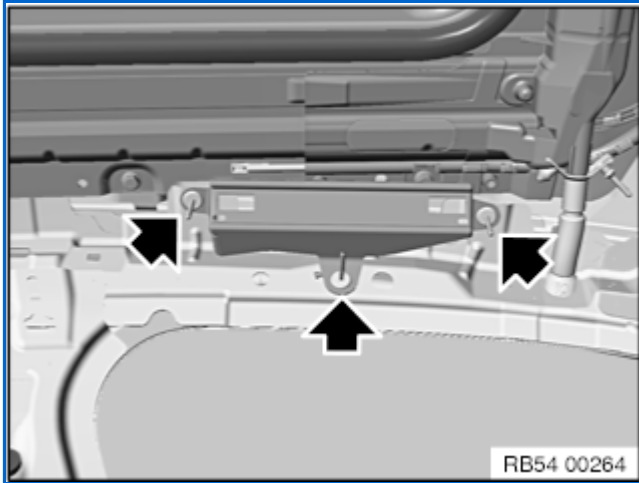

Described for grab handle holder:

Drill off rivet plate down to rivet shank with a 10 mm twist drill bit.

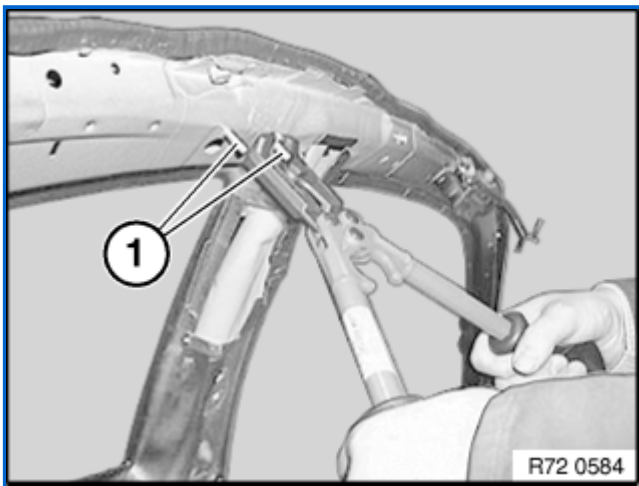

Cut off blind rivet shanks down to sheet metal as level as possible.

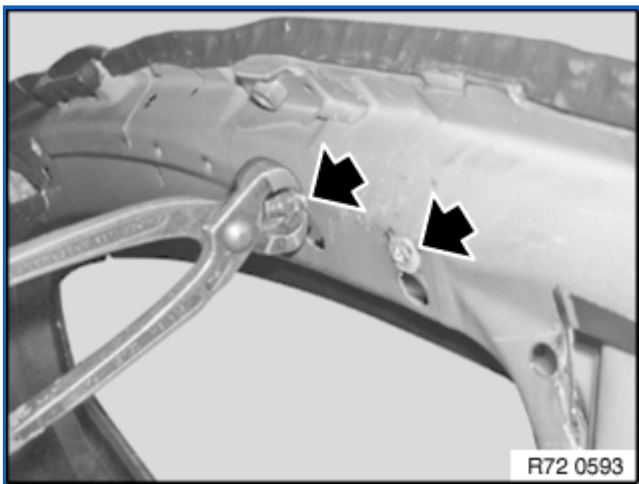

Deburr remaining rivets with nipper pliers.



Installation note:

Apply primer to paintwork damages on side frame.

Note:

Depending on accessibility, the rivet heads will have to be removed using special tool 2 348 128 or 72 1 210.

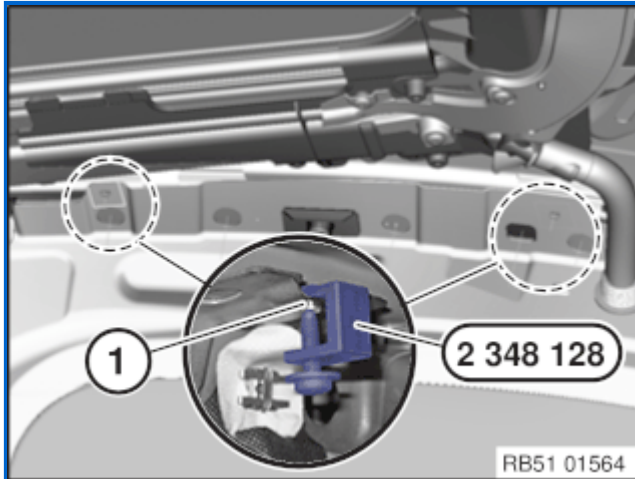

Press off rivet heads (1) using special tool 2 348 128 and remove.

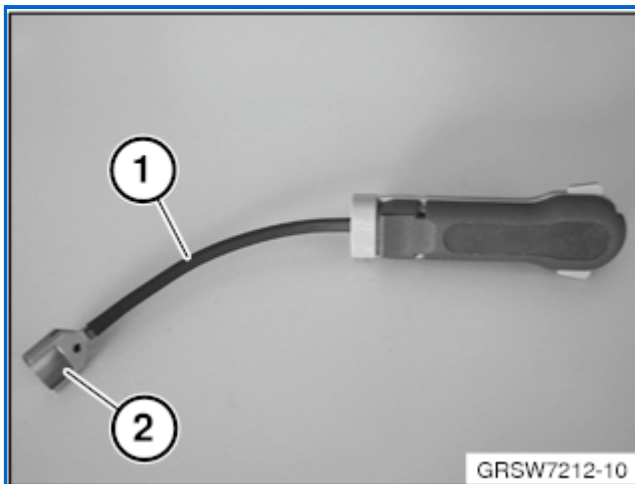

Special tool 72 1 210 for collecting rivet heads.

Shank (1) of special tool is flexible and can be adapted to the relevant body contours.

Note:

Insert butyl in the collecting tray (2) to secure rivet heads and prevent them from falling out.

Insert special tool 72 1 210 through bore hole in body next to attachment points.

Position special tool from rear on rivet head in cavity.

Note:

A second person will be needed to help hold the special tool on the rivet head during the driving-out operation.

Make sure collecting tray is correctly fitted on rivet head.



Drive out stem with hammer and 6 mm punch.

Carefully feed special tool out of body so that rivet head does not fall out of collecting tray.



Note:

If the rivet falls out of the collecting tray into the side frame when the special tool is fed out, this area must be generously filled with foam.

For details of procedure for filling cavities with foam, see further operations.

Use cavity preservation (refer to BMW Parts Department) for foam filling.

Cavity foam (refer to BMW Parts Department) can also be used if necessary.

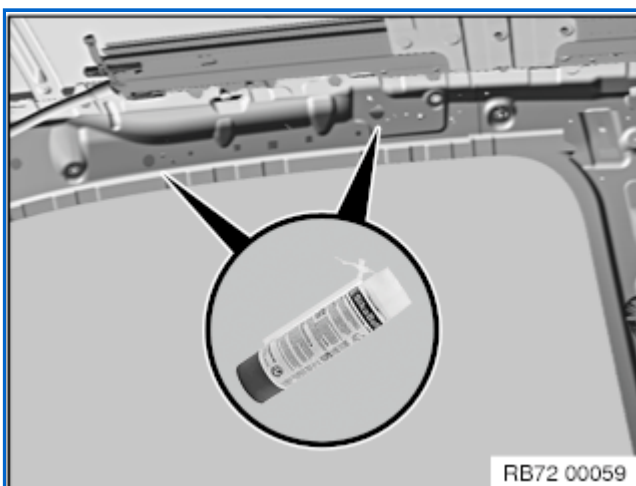

Fit tube to foam can.

Push the hose in through the pillar holes.

Fill cavity with a filling material.

Warning!

Empty foam can completely onto cardboard and after hardening dispose of foam and can in residual waste.

Can may burst if not completely emptied.

Overview of rivet gun:

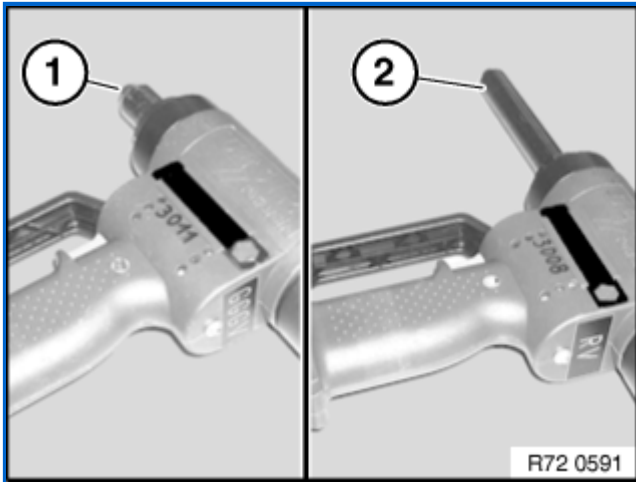

Riveting of gas generator housing and holders for folding pack with rivet gun (refer to BMW Workshop Catalogue).

The interchangeable head is changed for the different work operations.

Riveting of gas generator housing with:

1.) 17/36 nosepiece and short shank

Riveting of holders for folding pack:

2.) 17/40 nosepiece and long shank

REP-REP-RAF1572-7212061 Removing and installing/replacing left or right head airbag
(version with slide/tilt sunroof)

VIN:	0K54831	Vehicle:	X'/F15/off-road vehicle/X5 35iX/N55/AUT/USA/left-hand drive/2014/08
System Version:	3.48.20.13322	Data Version:	R3.48.20.13322

72 12 048

Removing and
installing/replacing
left or right head
airbag (version with
slide/tilt sunroof)

**Important!**

Operations on pyrotechnical devices may only be carried out by authorised experts.

Improper, unauthorised operations may result in serious dangers.

Unauthorized persons are strictly prohibited from performing any operations on this system.

**Warning!**

Read and comply with [safety instructions](#) for handling airbag modules and pyrotechnical belt tensioners.

Incorrect handling can activate airbag and cause injury.

A damaged head airbag must be replaced.

A damaged head airbag exhibits an impaired protective function and in extreme cases loses its protective function altogether.



Note:

Except for the operations for [Removing headlining](#), this task is identical to:

- Removing and installing/replacing left or right [head airbag](#) (version without slide/tilt sunroof)

REP-REP-RAF1572-7212060 Removing and installing or replacing left or right head airbag

VIN:	0K54831	Vehicle:	X'/F15/off-road vehicle/X5 35iX/N55/AUT/USA/left-hand drive/2014/08
System Version:	3.48.20.13322	Data Version:	R3.48.20.13322

72 12 060

Removing and
installing or
replacing left or right
head airbag

Special tools required:

- [72 0 020](#)



Important!

Operations on pyrotechnical devices may only be carried out by authorised experts.

Improper, unauthorised operations may result in serious dangers.

Unauthorized persons are strictly prohibited from performing any operations on this system.



Warning!

Read and comply with [safety instructions](#) for handling airbag modules and pyrotechnical belt tensioners.

Incorrect handling can activate airbag and cause injury.

A damaged head airbag must be replaced.

A damaged head airbag exhibits an

impaired protective function and in extreme cases loses its protective function altogether.



Necessary preliminary tasks:

- Disconnect [battery negative cable](#)
- Remove [headlining](#)
- Follow [notes](#) for unlocking and locking airbag connector connection

Installation overview, retaining elements, head airbag:

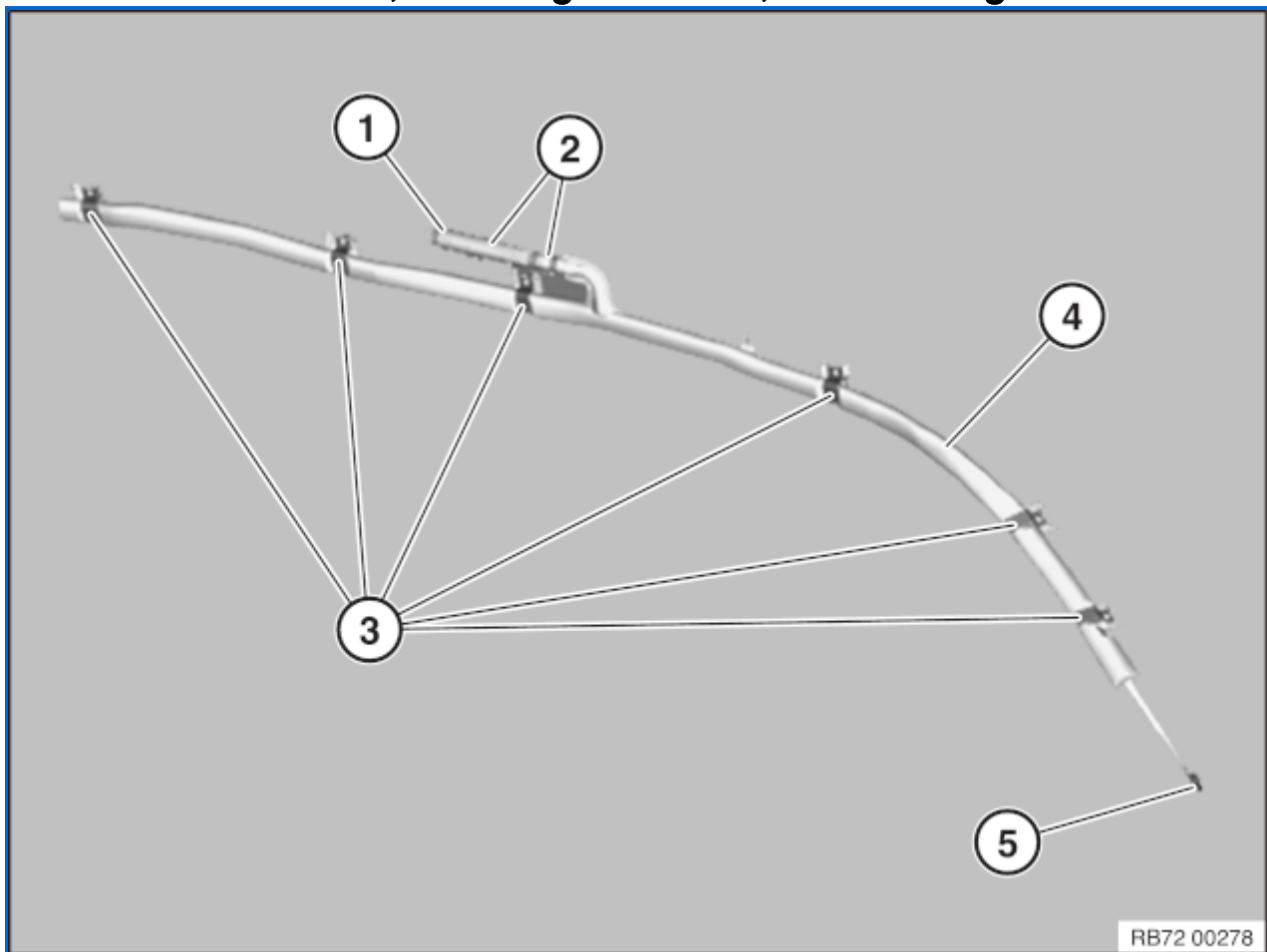

1 Gas generator

2 Rivets for gas generator

3 Retaining clips for folding pack

4 Folding pack, head airbag

5 Rivet for A-pillar end fitting retaining strap

**Important!**

When removing head airbag, do not damage

- Head airbag
- Windscreen
- Holding clips
- Trim panels

Do not damage!

**Important!**

Lay out protective mats to protect the interior against swarf from the drilled-out rivets and damage.

Lay out protective mats in the relevant working area:

- Dashboard
- Entrance area
- Passenger compartment

*Note:*

Note [instructions](#) for the removal of rivets.

To detach the clamps, use special tool [72 0 020](#).

Push the left and right tabs together and pull clamp out.

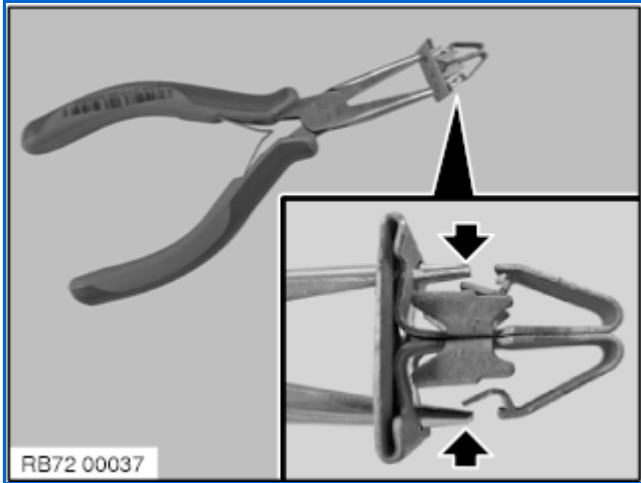

Unlock and remove clamps (1) with flat-nose pliers.

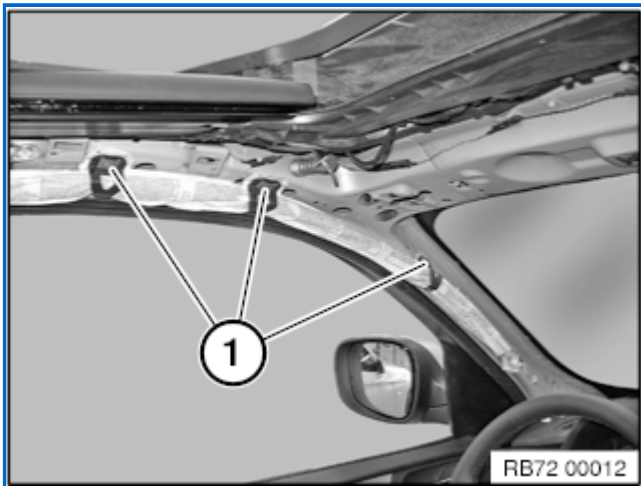

Unlock and remove clamps (1) with flat-nose pliers.

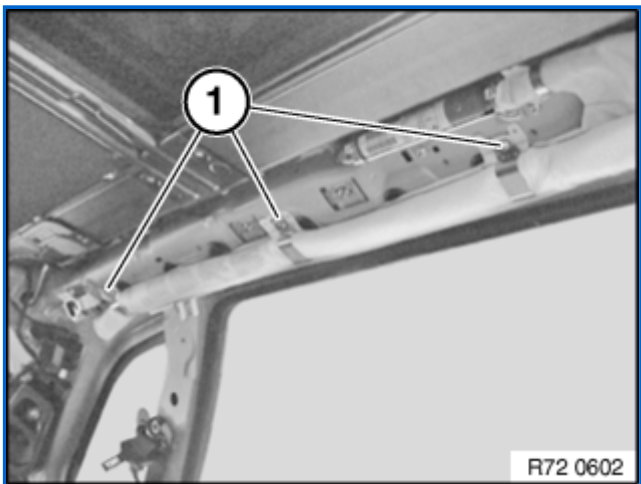

Drill out rivet head (1).

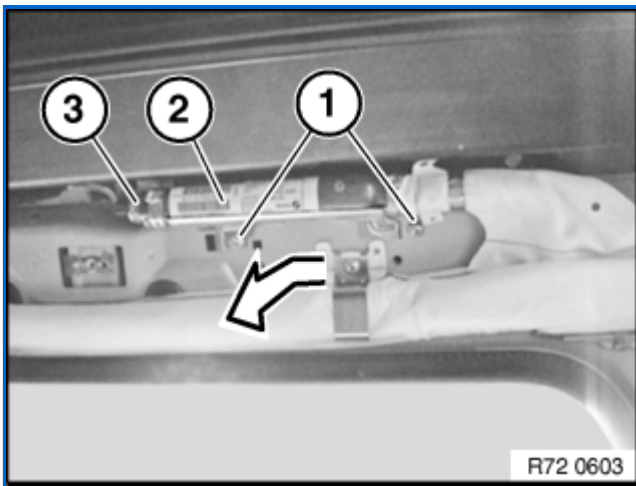
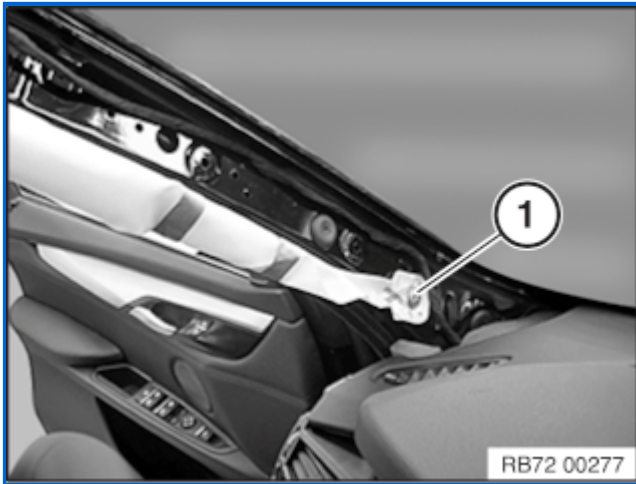

Unlock and disconnect the connector (3) for gas generator (2).

Drill out rivet heads (1).

Remove the gas generator (2) in direction of arrow.

Installation note:

Gas generator is coded against incorrect assembly.