



## Steering Shaft Floor Boot Seal

# RECALL

Models Affected: 2012-2016 Model Year Front Engine/Rear Engine All American/TX3/TX4 Buses

### ISSUE

Clamp on intermediate steering column shaft bellows may contact steering shaft floor boot seal and tear floor boot seal and bind steering shaft causing difficulty in steering.

### CORRECTIVE ACTION

Remove clamp and raise bellows on intermediate steering shaft beyond interference and secure with narrow worm gear clamp.

### PROCEDURE

**WARNING:** Always follow all Federal, State, Local and Shop safety standards and use proper safety equipment, and thoroughly read and understand all instructions before performing these procedures.

1. Park bus on a level surface, apply parking brake, turn off ignition, remove ignition key and chock rear wheels.
2. Inspect steering shaft floor boot seal for wear or damage and slit is toward front of bus.
3. If damaged or worn, complete section **Steering Shaft Floor Boot Seal Replacement** before continuing.
4. After completing section **Steering Shaft Floor Boot Seal Replacement** or if there is no damage or wear to the floor boot seal, complete section **Intermediate Steering Column Shaft Bellows Adjustment**.

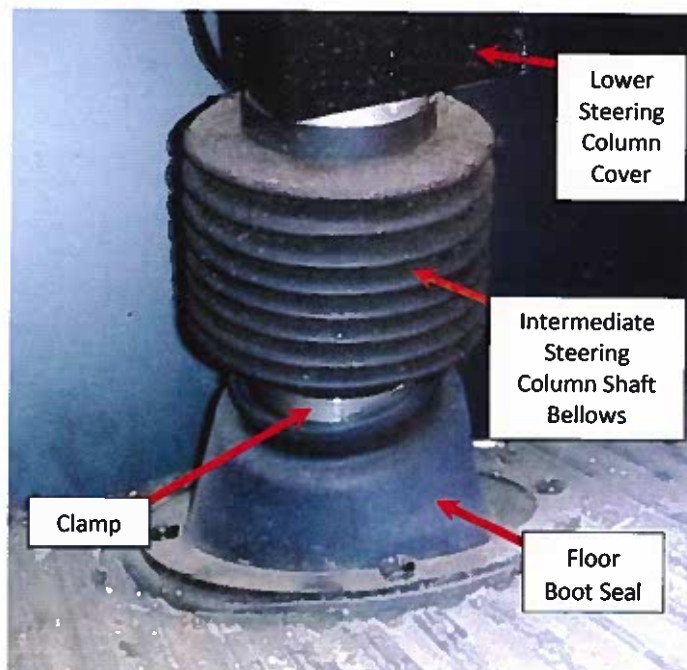

Fig. 1



# Steering Shaft Floor Boot Seal

# RECALL

## Intermediate Steering Shaft Assembly Exploded View

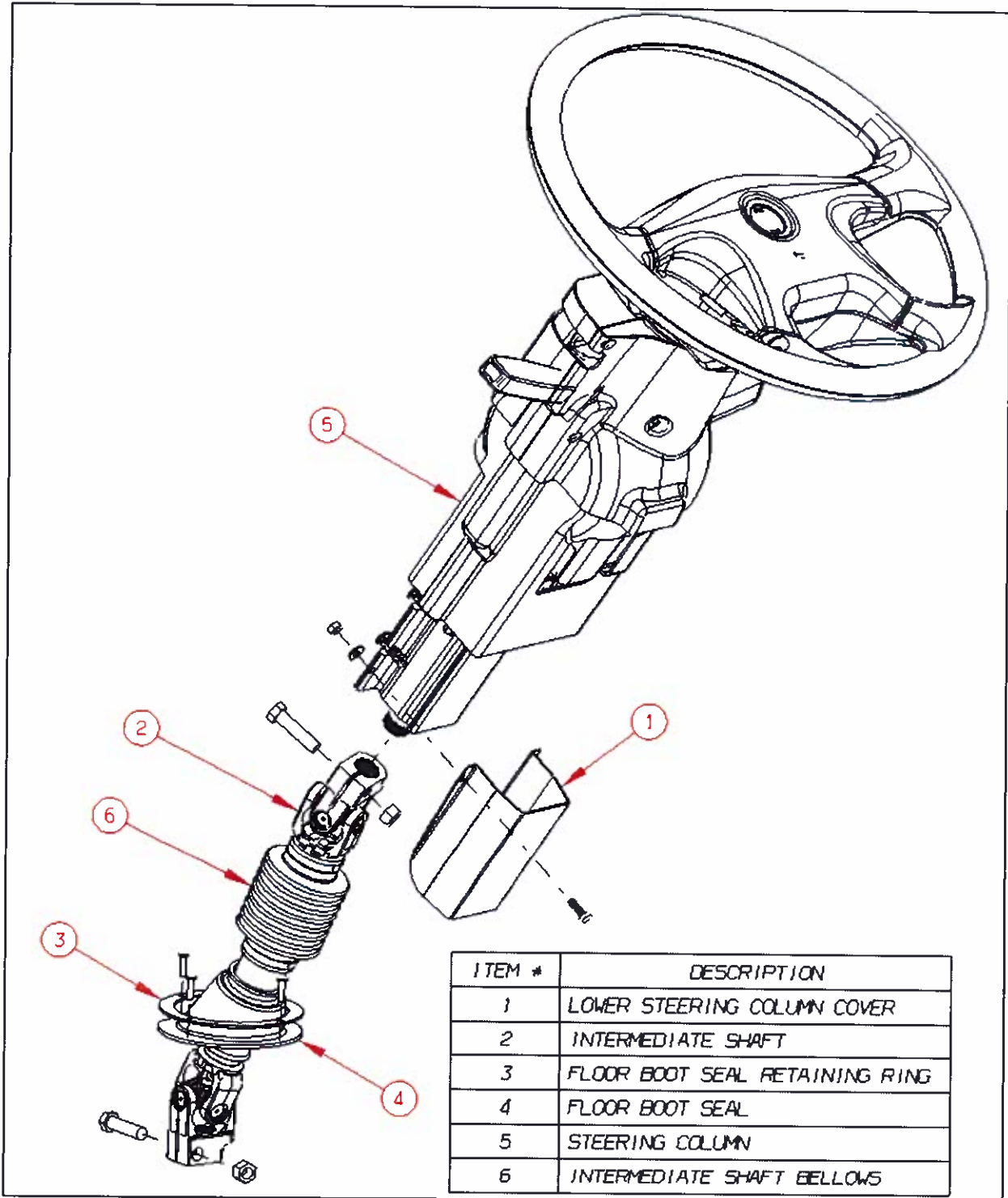

RECALL CAMPAIGN R14XE



## Steering Shaft Floor Boot Seal

# RECALL

### Steering Shaft Floor Boot Seal Replacement (Use exploded view on page 2 for reference)

1. Remove lower steering column cover and discard fasteners. (Fig. 2)
2. Remove four screws from steering shaft floor boot seal retaining ring. Boot seal and retaining ring should be loose from floor. Keep screws for re-use. (Fig. 2)
3. Remove pinch bolt and nut from upper portion of intermediate shaft. Discard bolt and nut. (Fig. 3)
4. Remove pinch bolt and nut from lower portion of intermediate shaft. Discard bolt and nut. (Fig. 3)
5. Compress intermediate shaft together while removing it from splines on steering column and transfer box.
6. Pull intermediate shaft up through hole in floor.
7. Cut off bellows clamp on lower section of intermediate shaft. (See Fig. 3)

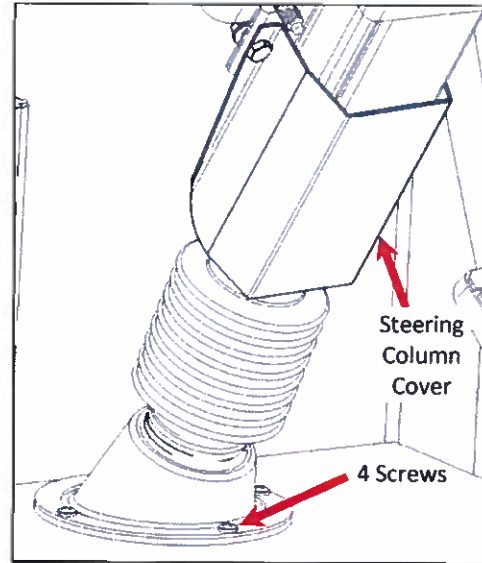

Fig. 2

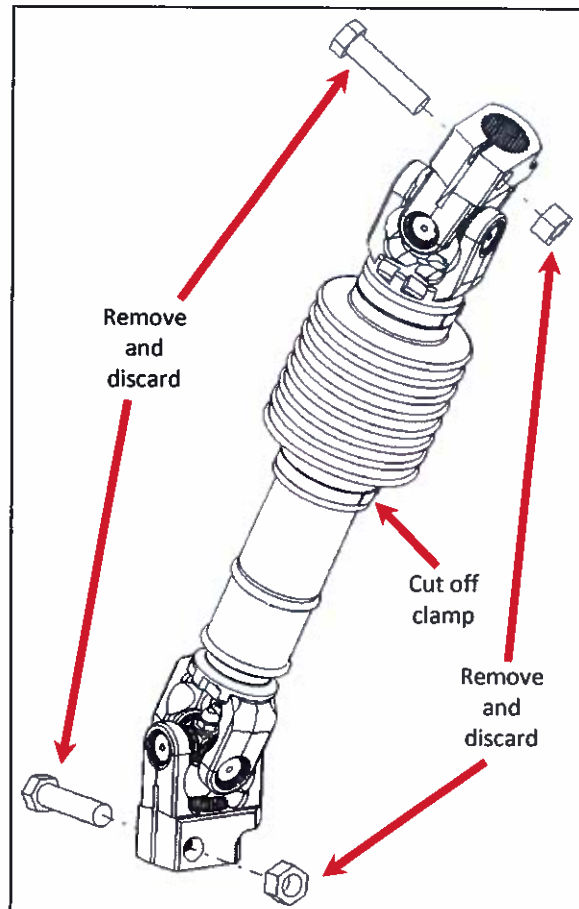

Fig. 3

RECALL CAMPAIGN R I 4 X E



# Steering Shaft Floor Boot Seal

# RECALL

## Steering Shaft Floor Boot Seal Replacement (continued)

(Use exploded view on page 2 for reference)

8. Replace floor boot seal on intermediate steering shaft and re-install intermediate shaft using new fasteners. (See Fig. 4)
  - a. Torque pinch bolts 36-43 FT-LBS.
9. Re-install floor boot seal with retaining ring with four screws. Slit in floor boot seal should be oriented toward front of bus. (See Fig. 5)
10. Install lower steering column cover with new fasteners. (Fig. 6)
  - a. Torque nuts to 37-41 FT-LBS.

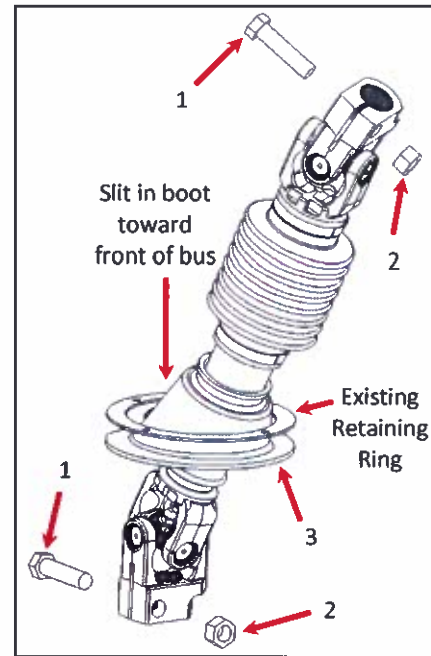

Fig. 4

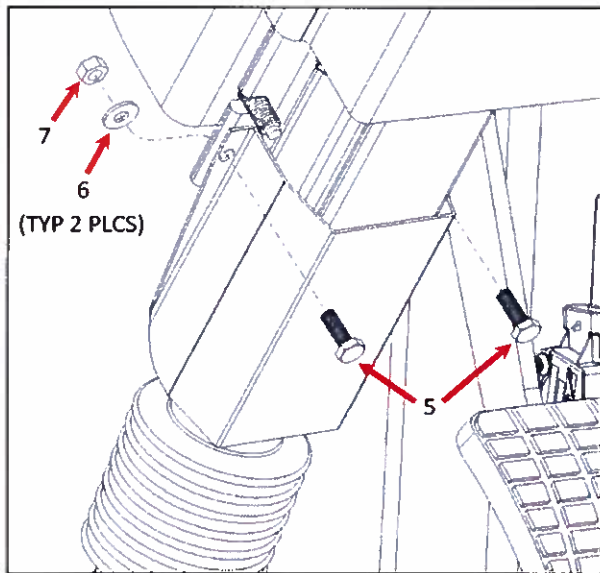

Fig. 6

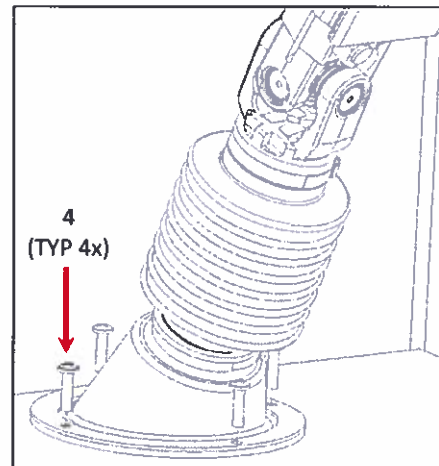

Fig. 5

Parts List for Steering Shaft Floor Boot Seal Replacement			
Item #	Part Number	Description	Qty
1	01916980	CAPSCREW,HEX HD,7/16-14 X 1 3/4,GR8,YELZNDH	2
2	00997080	NUT,HEX HD,7/16-14,LOCKING,GR 8,CADMIUM WAX	2
3	10019820	BOOT,SEAL,STRG SHAFT D3	1
4	01943695	SCREW,10-16X3/4,AB,PH1,PAN HD,BLK ZN	4
5	00977132	CAPSCREW,HEX HD,1/4-20 X 3/4,GR 5,YEL DICH	2
6	01247709	WASHER,FLAT,17/64 ID X 5/8,YEL ZN DICH	2
7	02001345	NUT,HEX HD,1/4-20,LOCKING,YELLOW DICH	2

RECALL CAMPAIGN R14XE



# Steering Shaft Floor Boot Seal

# RECALL

## Intermediate Steering Column Shaft Boot Adjustment

(Use exploded view on page 2 for reference)

1. Cut off bellows clamp on lower section of intermediate shaft if present. (Fig. 7)
2. Push bellows up until it is no longer in contact with steering shaft floor seal boot.
  - a. Minimum 0.50 inch gap between floor seal boot and bellows.
3. Open new worm gear clamp until it releases then secure it around bellows. (Fig. 8)
  - a. New clamp must ride all the way around in groove on bellows.
  - b. Torque clamp to 10-15 in-lb.
4. Inspect the floor boot seal and bellows for minimum 0.50 inch clearance all the way around the intermediate steering column shaft.
5. Recall is complete. Place bus back into service.

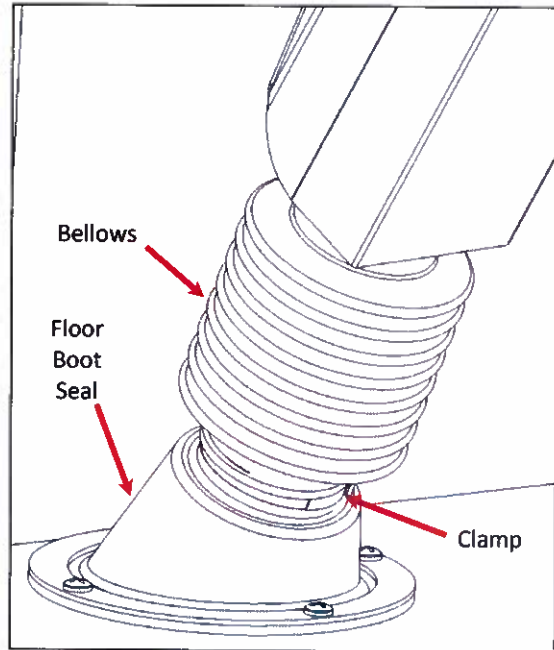

Fig. 7



Fig. 8

Parts List for Intermediate Steering Column Shaft Boot Adjustment			
Item #	Part Number	Description	Qty
8	10039119	CLAMP, WORM GEAR, 2IN, 3524	1

RECALL CAMPAIGN R I 4 X E