



Recall 15V-110

Rear Turn Indicators

R nineT (K21)

Service Information No. SI 63 001 16

Leadership circle

Marketing

Sale
New motorcycles

Sale
Used motorcycles

Aftersales

Administration

Service Information No. SI 63 001 16

Recall 15V-110 Rear Turn Indicators

Situation

During the course of the quality analysis BMW Motorrad has determined that R nineT models produced between 11/2013 and 01/2015 have a slightly shorter set of rear turn indicators stalks than current production. As a result, in certain conditions, the rear turn indicators may be slightly obscured to a driver behind the bike.

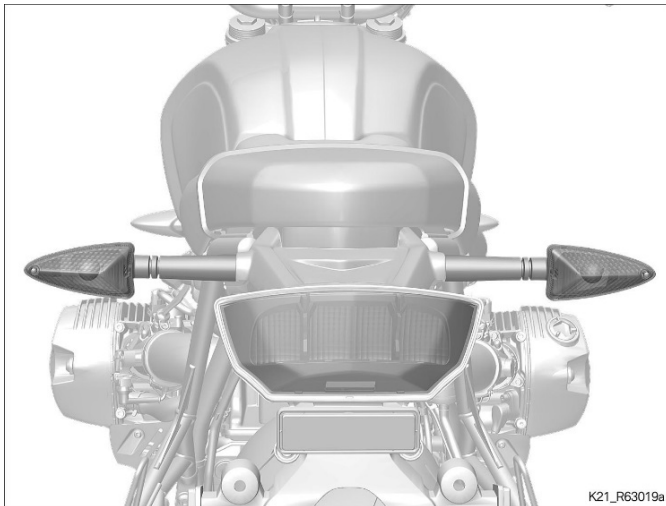

Figure: Motor vehicle with correct rear turn indicators

NHTSA Statement

PERFORM THE PROCEDURE OUTLINED IN THIS SERVICE INFORMATION ON ALL AFFECTED VEHICLES BEFORE CUSTOMER DELIVERY OR THE NEXT TIME THE VEHICLE IS IN THE SHOP FOR MAINTENANCE OR REPAIRS.

BMW Motorcycle dealers must ensure recalls are completed after having been notified by BMW of North America, LLC (BMW Motorrad USA) that a safety-related defect or noncompliance exists in any motor vehicle or item of replacement equipment in the dealer's possession at the time of notification.

In BMW NA's case, this notification would typically be made by the issuance of a recall notification in the form of a Service Information (SI) bulletin or transmission of a Dealer Communication System (DCS) recall message.

Under the National Traffic and Motor Vehicle Safety Act of 1966, as amended, if a recall campaign is announced by BMW NA, dealers must ensure that all recalls on vehicles and new items of replacement equipment are completed BEFORE delivery to the consumer. This means that dealers may not legally deliver new vehicles or new items of replacement equipment to consumers with an open recall.

The Safety Act also prohibits dealers from selling or leasing the vehicle or item of replacement equipment, unless and until the open recall has been completed BEFORE delivery. This also pertains to motorcycles in the Certified Pre-Owned program, and to items of replacement equipment.

Finally, BMW motorcycle dealers should not sell or use parts that have been recalled by BMW Motorrad USA.

Please follow the specific instructions provided by BMW Motorrad USA on the return or disposition of the parts.

Vehicles affected

In order to determine if a specific vehicle is affected by this Technical Campaign, it will be necessary to verify all vehicle VINs through a DCS Vehicle History Check. Based on the response of the system, either proceed with the repair or take no further action. Please note, affected VINs may not appear until 24-72 hours after the release of this bulletin.

Production solution

As of January 27, 2015, turn indicators that comply with statutory requirements are installed.

Aftersales solution

All vehicles affected by this issue must have turn indicators that comply with statutory requirements installed.

The rear turn indicators are to be renewed according to work item 63 23 012 and 63 23 510.

The work items can be seen in AIR (Aftersales Information Research) and on the current RSD (Repair and Service Data BMW Motorrad) service data DVD.

Service Information No. SI 63 001 16

Recall 15V-110 Rear Turn Indicators

Warranty processing

Defect code

00 63 04 00 00	Renewing the rear turn indicator
----------------	----------------------------------

FRU numbers

63 23 012	Replacing left rear turn indicator, 3 FRUs
+63 23 510	Replacing right rear turn indicator, 2 FRUs

Part numbers

63 13 8 534 354	1x Turn Indicator
63 13 8 534 355	1x Turn Indicator

Questions regarding this bulletin?

For technical inquires in relation to this bulletin	Please contact the PuMA team
For warranty inquires in relation to this bulletin	Motorrad.Warranties@bmwna.com
For parts inquires in relation to this bulletin	Adam.Sacher@bmwnaext.com
Motorcycle Service and Technical Manager	Gordon.McDonnell@bmwna.com
Bulletin authored/published by	Gery.Torok@bmwna.com