



# Potential for Rear Engine Exhaust Hangers Failing

(Revised December 7, 2015)

# RECALL

**Models Affected:** Certain Rear Engine All American Buses with a Selective Catalytic Reduction (SCR) and Diesel Particulate Filter (DPF).

## ISSUE

The rubber SCR and DPF hanger strap assembly may fail under extreme conditions causing extensive damage to the SCR and DPF modules.

## CORRECTIVE ACTION

Install new exhaust hanger strap assembly 10040843 (4 Places); and exhaust support cables, 10047279.

## PROCEDURE

### WARNING:

Always follow all Federal, State, Local, and Shop safety standards and use proper safety equipment, and thoroughly read and understand all instructions before performing these procedures.

### CAUTION:

Allow exhaust system to cool prior to performing these procedures to prevent the risk of severe burns.

1. Park the bus on a level surface, apply parking brake, turn off engine, remove ignition key, and chock wheels.
2. Locate the four muffler hanger strap assemblies supporting the SCR and DPF at the rear of the bus.

Note: Inspect welded Main Support Brackets for damage (bent brackets or cracked welds) before installing new muffler hanger bracket assemblies. Replace, as needed.

3. Support the SCR and DPF, and replace muffler hanger strap assemblies (4 Places) with new assemblies 10040843 and add two exhaust support cables 10047279, two bolts 00803171, two nuts 00543934, and two nuts 02171809 per exhaust hanger strap assembly. Drill out slots at eight (8) mounting locations to 13/32 inch diameter. Do not reuse old nuts.

Torque upper 3/8" nut that comes with new bracket assembly 10040843 to 72 – 78 in-lb.

4. Torque lower 3/8" nuts (00543934 and 02171809) to 29 - 33 lb-ft. See Sheet 2 for illustration.

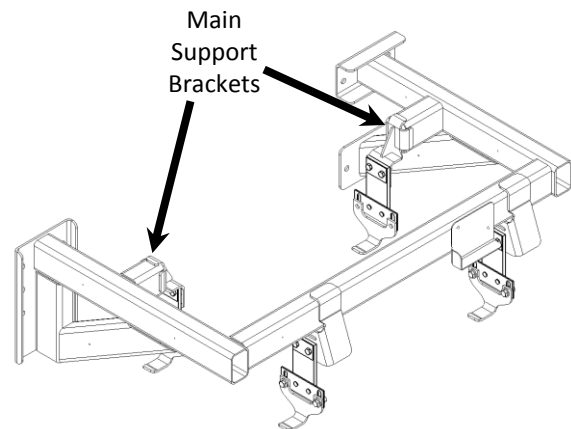
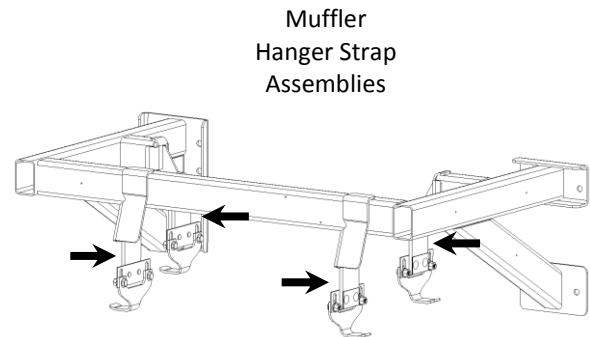

RECALL CAMPAIGN - R I 5 Y B



**Potential for Rear Engine Exhaust Hangers Failing**  
 (Revised December 7, 2015)

RECALL

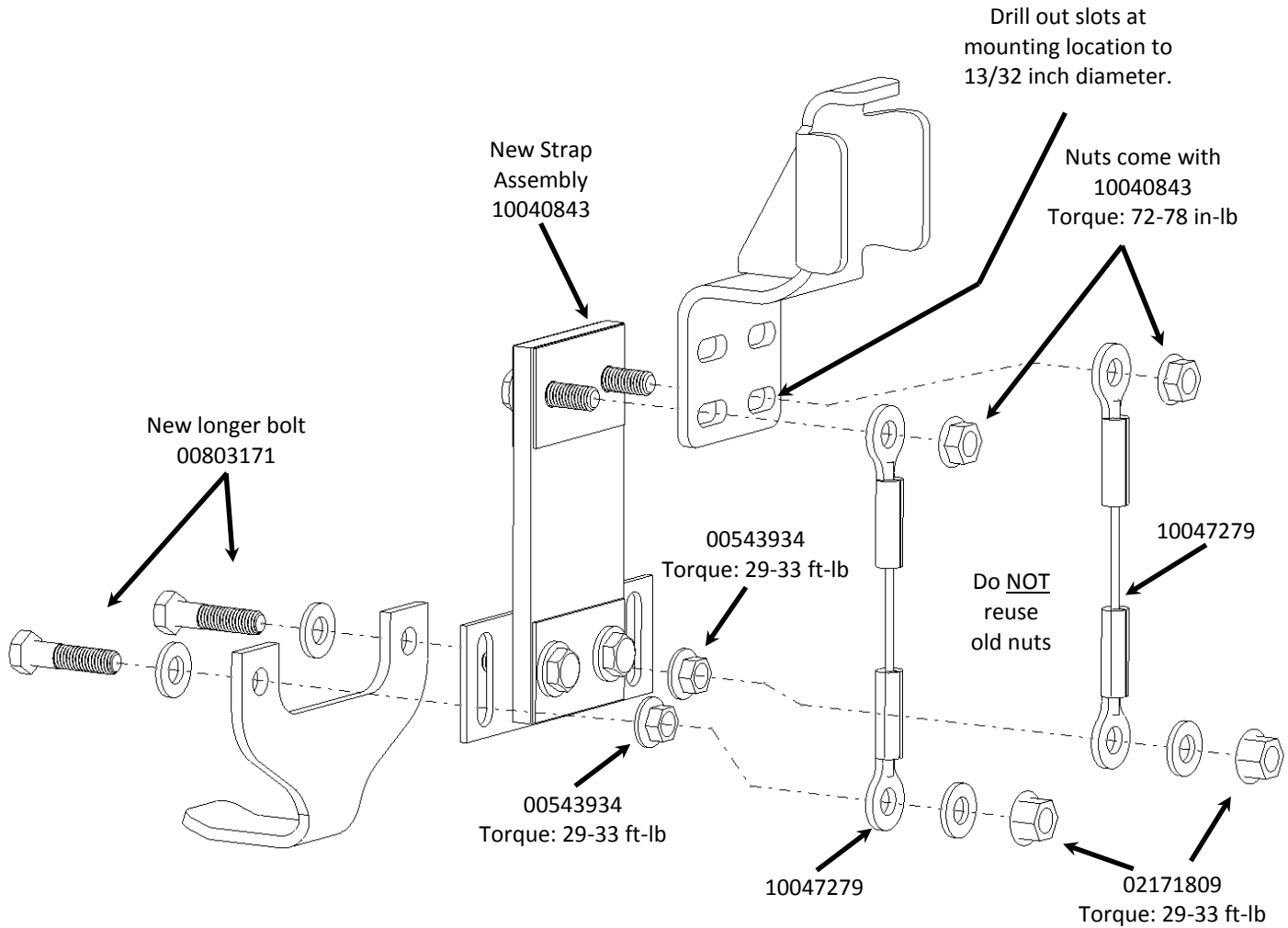

Parts List		
Part #	Description	Qty
10047279	CABLE ASSY, SUPPORT,6.00",EXHAUST, T3RE	8
10040843	BRACKET ASSY,EXH,HANGER,ADJUSTABLE,5.63	4
02171809	NUT,HEX HD,3/8-16,SM FLG LK	8
00543934	NUT,HEX HD,3/8-16,ZINC,LG FLG LK, YEL ZNDICH	8
00803171	CAPSCREW,HEXHD,3/8-16NCX1-1/2,GR8,YELZNDICH	8

Note: Re-use existing washers.

R I S Y B  
--RECALL CAMPAIGN--