

SAFETY RECALL

Mack Trucks Inc.
Greensboro, NC USA



Date 03.2015 Number **SC0388** Release **01** Page 1 (7)

Door Handle, Inside LEU

SAFETY RECALL INFORMATION:

(March 2015)

Because of stack-up tolerances, the actuator tab may be too short, which can allow the end of the actuator tab to slide behind the inner door latch. If this occurs, the driver may not be able to open the door from inside the truck, which under certain circumstances may increase the risk of injury. To reduce the potential risk of injury, replacement of the left and right inside door handles will be necessary.

Mack Trucks has received no reports of personal injury as a result of this condition. Therefore, Mack considers this as a proactive measure to protect the public and Mack's customers from the potential risk associated with this defect.

VEHICLES AFFECTED:

Certain 2015 MACK LEU model vehicles manufactured from March 31, 2014 through December 12, 2014.

VEHICLE IDENTIFICATION NUMBERS (VIN):

The number of vehicles affected by this recall is 790 (734 USA, and 56 Canada).

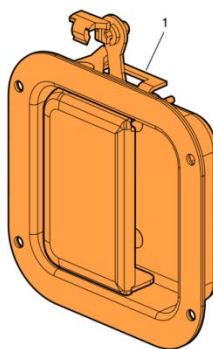

Required Parts:

To order parts call (877) 986-5862. The Vehicle Identification Number (VIN) is required for ordering parts.

PART NUMBER	QTY	DESCRIPTION
82792311	1	Door Handle, Inside, Left
82792312	1	Door Handle, Inside, Right

Decommissioning the Truck for Inspection or Repair:

1. Secure the vehicle for service by parking on a flat and level surface, applying the parking brake, chocking the rear wheel, and placing the transmission in neutral.

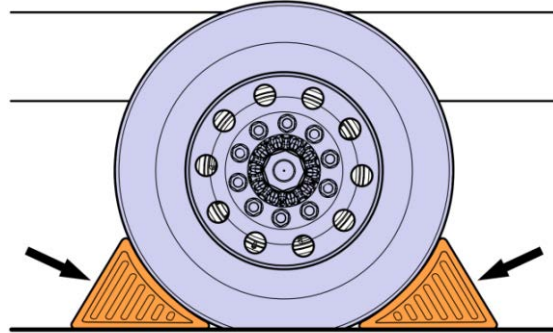

2. Disconnect the cable from the battery's negative (ground) terminal.

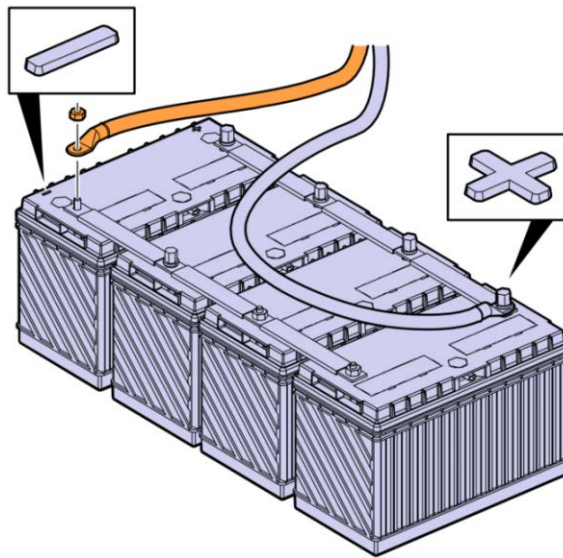

Inside Door Handle Replacement Procedure:

NOTE

The Illustrations shown in this document are used for reference only and may differ slightly from the actual vehicle being serviced. However, the replacement procedure represented as accurately as possible.

1. Open the door to gain access to the inside door handle.
2. Remove the inside door handle fasteners.

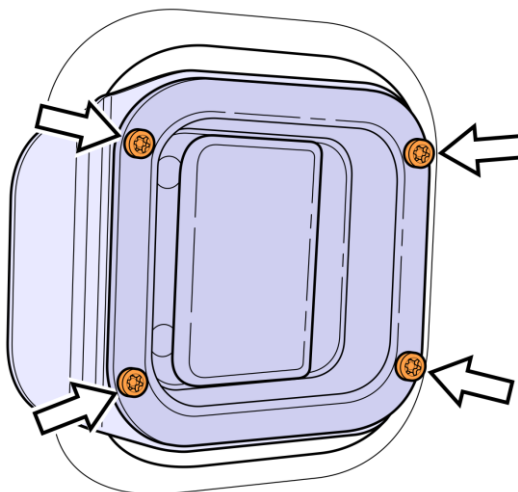

3. Pull the inside door handle away from the door to gain access to the door handle latch and linkage.

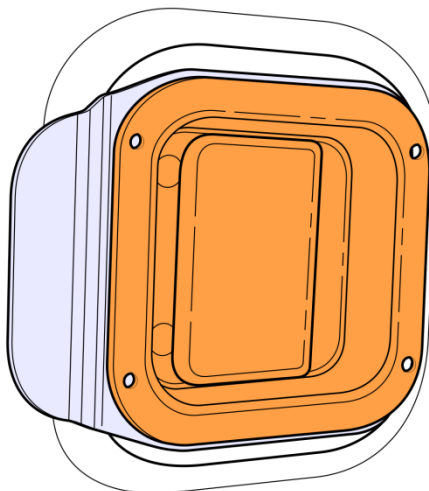

4. Using locking pliers, clamp the linkage connected to the inside door handle latch to prevent the linkage from falling inside the door.
5. Remove the linkage from the inside door handle latch.

NOTE

Leave the locking pliers clamped to the linkage for installation of the replacement inside door handle.

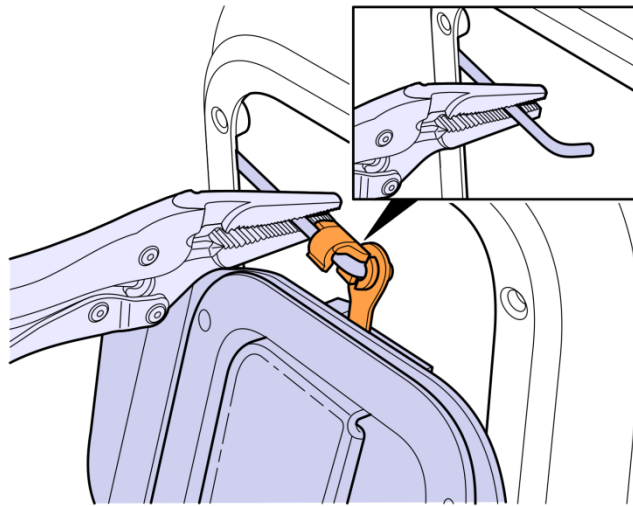

6. Connect the linkage to the inside door handle latch.
7. Remove the locking pliers.

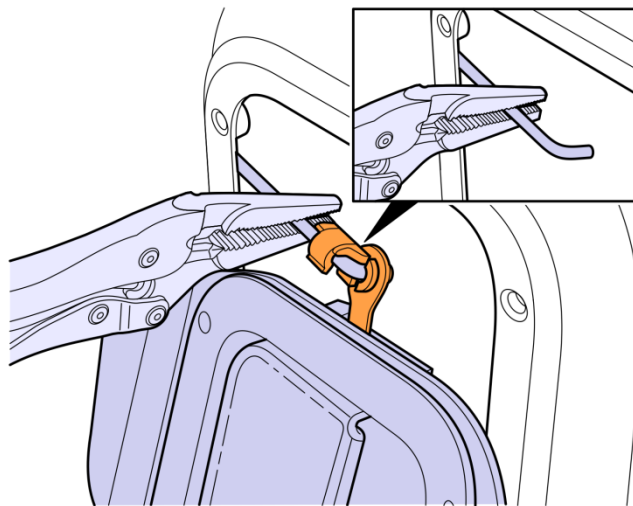

8. Position the inside door handle as shown in the illustration below.

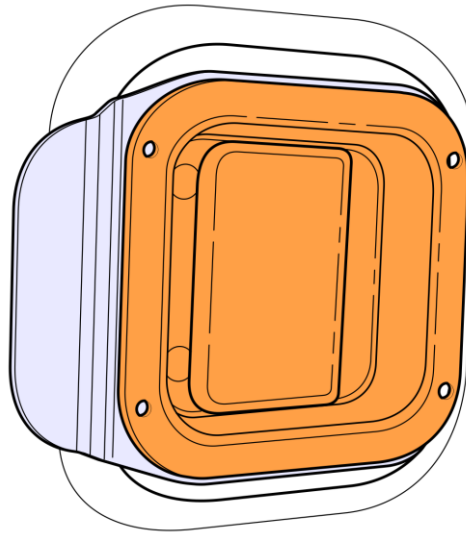

9. Install the fasteners securing the inside door handle.

10. Using hand tools, tighten the fasteners securing the inside door handle.

NOTE
Do not over tighten the fasteners securing the inside door handle.

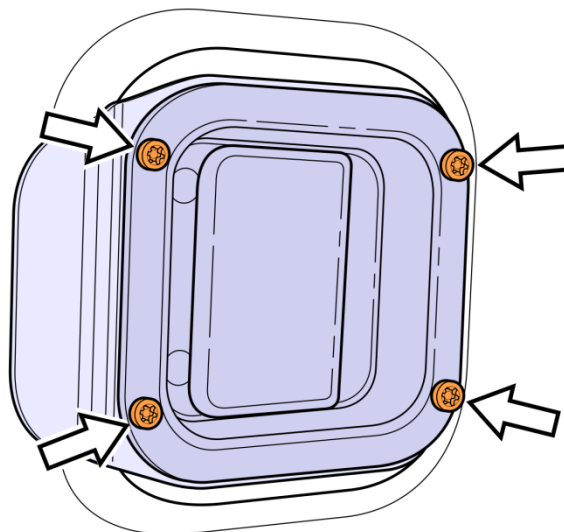

Commissioning the Truck for Operation:

1. Connect the battery cable to the negative (ground) terminal.

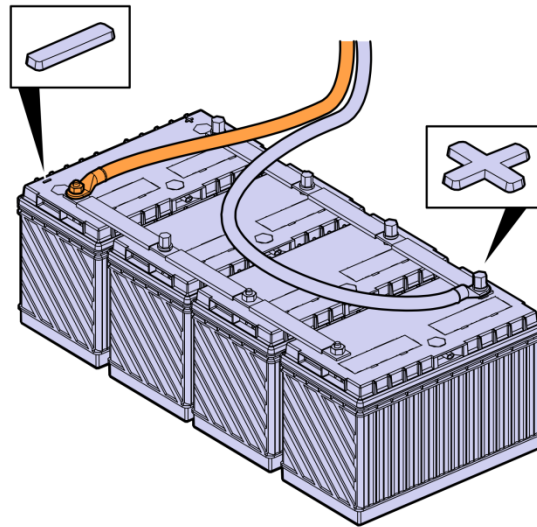

2. Remove the wheel chocks.

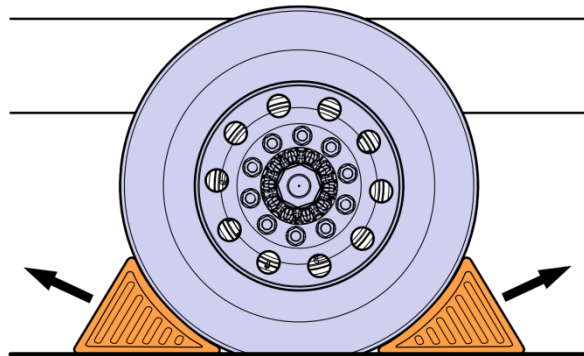

REIMBURSEMENT:

This repair is covered by an authorized Safety Recall campaign. Reimbursement is obtained through the normal claim handling process.		
	UHP Reimbursement	eWarranty Reimbursement
Claim Type (Used when uploading from the Dealer business System)	40	40
Recall Status		
Vehicle repaired per instructions		1-Modified per instructions
Labor Code		
Primary Labor Code (Inside Door Handle, Replacement), Both Doors	8345-03-09-01 0.3 hrs	6271A-ZV-95 0.3 hrs
Time to take charge of vehicle and determine campaign status	1700-16-01-01 0.3 hrs	101AA-0A-00 0.3 hrs
Causal Part	84161480, 84161481	84161480, 84161481
Authorization Number	C6556	SC0388

Take-charge time is not included in the labor code for this operation. Take charge may be eligible, but can only be used once per vehicle repair visit. If the vehicle is having other warranty repairs performed, take-charge should be charged to the warranty repair, otherwise take-charge can be charged to this Safety Recall campaign.