

## Reference:

ITB15-008a

## Date:

March 27, 2015

## VOLUNTARY SAFETY RECALL CAMPAIGN 2008 EX AND 2009 FX STEERING COLUMN UPPER BEARING

This bulletin has been amended to provide additional information on the shaft spline alignment and to add the owner's letter and NHTSA number. Please discard the previous version.

CAMPAIGN ID #: R1501  
NHTSA #: 15V-054  
APPLIED VEHICLES: 2008 EX35 (J50)  
2009 FX35/FX50 (S51)

**Check Service COMM to confirm campaign eligibility.**

### INTRODUCTION

Infiniti is conducting a Voluntary Safety Recall Campaign on certain specific Model Year 2008 EX and 2009 FX vehicles to replace the steering column "shaft and tube" assembly. This service will be performed at no charge for parts or labor.

### IDENTIFICATION NUMBER

Infiniti has assigned identification number R1501 to this campaign. This number must appear on all communication and documentation of any nature dealing with this campaign.

### RETAILER RESPONSIBILITY

It is the retailer's responsibility to check Service Comm for the campaign status on each vehicle falling within the range of this voluntary safety recall which for any reason enters the service department. This includes vehicles purchased from private parties or presented by transient (tourist) owners and vehicles in a retailer's inventory. **Federal law requires that new vehicles in retailer inventory which are the subject of a safety recall must be corrected prior to sale. Failure to do so can result in civil penalties by the National Highway Traffic Safety Administration.** While federal law applies only to new vehicles, Infiniti strongly encourages retailers to correct any used vehicles in their inventory before they are retailed.

Infiniti Bulletins are intended for use by qualified technicians, not 'do-it-yourselfers'. Qualified technicians are properly trained individuals who have the equipment, tools, safety instruction, and know-how to do a job properly and safely. NOTE: If you believe that a described condition may apply to a particular vehicle, DO NOT assume that it does. See your Infiniti retailer to determine if this applies to your vehicle.

## SERVICE PROCEDURE

**IMPORTANT:** Follow all cautions, warnings, and notes in the Electronic Service Manual (ESM) when working on or near a Supplemental Restraint System (SRS), such as an air bag.

**CAUTION:** Handle interior trim carefully to avoid damage. Work with clean hands and clean tools to avoid dirt and stains. Use protective covers as needed.

1. Remove the steering column assembly from the vehicle.
  - Refer to the Electronic Service Manual (ESM), section ST-Steering System, for steering column removal information. Make sure to reference Steering Column With Electric Motor.
  - During steering column removal, make sure the steering column is adjusted to the highest level (all the way UP) and the longest level (all the way out toward the driver).
2. Place the steering column assembly in a clean working area.

3. Remove the lock bolt from the upper joint.
4. Remove the upper joint.

**NOTE:** This upper joint will be reused – re-installed at the end of the procedure.

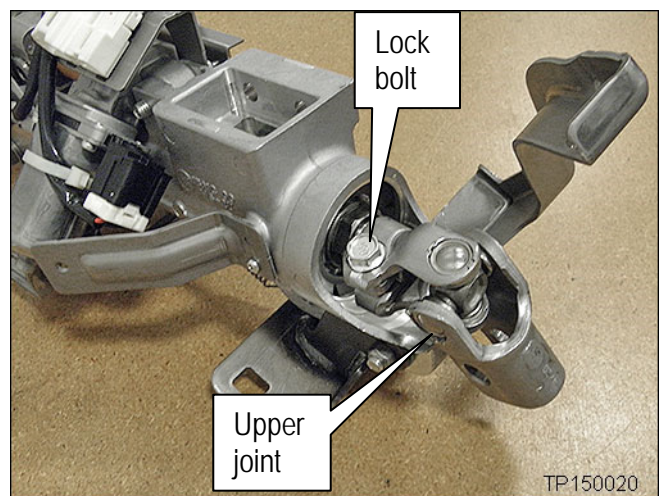

Figure 1

5. Remove the hex nut from the end of the steering column.
  - Use a wrench or other suitable tool to hold the steering lock gear while removing the nut (see Figures 2 and 3).

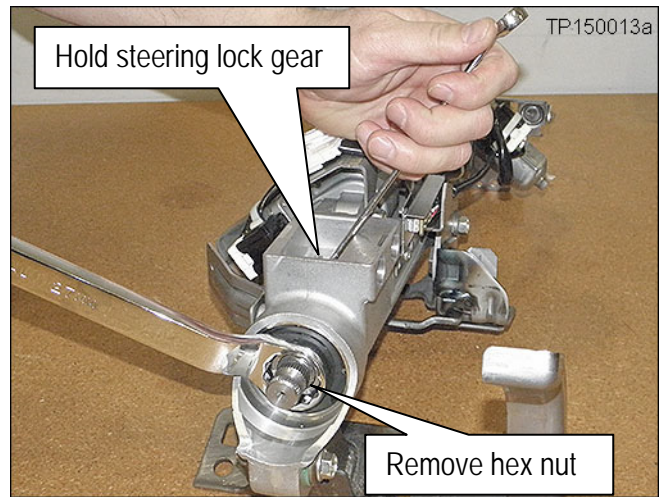

Figure 2

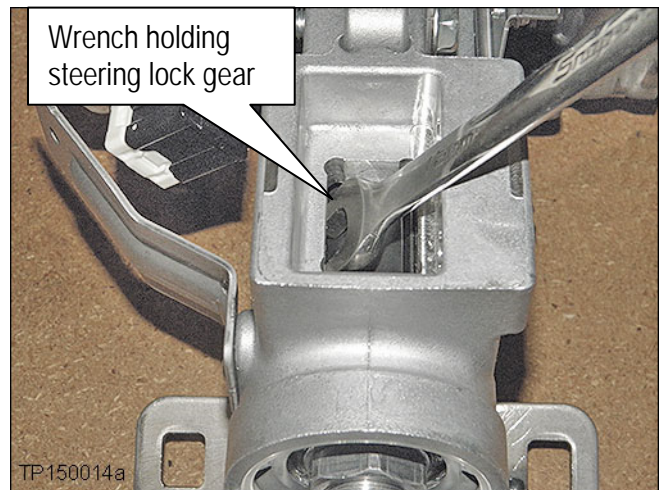

Figure 3

6. Remove the harness bracket.
  - a. Remove bolt with nut shown in Figure 4.
  - b. Remove harness bracket.

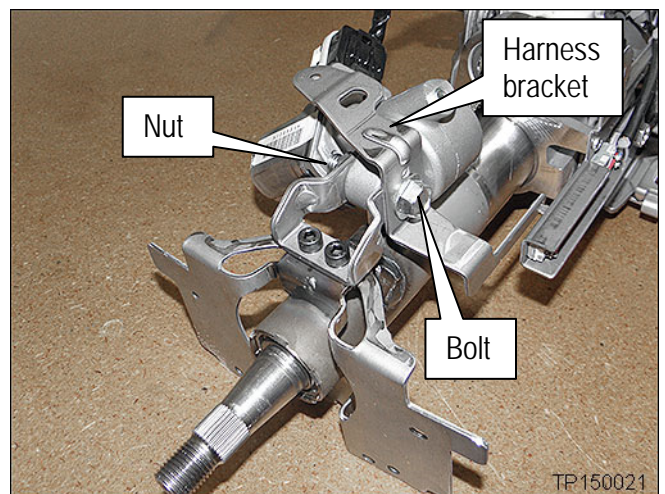

Figure 4

7. Remove the telescope motor support bracket.
  - a. Remove 2 bolts shown in Figure 5.
  - b. Remove the telescope motor support bracket.

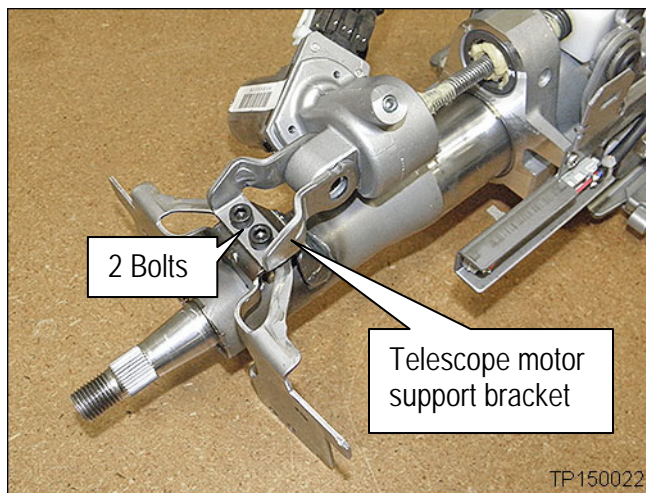

Figure 5

**CAUTION:**

- With the telescope motor support bracket removed, the telescope motor is not supported.
- During this Service Procedure you will need to reposition the steering column assembly several times.
- Use care while repositioning the steering column assembly. Do **not** put pressure on the telescope motor and screw.

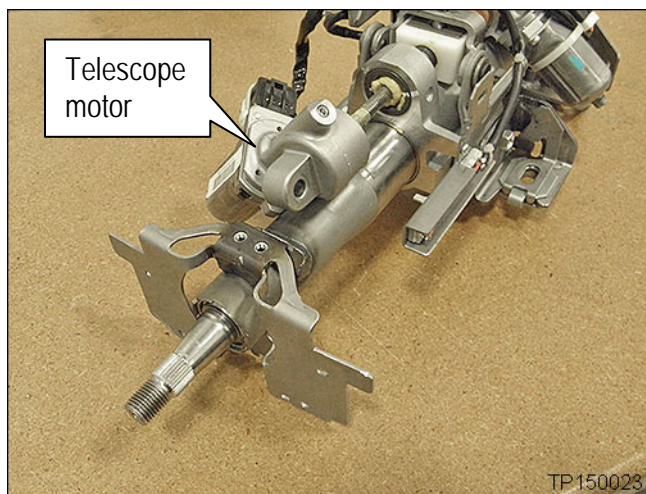

Figure 6

8. If equipped: Remove the paddle switch bracket.
  - a. Remove 2 screws shown in Figure 7.
  - b. Remove the paddle switch bracket.

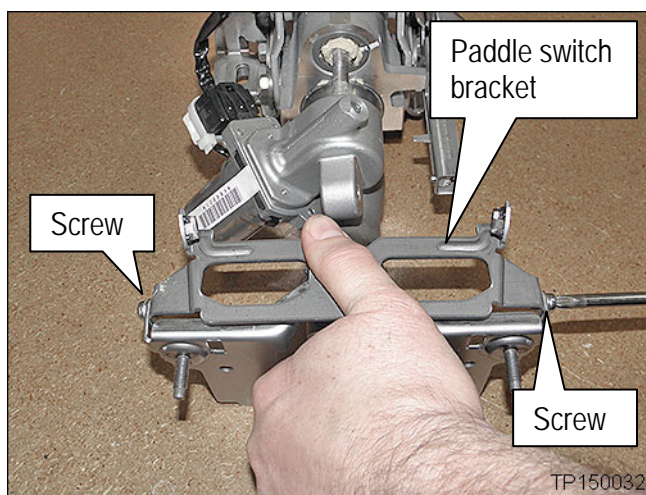

Figure 7

9. Remove the telescope stopper bolt.

10. Remove the slide pad retainer.

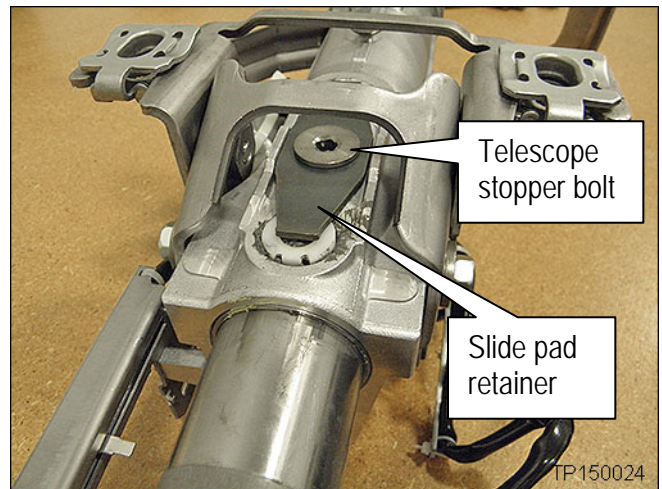

Figure 8

11. Remove the 2 slide pads.

- The slide pads lift out of the holes. A small tool may be helpful in lifting/removing the slide pads.

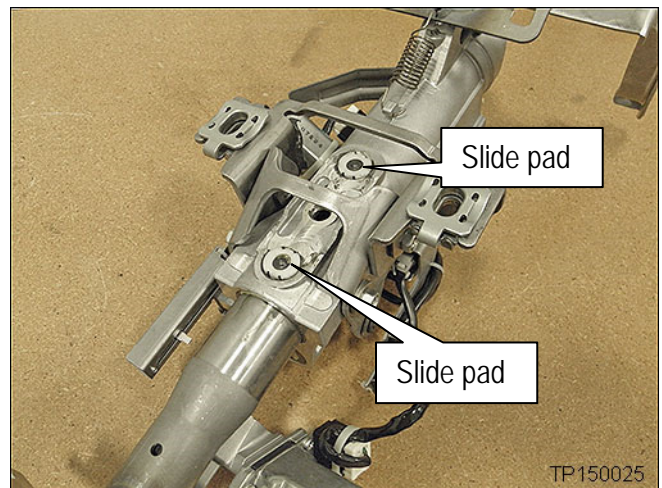

Figure 9

12. Remove (pull) the "shaft and tube" assembly from the steering column assembly.

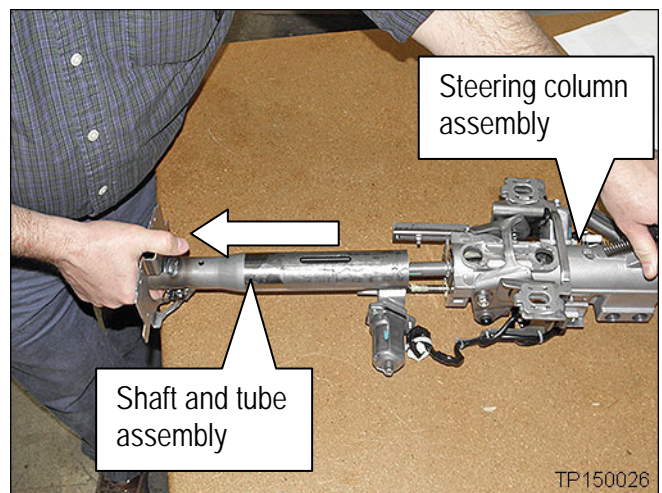

Figure 10

**IMPORTANT:** In the following steps insure that the sliding shaft portion of the new "shaft and tube" assembly (Figure 11) is not removed from the tube. If the shaft is separated, refer to the information and Figure 33 on page 15 to reassemble.

13. Prepare the new 'shaft and tube' assembly for installation.

- a. Remove tape from each end of the shaft.
- b. Apply KEY LOCK grease (yellow tube included with steering column kit) to each tooth on the steering lock gear.

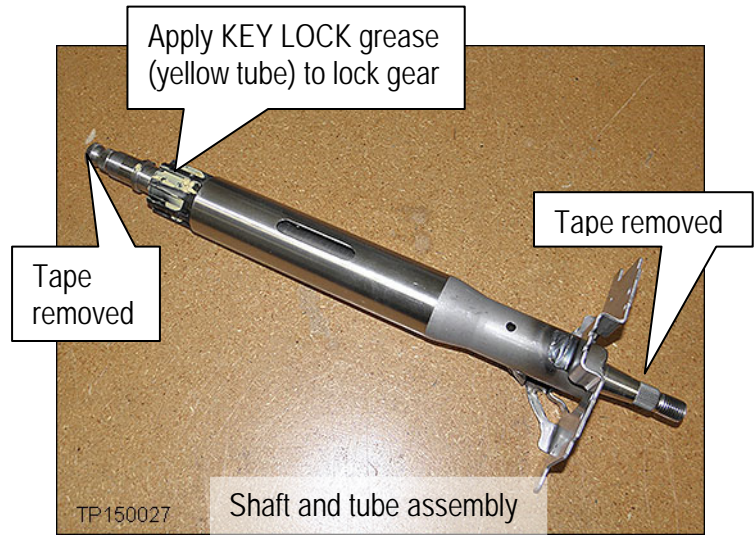

Figure 11

14. Install the new "shaft and tube" assembly into the steering column assembly.

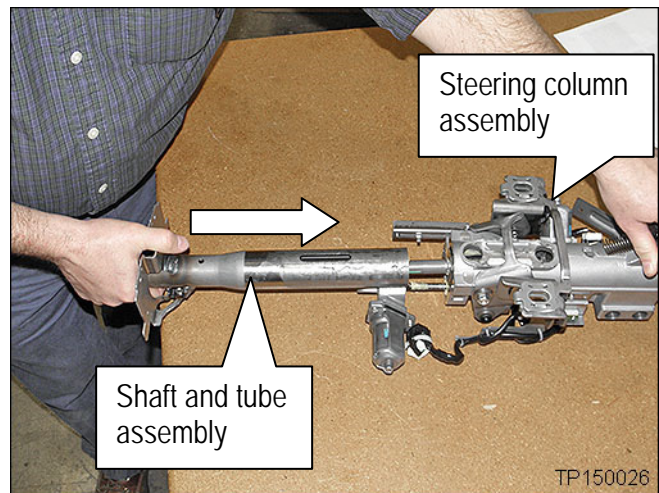

Figure 12

15. Install the hex nut, finger tight, on the upper joint end of the shaft.

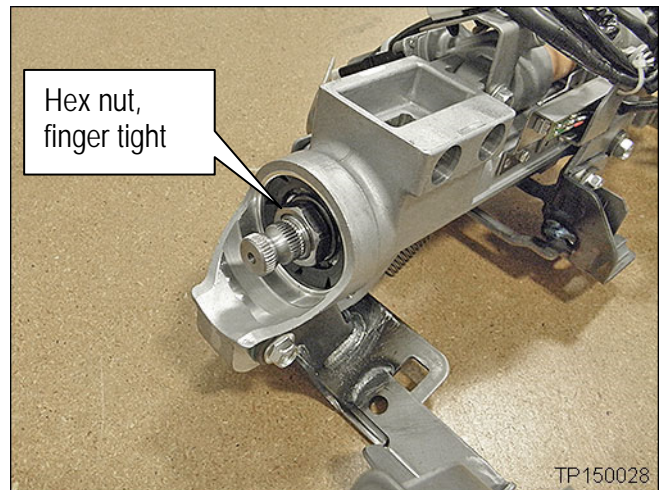

Figure 13

16. Apply UPR TUBE grease (white tube included with steering column kit) as follows:
- Apply grease on tube through both slide pad holes.
  - Rotate tube about  $\frac{1}{4}$  turn.
  - Apply grease on tube again, through both side pad holes.
  - Repeat b and c above 3 times.
  - Rotate the "shaft and tube" assembly a few times to spread the grease.
  - Push/pull the "shaft and tube" assembly in and out a few times to spread the grease.



Figure 14

17. If equipped: Re-install the paddle switch bracket. Torque screws to:  
 $3.2 \text{ N}\cdot\text{m}$  (0.32 kg-m, **28 in-lb**)

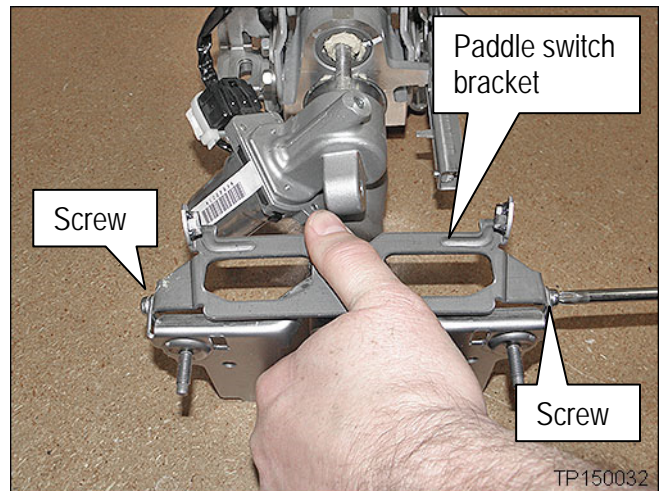

Figure 15

18. Re-install the telescope motor support bracket. Torque bolts to  $8 \text{ N}\cdot\text{m}$  (0.81 kg-m, **71 in-lb**)

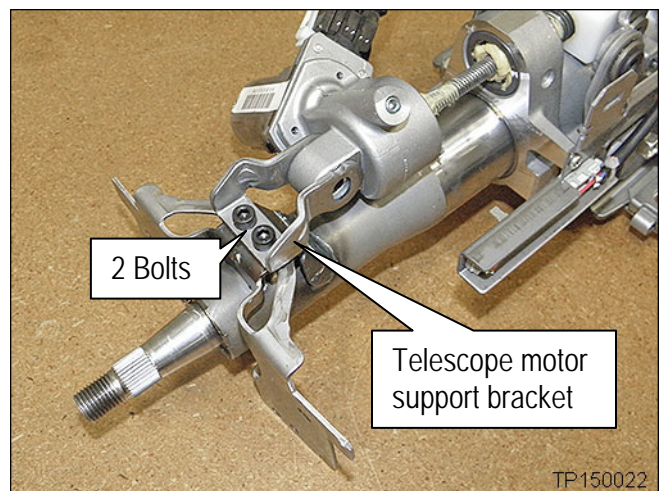

Figure 16

19. Re-install the harness bracket as follows:

- a. Align bolt hole on the telescope motor with bolt hole on the telescope motor support bracket.

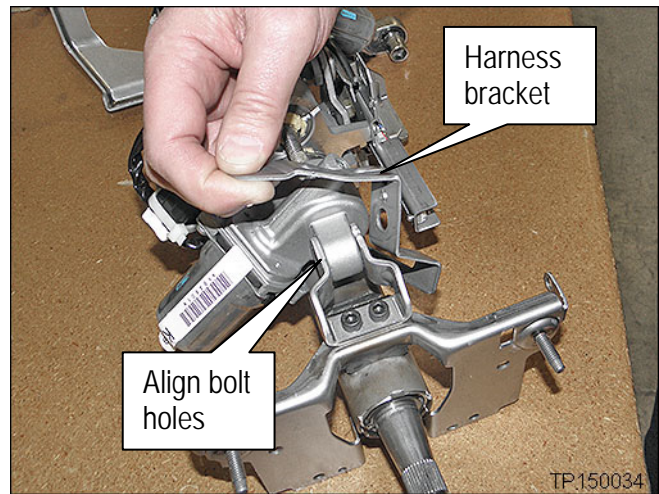

Figure 17

- b. Align tab on the harness bracket with the notch in the telescope motor support bracket.

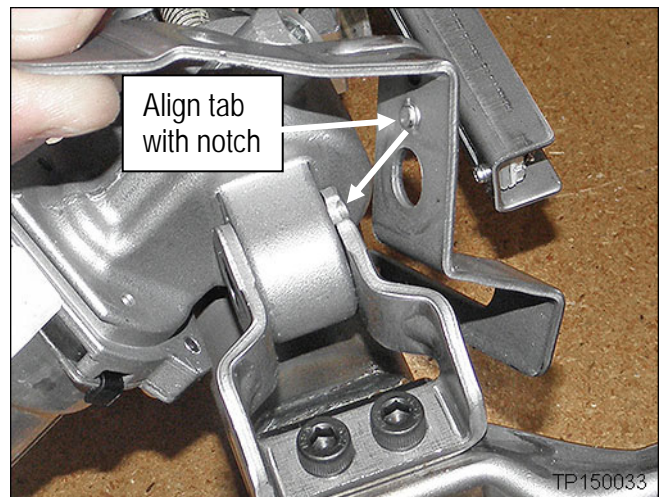

Figure 18

- c. Make sure the finger on the tilt sensor is in the hole/slot on the harness bracket.

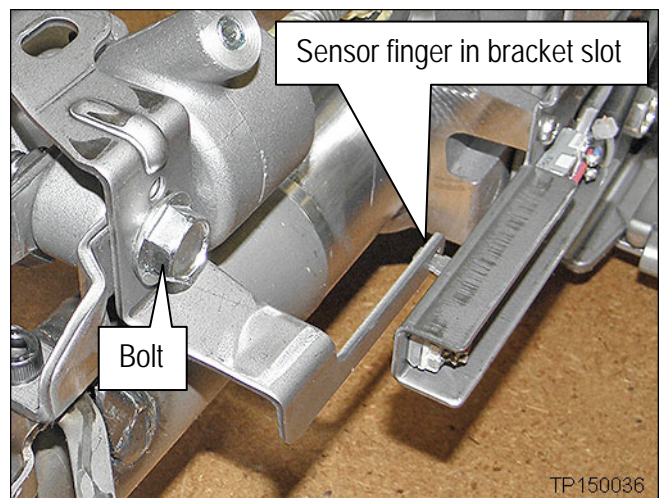

Figure 19



- d. Install bolt and nut and torque to:  
18 N•m (1.8 kg-m, 13 ft-lb)

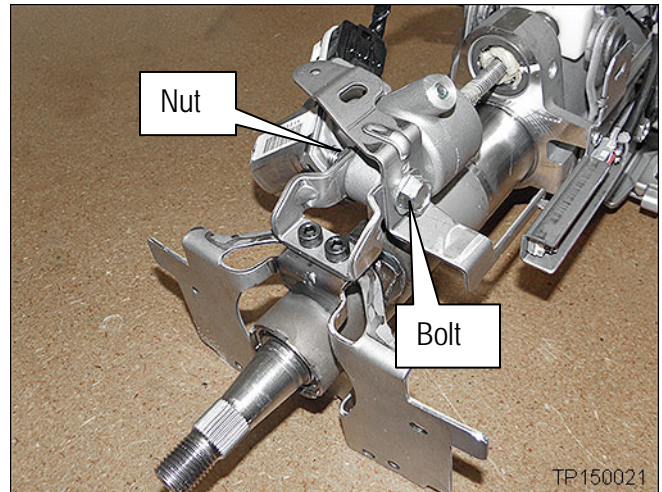

Figure 20

- e. Make sure the tab on the harness bracket is still aligned with the notch in the support bracket (see Figures 18 and 21).

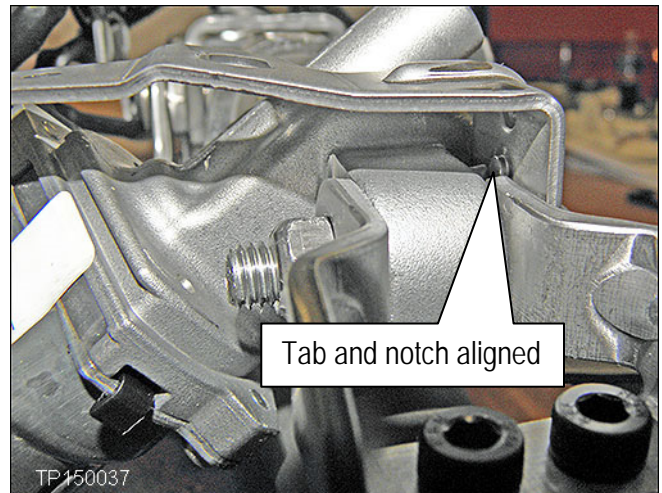

Figure 21

20. Apply UPR TUBE grease (white tube included with steering column kit) to the slide pads.



Figure 22

21. Make sure the slot in the tube is aligned with the stopper bolt hole as shown.

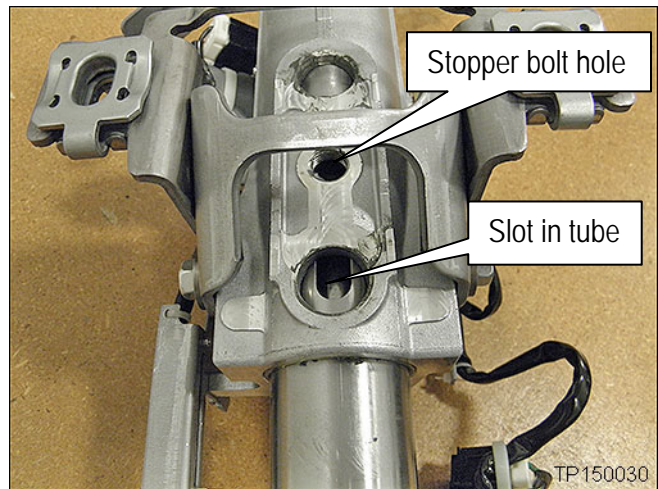

Figure 23

22. Re-install both slide pads.

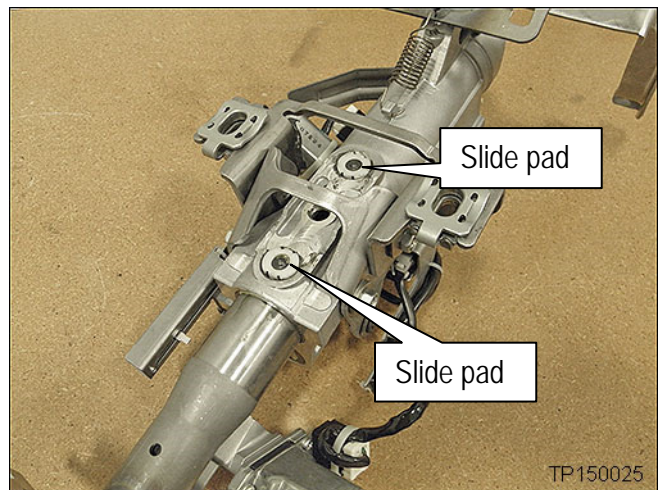

Figure 24

- Make sure the slide pads are positioned/aligned as shown.

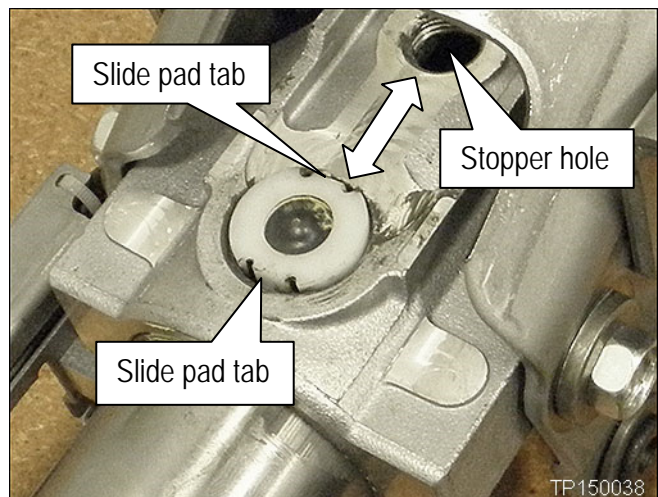

Figure 25

23. Re-install the slide pad retainer.

24. Re-install the telescope stopper bolt and torque to 13.5 N•m (1.4 kg-m, **10 ft-lb**).

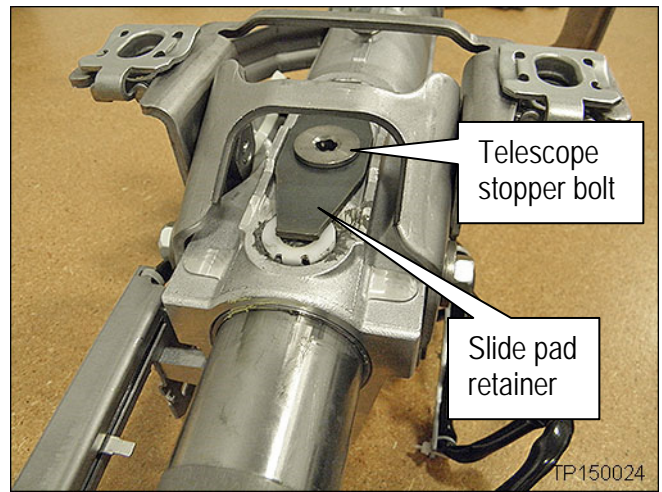

Figure 26

25. Tighten the hex nut on the end of the steering column.

- Use a wrench or other suitable tool to hold the steering lock gear while torquing the nut.
- Torque nut to:  
29.5 N•m (3.0 kg-m, **22 ft-lb**)

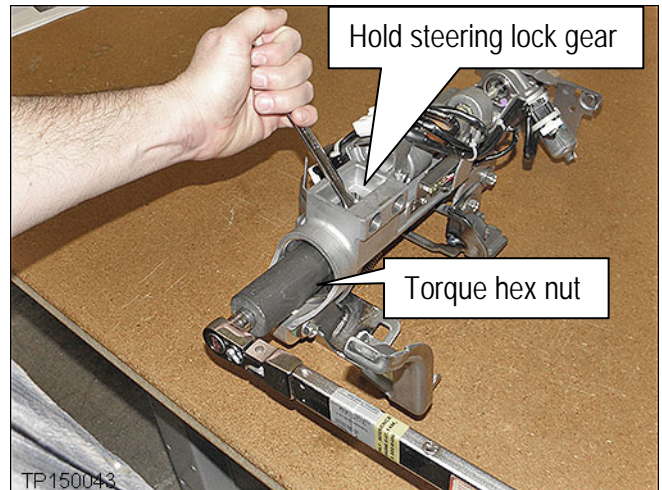

Figure 27

26. Re-install the upper joint.

- Reuse the upper joint that was removed.
- Make sure to match the alignment point (larger groove) on the joint with the alignment point (missing spline) on the shaft (see Figure 29).

27. Install and torque the lock bolt to:  
27 N•m (2.7 kg-m, 20 ft-lb)

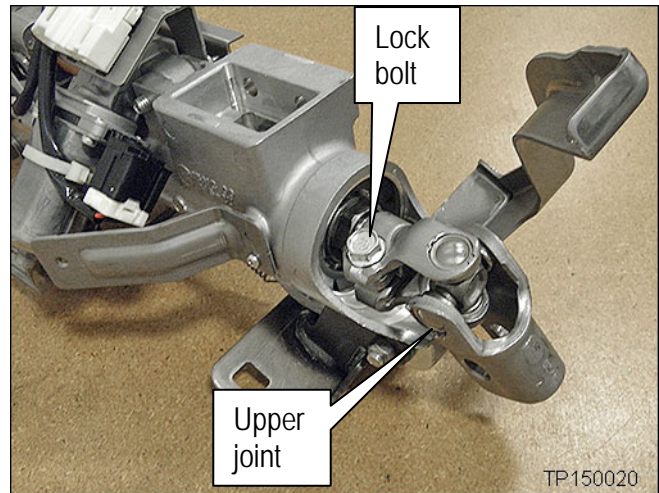

Figure 28

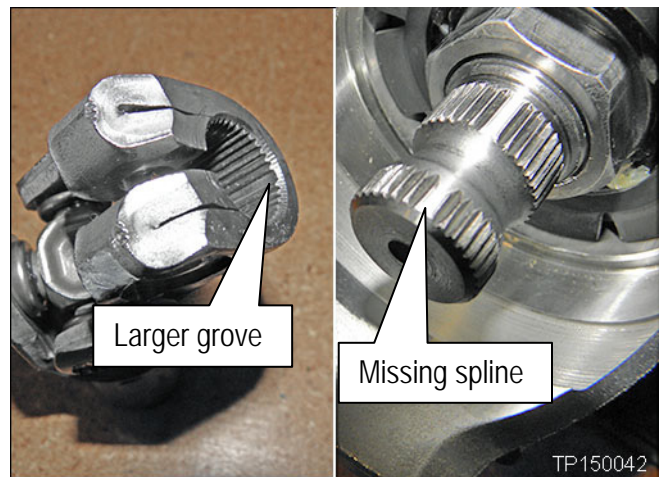

Figure 29

28. Replace the slide plate clips as follows:

**NOTE:** Only one clip is shown. Make sure to replace both slide plate clips.

a. Push the retainer as shown to release the slide plate clip.

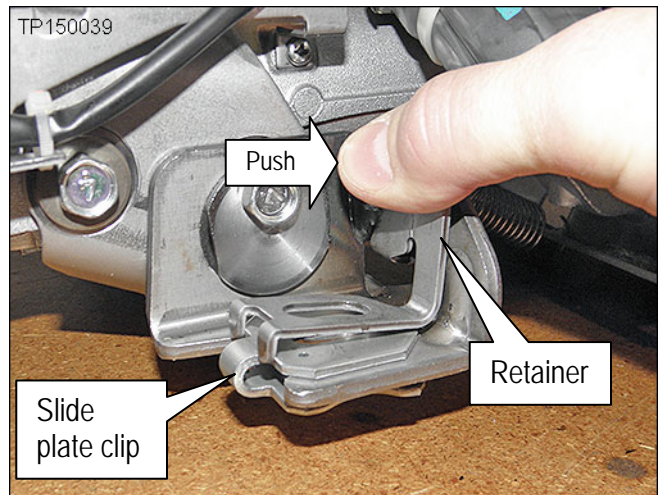

Figure 30

b. Remove the old slide plate clip and install the new one.

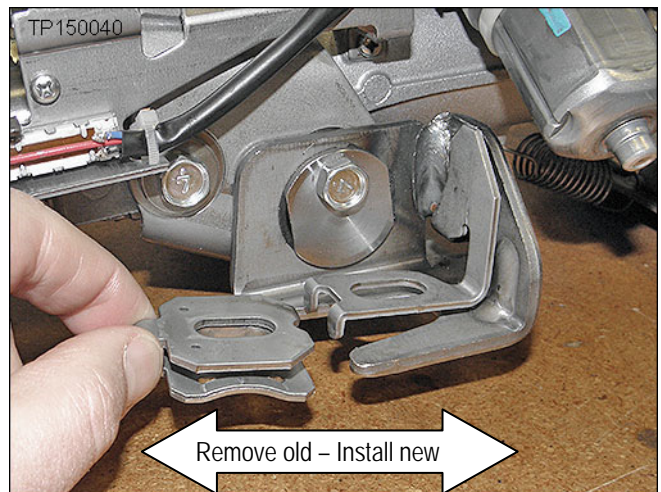

Figure 31

c. Use a medium flat blade screwdriver to push the retainer back into place.

d. Repeat a, b, and c above for the other slide plate clip.

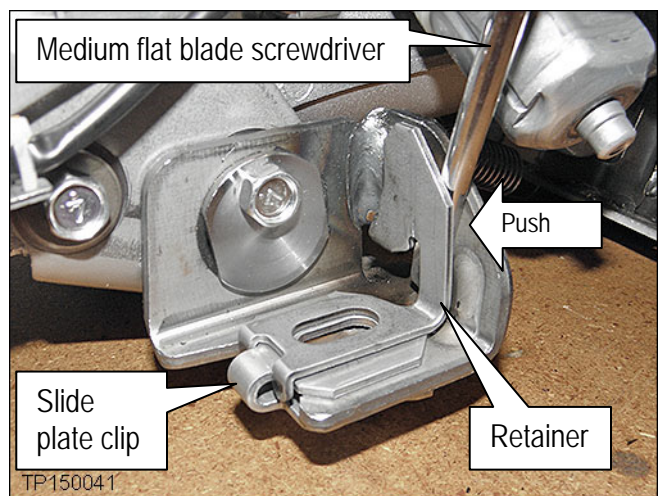

Figure 32

29. Re-install the steering column assembly into the vehicle.

- Refer to the Electronic Service Manual (ESM), section ST-Steering System, for steering column installation information. Make sure to reference Steering Column With Electric Motor.
- Make sure to use the new bolts and nuts included with the steering column kit.
- After installation of the new steering column, "ADJUSTMENT OF STEERING ANGLE SENSOR NEUTRAL POSITION" is required, as described in the ESM.

NOTE: If the Shaft and Tube assembly are separated, gently reassemble them.

- A single indexed spline is present on the shaft and corresponding tube, and can be difficult to see (Figure 33).
- The indexed spline will be on the same side as the engraved shaft number (on shaft) and the stamped mark on the end of the tube.
- Rotate the shaft one spline at a time until the shaft can be re-inserted into the tube with gentle force.

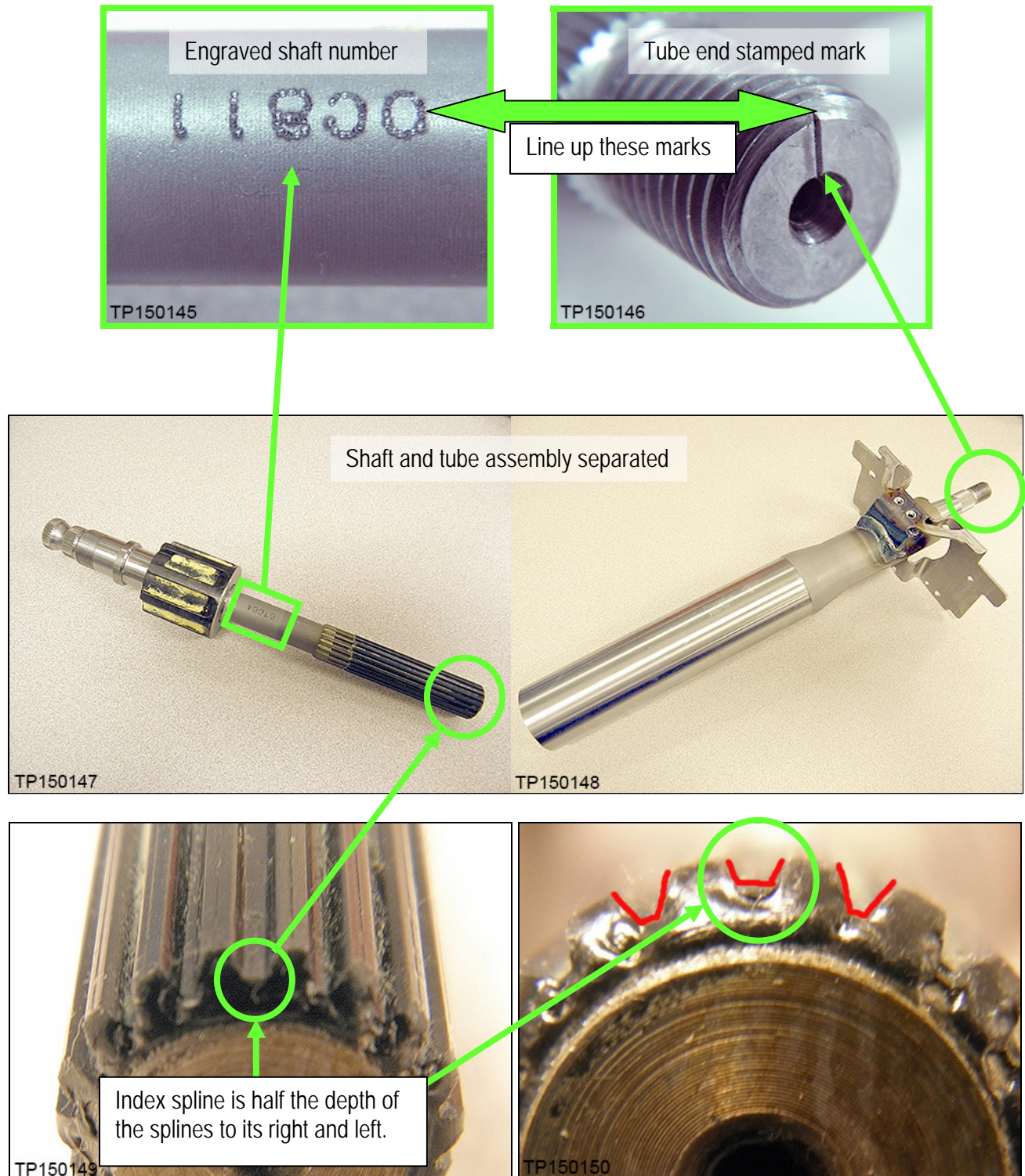

Figure 33

**PARTS INFORMATION**

DESCRIPTION	MODEL	PART #	QUANTITY
Steering Column Kit	FX35/FX50	D8812-1CA1D	1
	EX35	D8812-1BA1D	1
<b>Kit Includes</b>			
SHAFT&TUBE ASSY-STRG,UPR			1
PLATE-SLIDE, STRG BRKT (Slide Plate Clips)			2
BOLT-HEX,SPL WITH WASH			1
GREASE TUBE ASSY (KEY LOCK - yellow tube)			1
GREASE TUBE ASSY (UPR TUBE - white tube)			1
BOLT KEY LOCK UNIT			2
NUT STEERING WHEEL			1
NUT STEERING LWR JOINT			1
BOLT AIR BAG MODULE			2

**CLAIMS INFORMATION**

Submit a Campaign (CM) line claim using the following claims coding:

EX35

CAMPAIGN (CM) ID #	DESCRIPTION	OP CODE	FRT
R1501	Replace Steering Column Shaft	R15010	1.4 hrs.

FX35/50

CAMPAIGN (CM) ID #	DESCRIPTION	OP CODE	FRT
R1501	Replace Steering Column Shaft	R15011	1.5 hrs.



## OWNERS LETTER (TYPICAL OWNERS LETTER)

Dear Infiniti EX35 Owner:

This notice is sent to you in accordance with the National Traffic and Motor Vehicle Safety Act. Nissan has decided that a defect which relates to motor vehicle safety exists in certain 2008 model year Infiniti EX35 vehicles. Our records indicate that you own or lease the Nissan vehicle identified by the VIN inside of this notice.

### Reason for Recall

Certain 2008 model year Infiniti EX35 vehicles including yours may have been manufactured with an out of specification steering column assembly component. This issue may lead to excessive play in the steering wheel. If this occurs, you may notice extra looseness in the steering. If this condition is ignored and, if an excessive load is applied to pull the steering wheel towards the driver, this could lead to loss of steering control and increase the risk of a crash.

### What Infiniti Will Do

Your Infiniti retailer will replace the steering shaft on your vehicle. This service is free of charge for parts and labor. It should take less than 2 hours to complete, but your Infiniti retailer may require your vehicle for a longer period of time based upon their work schedule.

### What You Should Do

Contact your Infiniti retailer at your earliest convenience in order to arrange an appointment to have your vehicle repaired. **If you hear grinding noises coming from the steering column area, or notice extra looseness in the steering, or unusual upward or downward movement of the steering assembly, please STOP DRIVING and call the Infiniti Consumer Affairs Department at 1-800-662-6200 immediately to arrange for towing service.**

Please bring this notice with you when you keep your service appointment. Instructions have been sent to your Infiniti retailer.

If you have additional questions you may contact Infiniti Consumer Affairs Department, P.O. Box 685003, Franklin, TN 37068-5003. The toll free number is 1-800-662-6200. You may also submit a complaint to the Administrator, National Highway Traffic Safety Administration, 1200 New Jersey Avenue, SE., Washington, DC 20590; or call the toll-free Vehicle Safety Hotline at 1-888-327-4236 (TTY: 1-800-424-9153); or go to <http://www.safercar.gov>.

Federal law requires that any vehicle lessor receiving this recall notice must forward a copy of this notice to the lessee within ten days.

Thank you for your cooperation. We are indeed sorry for any inconvenience this may cause you.

