

April 14, 2015

01752 Version 1

## SRS Unit Collection

### AFFECTED VEHICLES

Year	Model	Trim	VIN Range
2003	Odyssey	ALL	Check the iN VIN status for eligibility

### BACKGROUND

American Honda is conducting a study of SRS units from selected vehicles. Check the iN VIN status for applicable vehicles. If you find an applicable vehicle with the SRS indicator on, do not use this bulletin to collect the SRS unit. This procedure will not repair the vehicle.

To help American Honda collect the SRS units for the study, **please submit claims as quickly as possible** so that these units can be called in for inspection.

After this study is complete, this bulletin will be discontinued.

### CORRECTIVE ACTION

Inspect the vehicle to determine if you need to follow REPAIR PROCEDURE A or REPAIR PROCEDURE B to remove the SRS unit.

### PARTS INFORMATION

Part Name	Part Number	Quantity
SRS Unit Kit (contains SRS unit ([1], Torx bolts [4], nylon tie [1], foam piece [1], clip [1])	06772-S0X-306	1

#### NOTE:

- Return the removed SRS unit in the box the new one came in.
- If the SRS unit is not returned, the warranty claim for that vehicle will be charged back to your dealership.

### TOOL INFORMATION

Tool Name	Tool Number	Quantity
SCS Service Connector	07PAZ-0010100	1

**CUSTOMER INFORMATION:** The information in this bulletin is intended for use only by skilled technicians who have the proper tools, equipment, and training to correctly and safely maintain your vehicle. These procedures should not be attempted by "do-it-yourselfers," and you should not assume this bulletin applies to your vehicle, or that your vehicle has the condition described. To determine whether this information applies, contact an authorized Honda automobile dealer.

## WARRANTY CLAIM INFORMATION

Please file a claim for this collection **within 48 hours of the repair** so that these SRS units can be called in for inspection.

Operation Number	Description	Flat Rate Time	Defect Code	Symptom Code	Template ID	Failed Part Number
7511B4	Repair Procedure A - Inspect the vehicle, replace the SRS unit, and remove the noise suppressor. (includes resetting power window, idle learn, and OPDS initialization)	1.2 hrs	5YT00	JP500	15-026A	77960-S0X-L81
7511B3	Repair Procedure B - Inspect the vehicle and replace the SRS unit. (includes resetting power window, idle learn, and OPDS initialization)	0.8 hr	5YT00	JP500	15-026B	77960-S0X-L81

Skill Level: Repair Technician

## INSPECTION PROCEDURE

1. Turn the ignition switch to the ON (II) position and check if the SRS indicator comes on for about 6 seconds, then turns off.
  - If the indicator comes on, then turns off after about 6 seconds, go to step 2.
  - If the indicator does not come on, or if it stays on, this bulletin does not apply. Any repairs to the SRS system are the customer's responsibility.
2. Make sure you have the anti-theft codes for the audio and navigation system (if applicable) and write down the frequencies for the radio presets.
3. Disconnect the negative battery cable and wait at least 3 minutes before beginning work.
4. Remove the driver's and front passenger's lower heater covers.

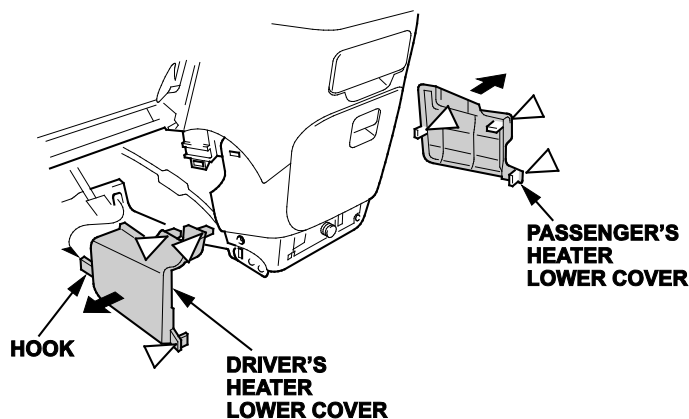

5. Check if there is an updated subharness with a noise suppressor installed.
  - If the vehicle has an updated subharness and noise suppressor installed, go to REPAIR PROCEDURE A.
  - If the does not have an updated subharness and noise suppressor installed, go to REPAIR PROCEDURE B.

**UPDATED SRS SUB HARNESS WITH NOISE SUPPRESSOR**  
 Repair Procedure A

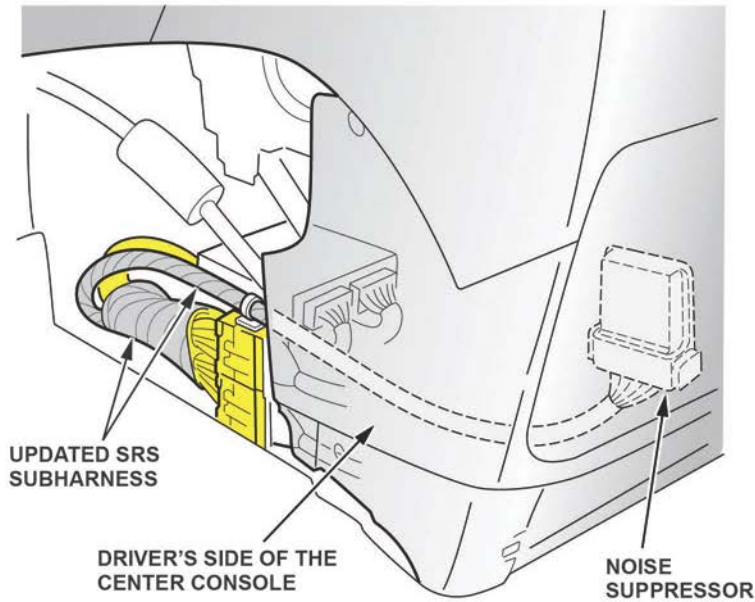

**OLD SRS SUB HARNESS**  
 Repair Procedure B

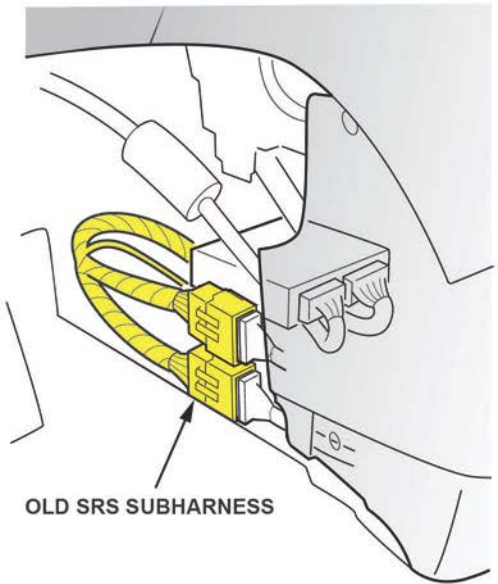

**REPAIR PROCEDURE A**

1. Remove the center lower trim.

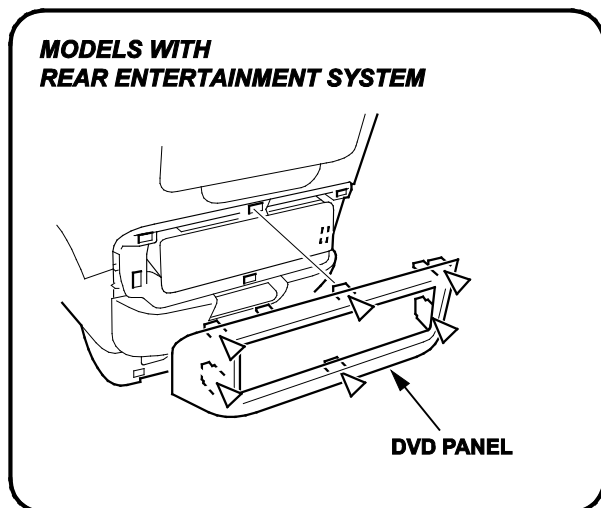
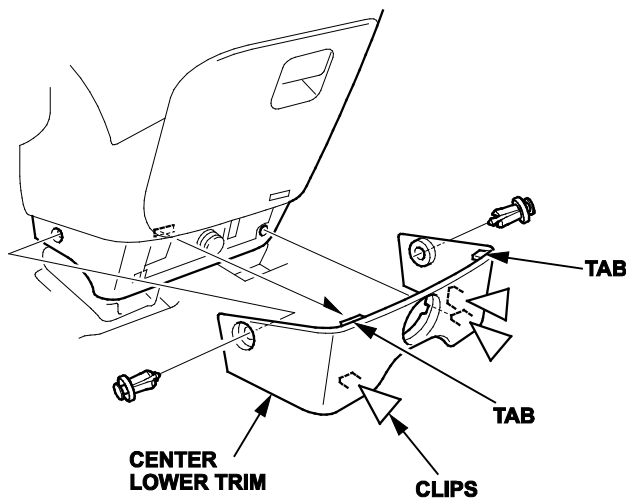

2. Remove the center lower pocket.

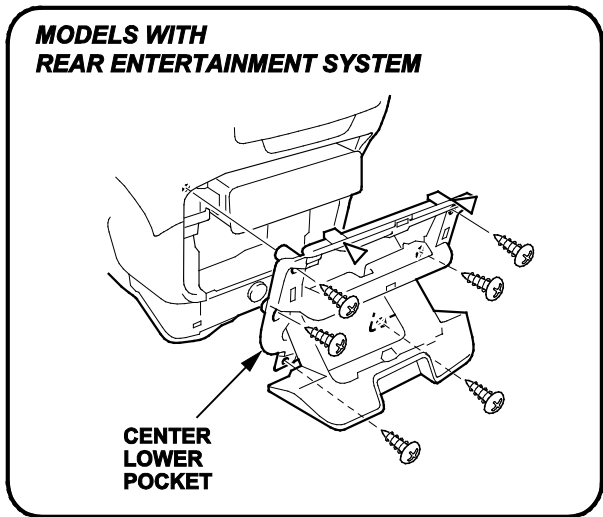
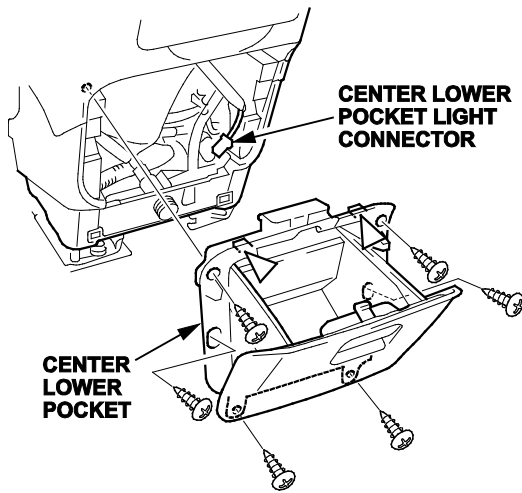

3. Remove the noise suppressor from the bracket and disconnect the connector. The suppressor will not be reused.

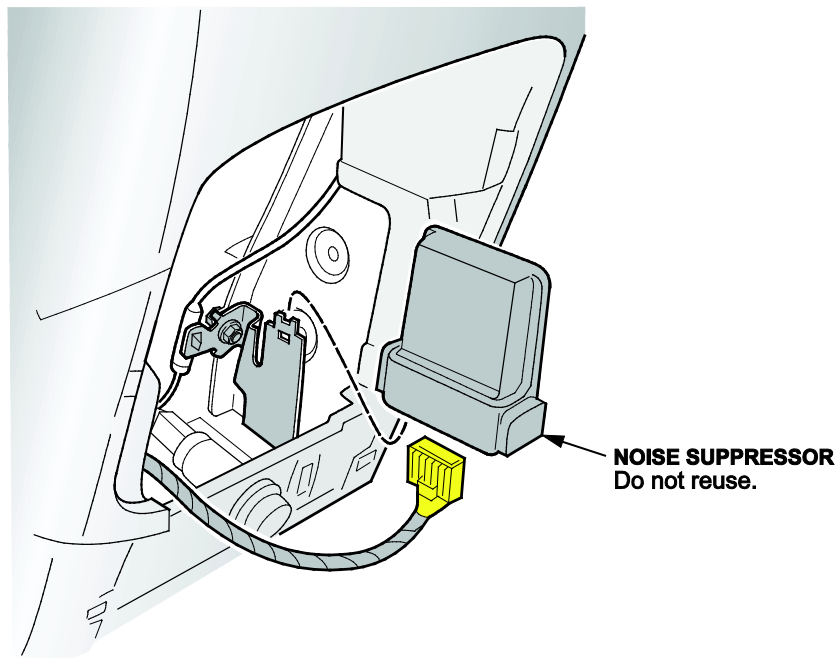

4. Disconnect the connector and the clip.

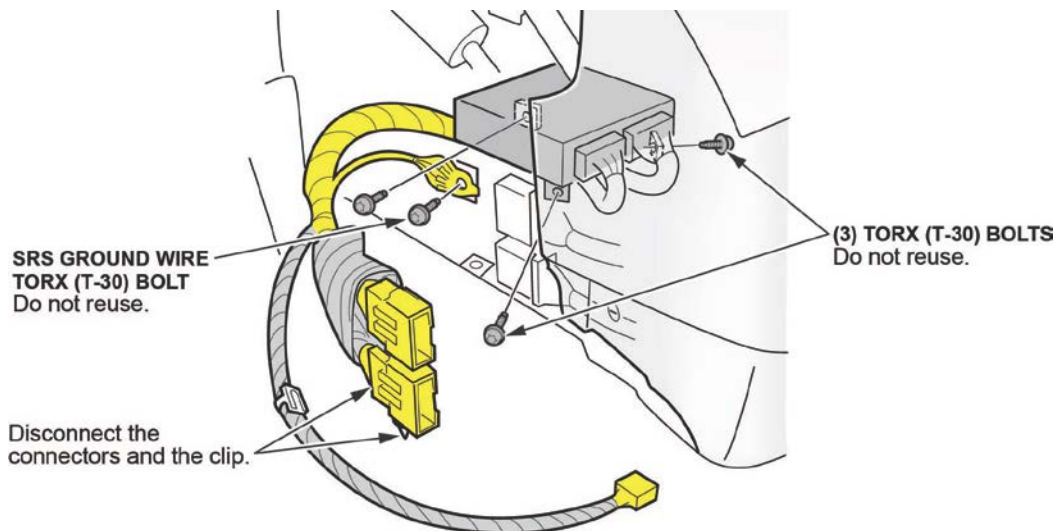

5. Remove the SRS unit by removing the three Torx bolts.
6. Remove the ground wire by removing the Torx bolt.
7. Remove the SRS unit and subharness from the vehicle.

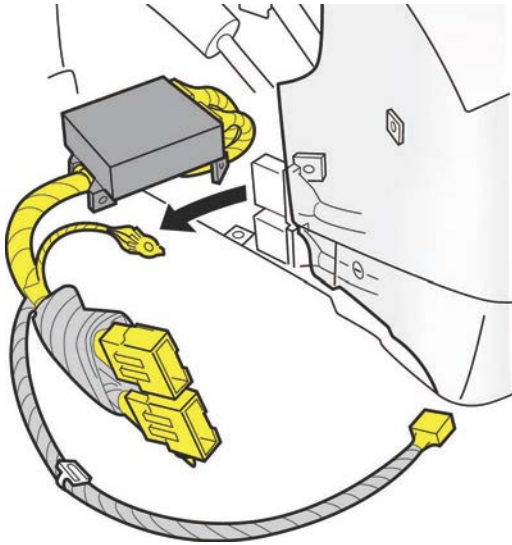

8. Remove the subharness clip from the underside of the SRS unit, then disconnect the connectors.

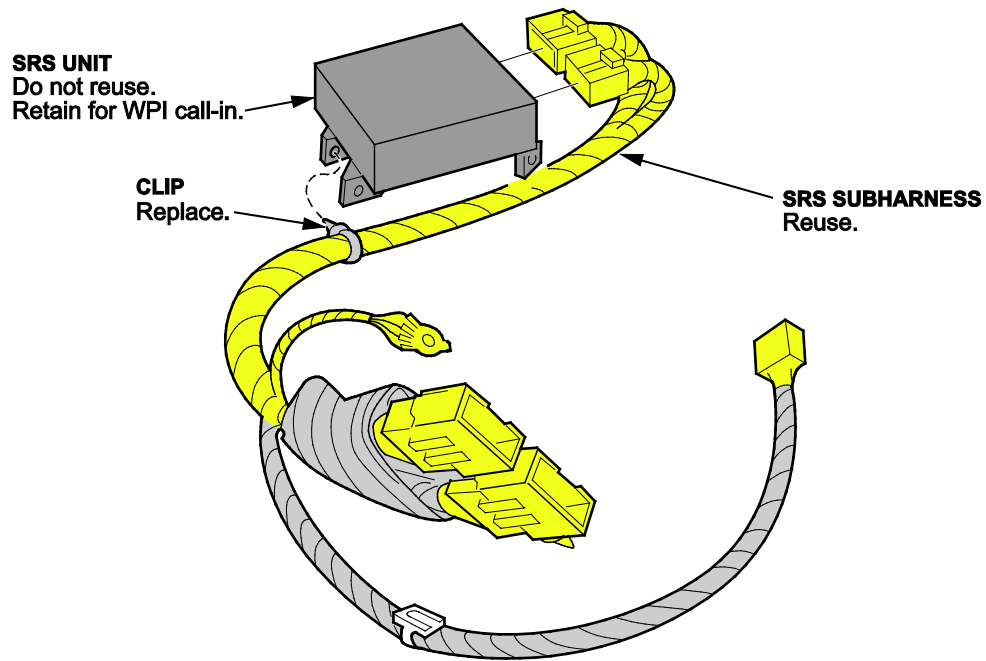

9. Replace the subharness clip.
10. Connect the subharness to the new SRS unit and connect the clip.

11. Apply a piece of 80 mm x 80 mm cushion tape over the noise suppressor connector as shown.

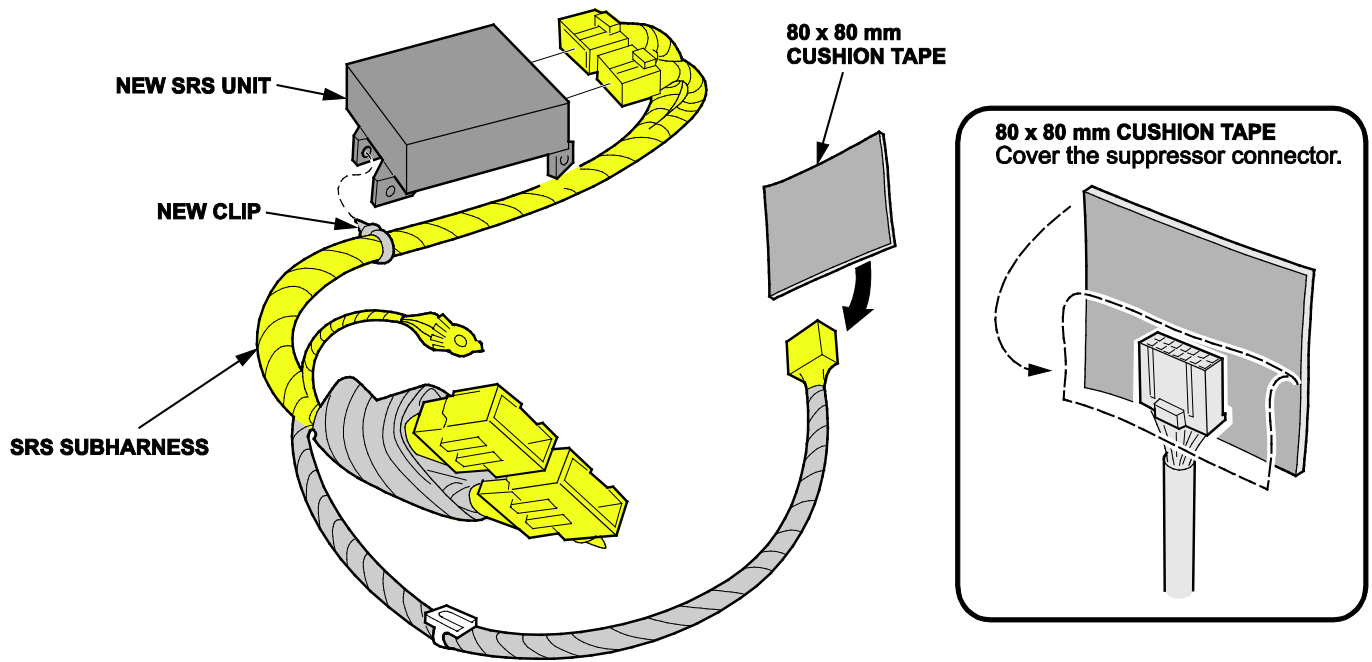

12. Reinstall the new SRS unit and existing SRS subharness into the vehicle with three new Torx bolts and torque them to **9.8 N·m (7.2 lb-ft)**.

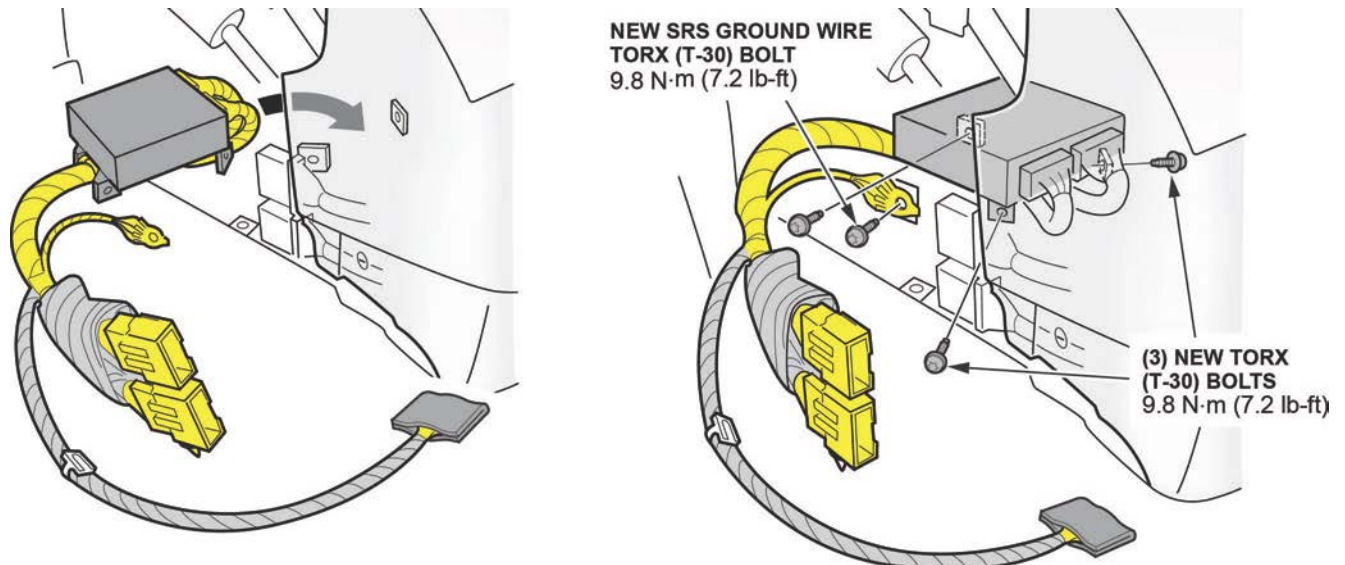

13. Reinstall the ground wire with a new Torx bolt and torque it to **9.8 N·m (7.2 lb-ft)**.

14. Reconnect the connectors and the clip.

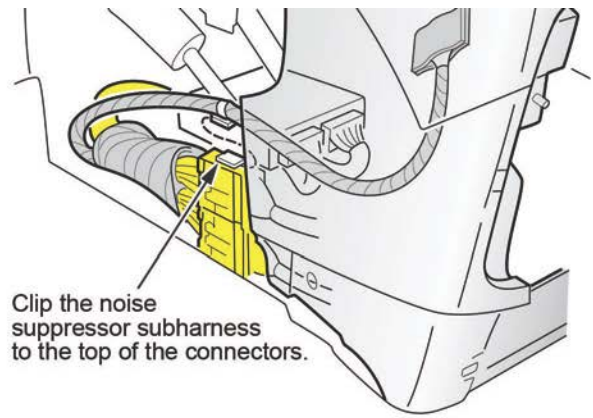
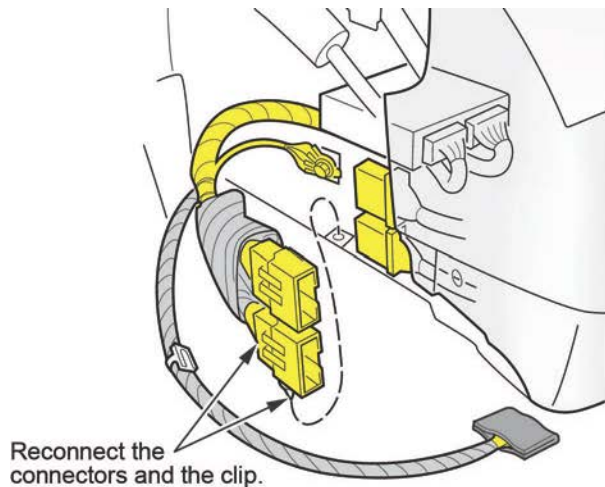

15. Clip the noise suppressor subharness to the top of the connectors.

16. Fold the subharness over and secure it with the nylon tie as shown.

NOTE: Make sure the noise suppressor subharness does not block the driver's heater lower cover connection point.

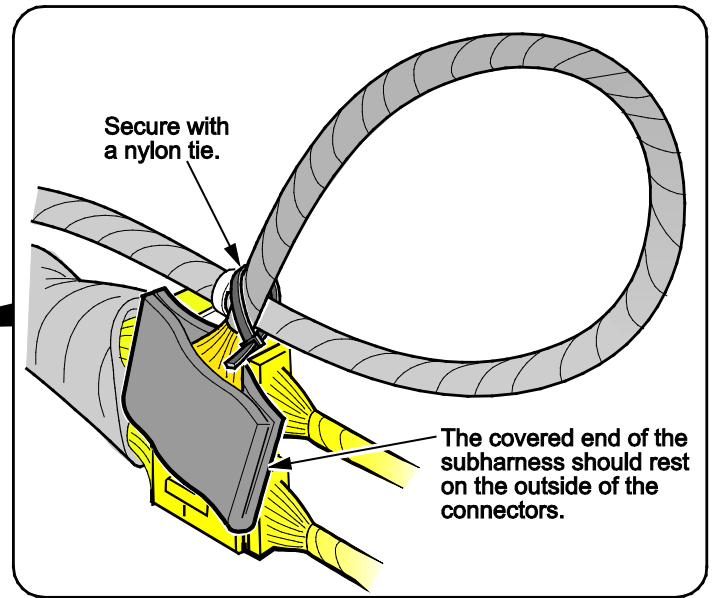
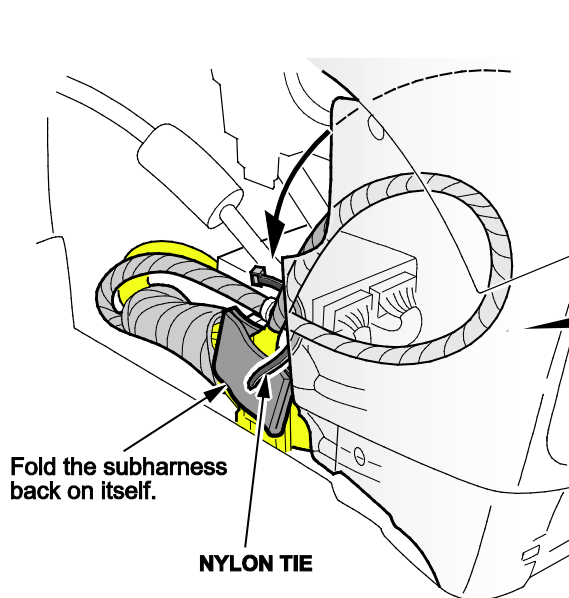

17. Reinstall the driver's and front passenger's lower heater covers, the center lower pocket, and the center console trim.

18. Reconnect the negative battery cable.

19. Enter the anti-theft codes for the audio and navigation system (if applicable), then enter the customer's radio presets.

20. Reset the power window control unit:

- Turn the ignition switch to LOCK (0), then back to ON (II).
- Press the driver's window switch firmly to the second detent to lower the window all the way down.
- When the window reaches the bottom, continue holding the driver's window switch in the down position for 2 seconds.
- Pull the driver's window switch up and hold it to the second detent to raise the window without stopping.
- When the window reaches the top, continue holding the driver's window switch in the up position for 2 seconds.

21. *Vehicles without navigation:* set the clock.

22. Do the idle learn procedure.

- Make sure all electrical items (A/C, audio unit, defogger, lights, etc.) are off.
- Start the engine and let it warm up to its normal operating temperature (the cooling fans cycle twice).
- Let the engine idle (throttle closed and all electrical items off) for 10 minutes.

23. Initialize the OPDS. Refer to INITIALIZING THE OPDS UNIT at the end of this bulletin.

24. Place the removed SRS unit into the SRS unit box. Complete the Warranty Parts Identification Tag and follow your dealership's process to return the package to WPI.

## REPAIR PROCEDURE B

NOTE: The foam piece and nylon tie in the kit are not needed for this repair procedure.

1. Disconnect the two yellow connectors and remove the clip from the floor.

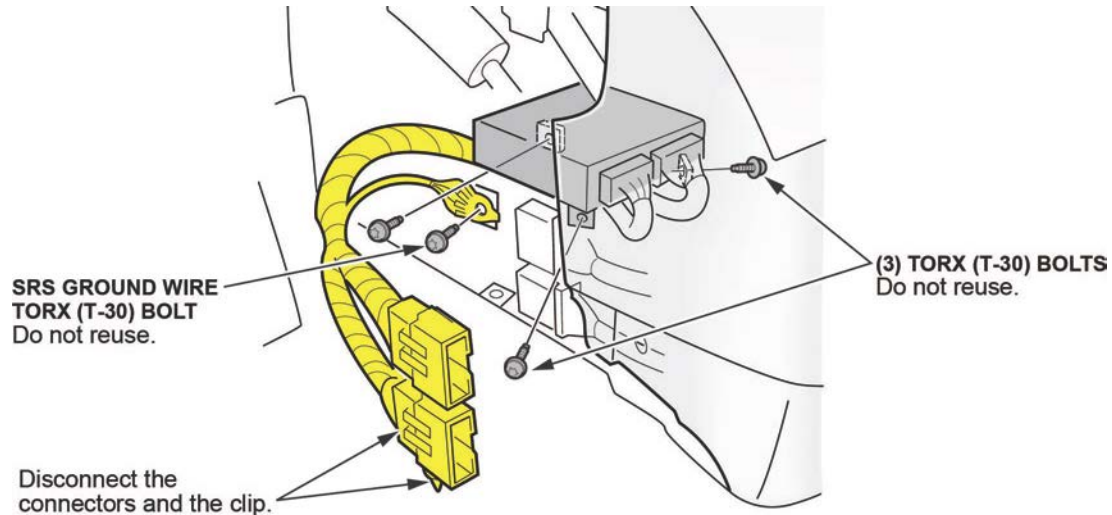

2. Remove the SRS unit by removing the three Torx bolts.

3. Remove the ground wire by removing the Torx bolt.

4. Remove the SRS unit and subharness from the vehicle.

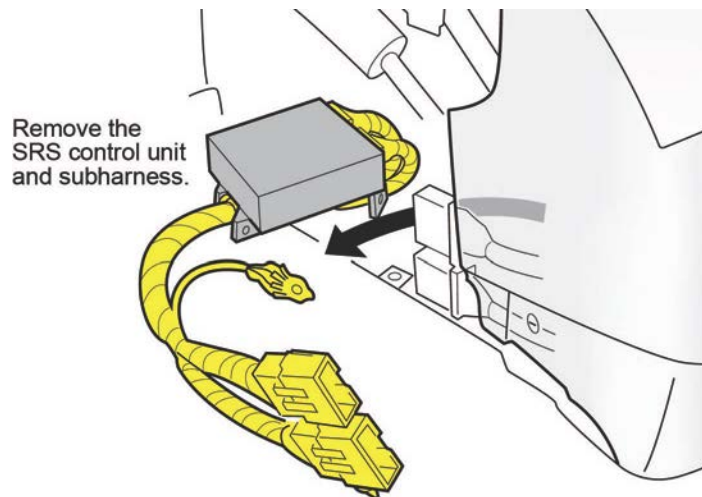



5. Remove the subharness clip from the underside of the SRS unit, then disconnect the subharness from the unit.

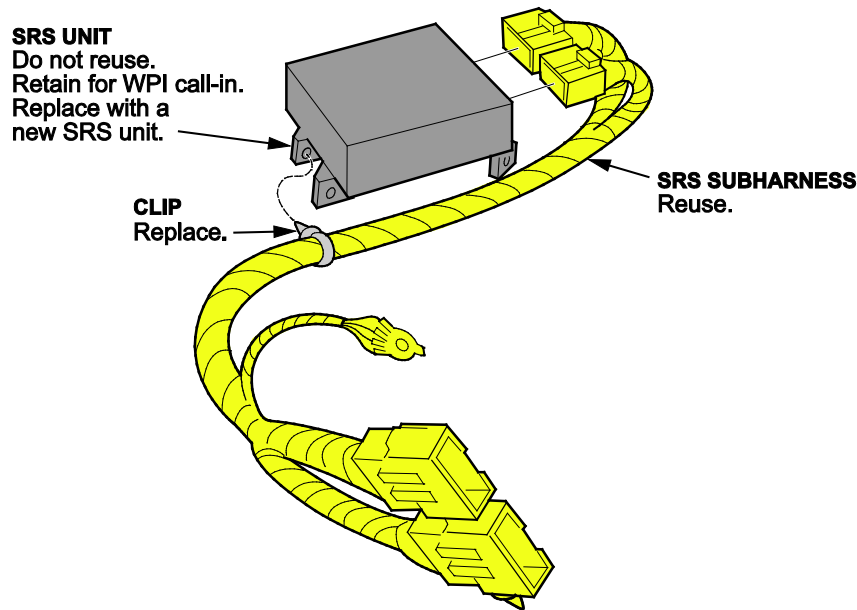

6. Install a new subharness clip onto the original subharness, then connect the subharness to the new SRS unit.
7. Reinstall the new SRS unit and existing SRS subharness into the vehicle with three new Torx bolts and torque them to **9.8 N·m (7.2 lb-ft)**.

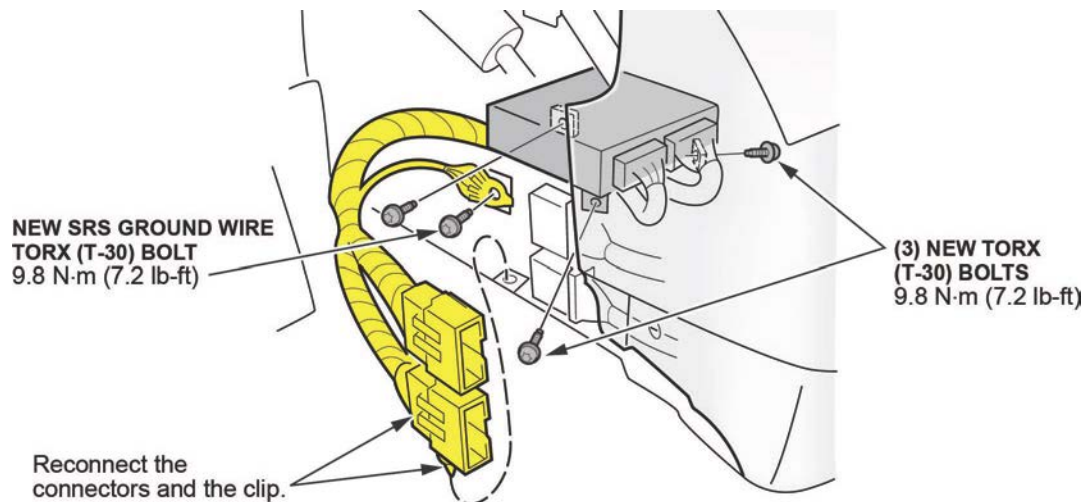

8. Reinstall the ground wire with a new Torx bolt and torque it to **9.8 N·m (7.2 lb-ft)**.
9. Reconnect the connectors and the clip.
10. Reinstall the driver's and front passenger's lower heater covers.
11. Reconnect the negative battery cable.
12. Enter the anti-theft codes for the audio and navigation system (if applicable), then enter the customer's radio presets.
13. Reset the power window control unit:
- Turn the ignition switch to LOCK (0), then back to ON (II).
  - Press the driver's window switch firmly to the second detent to lower the window all the way down.
  - When the window reaches the bottom, continue holding the driver's window switch in the down position for 2 seconds.
  - Pull the driver's window switch up and hold it to the second detent to raise the window without stopping.
  - When the window reaches the top, continue holding the driver's window switch in the up position for 2 seconds.

14. *Vehicles without navigation:* set the clock.
15. Do the idle learn procedure.
  - Make sure all electrical items (A/C, audio unit, defogger, lights, etc.) are off.
  - Start the engine, and let it warm up to its normal operating temperature (the cooling fans cycle twice).
  - Let the engine idle (throttle closed and all electrical items off) for 10 minutes.
16. Initialize the OPDS. Refer to INITIALIZING THE OPDS UNIT at the end of this bulletin.
17. Place the removed SRS unit into the SRS unit box. Complete the Warranty Parts Identification Tag and follow your dealership's process to return the package to WPI.

## INITIALIZING THE OPDS UNIT

There are two ways you can initialize the OPDS: both require using the HDS, the preferred method and the manual mode.

### Preferred Method

1. Adjust the front passenger's seat-back to a normal upright position and remove anything that is on or near the seat.
2. Turn the ignition switch to LOCK (0).
3. Connect the HDS with the latest software version to the DLC.
4. Turn the ignition switch to ON (II), then turn on the HDS.
5. On the HDS, select **System Selection Menu**, then select **SRS**.
6. Select **Mode Menu**, then select **Miscellaneous Test**.
7. Select **OPDS Initialization**.
8. Follow the onscreen prompts to complete the OPDS initialization. If the initialization fails, try initializing the OPDS unit using the Manual Mode.

### Manual Mode

1. Adjust the front passenger's seat-back to a normal upright position and remove anything that is on or near the seat.
2. Turn the ignition switch to LOCK (0).
3. Connect the HDS with the latest software version to the DLC.
4. Leave the ignition switch in LOCK (0) and turn on the HDS.
5. On the HDS, from the **Select Screen Mode** screen, select **SCS** and follow the screen prompts.
6. Plug in the SCS service connector (T/N 07PAZ-0010100) into the MES (memory erase signal) connector as shown. **Do not use a jumper wire.**

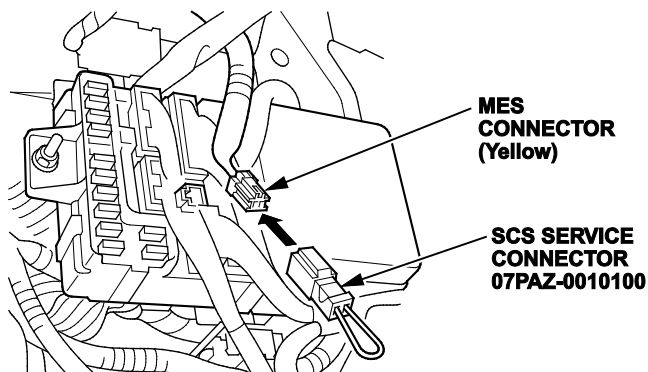

7. Turn the ignition switch to ON (II).
8. Watch the SRS indicator. It will come on for about 6 seconds, then turn off. Unplug the SCS service connector from the MES connector within 4 seconds of the indicator turning off.
9. Wait for the SRS indicator to turn back on and plug in the SCS service connector into the MES connector within 4 seconds.

10. When the SRS indicator goes off a second time, unplug the SCS service connector.
11. Watch the SRS indicator.
  - If the indicator blinks twice and then goes off, the OPDS unit is initialized. Turn the ignition switch to LOCK (0) and disconnect the HDS. The initialization is done; return the vehicle to the customer.
  - If the indicator blinks twice and then stays on, the OPDS unit is initialized, but there are SRS DTCs that need to be cleared. Go to step 13.
  - If the indicator stays on without first blinking, the OPDS unit is not initialized. The front passenger seat may not be completely dry. Start the engine and turn on the A/C. Close the doors and windows and run the A/C in Recirculation mode for 30 minutes. (This will dry out any moisture that may be in the front passenger's seat.) Then, repeat steps 3 thru 11.
12. Turn the ignition switch to LOCK (0) and disconnect the HDS.
13. Plug the SCS service connector into the MES connector. **Do not use a jumper wire.**
14. Turn the ignition switch to ON (II).
15. Watch the SRS indicator. It comes on for about 6 seconds and then goes off. Unplug the SCS service connector from the MES connector within 4 seconds of the indicator turning off.
16. Wait for the SRS indicator to come on again and plug the SCS service connector into the MES connector within 4 seconds of the indicator coming on.
17. Wait for the SRS indicator to go off and unplug the SCS service connector from the MES connector within 4 seconds. The SRS indicator blinks twice to indicate that the memory has been cleared.
18. Turn the ignition switch to LOCK (0) and wait for 10 seconds.
19. Turn the ignition switch to ON (II). The SRS indicator comes on for 6 seconds and then goes off.
  - If the SRS indicator comes on and turns off after about 6 seconds, the memory is clear and the vehicle is OK.
  - If the SRS indicator does not turn off, the clearing failed. Repeat steps 12 through 19 two more times.

NOTE: If the DTC clearing fails again, check for set SRS DTCs and troubleshoot in accordance with the electronic service manual.

END