

October 31, 2015

01466 Version 3

Safety Recall: SRS Unit

Supersedes S/B 15-011, dated October 9, 2015, to revise the information highlighted in **yellow**

AFFECTED VEHICLES

Year	Model	VIN Range
2003	MDX	Check the iN VIN status for eligibility

REVISION SUMMARY

- The INSPECTION PROCEDURE was changed.
- The REPAIR PROCEDURE was changed.

BACKGROUND

Electrical noise (interference) generated by the vehicle may inadvertently cause some or all of the vehicle's airbags to deploy. Many vehicles had an electrical noise suppressor installed under S/B 13-038, *Safety Recall: Electrical Noise May Cause Inadvertent Front Airbag Deployment*. In rare cases, even with the noise suppressor installed, some front airbags inadvertently deployed.

NOTE: If the VIN status inquiry indicates that the vehicle is subject to any open safety recalls, including an airbag inflator campaign/recall, make sure to also complete those recall repairs before returning the vehicle to the client. If you are unable to complete any open recall, advise the client of the recall status and when the recall may be completed.

CLIENT NOTIFICATION

Owners of affected vehicles will be sent a notification of this campaign.

Do an iN VIN status inquiry to make sure the vehicle is shown as eligible.

Some vehicles affected by this campaign may be in your new or used vehicle inventory. These vehicles must be repaired before they are sold.

Should your dealership sell an unrepaired vehicle that subsequently causes injury or damage because of the recalled item, the dealership will be solely responsible to the damaged party, and will be required to defend and indemnify American Honda for any resulting claims. To see if a vehicle in inventory is affected by this recall, do a VIN status inquiry before selling it.

CORRECTIVE ACTION

Inspect the vehicle and based on your results, do one of the following:

- Do nothing, the vehicle is up to date.
- Replace the SRS unit.
- Remove the noise suppressor and replace the SRS unit.

NOTE: When you install a new SRS unit, do not initialize the OPDS unit.

PARTS INFORMATION

Part Name	Part Number	Quantity
SRS Unit Kit (contains SRS Unit [1], Torx bolts [4], wire tie [1], foam piece [1], clip [1])	06772-S3V-306	1

Page 1 of 15

CLIENT INFORMATION: The information in this bulletin is intended for use only by skilled technicians who have the proper tools, equipment, and training to correctly and safely maintain your vehicle. These procedures should not be attempted by "do-it-yourselfers," and you should not assume this bulletin applies to your vehicle, or that your vehicle has the condition described. To determine whether this information applies, contact an authorized Acura automobile dealer.

WARRANTY CLAIM INFORMATION

NOTE: Do not use this warranty information for vehicles where the SRS unit is being replaced because of a collision.

Operation Number	Description	Flat Rate Time	Defect Code	Symptom Code	Template ID	Failed Part Number
7515A1	Inspect the SRS unit – the vehicle is OK.	0.3 hr	5YT00	JN700	15-011N	77960-S3V-A81
7511B9	Repair Procedure A - Inspect the vehicle, replace the SRS unit, and remove the noise suppressor. (includes resetting power window and idle learn)	1.0 hr	5YT00	JN700	15-011P	77960-S3V-A81
7511C0	Repair Procedure B - Inspect the vehicle and replace the SRS unit. (includes resetting power window and idle learn)	0.6 hr	5YT00	JN700	15-011Q	77960-S3V-A81

INSPECTION PROCEDURE

- Turn the ignition to ON and check if the SRS indicator comes on for about 6 seconds, then goes out.
 - If the indicator comes on, then goes out after about 6 seconds, go to step 2.
 - If the indicator does not come on, or if it stays on, connect the HDS and write the DTCs on the RO.
 - Contact the client and inform them that there is a problem with the SRS system and explain that replacing the SRS unit may not fix the problems causing the indicator light to illuminate as the SRS unit replacement was only intended address the specific problem that led to the recall.
 - If the client declines the client pay repairs, make sure you write down the description of the problem and any DTCs on the RO. Also, state that the SRS system is not operating properly and may pose a risk to the front occupants in the event of a collision; either because the airbags did not deploy, or the airbags deploy in a manner that does not account for all factors involved in the collision.
 - After the SRS unit is replaced, additional client pay repairs will likely be needed to return the SRS system to proper operation.**
- Turn the ignition to OFF and wait for 30 seconds. Turn the ignition to ON and check if the SIDE AIRBAG OFF indicator comes on for about 6 seconds, then goes out.

NOTE: Do not confuse the SIDE AIRBAG OFF indicator and the PASSENGER AIRBAG OFF indicator.

- If the indicator comes on, then goes out after about 6 seconds, go to step 3.
- If the indicator does not come on at all, or comes on and stays on, connect the HDS and write the DTCs on the RO.
 - Have the service consultant contact the client and inform them that there is a problem with the side airbag and explain that replacing the SRS unit may not fix the problems, causing the indicator to illuminate. The SRS unit replacement was only intended to address the specific problem that led to the recall.
 - If the client declines the client pay repairs, make sure you write down the description of the problem and any DTCs on the RO. Also, state that the SRS system is not operating properly and may pose a risk to the front occupants in the event of a collision; either because the airbags may not deploy, or the airbags may deploy in a manner that does not account for all factors involved in the collision.
 - After the SRS unit is replaced, additional client pay repairs will likely be needed to return the SRS system to proper operation.**

3. Make sure the OPDS is working properly by leaving the ignition turned to ON, then grabbing and holding the passenger seat back outside bolster with both hands for about 30 seconds. The SIDE AIRBAG OFF indicator should come on.
 - If the SIDE AIRBAG OFF indicator comes on, go to step 4.
 - If the indicator does not come on, connect the HDS and write any SRS DTCs on the RO.
 - Have the service advisor contact the client and inform them that there is a problem with the OPDS and explain that replacing the SRS unit may not fix the problems. The SRS unit replacement was only intended to address the specific problem that led to the recall.
 - If the client declines the client pay repairs, make sure you write down the description of the problem and any DTCs on the RO. Also, state that the SRS system is not operating properly and may pose a risk to the front occupants in the event of a collision; either because the airbags may not deploy, or the airbags may deploy in a manner that does not account for all factors involved in the collision.
 - **After the SRS unit is replaced, additional client pay repairs will likely be needed to return the SRS system to proper operation.**
4. Make sure you have the anti-theft codes for the audio and navigation system (if applicable) and write down the frequencies for the audio unit presets.
5. Disconnect the negative battery cable and wait at least 3 minutes before beginning work.
6. Detach the clips and release the hooks, then remove the driver's and front passenger's console side trim.

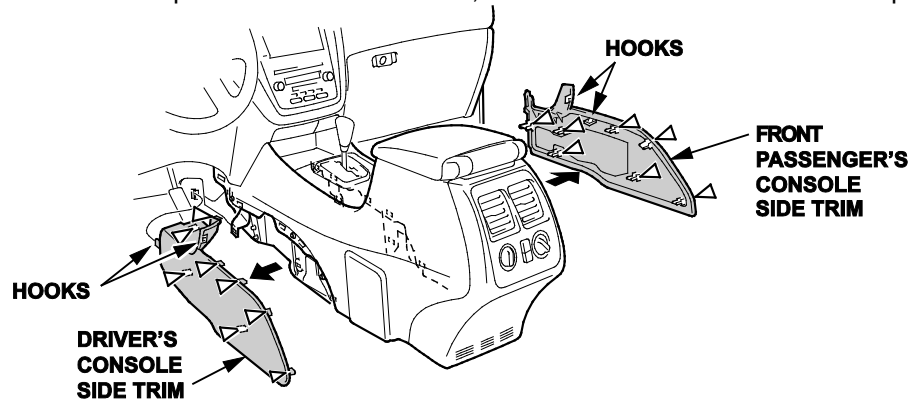

7. Inspect the subharness and note its arrangement:

- The original subharness is installed in the vehicle.
- There is an updated subharness connected to the noise suppressor.
- There is an updated subharness that has been taped up as shown and the noise suppressor has been removed.

UPDATED SRS SUBHARNESS WITH NOISE SUPPRESSOR

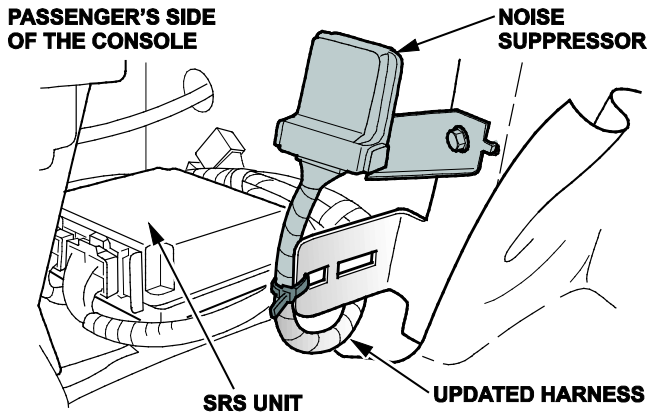

ORIGINAL SRS SUBHARNESS

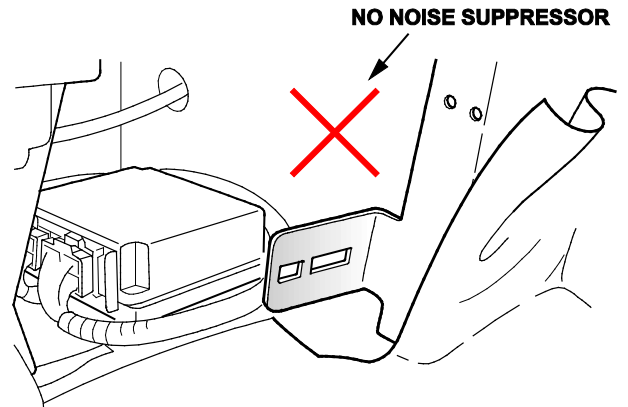

UPDATED SRS SUBHARNESS WITH NO NOISE SUPPRESSOR

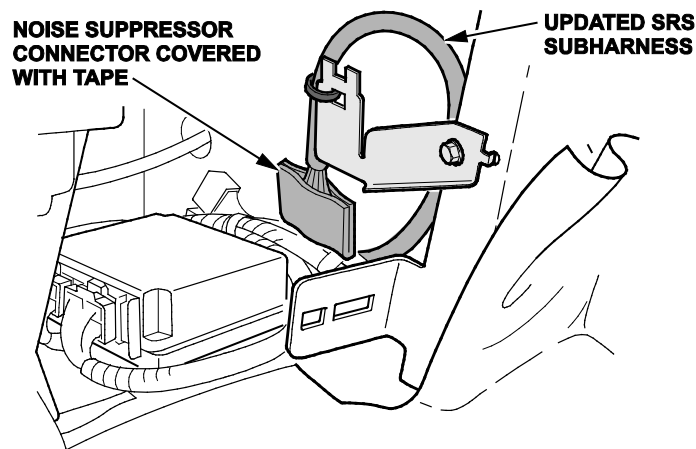

- Write down the SRS unit P/N on the RO.

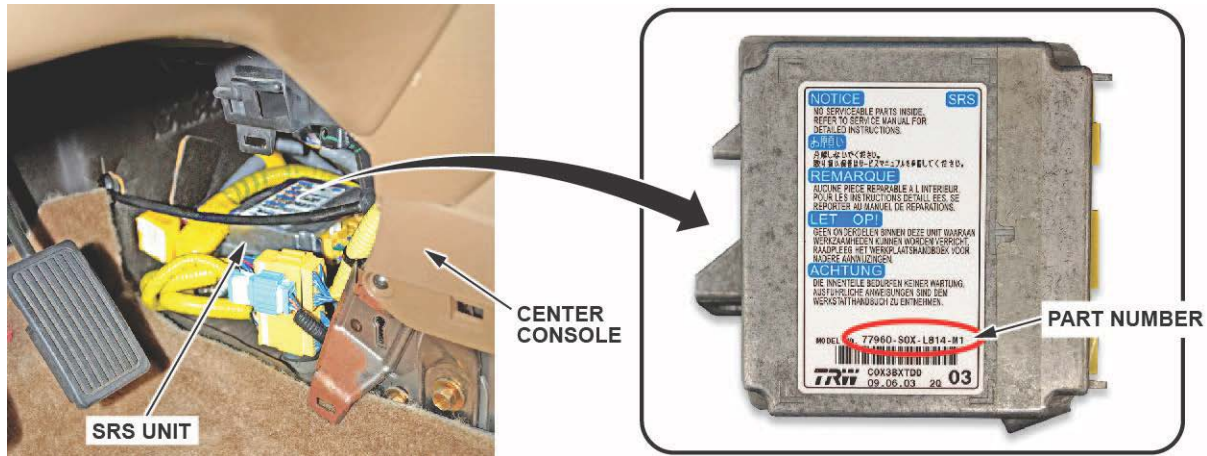

- Check the SRS unit P/N and arrangement of the subharness against the table below and follow the correct repair action.

NOTE: When you install a new SRS unit, do not initialize the OPDS unit.

SRS Unit P/N	Subharness Arrangement	Repair Action
77960-S3V-A81X-XX	Original subharness is installed.	REPAIR PROCEDURE B
77960-S3V-A81X-XX	Updated subharness with a noise suppressor installed.	REPAIR PROCEDURE A
77960-S3V-307X	Original subharness is installed.	The vehicle is OK; no further action needed.
77960-S3V-307X	Updated subharness with a noise suppressor is installed.	REPAIR PROCEDURE A
77960-S3V-307X	Updated subharness with the connector taped up and the noise suppressor was removed.	The vehicle is OK; no further action needed.

REPAIR PROCEDURE A

- Cut the wire tie and unbolt the suppressor bracket.

PASSENGER'S SIDE

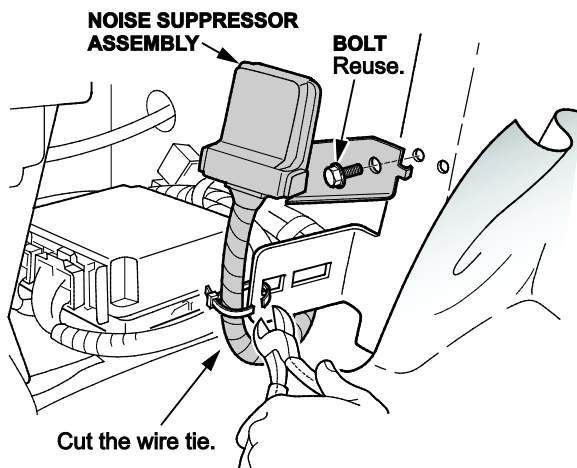

2. On the driver's side, disconnect the clip, then disconnect the two yellow connectors and the blue connector.

DRIVER'S SIDE

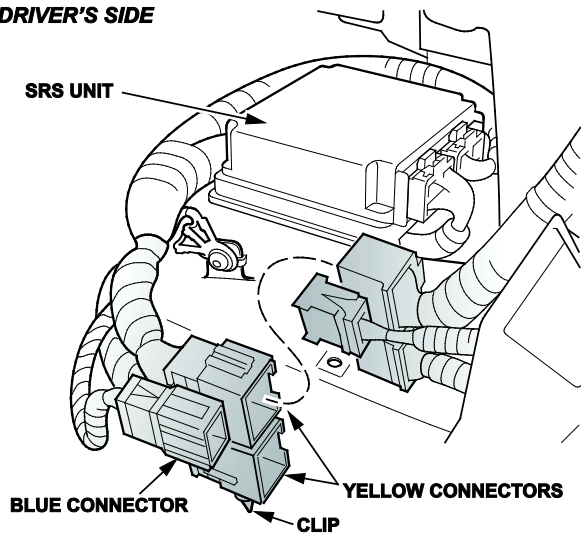

3. Remove the SRS ground wire Torx (T30) bolt.

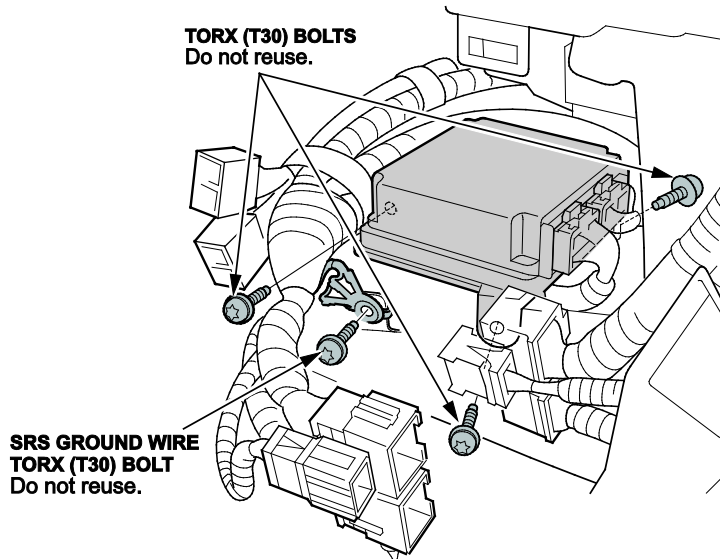

4. Remove the SRS unit by removing the three Torx (T30) mounting bolts.
NOTE: Two of the bolts are accessible from the driver's side, and one is accessible from the front passenger's side.
5. Remove the SRS unit and the subharness from the vehicle.

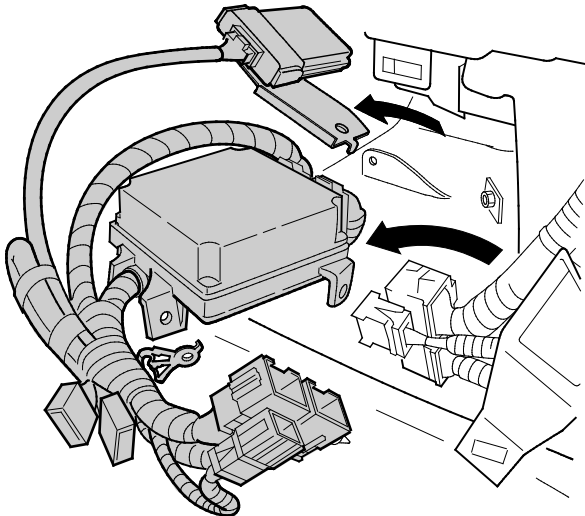

6. Remove the subharness clip from the underside of the SRS unit, then disconnect the subharness from the old SRS unit.

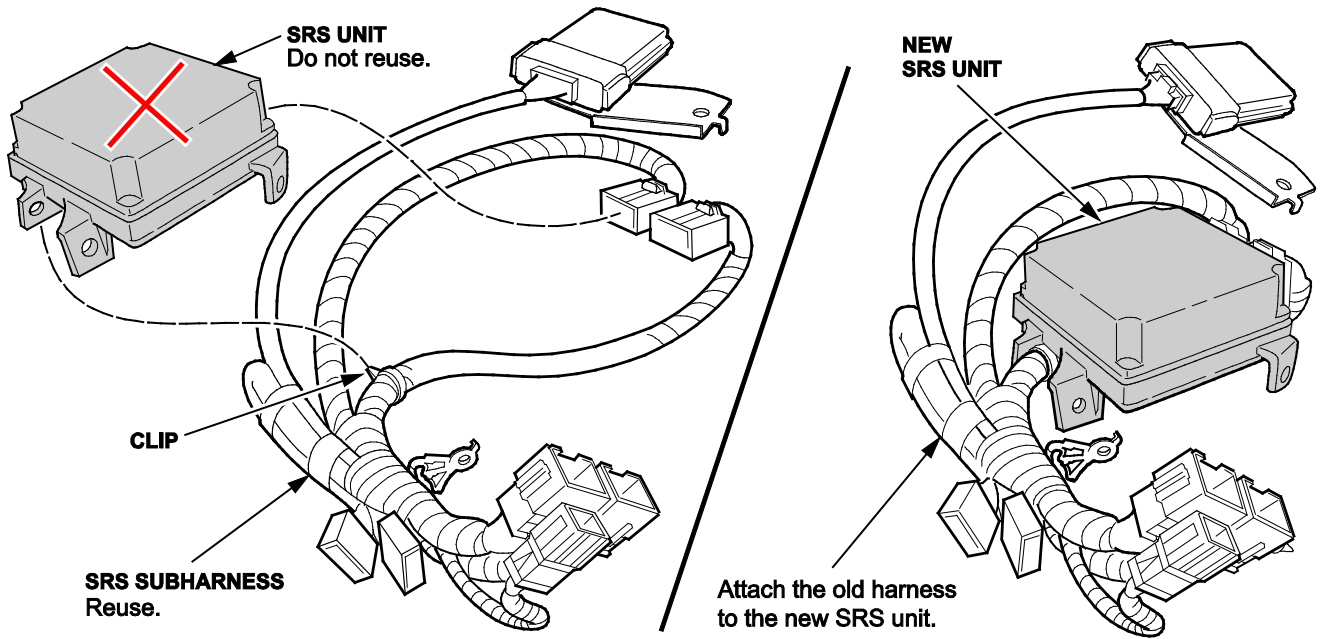

7. Connect the subharness to the new SRS unit P/N 77960-S3V-307.
8. Remove the bracket from the suppressor because you will reuse the bracket. Do not reuse the noise suppressor.

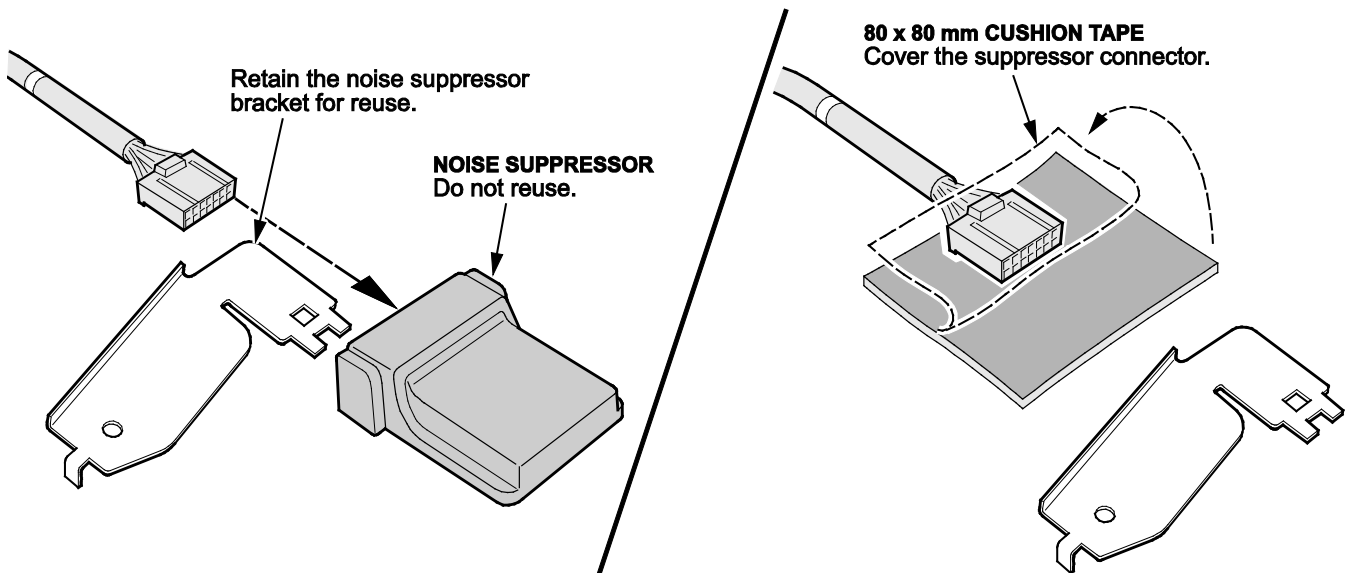

9. Apply a piece of 80 mm x 80 mm cushion tape over the noise suppressor connector as shown.

10. Using a wire tie, secure the old bracket to the harness as shown. In a later step this will hold the harness with the connector pointing down.

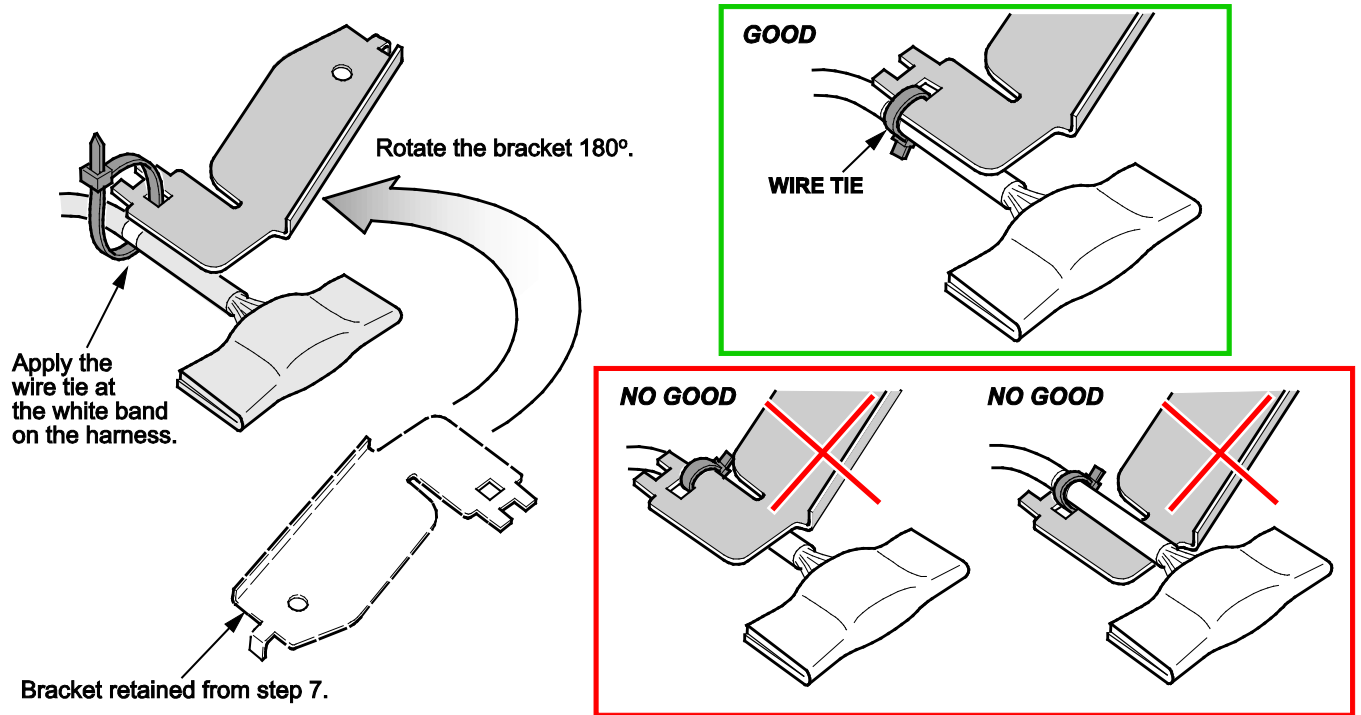

11. Reinstall the new SRS unit and subharness into the vehicle.

- Make sure the SRS unit is squarely against its bracket and install the three new Torx bolts. Torque them to **9.8 N•m (7.2 lb-ft)**.
- Install the fourth new Torx bolt to secure the ground wire and torque it to **9.8 N•m (7.2 lb-ft)**.

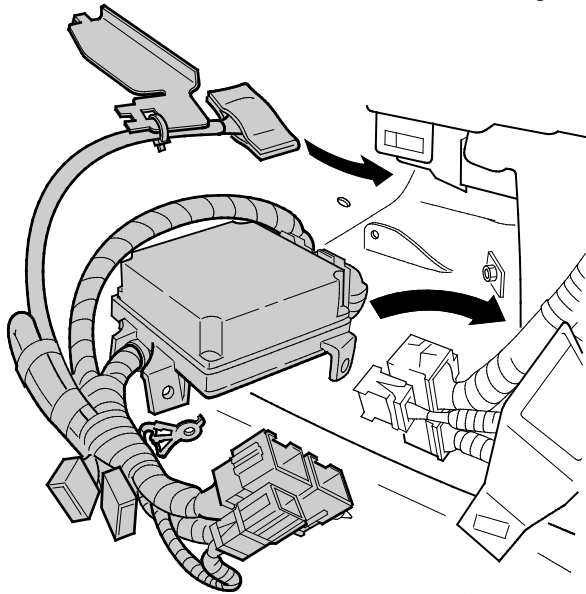

NEW TORX (T30) BOLTS
9.8 N•m (7.2 lb-ft)

**NEW SRS
GROUND WIRE
TORX (T30) BOLT**
9.8 N•m (7.2 lb-ft)

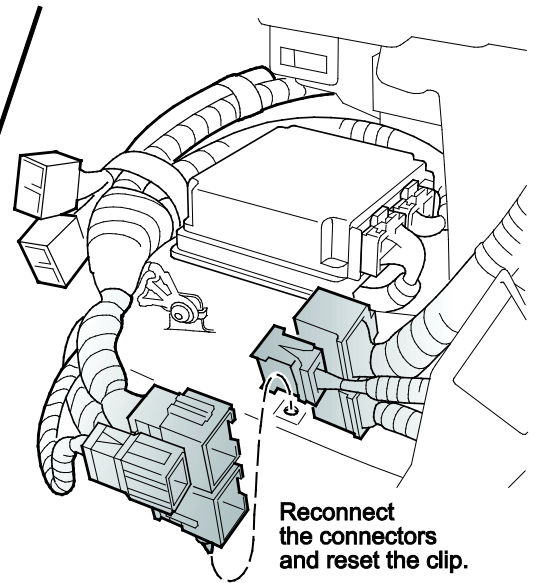
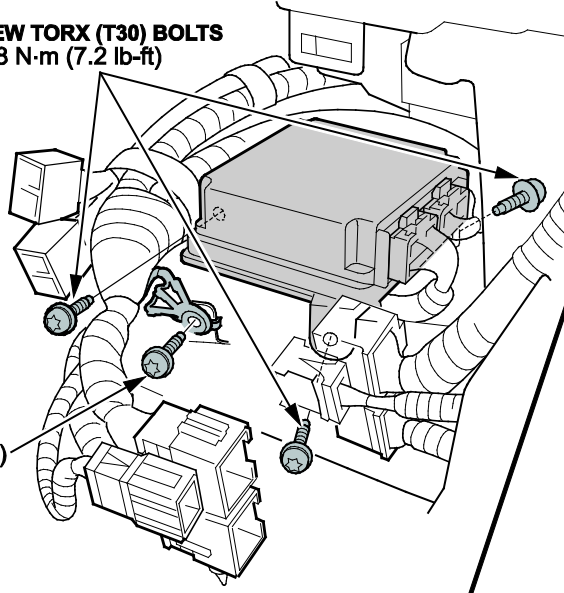

**Reconnect
the connectors
and reset the clip.**

12. Reinstall the bracket using the original bolt as shown. Make sure the connector is pointing downward.

PASSENGER'S SIDE

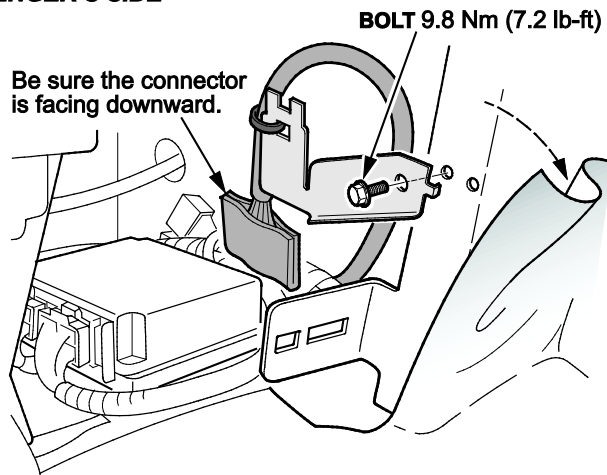

13. Make sure the SRS subharness does not interfere with or rub against the shift cable.

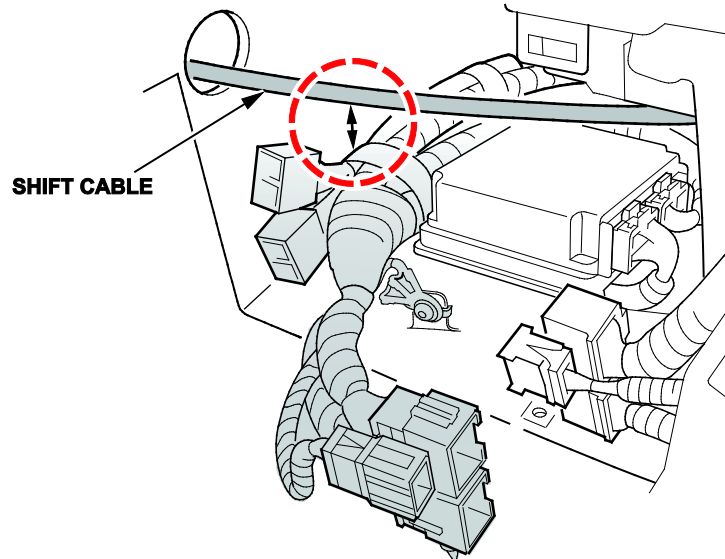

14. Reconnect the two yellow connectors and the blue connector, then reconnect the clip.

15. Reinstall the center console side trim.

16. Reconnect the negative battery cable.

NOTE: Do not initialize the OPDS unit with the HDS.

17. To ready the vehicle for OPDS initialization, do this:

- Move the front passenger's seat back to the most upright position.
- Slide the front passenger's seat all the way back.
- Make sure there is nothing in the front passenger's seat back pocket.
- Make sure there is nothing under the front passenger's seat.

18. To initialize the OPDS, turn the ignition to ON for 1 full minute, turn the ignition off for another minute, then repeat two more times, making sure to wait 1 full minute between turning the ignition key ON or OFF. After cycling the ignition 3 times, turn the ignition to ON and if the SRS indicator comes on for about 6 seconds then goes off, the OPDS initialization is complete.

- If the OPDS is initialized (the indicator light is off) and it passed all the inspection items (INSPECTION PROCEDURE step 1-3), go to step 19.
- If the SRS indicator remains on after the doing the OPDS initialization it is most likely because the interior of the front seat around the OPDS isn't completely dry. After drying the seat, repeat steps 17-18.

To dry the seat, do this:

- Close the vehicle windows and sunroof.
- Start the engine and run the HVAC at its highest heat setting and make sure the A/C is on.
- Aim the vents at the OPDS sensor area.
- If you can't safely run the vehicle to dry the seat, use a shop fan aimed directly at the OPDS sensor.
- Try to initialize the OPDS every 30 minutes. If it doesn't initialize, continue drying the seat and try again in 30 minutes. Most seats will dry within 1.5 hours.

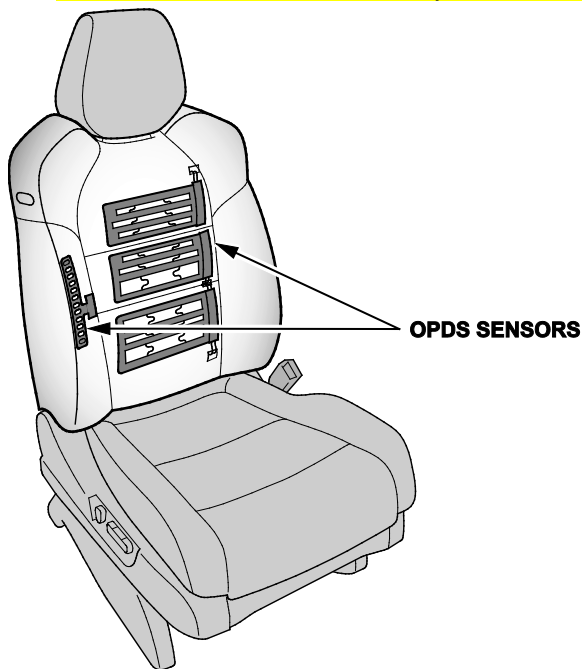

19. Enter the anti-theft codes for the audio and navigation system (if applicable), then enter the client's audio unit presets.

20. Reset the power window control unit:

- Turn the ignition to OFF, then back to ON.
- Press the driver's window switch firmly to the second detent to lower the window all the way down.
- When the window reaches the bottom, continue holding the driver's window switch in the down position for 2 seconds.
- Pull the driver's window switch up and hold it to the second detent to raise the window without stopping.
- When the window reaches the top, continue holding the driver's window switch in the up position for 2 seconds.

21. *Vehicles without navigation:* Set the clock.

22. Do the idle learn procedure.

- Make sure all electrical items (A/C, audio unit, defogger, lights, etc.) are off.
- Start the engine and let it warm up to its normal operating temperature (the cooling fans cycle twice).
- Let the engine idle (throttle closed and all electrical items off) for 10 minutes.

NOTE: Do not initialize the OPDS unit.

REPAIR PROCEDURE B

NOTE: The foam piece and wire tie in the kit are not needed for this repair procedure.

1. Disconnect the two yellow connectors and remove the clip from the floor.

DRIVER'S SIDE

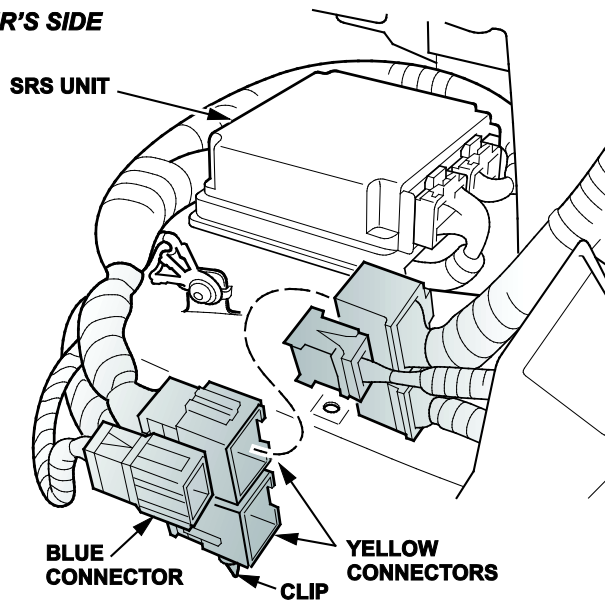

2. Remove the SRS unit by removing the three Torx bolts.

NOTE: Two of the bolts are accessible from the driver's side and one is accessible from the front passenger's side.

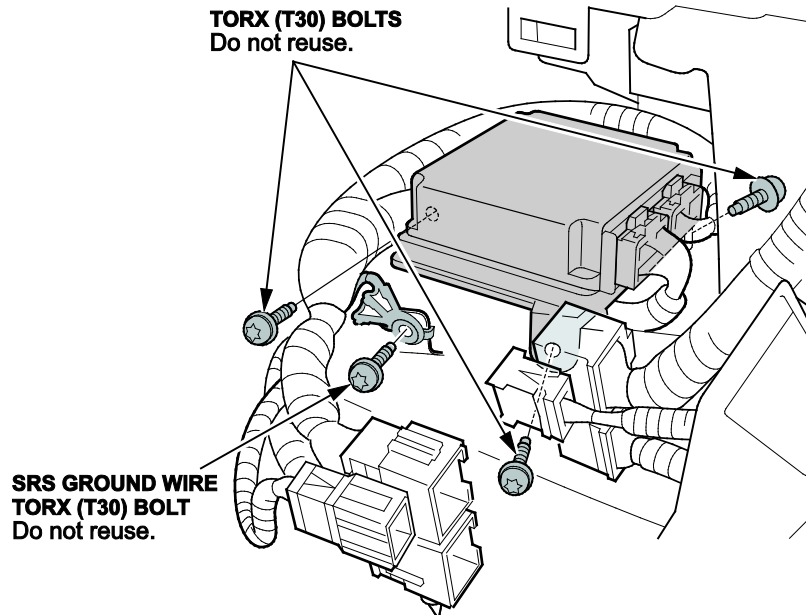

3. Remove the ground wire by removing the Torx bolt.
4. Remove the SRS unit and the subharness from the vehicle.

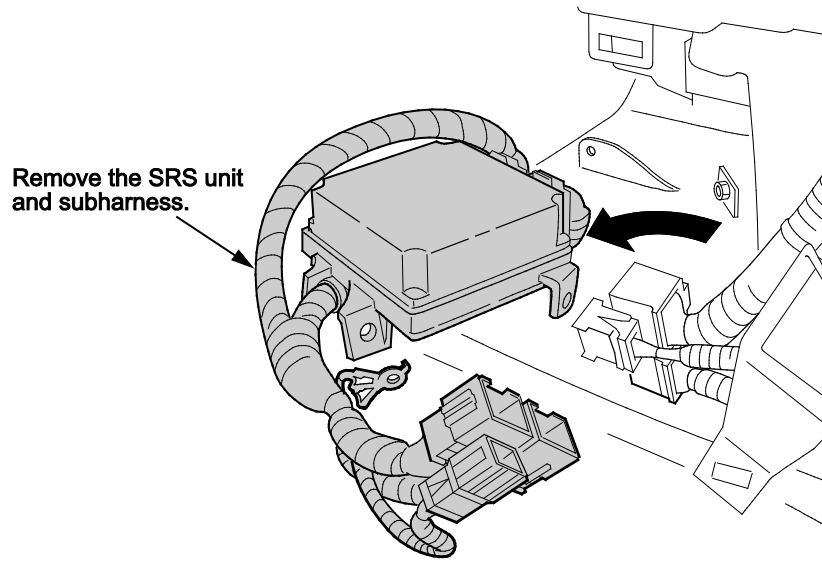

5. Remove the subharness clip from the underside of the SRS unit, then disconnect the subharness from the unit.

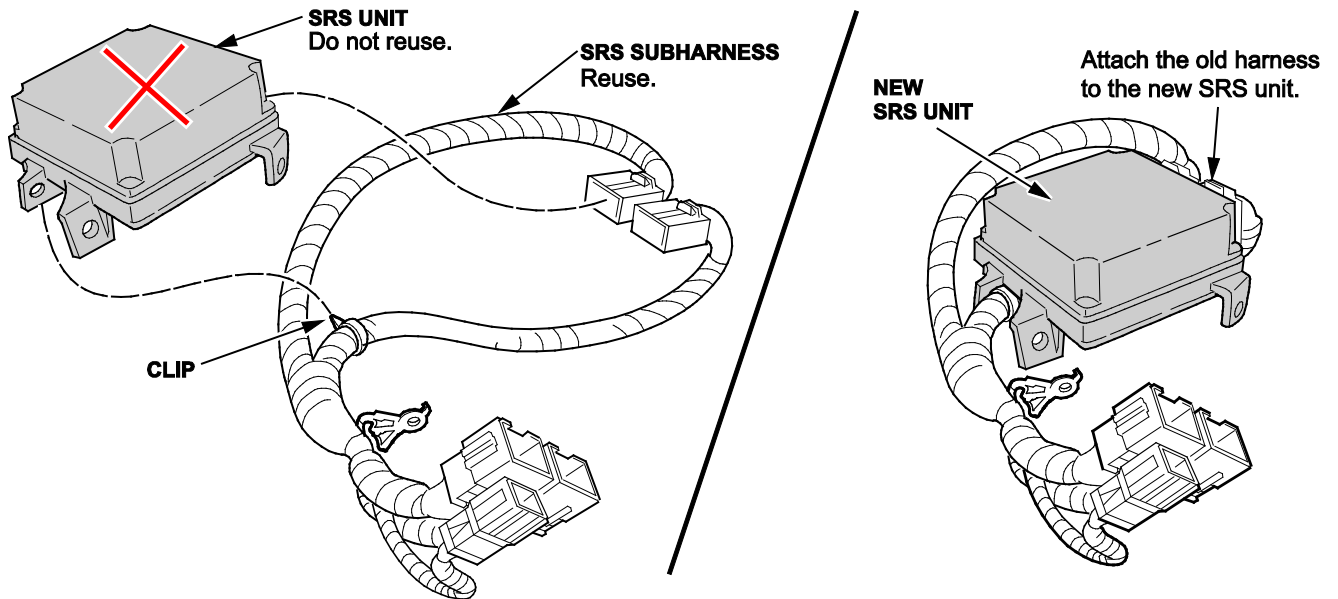

6. Install a new subharness clip onto the original subharness, then connect the subharness to the new SRS unit P/N 77960-S3V-307.

7. Reinstall the new SRS unit and existing SRS subharness into the vehicle with three new Torx bolts and torque them to **9.8 N·m (7.2 lb-ft)**.

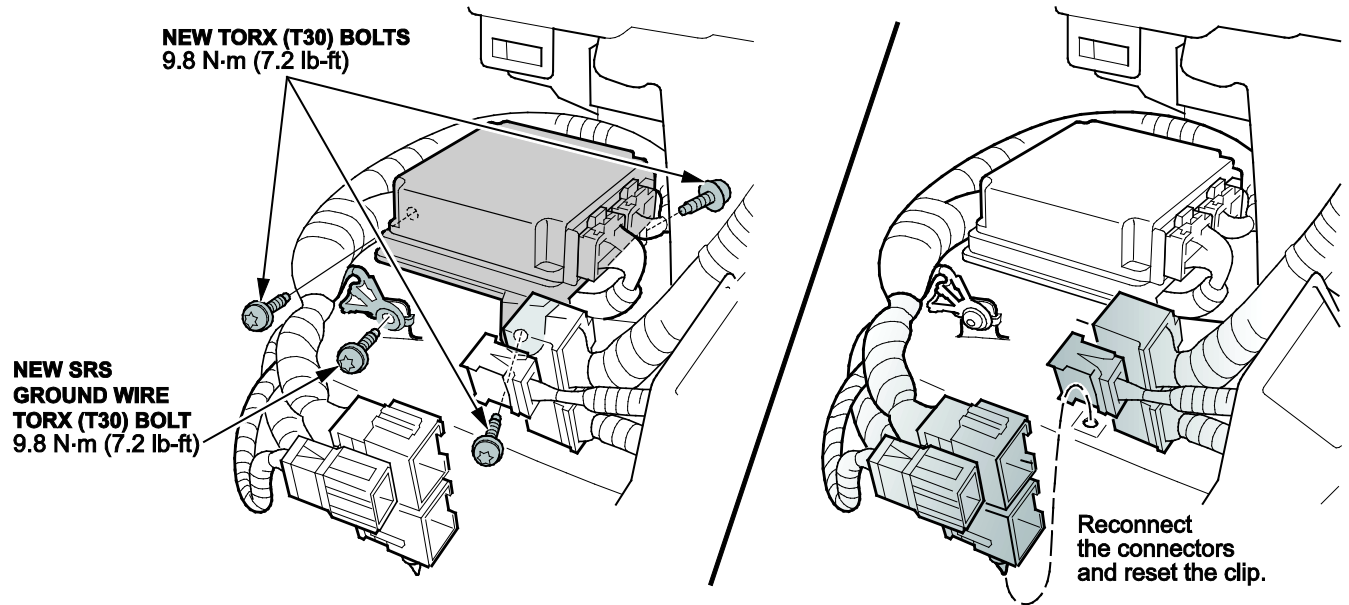

8. Reinstall the ground wire with a new Torx bolt and torque it to **9.8 N·m (7.2 lb-ft)**.
9. Reconnect the connectors and the clip.
10. Reinstall the center console side trim.
11. Reconnect the negative battery cable.

NOTE: Do not initialize the OPDS unit with the HDS.

12. To ready the vehicle for OPDS initialization, do this:

- Move the front passenger's seat back to the most upright position.
- Slide the front passenger's seat all the way back.
- Make sure there is nothing in the front passenger's seat back pocket.
- Make sure there is nothing under the front passenger's seat.

13. To initialize the OPDS, turn the ignition to ON for 1 full minute, turn the ignition off for another minute, then repeat two more times, making sure to wait 1 full minute between turning the ignition key ON or OFF. After cycling the ignition 3 times, turn the ignition to ON and if the SRS indicator comes on for about 6 seconds then goes off, the OPDS initialization is complete.

- If the OPDS is initialized (the indicator light is off) and it passed all the inspection items (INSPECTION PROCEDURE step 1-3), go to step 14.
- If the SRS indicator remains on after the doing the OPDS initialization it is most likely because the interior of the front seat around the OPDS isn't completely dry. After drying the seat, repeat steps 12-13.

To dry the seat, do this:

- Close the vehicle windows and sunroof.
- Start the engine and run the HVAC at its highest heat setting and make sure the A/C is on.
- Aim the vents at the OPDS sensor area.
- If you can't safely run the vehicle to dry the seat, use a shop fan aimed directly at the OPDS sensor.
- Try to initialize the OPDS every 30 minutes. If it doesn't initialize, continue drying the seat and try again in 30 minutes. Most seats will dry within 1.5 hours.

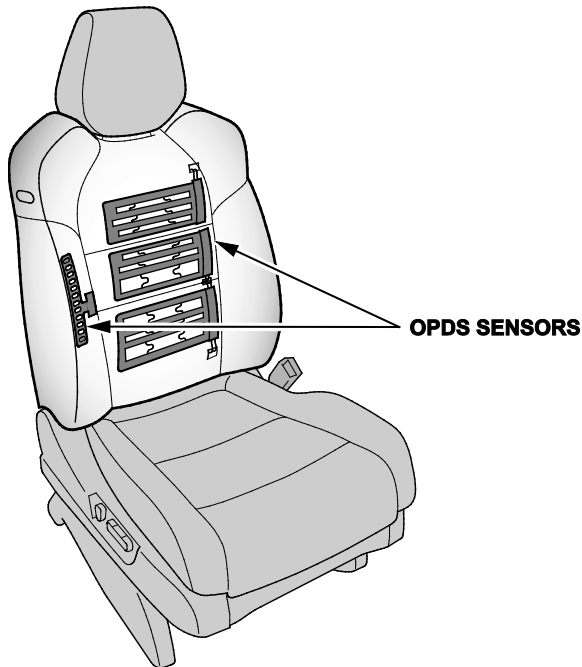

14. Turn the ignition to ON for 1 full minute. The SRS indicator should come on for 6 seconds and go out, but continue to leave the key on the one full minute before turning the ignition OFF.
15. Enter the anti-theft codes for the audio and navigation system (if applicable), then enter the client's audio unit presets.
16. Reset the power window control unit:
- Turn the ignition to OFF, then back to ON.
 - Press the driver's window switch firmly to the second detent to lower the window all the way down.
 - When the window reaches the bottom, continue holding the driver's window switch in the down position for 2 seconds.
 - Pull the driver's window switch up and hold it to the second detent to raise the window without stopping.
 - When the window reaches the top, continue holding the driver's window switch in the up position for 2 seconds.
17. *Vehicles without navigation:* Set the clock.
18. Do the idle learn procedure.
- Make sure all electrical items (A/C, audio unit, defogger, lights, etc.) are off.
 - Start the engine and let it warm up to its normal operating temperature (the cooling fans cycle twice).
 - Let the engine idle (throttle closed and all electrical items off) for 10 minutes.

END