

**TECHNICAL INSTRUCTIONS**  
**FOR**  
**SAFETY RECALL ESG**  
**(Supersedes the E0G campaign)**  
**SRS ECU & SUB HARNESS (FILTER) INSTALLATION**  
**2003 – 2004 MODEL YEAR AVALON**  
**FLOOR MOUNTED SHIFT LEVER**  
**(FRONT BUCKET SEATS)**

The repair quality of covered vehicles is extremely important to Toyota. All dealership technicians performing this procedure are required to successfully complete the most current version of the E-Learning course “Safety Recall and Service Campaign Essentials” To ensure that all vehicles have the repair performed correctly; technicians are required to currently hold at least one of the following certification levels to perform this operation:

- Toyota Expert Electrical
- Master
- Master Diagnostic Technicians

It is the dealership’s responsibility to select technicians with the above certification level or greater to perform this repair. Carefully review your resources, the technician skill level, and ability before assigning technicians to this repair. It is important to consider technician days off and vacation schedules to ensure there are properly trained technicians available to perform this repair at all times.

## I. OPERATION FLOW CHART

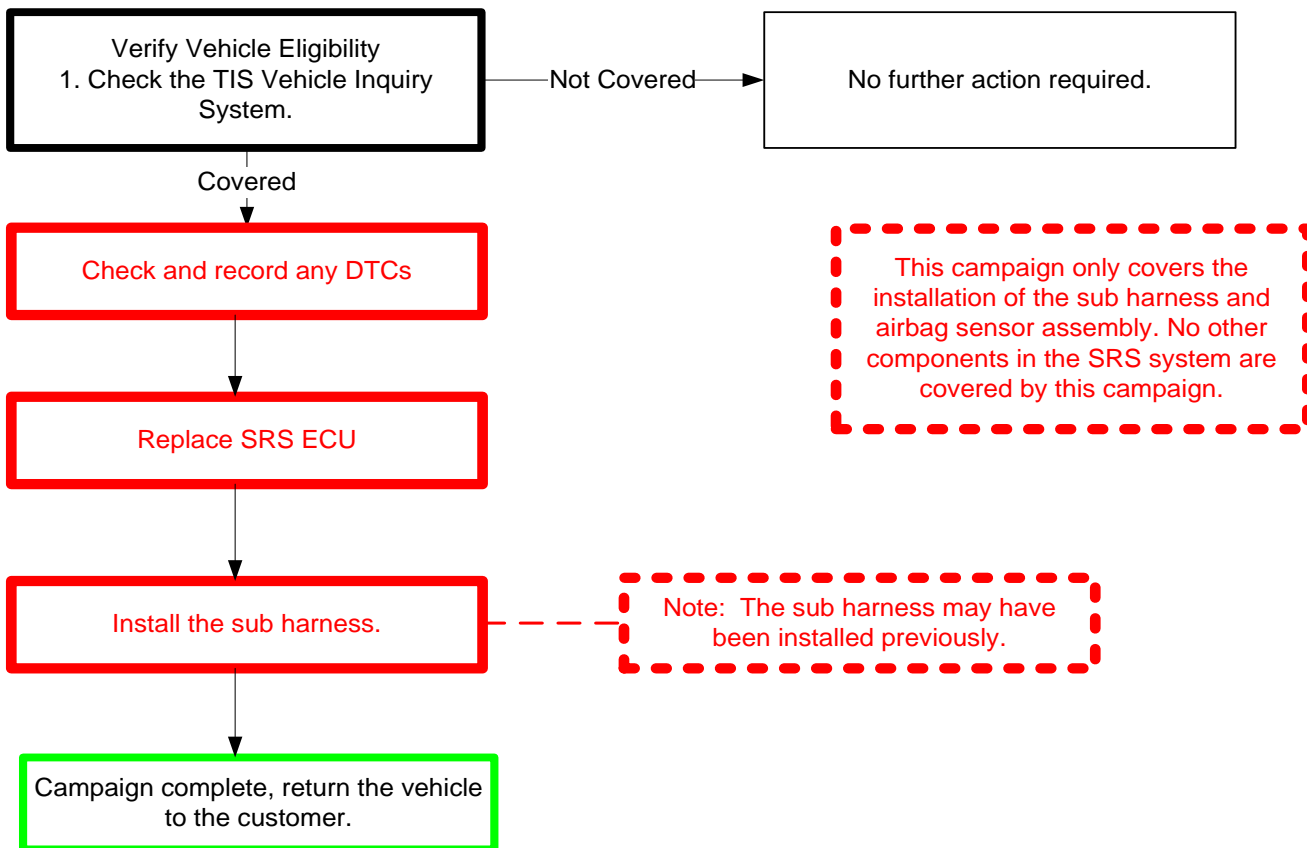

## II. PREPARATION

### A. PARTS

Part Number	Part Description	Quantity									
04004-22241	Airbag Harness Kit*	1									
04004-26207 or 04005-02807	Airbag Sensor Assembly (SRS ECU)	1									
<p>* <b>Do Not Order</b> if the Sub Harness was previously installed. Check vehicle Service History to confirm. The kit above includes the following parts.</p> <table border="1" style="margin-left: auto; margin-right: auto;"> <tbody> <tr> <td style="text-align: center;">-</td> <td style="text-align: center;">Airbag sub harness</td> <td style="text-align: center;">1</td> </tr> <tr> <td style="text-align: center;">-</td> <td style="text-align: center;">Water guard sheet</td> <td style="text-align: center;">1</td> </tr> <tr> <td style="text-align: center;">-</td> <td style="text-align: center;">Cable tie</td> <td style="text-align: center;">7*</td> </tr> </tbody> </table> <p>*2 extra ties are provided as a supplement.</p>			-	Airbag sub harness	1	-	Water guard sheet	1	-	Cable tie	7*
-	Airbag sub harness	1									
-	Water guard sheet	1									
-	Cable tie	7*									

**NOTE: If the Airbag Harness Kit has been previously installed, you will also need 1 cable tie.**

## B. TOOLS & EQUIPMENT

- Standard hand tools
- Torque wrench
- Techstream
- Tape measure
- Vinyl tape

**SST – This is an essential special service tool that the dealership should have.**

Part Number	Part Name	Quantity
00002-06000-01	Plastic pry Tool Set	1

## III. BACKGROUND

The Electronic Control Module (ECM) for the Supplemental Restraint System (SRS) in these vehicles could have been manufactured with integrated circuits that are susceptible to internal short circuiting when exposed to certain electrical noise from various vehicle electrical components. If internal short circuiting occurs, the front airbag(s) and/or seat belt pre-tensioners could inadvertently deploy. An airbag that deploys inadvertently can, under some circumstances, increase the risk of minor injury and the possibility of a crash.

### NOTE:

- Check the TIS Vehicle Inquiry System to confirm the VIN is involved in this Safety Recall, and that the campaign has not already been completed prior to dealer shipment or by another dealer.
- **TMS warranty will not reimburse dealers for repairs conducted on vehicles that are not affected or were completed by another dealer.**

# IV. COMPONENTS

## MODELS WITH FLOOR-MOUNTED SHIFT LEVER

For installation of sub wire harness

INSTRUMENT PANEL FINISH  
PANEL LOWER LH

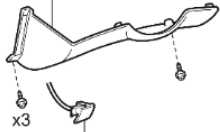

HOOD LOCK  
CONTROL LEVER



FRONT FLOOR  
FOOTREST

COWL SIDE TRIM  
SUB-ASSEMBLY LH

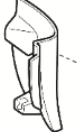

FRONT DOOR SCUFF  
PLATE LH

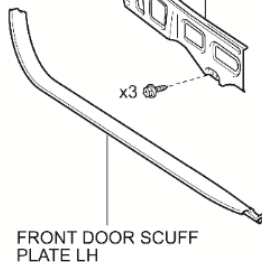

N\*m (kgf\*cm, ft.\*lbf) : Specified torque

INSTRUMENT PANEL TO COWL  
BRACE SUB-ASSEMBLY

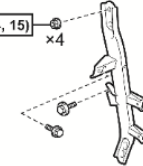

FRONT CONSOLE BOX

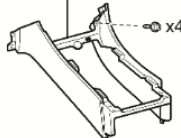

FLOOR CARPET  
BRACKET LH

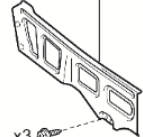

CONSOLE UPPER PANEL  
SUB-ASSEMBLY



AIR DUCT REAR No.2



### Components to be installed:



SUB WIRE HARNESS

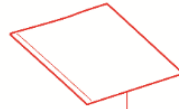

WATER GUARD SHEET



CABLE TIE  
x7  
(Ind. spares)

INSTRUMENT PANEL FINISH  
PANEL LOWER RH

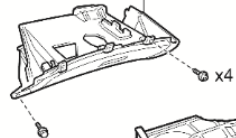

INSTRUMENT PANEL UNDER  
COVER SUB-ASSEMBLY No.2

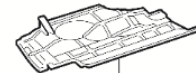

CONSOLE BOX  
HOLE COVER



FRONT DOOR SCUFF  
PLATE RH

CONSOLE UPPER REAR  
PANEL SUB-ASSEMBLY



CONSOLE BOX  
PLATE



REAR CONSOLE BOX  
ASSEMBLY

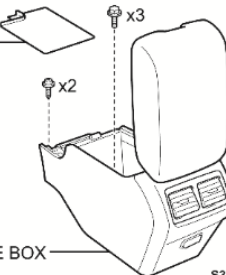

S37286b5

## For replacement of airbag sensor assembly

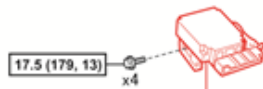

● AIRBAG SENSOR ASSEMBLY

● : Component to be replaced

N\*m (kgf\*cm, ft.\*lbf) : Specified torque

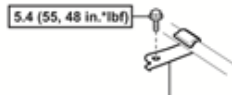

PARKING BRAKE  
CABLE BRACKET

S37287a5

NOTE: The vehicle could have one of the following scenarios:

Current Status	Repair
No prior repair and E0G campaign shows not completed	Replace SRS ECU and install Airbag Harness Kit
Airbag Harness Kit previously installed under E0G	Replace SRS ECU

## V. WORK PROCEDURE

### 1. PREFORM A HEALTH CHECK



This campaign only covers the installation of the sub harness and Airbag Sensor Assembly (SRS ECU). No other components in the SRS system are covered by this campaign.

- a) Using Techstream, perform a health check to confirm if there are any DTCs present in the system (**Both current or history**).

#### NOTES:

- Ensure that the Techstream software is 9.2 or higher.
- On the “connect to vehicle” screen, enter the VIN number to ensure that the vehicle information is uploaded to TIS.
- **A Health check must be performed on every vehicle.** Record any DTCs as they are used to confirm the vehicles final state after repair and aid in any additional dicussions needed with the customer.

2. SET THE PARKING BRAKE
3. RECORD AUDIO, SEAT, STEERING COLUMN AND CLIMATE CONTROL SETTINGS
4. MOVE THE DRIVER AND PASSENGER SEAT TO THE REAR MOST POSITION
5. ADJUST THE STEERING COLUMN TO THE UPPER MOST POSTION
6. DISCONNECT THE NEGATIVE BATTERY TERMINAL



- Wait at least 90 seconds after disconnecting the cable from the negative battery terminal to prevent airbag and seat belt pre-tensioner deployment.
- Follow all precautions as outlined on TIS before servicing the SRS system.

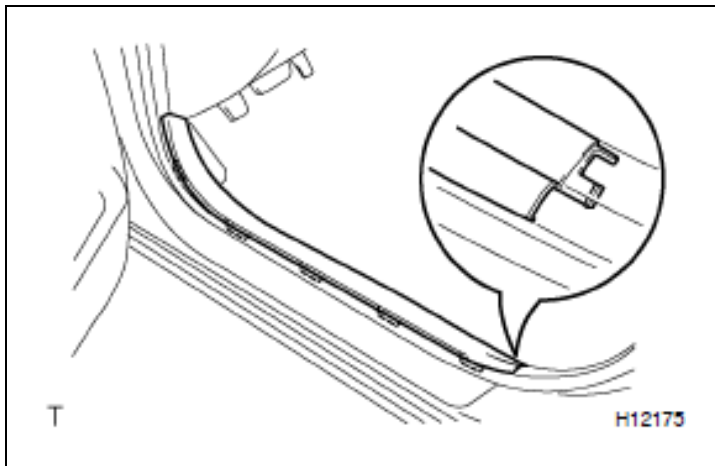

### 7. REMOVE THE CENTER CONSOLE

- a) Remove the left and right front door scuff plate.
- b) Remove the instrument panel under cover sub-assembly No.2.

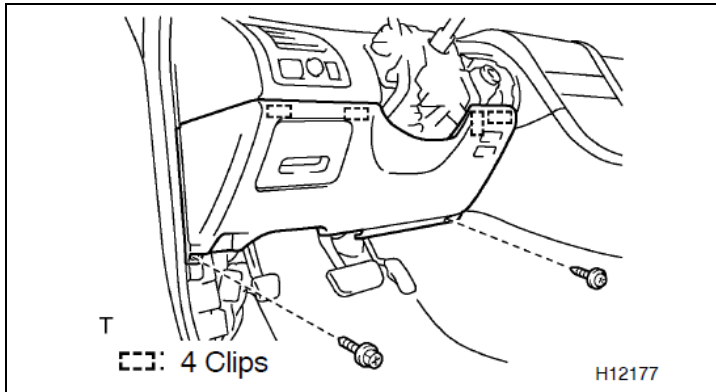

- c) Remove the No. 1 lower panel.
  - 1) Remove the 2 screws and hood lock release lever.
  - 2) Using a plastic pry tool, remove the No. 1 lower panel.
- d) Remove the cowl side trim sub-assembly LH.
- e) Remove the left front floor footrest.

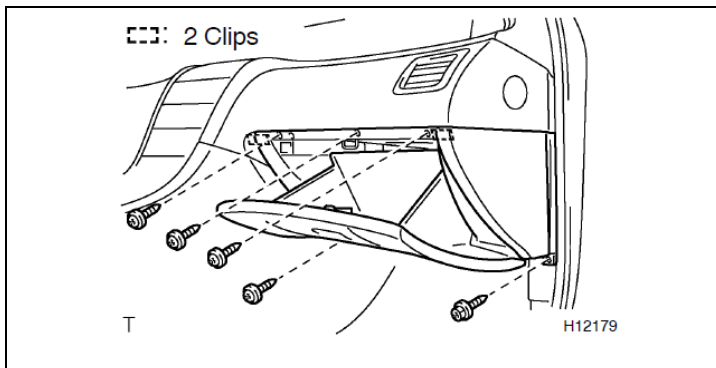

- f) Remove the glove box.
  - 1) Remove the 5 screws.
  - 2) Using a plastic pry tool, remove the lower panel.

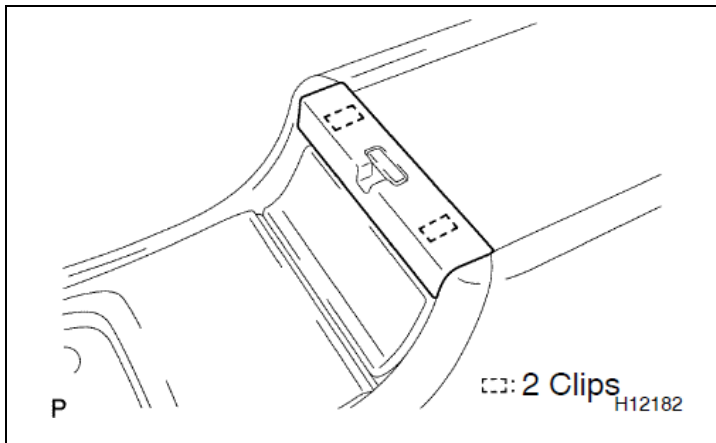

- g) Console upper rear panel sub-assembly
  - 1) Using a plastic pry tool, remove the upper rear console panel.
- h) Remove the front ash tray.

**Note: Do not pull on the ash tray door.**

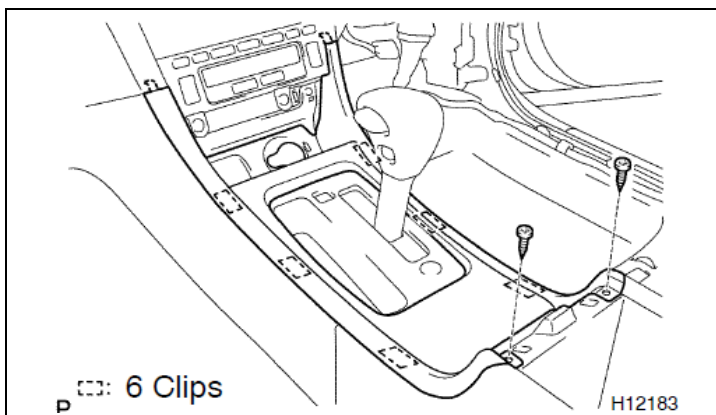

- i) Remove the console upper panel.
  - 1) Remove the 2 screws.
  - 2) Using a plastic pry tool, remove the upper console panel.
- j) Remove the cup holder.

k) Rear console box.

- 1) Remove the console box plate.
- 2) Remove the 2 screws.
- 3) Remove the 3 bolts.
- 4) Remove the rear console box.
- 5) Lift the console box and disconnect the connector.

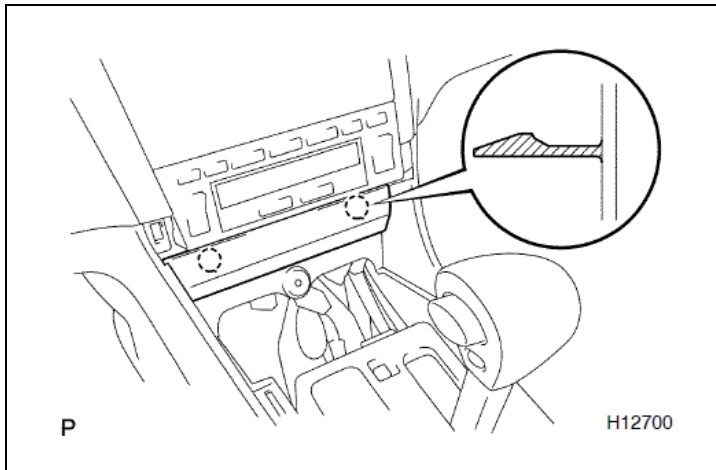

l) Remove the console box hole cover.

- 1) Using a plastic pry tool, remove the console box hole cover.

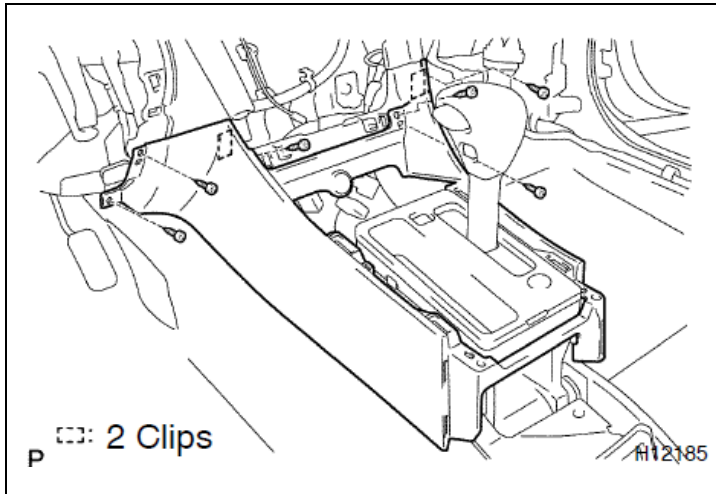

m) Remove the front console box.

- 1) Remove the 6 screws.
- 2) Using a plastic pry tool, remove the front console box.

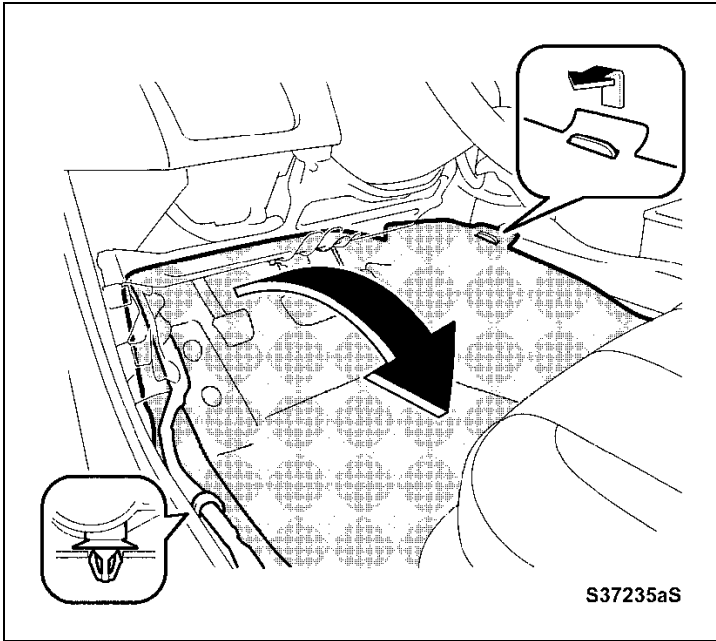

**8. REMOVE THE LEFT FLOOR CARPET BRACKET**

- a) Disengage the claw for the floor wire harness clamp.
- b) Unhook the carpet from the bracket.
- c) Fold the carpet back half way.

**NOTE: Wear gloves to protect your hand from sharp edges.**

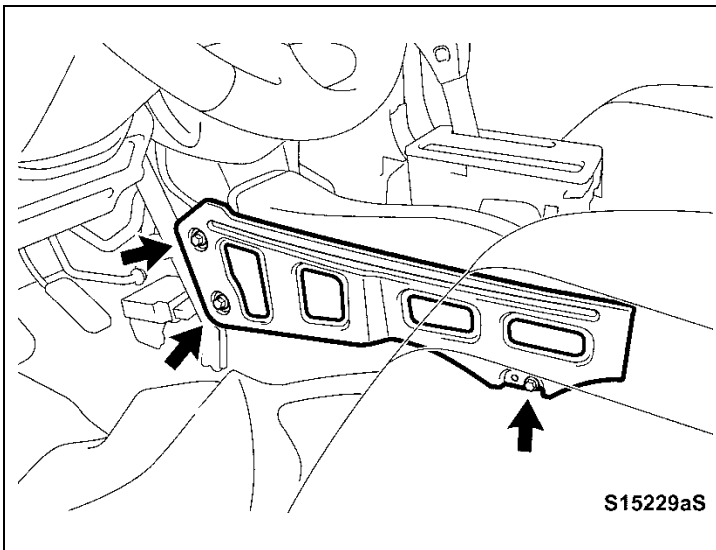

- d) Remove the 3 screws.
- e) Remove the bracket.

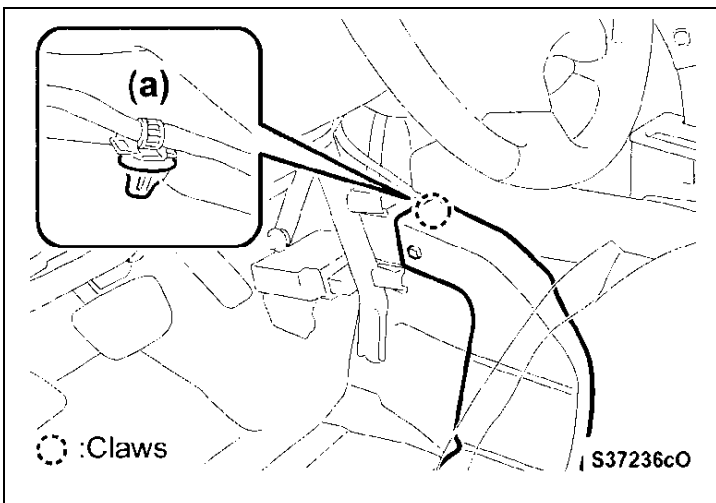

**9. REMOVE REAR DUCT No. 2**

- a) Unfasten the wire harness clamp.



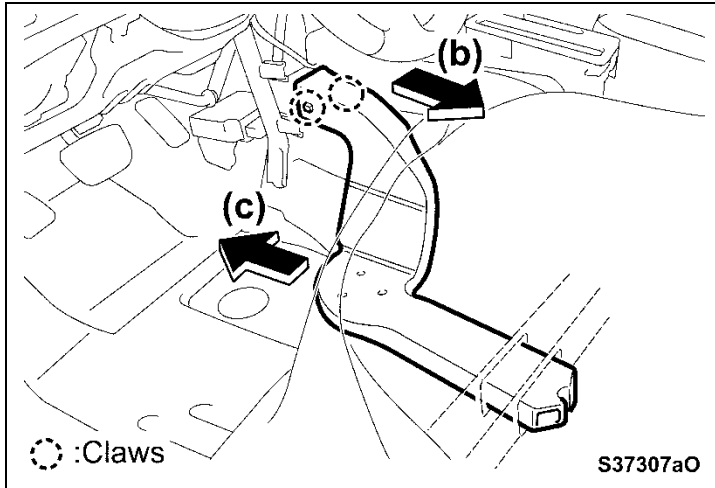

- b) Move the air duct towards the rear to disengage the 2 claws.
- c) Pull the air duct towards the front and remove it from the vehicle.

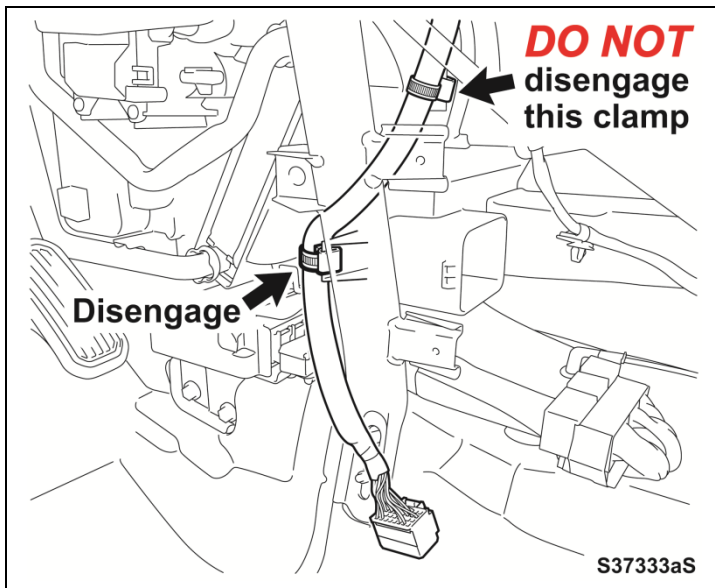

- d) Disengage the dash wire harness clamp from the HVAC unit as shown.

**NOTE: If sub-harness was previously installed proceed to Step e.**

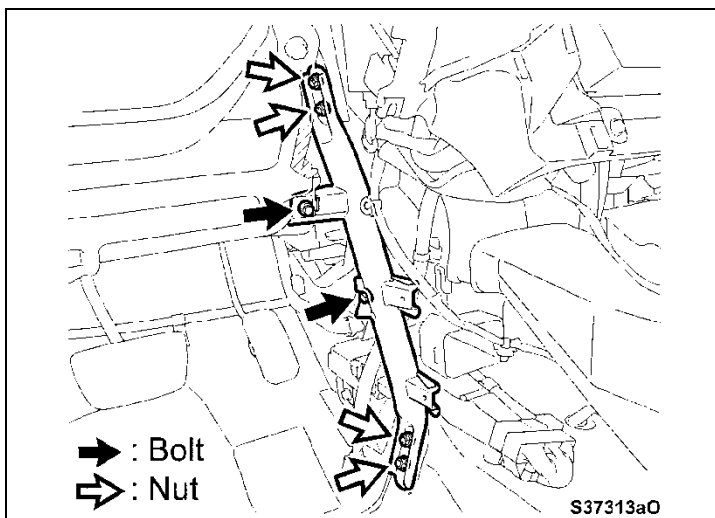

- e) Remove the following from the left dash brace:
  - 4 nuts
  - 2 bolts

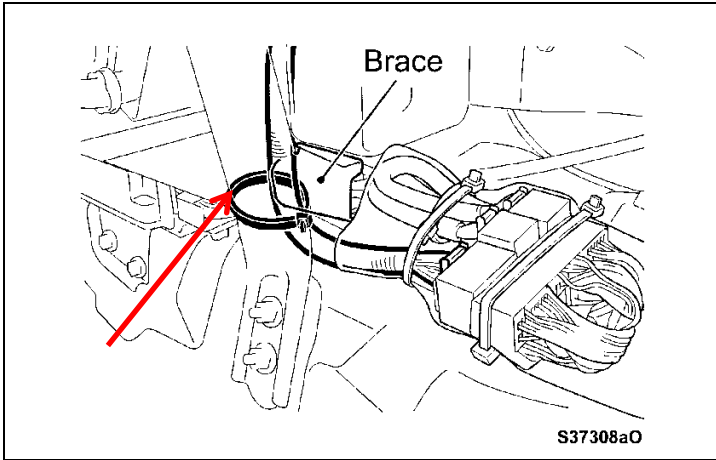

**NOTE:** If the sub-harness has been previously installed you will need to cut the tie wrap holding the harness to the dash brace.

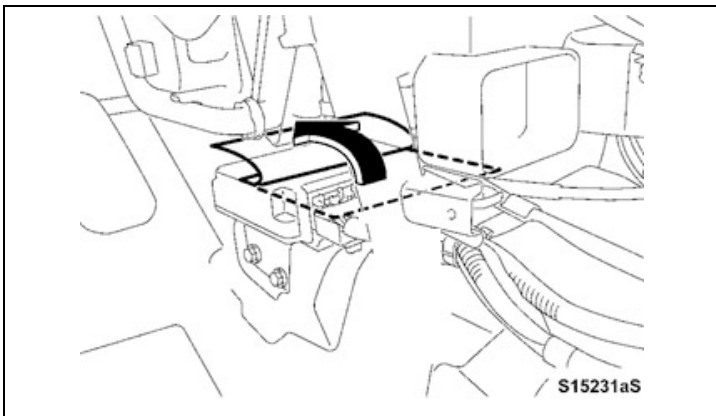

**10. DISCONNECT THE HARNESS'S FROM THE AIRBAG ECU**

- a) Fold back the plastic sheet that covers the connectors.

**STOP** DO NOT remove the plastic sheet from the airbag ECU

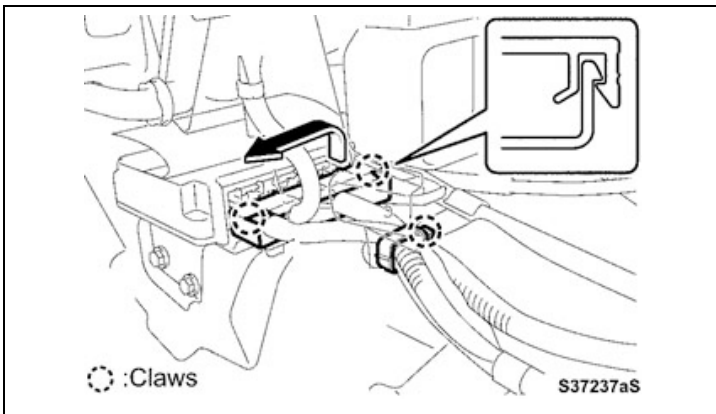

- b) Disengage the 2 claws for the wire harness bracket.
- c) Disengage the claw for the wire harness clamp.

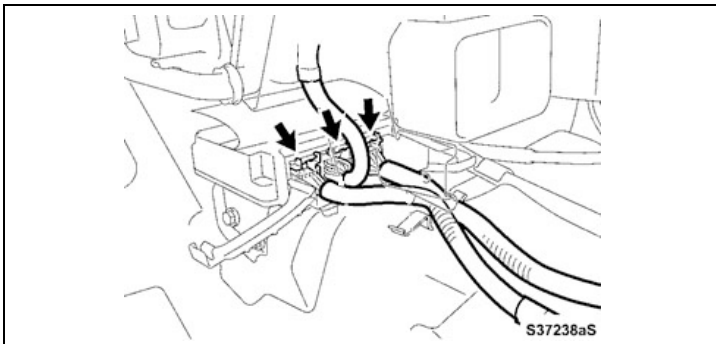

- d) Disconnect the following from the airbag ECU:
- Left Floor Harness
  - Dash Harness
  - Right Floor Harness

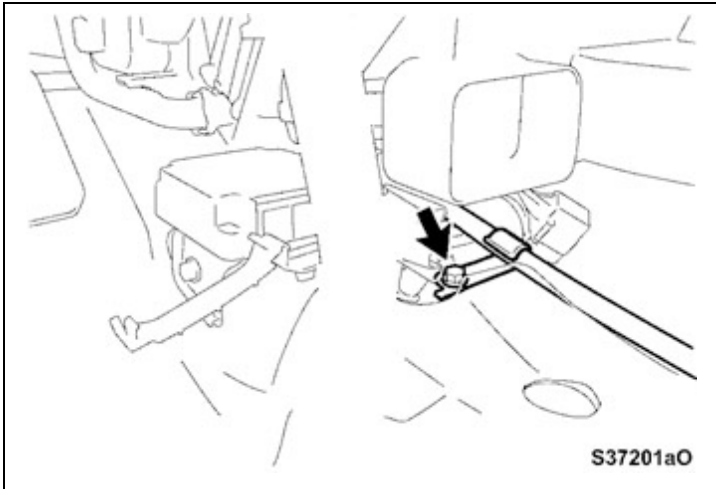

## 11. AIRBAG ECU REPLACEMENT

a) Remove the parking brake cable bracket.

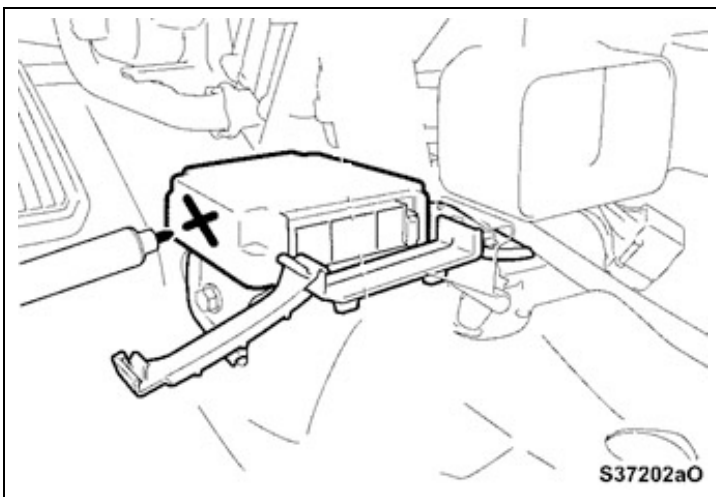

b) Mark the old airbag ECU so it is not reused.

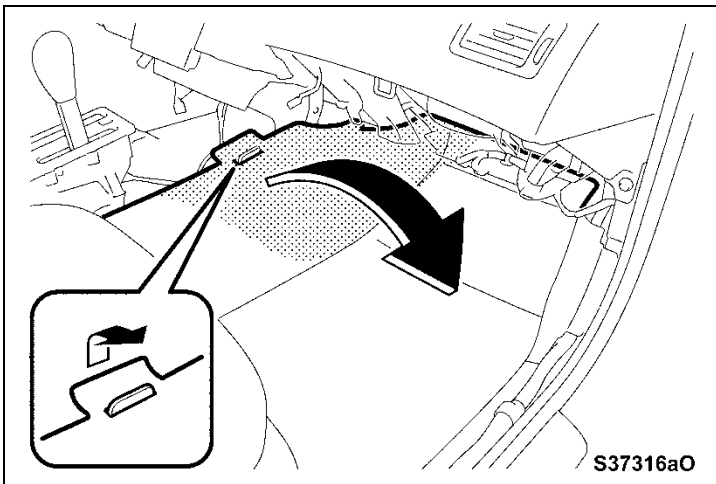

c) Unhook the carpet on the right side from the bracket.

d) Fold the carpet back half way to access the airbag ECU.

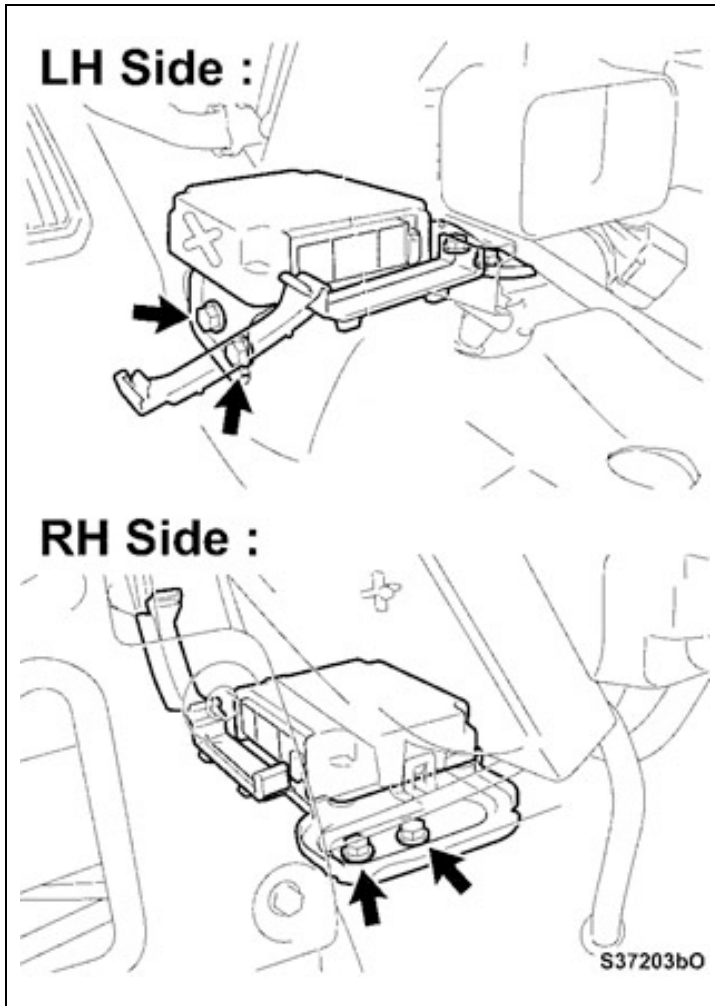

- e) Remove the 4 bolts.
- f) Remove the airbag ECU.

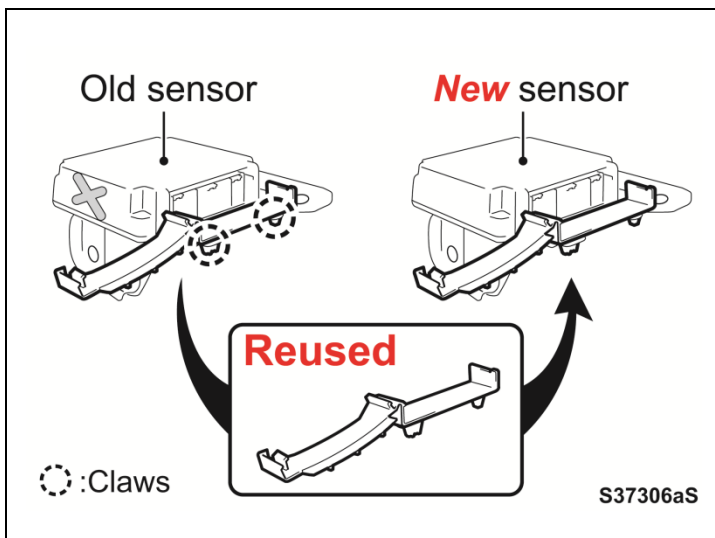

- g) Remove the wire harness bracket from the original ECU.
- h) Reinstall the wire harness bracket onto the new ECU.

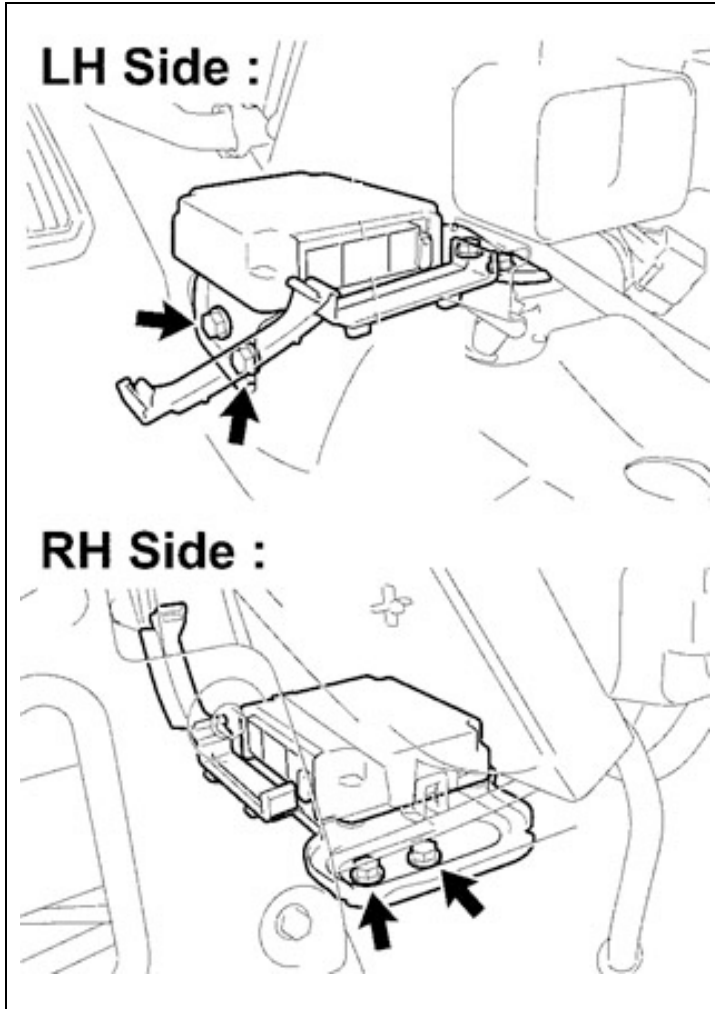

**Do not drop or strike the new airbag ECU.**

- i) Install the new airbag ECU.
- j) Install the 4 bolts.  
Torque: 17.5 N•m (179 kgf•cm, 13 ft.•lb)

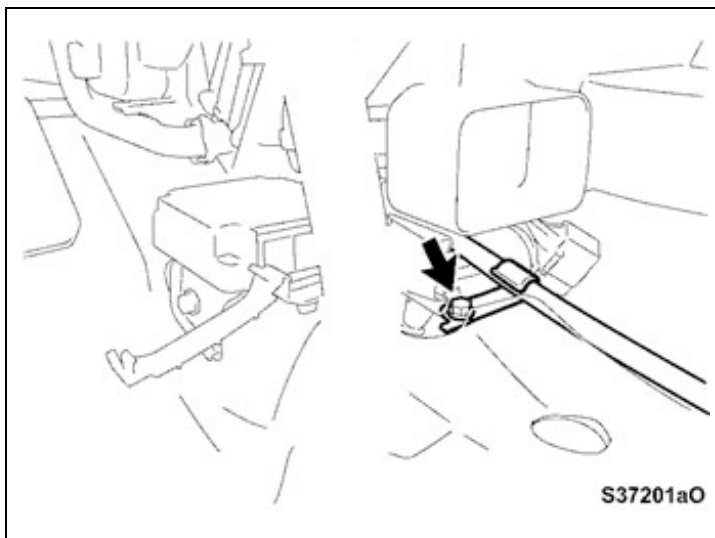

- k) Reinstall the parking brake cable bracket.  
Torque: 5.4 N•m (55 kgf•cm, 48 in.•lb)

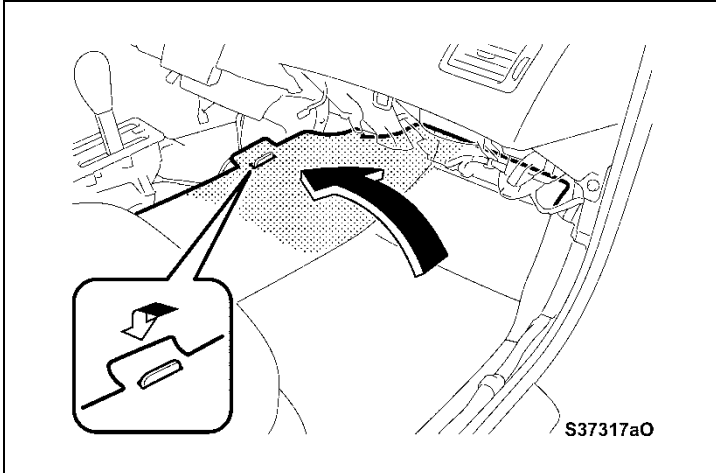

l) Return the right front carpet to its original position.

**Continue to Step 12.**



**All vehicles will receive a new Sub Harness. If the Sub Harness was previously installed, perform Steps 12a - d.**

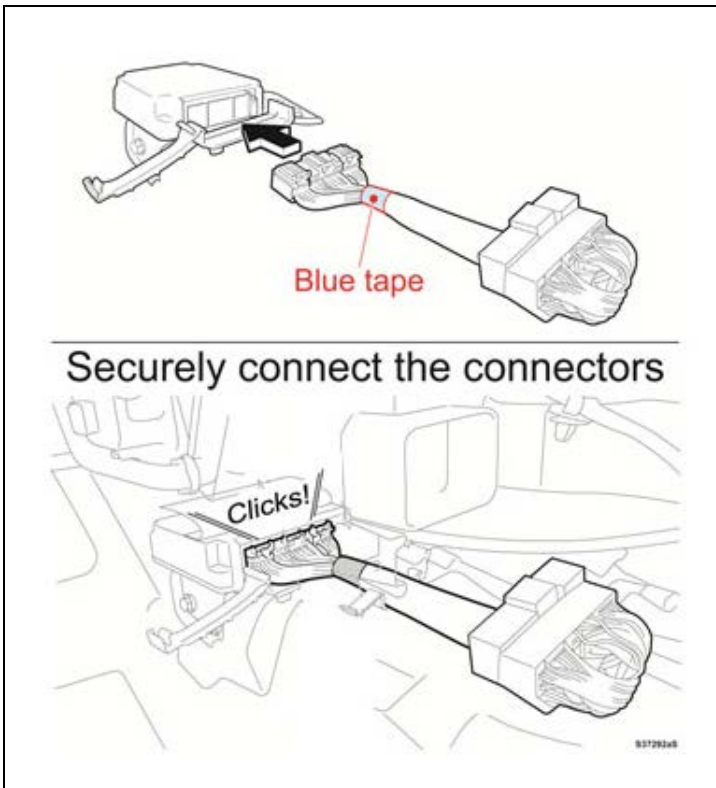

## 12. INSTALL SUB WIRE HARNESS

a) Connect or reconnect the 3 connectors of the sub wire harness to the airbag ECU.

**NOTE: Ensure that the sub wire harnesses with the connectors near the blue tape are fully engaged into the ECU.**

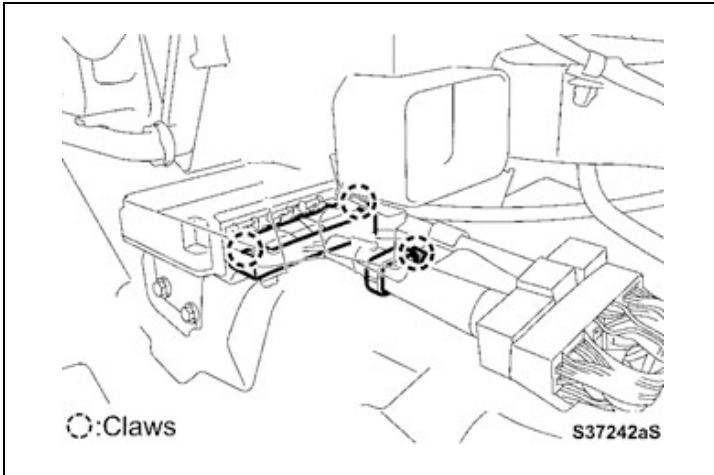

- b) Reengage the 2 claws for the wire harness bracket.
- c) Reinstall the wire harness clamp.

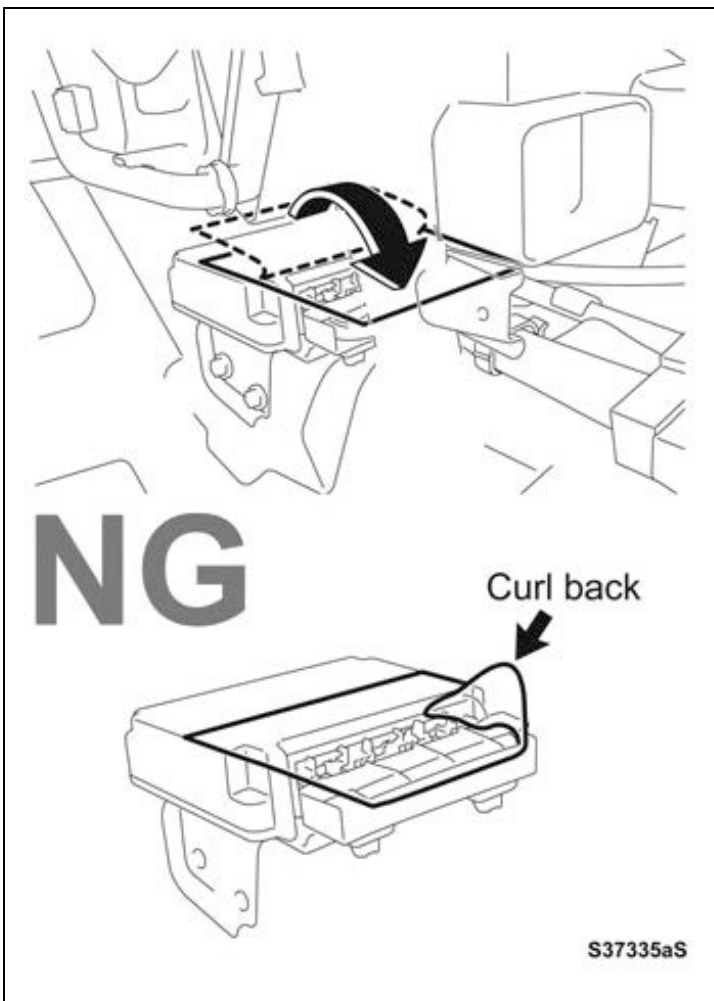

- d) Unfold the plastic sheet that is attached to the airbag ECU so that it covers the connectors and sub harness.

**NOTE:** Ensure that the plastic sheet is positioned correctly and is not curled back on itself. The plastic sheet protects the ECU and connectors in case of water condensation from the HVAC unit.

**STOP** If the Sub Harness has already been installed, proceed to step 13d.

### 13. WIRE HARNESS RE-ROUTING



Wire harness re-routing is necessary to ensure that there is no tension on the harness and that the connectors are protected in case of water condensation from the HVAC unit.

**Before the vehicle wire harness is re-routed:**

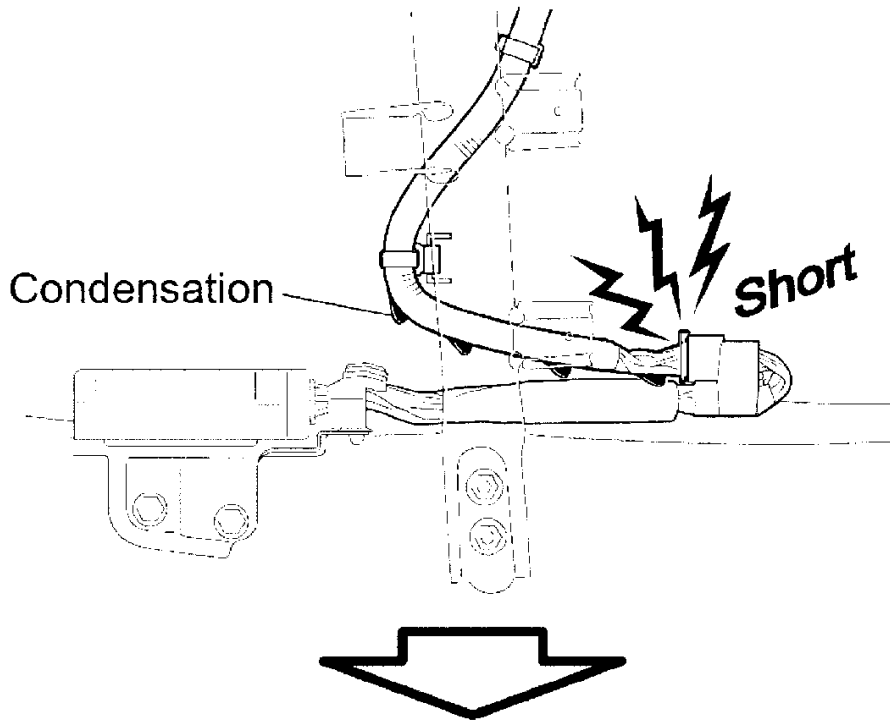

**After the vehicle wire harness is re-routed:**

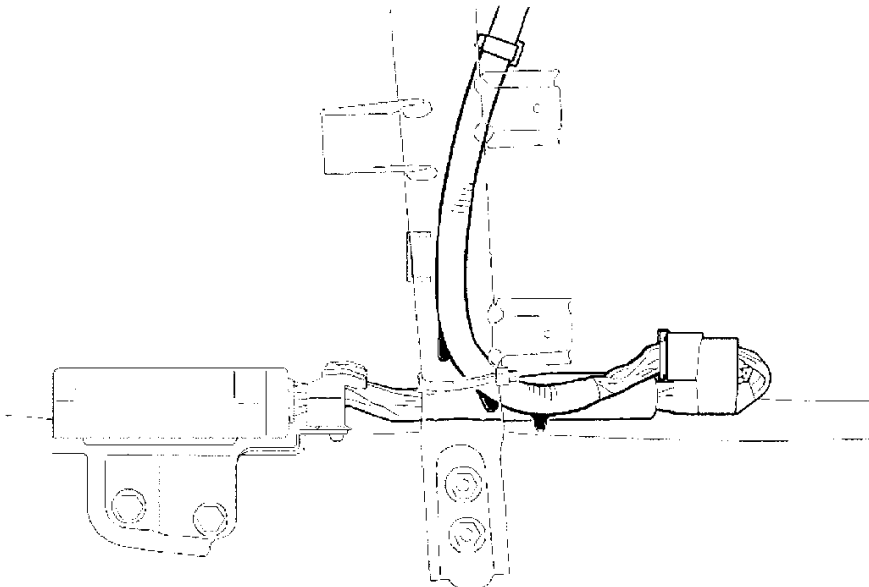

S37311a0



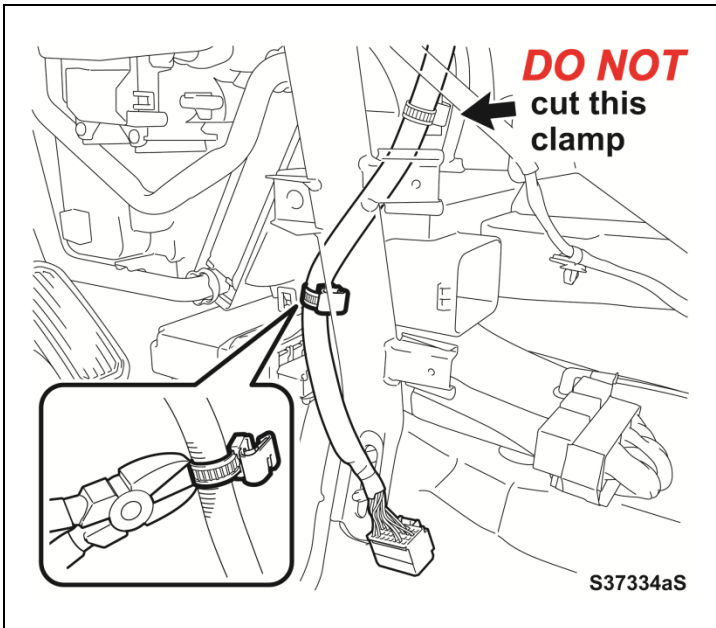

a) Cut and remove the clamp from the dash harness.

**NOTE:** Do not damage the dash harness.

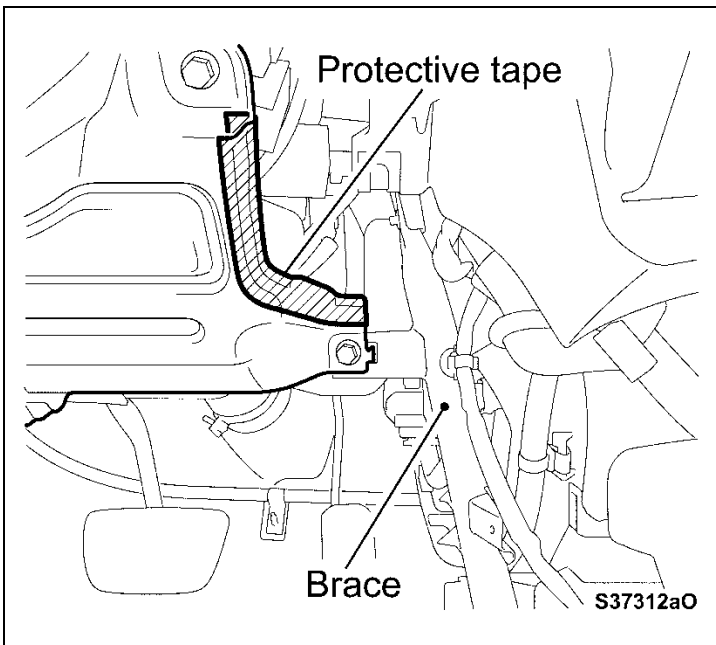

b) Attach tape to the area shown as protection from sharp edges.

c) Re-route the dash harness as shown.

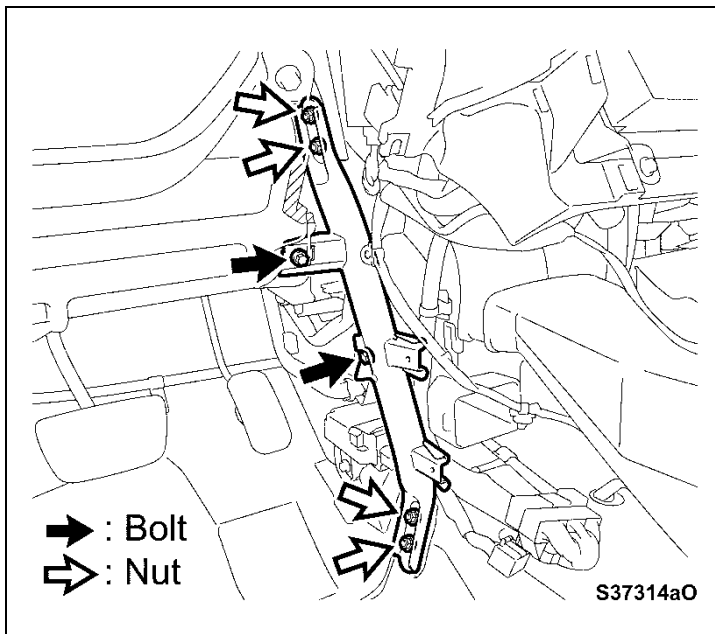
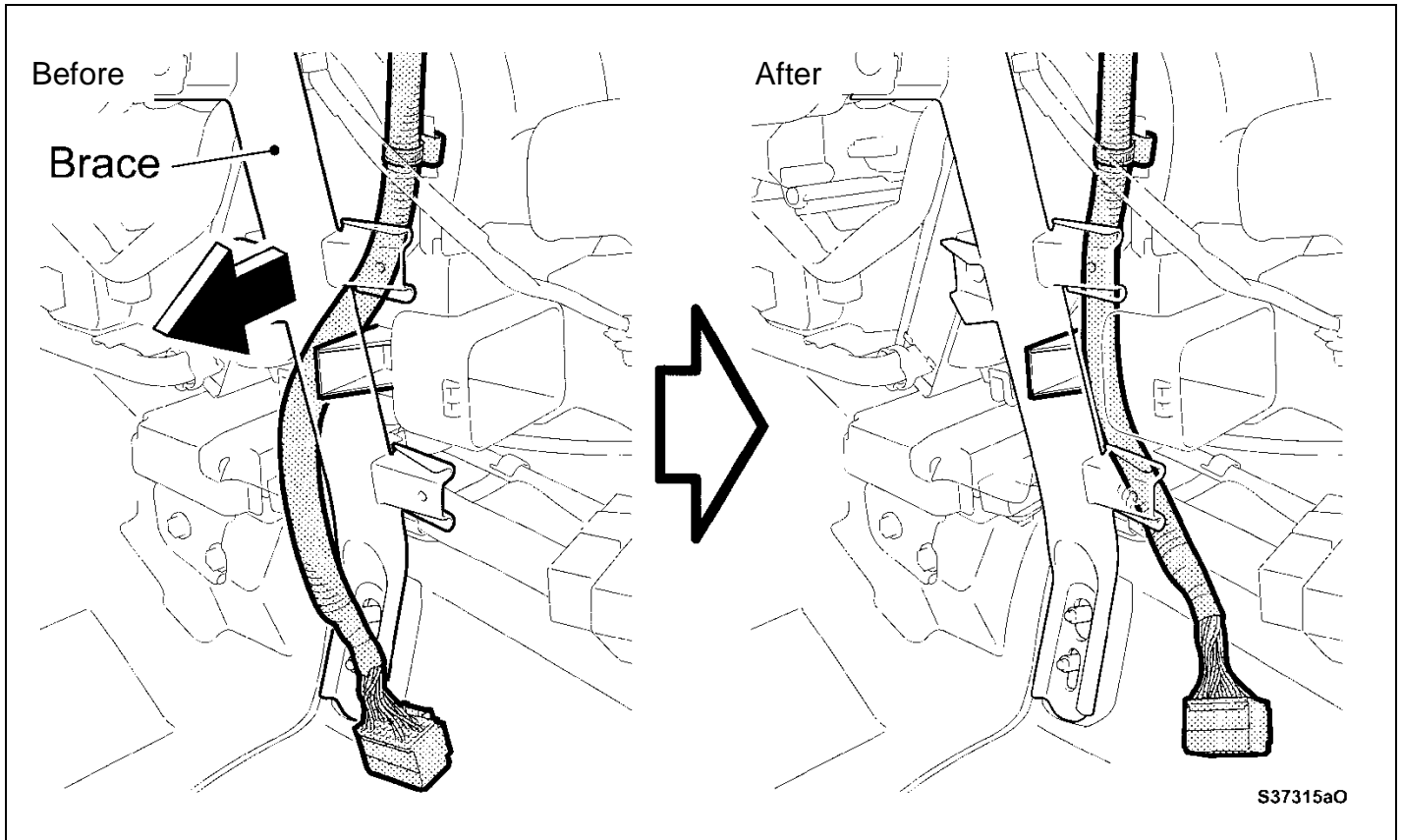

d) Reinstall the dash brace.

- 1) Reinstall the 4 nuts.  
**Torque: 21 N\*m (214 kgf\*cm, 15 ft.\* lb)**
- 2) Reinstall the 2 bolts and tighten.
- 3) Remove the protective tape.

**NOTE: If the sub-harness has already been installed proceed to Step 14g.**

e) Route the 2 floor harnesses as shown.

**NOTE: The 2 floor harnesses should be routed so they are on top of the newly installed sub harness.**

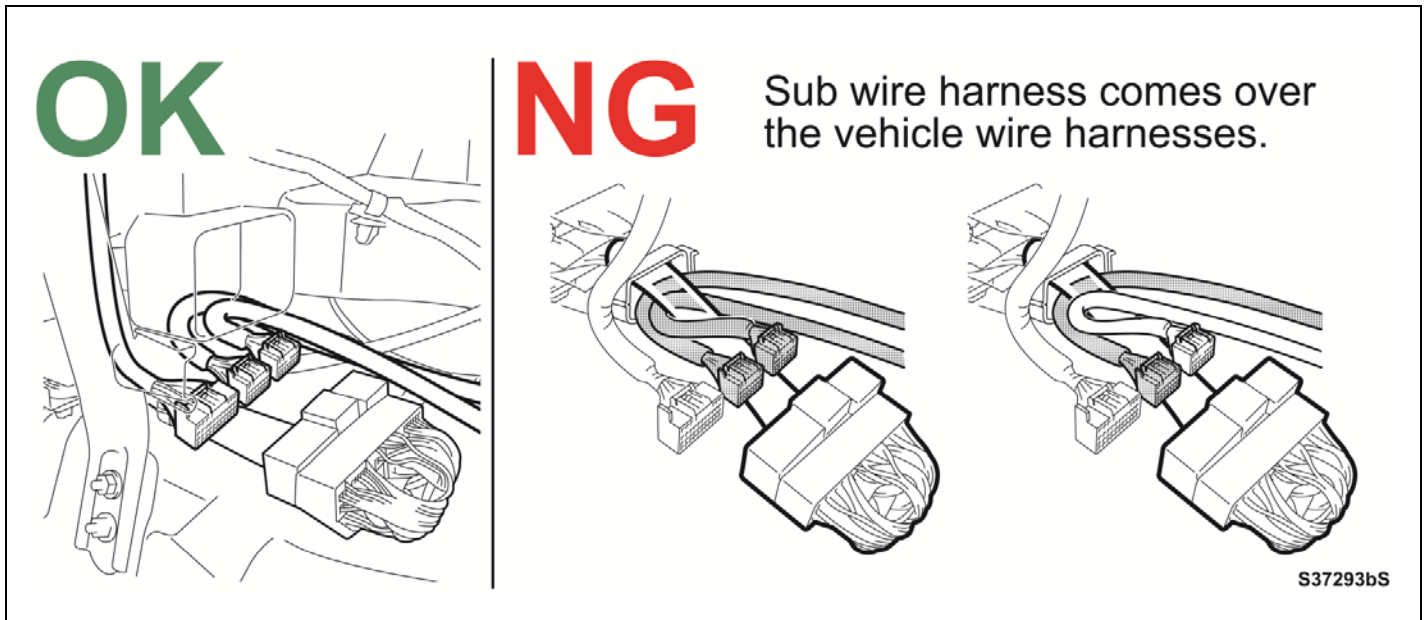

f) Using a tie wrap secure the excess length of the floor harness as shown.

**NOTE: Wrap the tie wrap around the protective tubing of the floor harnesses.  
Route the floor harnesses as shown to prevent abnormal vibrations and noises.**

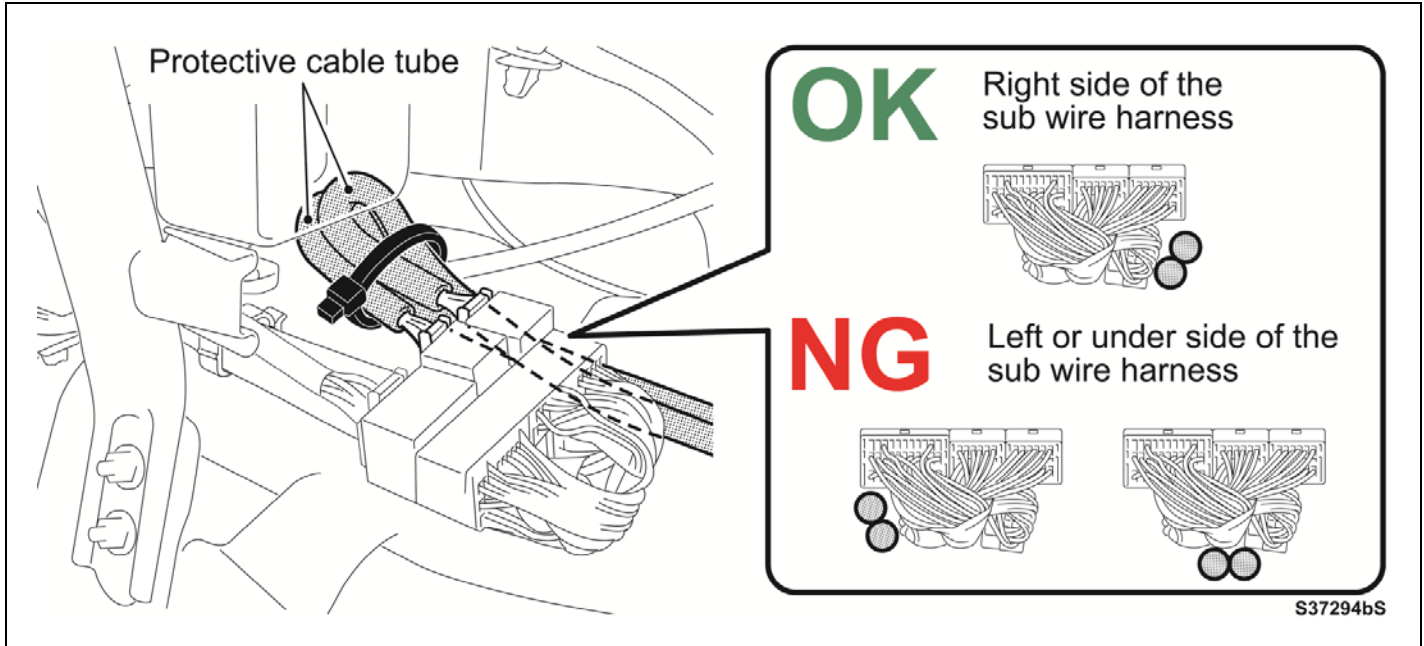

## 14. INSTALL WATER GUARD SHEET

- a) Remove the backing paper to expose the adhesive strip on the water guard sheet.
- b) Position the water guard sheet with the adhesive strip towards the rear of the vehicle.
- c) Place the wire harness connector in the center of the water guard sheet.

**NOTE: Ensure that the 2 floor harnesses are positioned on the right side of the sub harness.**

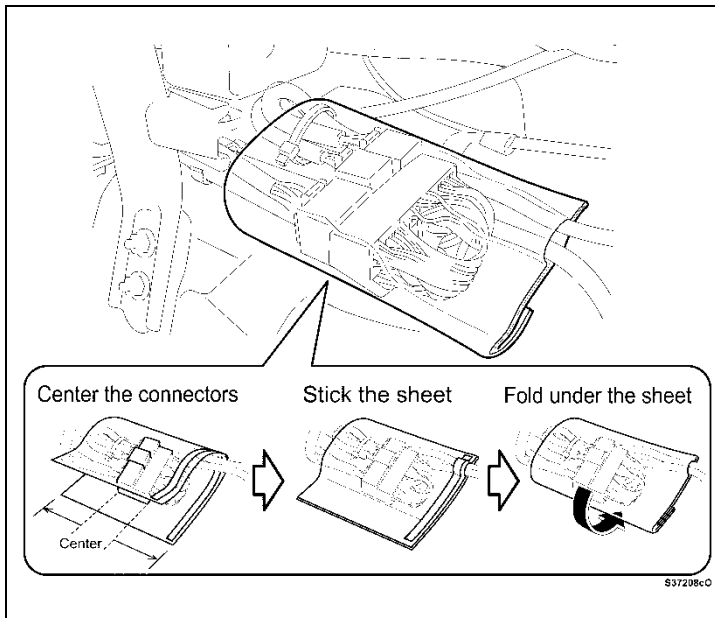

- d) Wrap the water guard sheet around the sub harness connector and stick the adhesive surface together as shown.
- e) Fold any excess portion of the sheet underneath the sub harness.

**NOTE: The water guard sheet is necessary to protect the sub harness connectors in case of water condensation from the HVAC unit.**

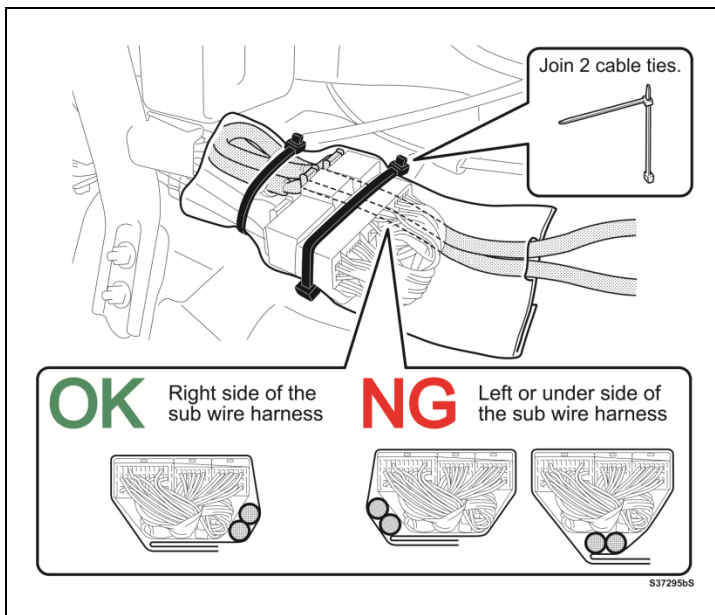

- f) Install tie wraps as shown.
  - 1) Place a tie wrap at the front of the water guard sheet.
  - 2) Join 2 tie wraps and place it at the center of the water guard sheet.

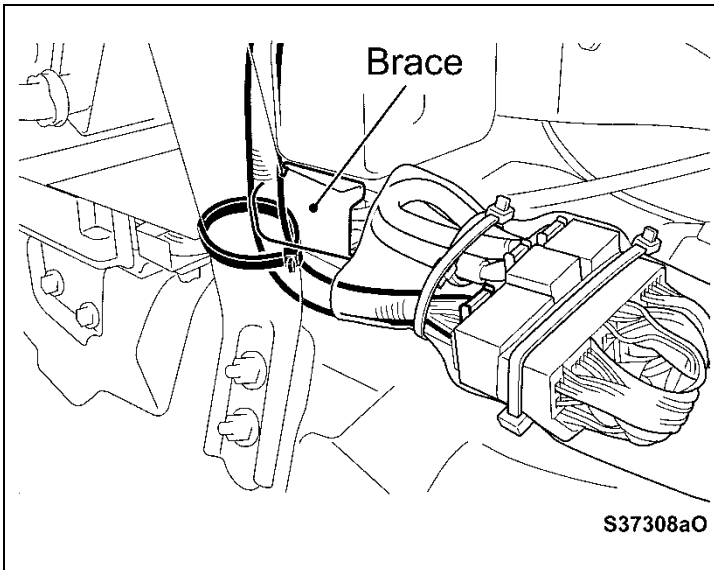

g) Using a tie wrap, fasten the dash harness to the bottom of the dash brace.

**NOTE: Position the tie wrap as shown to prevent it from interfering with the floor bracket.**

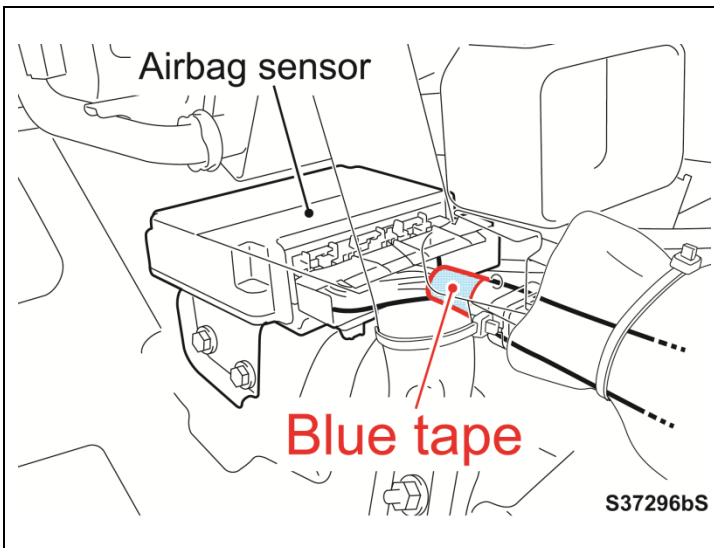

h) Reconfirm that the dash and 2 floor harness connectors are fully engaged into the airbag ECU.

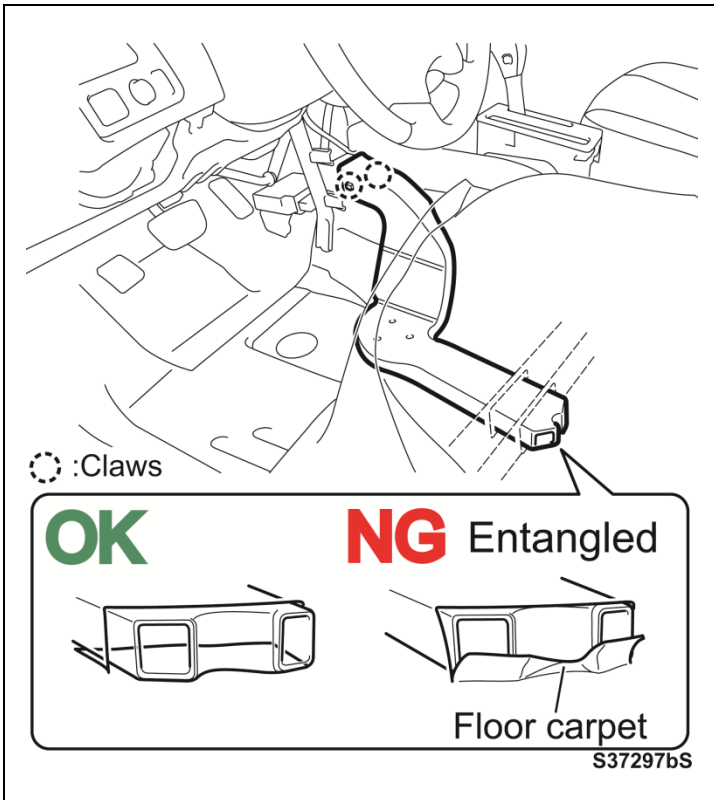

## 15. REASSEMBLE THE VEHICLE

a) Reinstall the left rear air duct.

- 1) Insert the air duct into the opening under the left front seat.

**NOTE: To prevent the duct from being blocked by the carpet, pull the duct from the rear of the seat. Ensure that the duct outlet is not blocked by the carpet.**

- 2) Connect the air duct to the HVAC unit.

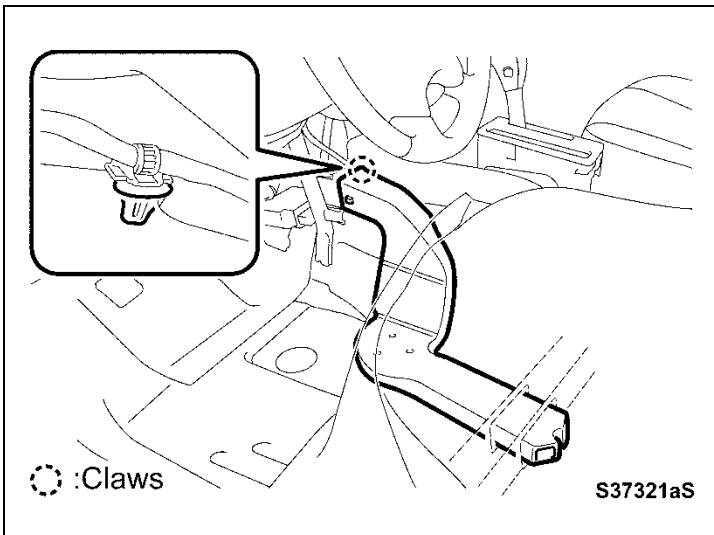

b) Reinstall the wire harness clamp.

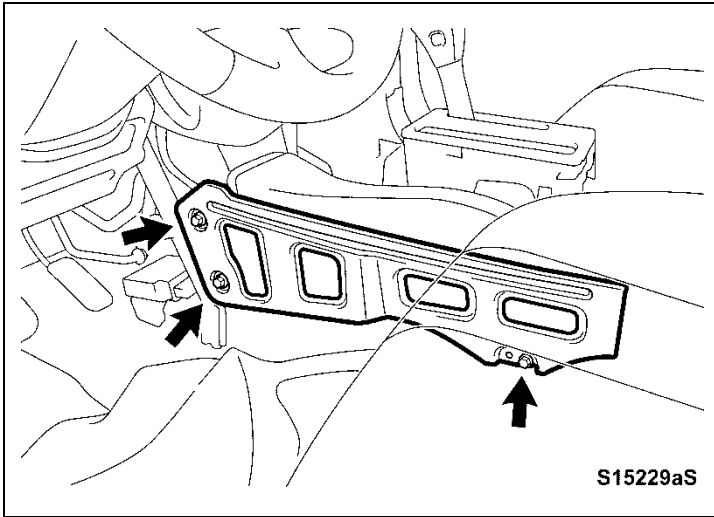

c) Reinstall the floor carpet bracket.

- 1) Reinstall the 3 bolts.

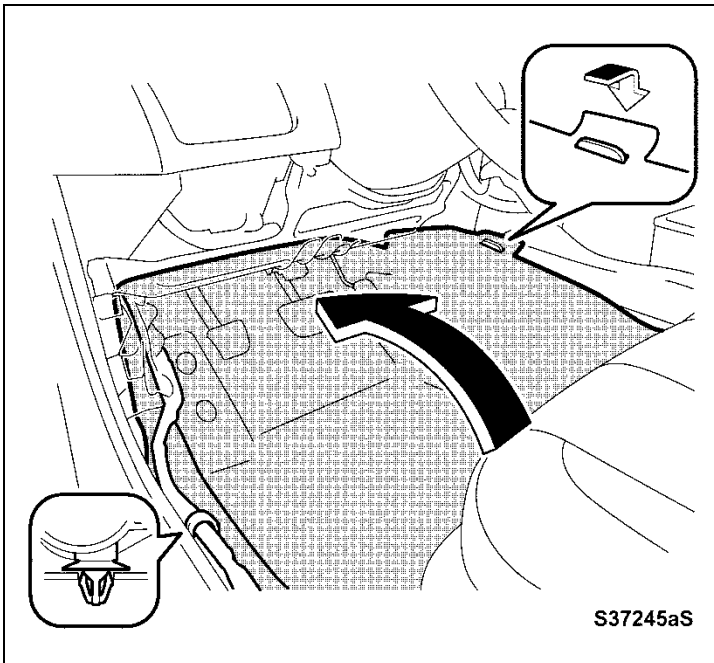

d) Return the left front carpet to its original position and secure it to the bracket.



**Ensure that the carpet is returned to its original position, and secured so that it does not interfere with pedal operation**

e) Reengage the claw for the floor harness clamp.

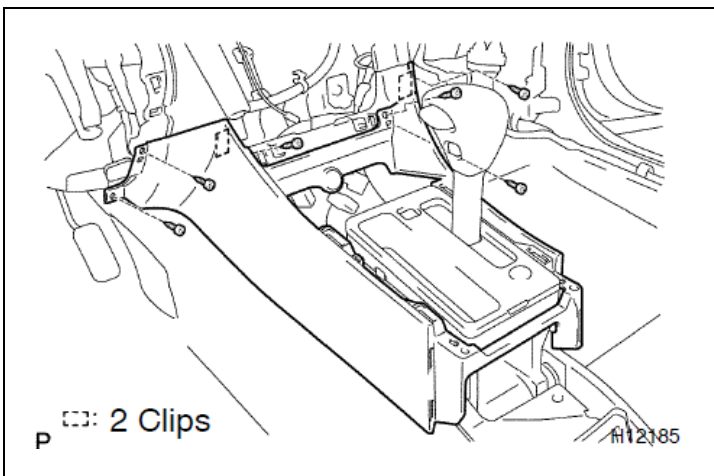

f) Reinstall the front console box.

- 1) Reinstall the 6 screws

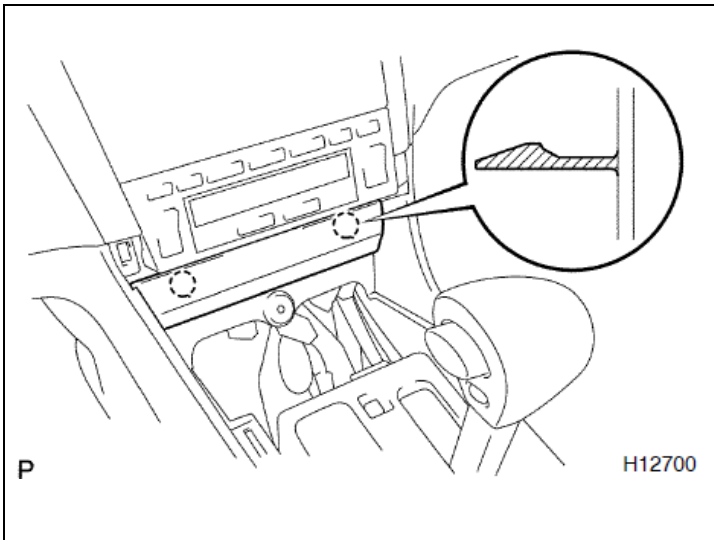

- g) Reinstall the console hole box cover.
- h) Reinstall the rear console box assembly.
  - 1) Reconnect the connector.
  - 2) Reinstall the 3 bolts.
  - 3) Reinstall the 2 screws.
  - 4) Reinstall the console box plate.

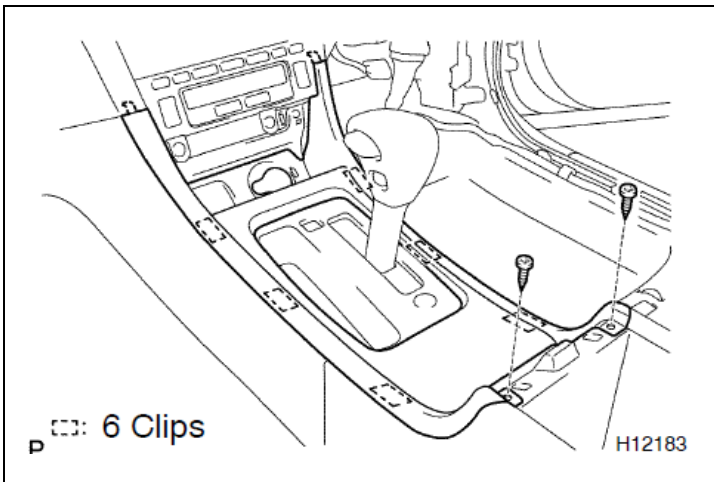

- i) Reinstall the cup holder.
- j) Reinstall the console upper panel sub-assembly.
  - 1) Reinstall the 2 screws.

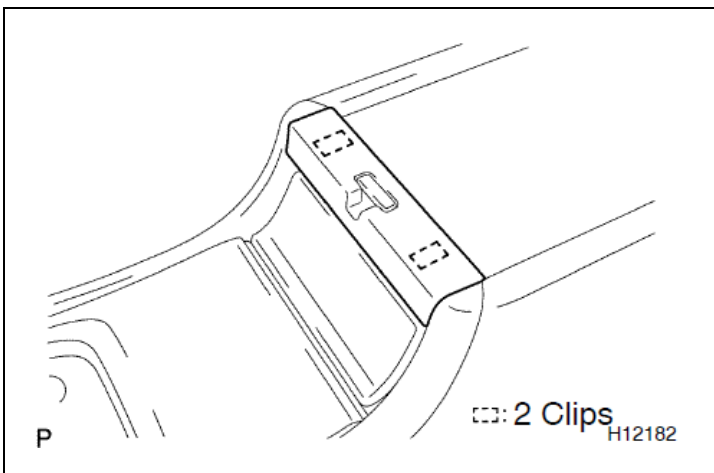

- k) Reinstall the front ash tray.
- l) Reinstall the console upper rear panel sub-assembly.

- m) Reinstall the left front footrest.
- n) Reinstall the left cowl trim sub-assembly.



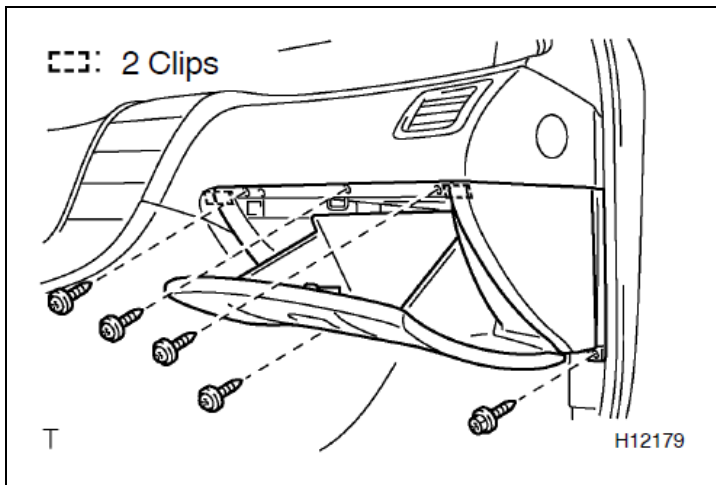

- o) Reinstall the glove box
  - 1) Reinstall the 5 screws.
- p) Reinstall the instrument panel under cover sub-assembly No. 2.

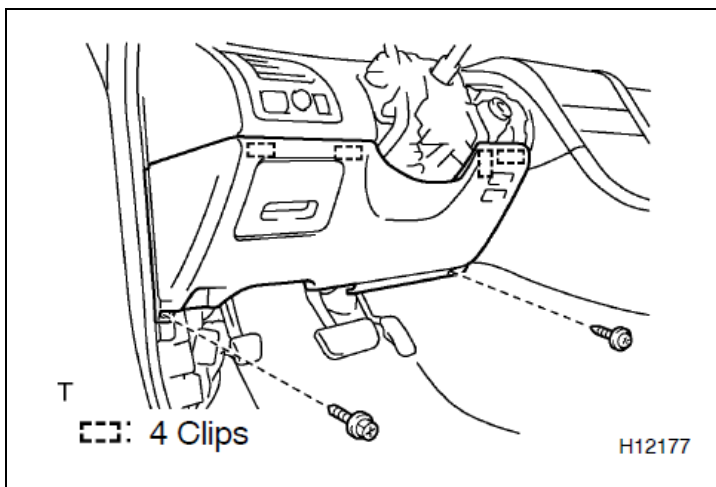

- q) Reinstall the No. 1 lower panel.
- r) Reinstall the hood lock release using the 2 screws.

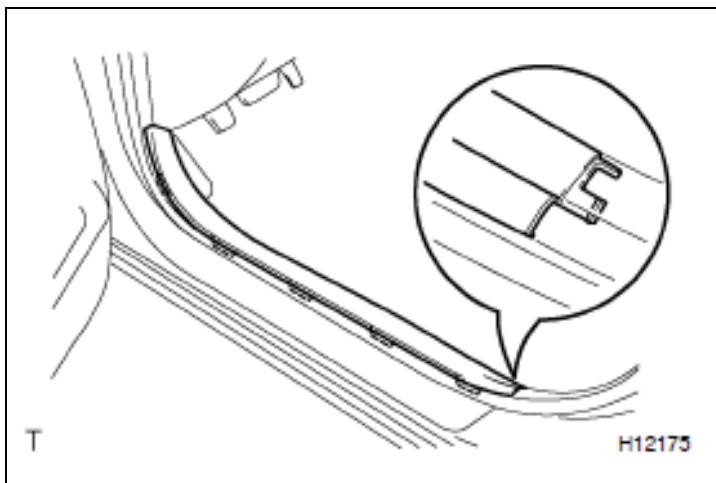

- s) Reinstall the left and right door scuff plate.

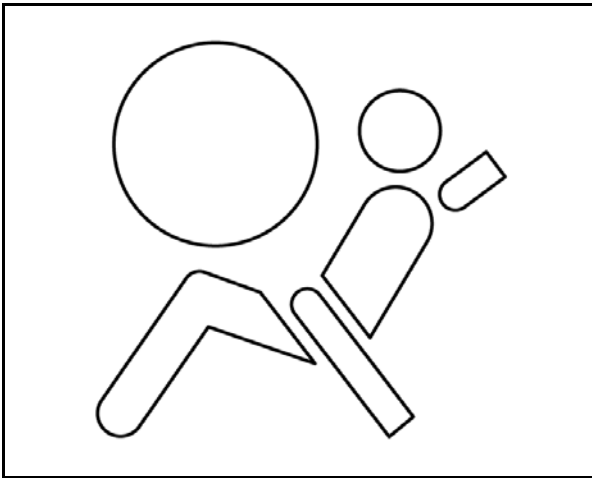

**16. RECONNECT THE NEGATIVE BATTERY TERMINAL**

**17. CHECK THE AIRBAG WARNING INDICATOR**

- a) Check that the warning indicator illuminates when the ignition is switched on.
- b) Confirm that the warning light will go off after about 6 seconds have elapsed after IG on.



- After the 6 second illumination of the warning indicator, if the indicator goes off then back on or remains on, check for DTCs and confirm the sub harness was installed correctly.
- Consult with the customer to determine if they would like to diagnose/repair any remaining concerns.

**18. RESTORE VEHICLE SETTINGS**

- a) Restore any memory settings and initialize any system needed (i.e. power windows, moonroof, etc.).
- b) Return the steering column and seats to their original positions.

**◀ VERIFY REPAIR QUALITY ▶**

- Confirm any DTCs prior to beginning this repair
- Read all precautions as outlined on TIS before servicing the SRS system
- Confirm ALL harness connectors are connected securely
- Confirm the water guard sheet is secured and positioned correctly
- Confirm there are no DTCs when the repair is complete

If you have any questions regarding this update, please contact your area representative.

**VI. APPENDIX**

**A. CAMPAIGN DESIGNATION DECODER**

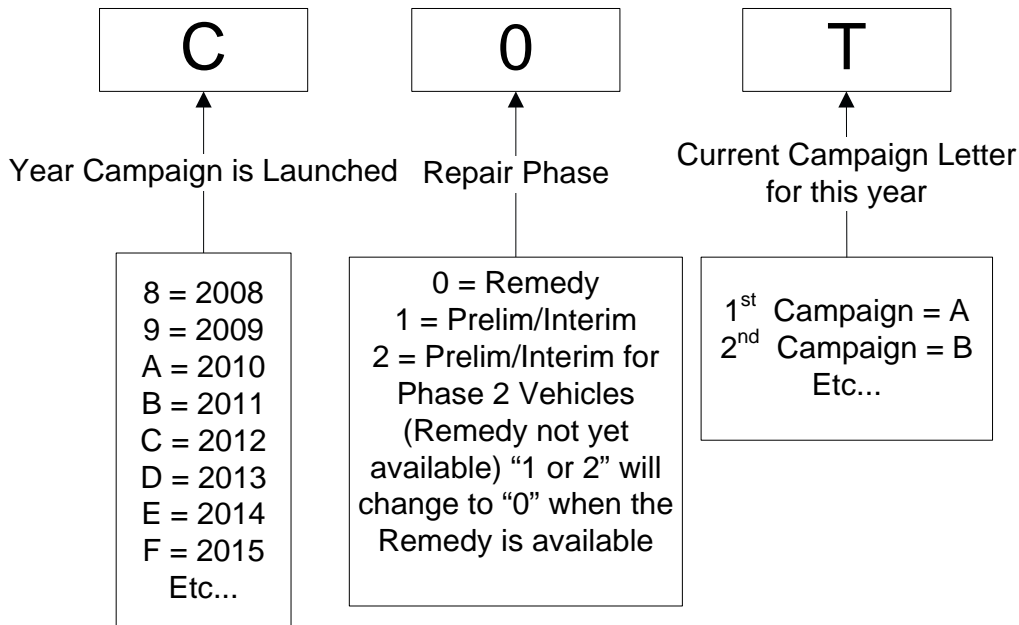

**B. CAMPAIGN PARTS DISPOSAL**

As required by Federal Regulations, please make sure all campaign parts (original parts) removed from the vehicle are disposed of in a manner in which they will not be reused, ***unless requested for parts recovery return.***