

TECHNICAL INSTRUCTIONS
FOR
SAFETY RECALL ESG
(Supersedes the E0G campaign)
SRS ECU & SUB HARNESS (FILTER) INSTALLATION
2003 – 2004 MODEL YEAR AVALON
COLUMN MOUNTED SHIFT LEVER
(FRONT BENCH SEAT)

The repair quality of covered vehicles is extremely important to Toyota. All dealership technicians performing this procedure are required to successfully complete the most current version of the E-Learning course “Safety Recall and Service Campaign Essentials” To ensure that all vehicles have the repair performed correctly; technicians are required to currently hold at least one of the following certification levels to perform this operation:

- Toyota Expert Electrical
- Master
- Master Diagnostic Technicians

It is the dealership’s responsibility to select technicians with the above certification level or greater to perform this repair. Carefully review your resources, the technician skill level, and ability before assigning technicians to this repair. It is important to consider technician days off and vacation schedules to ensure there are properly trained technicians available to perform this repair at all times.

I. OPERATION FLOW CHART

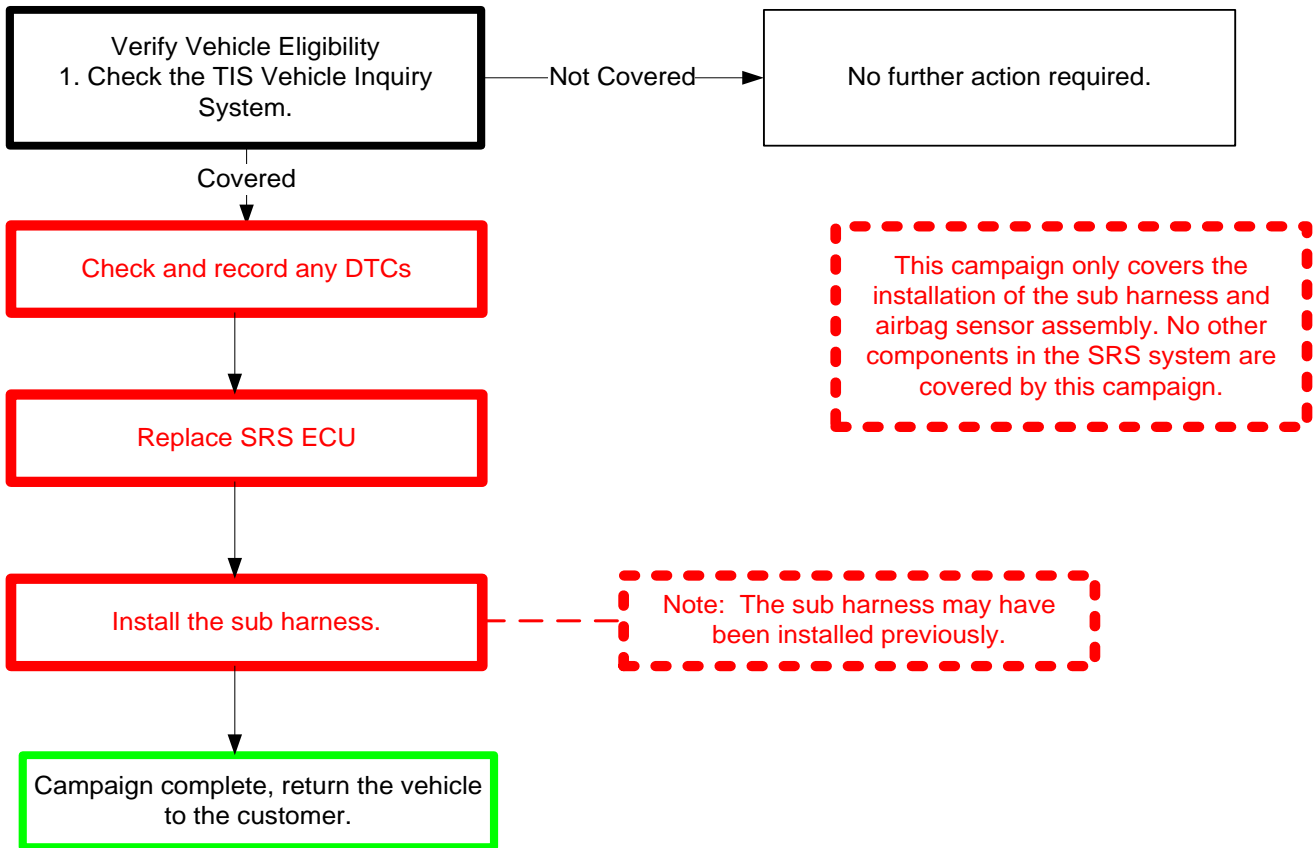

II. PREPARATION

A. PARTS

Part Number	Part Description	Quantity												
04004-22141	Airbag Harness Kit*	1												
04004-26207 or 04005-02807	Airbag Sensor Assembly (SRS ECU)	1												
87201-07130	HVAC Duct*	1												
<p>* Do Not Order if Sub Harness was previously installed. Check vehicle Service History to confirm. The kit above includes the following parts.</p> <table border="1" style="margin-left: auto; margin-right: auto;"> <tbody> <tr> <td style="text-align: center;">-</td> <td style="text-align: center;">Airbag sub harness</td> <td style="text-align: center;">1</td> </tr> <tr> <td style="text-align: center;">-</td> <td style="text-align: center;">Water guard tape (large)</td> <td style="text-align: center;">1</td> </tr> <tr> <td style="text-align: center;">-</td> <td style="text-align: center;">Water guard tape (small)</td> <td style="text-align: center;">2</td> </tr> <tr> <td style="text-align: center;">-</td> <td style="text-align: center;">Cable tie</td> <td style="text-align: center;">7*</td> </tr> </tbody> </table>			-	Airbag sub harness	1	-	Water guard tape (large)	1	-	Water guard tape (small)	2	-	Cable tie	7*
-	Airbag sub harness	1												
-	Water guard tape (large)	1												
-	Water guard tape (small)	2												
-	Cable tie	7*												
<p>*2 extra ties are provided as a supplement.</p>														

B. TOOLS & EQUIPMENT

- Standard hand tools
- Torque wrench
- Techstream
- Tape measure
- Vinyl tape

SST – This is an essential special service tool that the dealership should have.

Part Number	Part Name	Quantity
00002-06000-01	Plastic pry Tool Set	1

III. BACKGROUND

The Electronic Control Module (ECM) for the Supplemental Restraint System (SRS) in these vehicles could have been manufactured with integrated circuits that are susceptible to internal short circuiting when exposed to certain electrical noise from various vehicle electrical components. If internal short circuiting occurs, the front airbag(s) and/or seat belt pre-tensioners could inadvertently deploy. An airbag that deploys inadvertently can, under some circumstances, increase the risk of minor injury and the possibility of a crash.

NOTE:

- Check the TIS Vehicle Inquiry System to confirm the VIN is involved in this Safety Recall, and that the campaign has not already been completed prior to dealer shipment or by another dealer.
- **TMS warranty will not reimburse dealers for repairs conducted on vehicles that are not affected or were completed by another dealer.**

IV. COMPONENTS

MODELS WITH COLUMN-MOUNTED SHIFT LEVER

For installation of sub wire harness

Components to be installed:

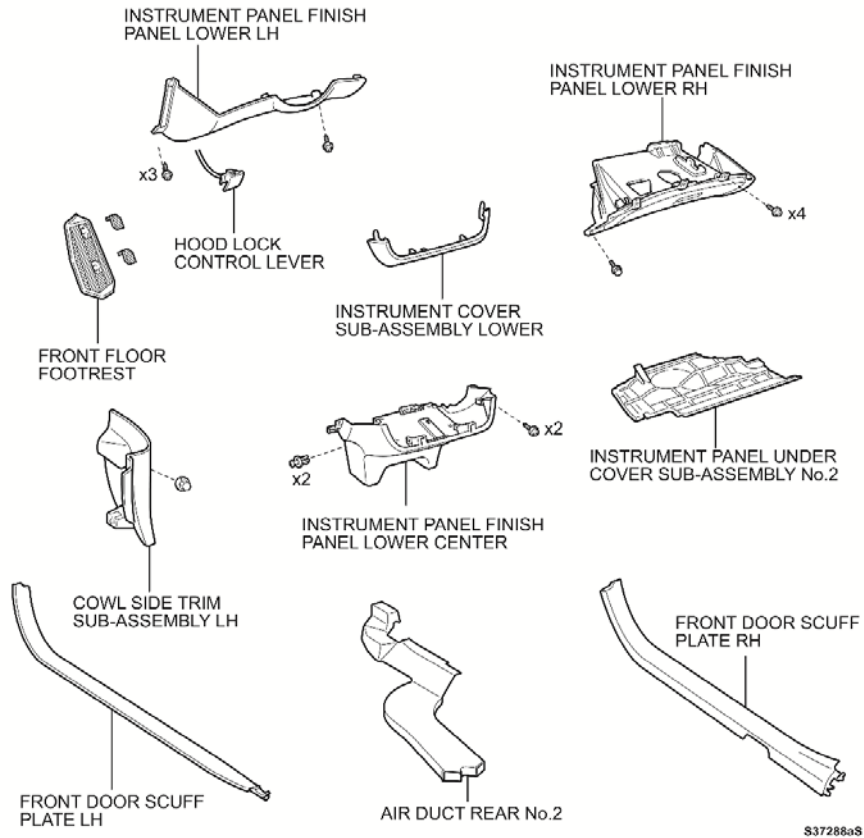
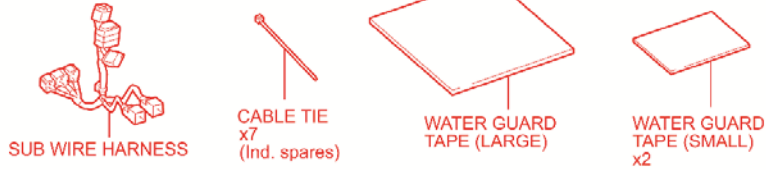

For replacement of airbag sensor assembly

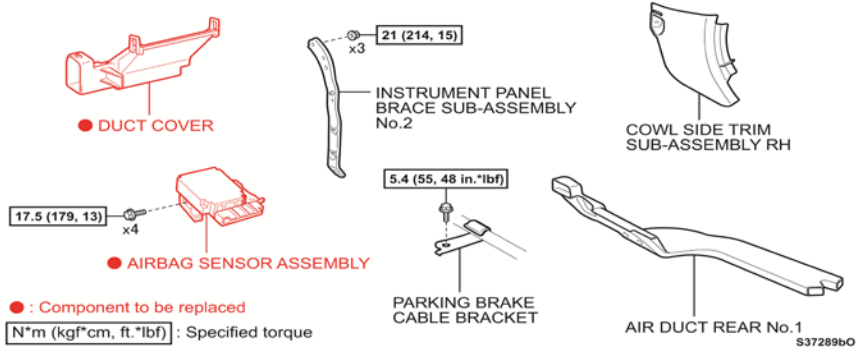

NOTE: The vehicle could have one of the following scenarios:

Current Status	Repair
No prior repair and EOG campaign shows not completed	Replace SRS ECU and install Airbag Harness Kit
Airbag Harness Kit previously installed under EOG	Replace SRS ECU

V. WORK PROCEDURE

1. PREFORM A HEALTH CHECK



This campaign only covers the installation of the sub harness and Airbag Sensor Assembly (SRS ECU). No other components in the SRS system are covered by this campaign.

- a) Using Techstream, perform a health check to confirm if there are any DTCs present in the system (**Both current or history**).

NOTES:

- Ensure that the Techstream software is 9.2 or higher.
- On the “connect to vehicle” screen, enter the VIN number to ensure that the vehicle information is uploaded to TIS.
- **A Health check must be performed on every vehicle. Record any DTCs as they are used to confirm the vehicles final state after repair and aid in any additional dicussions needed with the customer.**

2. SET THE PARKING BRAKE

3. RECORD AUDIO, SEAT, STEERING COLUMN AND CLIMATE CONTROL SETTINGS

4. MOVE THE DRIVER AND PASSENGER SEAT TO THE REAR MOST POSITION

5. ADJUST THE STEERING COLUMN TO THE UPPER MOST POSTION

6. DISCONNECT THE NEGATIVE BATTERY TERMINAL



- Wait at least 90 seconds after disconnecting the cable from the negative battery terminal to prevent airbag and seat belt pre-tensioner deployment.
- Follow all precautions as outlined on TIS before servicing the SRS system.

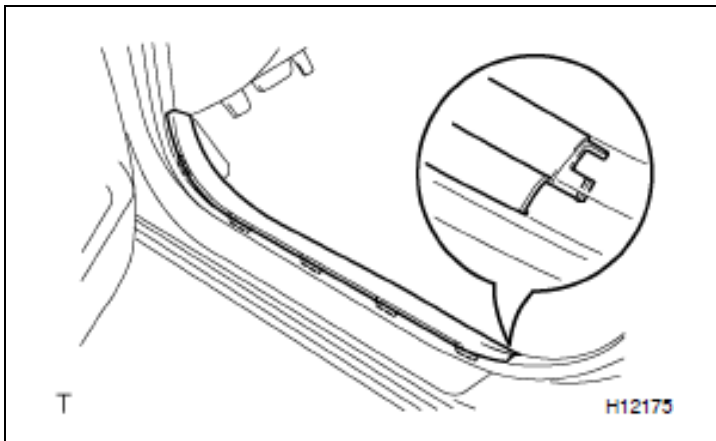

7. REMOVE THE CENTER FINISH PANEL

- a) Remove the left and right front door scuff plate.
- b) Remove the instrument panel under cover sub-assembly No.2.

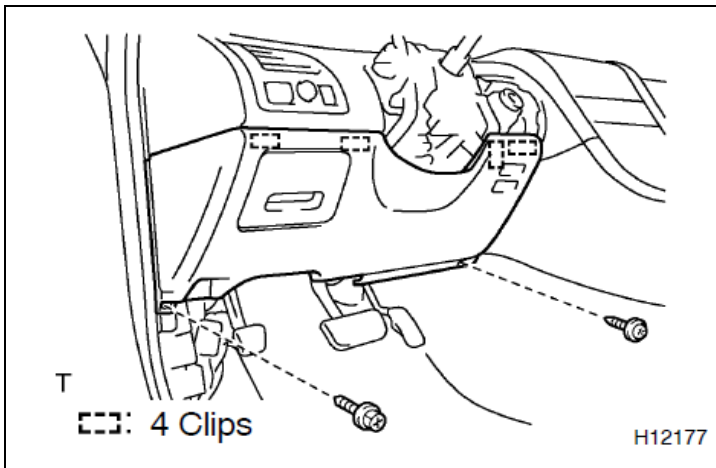

- c) Remove the No. 1 lower panel.
- 1) Remove the 2 screws and hood lock release lever.
- 2) Using a plastic pry tool, remove the No. 1 lower panel.
- d) Remove the cowl side trim sub-assembly LH.
- e) Remove the left front floor footrest.

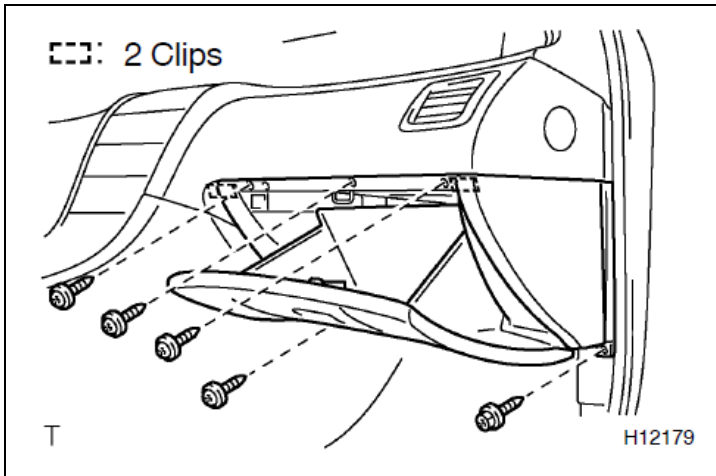

f) Remove the glove box.

- 1) Remove the 5 screws.
- 2) Using a plastic pry tool, remove the lower panel.

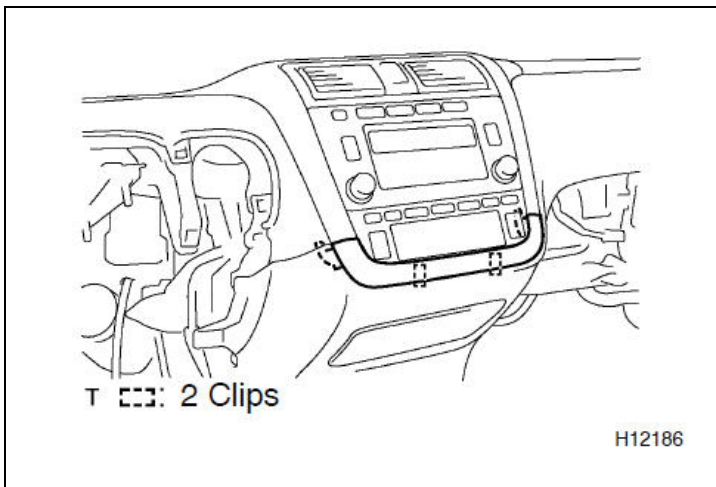

g) Remove the lower cover.

- 1) Using a plastic pry tool remove the lower cover.

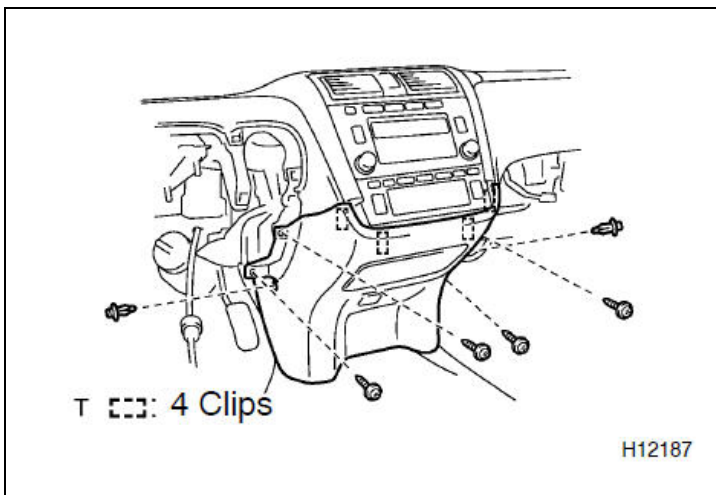

h) Remove finish panel.

- 1) Remove the following.
 - 4 screws
 - 2 clips

i) Disconnect the connector for the auxiliary power outlet.

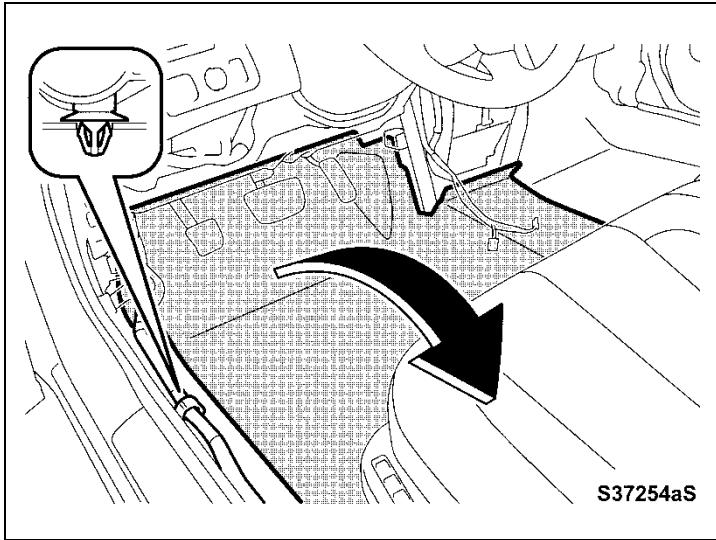

8. REMOVE THE AIR REAR DUCT No. 2

- a) Disengage the claw for the floor wire harness clamp.
- b) Unhook the carpet from the bracket.
- c) Fold the carpet back half way.

NOTE: Wear gloves to protect your hand from sharp edges.

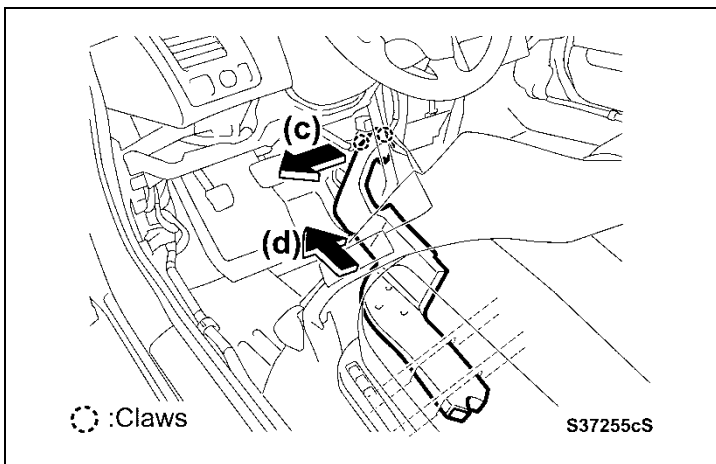

- d) Move the air duct to the left to disengage the 2 claws.
- e) Pull the air duct towards the front and remove it from the vehicle.

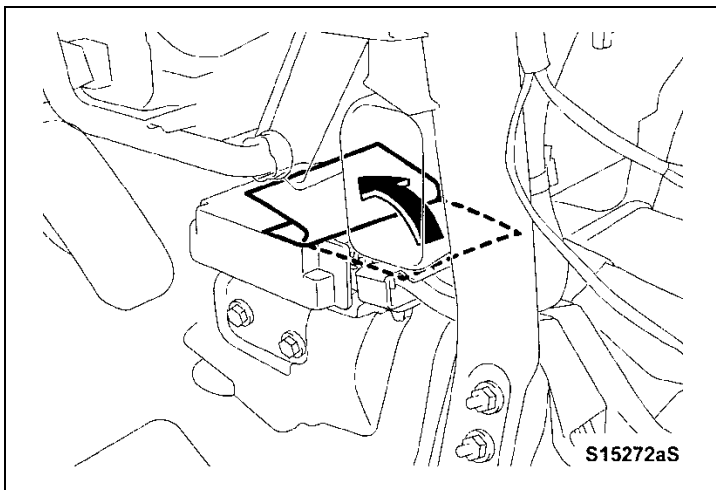

9. DISCONNECT THE HARNESS'S FROM THE AIRBAG ECU

- a) Fold back the plastic sheet that covers the connectors.



DO NOT remove the plastic sheet from the airbag ECU

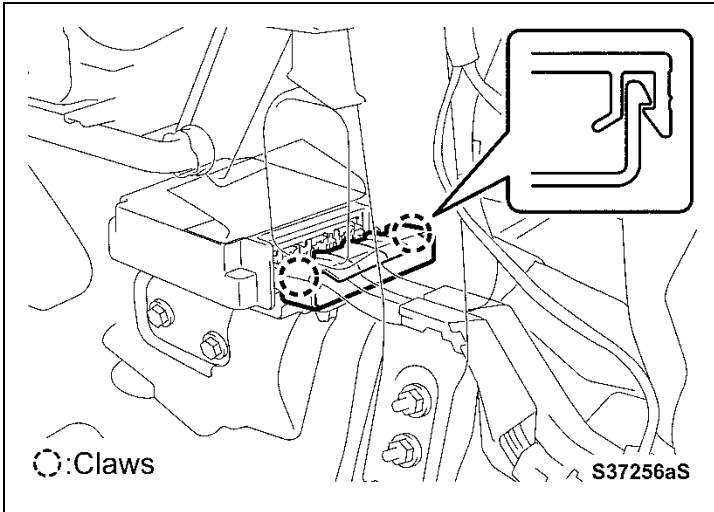

b) Disengage the 2 claws for the wire harness bracket.

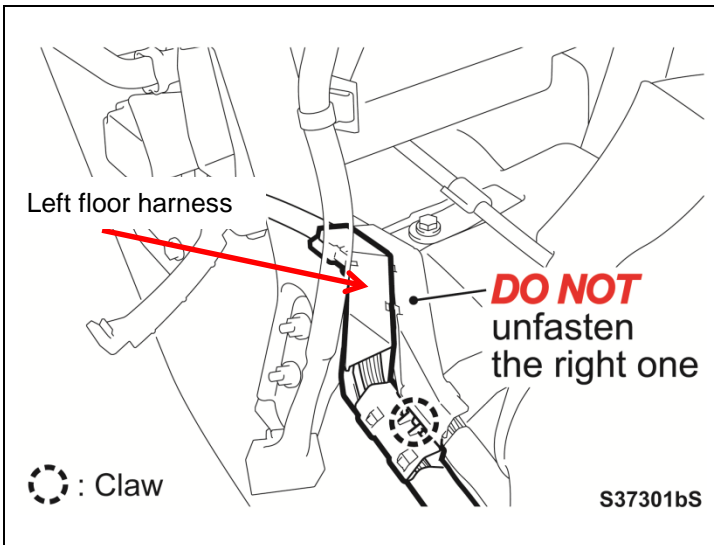

c) Disengage the claw for the left floor wire harness clamp protector.

NOTE: Do not unfasten the right side protector wire harness clamp.

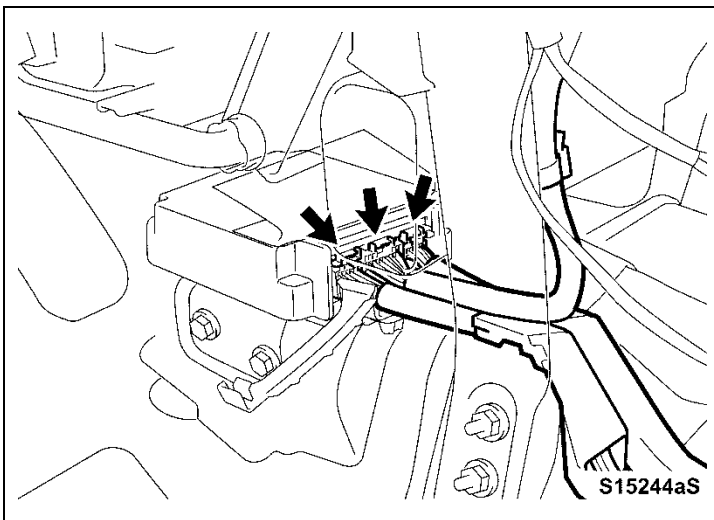

d) Disconnect the following from the airbag ECU:

- Left Floor Harness
- Dash Harness
- Right Floor Harness

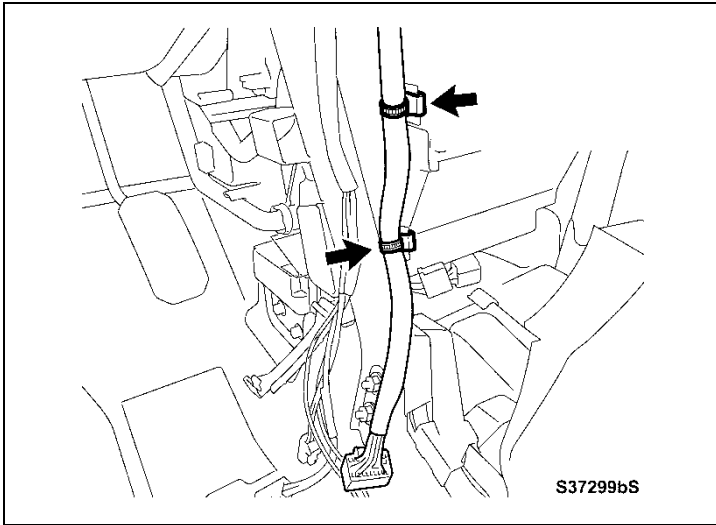

e) Disengage the 2 dash harness clamps as shown.

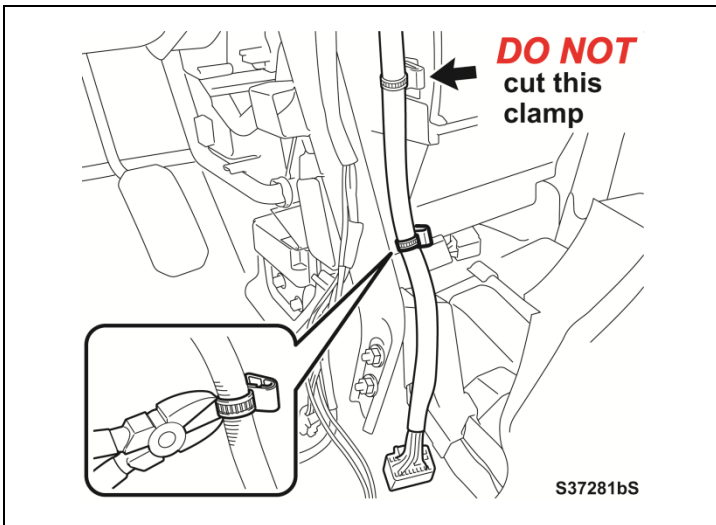

f) Cut and remove the clamp from the dash harness.

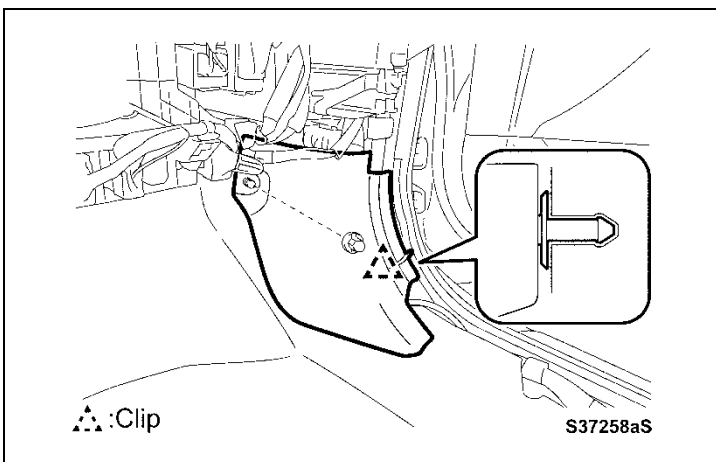

10. AIRBAG ECU REPLACEMENT

- a) Remove the right cowl side trim.
 - 1) Remove the nut.
 - 2) Remove disengage the clip.

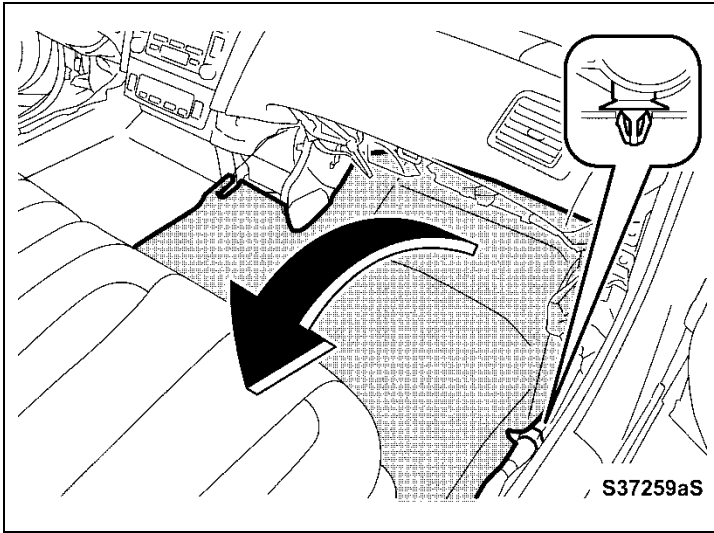

- b) Disengage the claw for the floor wire harness clamp.
- c) Fold the carpet back half way to access the airbag ECU.

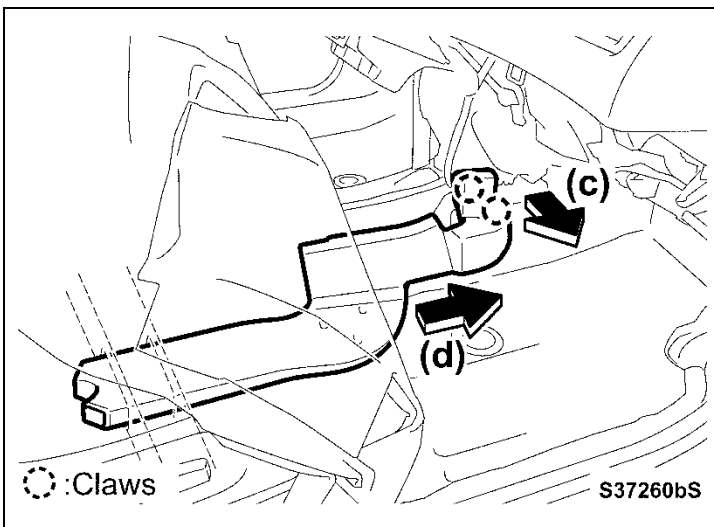

- d) Pull the air duct to the right to disengage the 2 claws.
- e) Move the air duct towards the front to remove it from the vehicle.

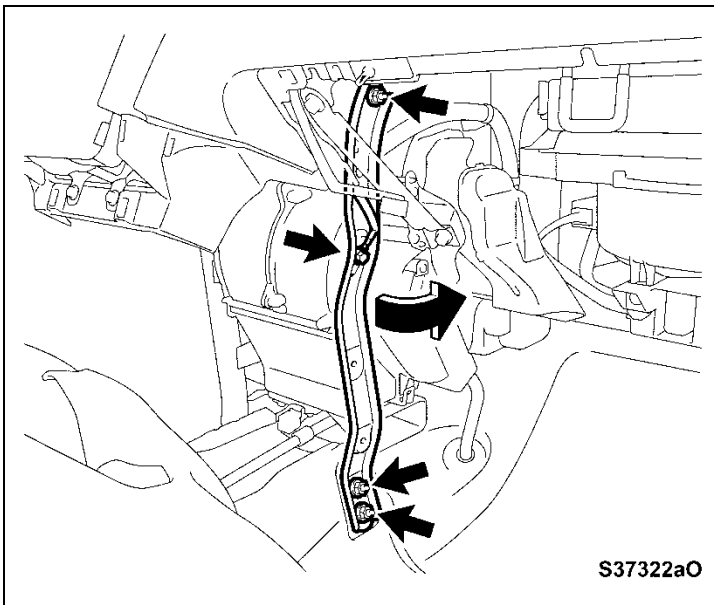

- f) Remove the following to remove right dash brace.
 - 1) Remove the 3 nuts.
 - 2) Remove the ground bolt.

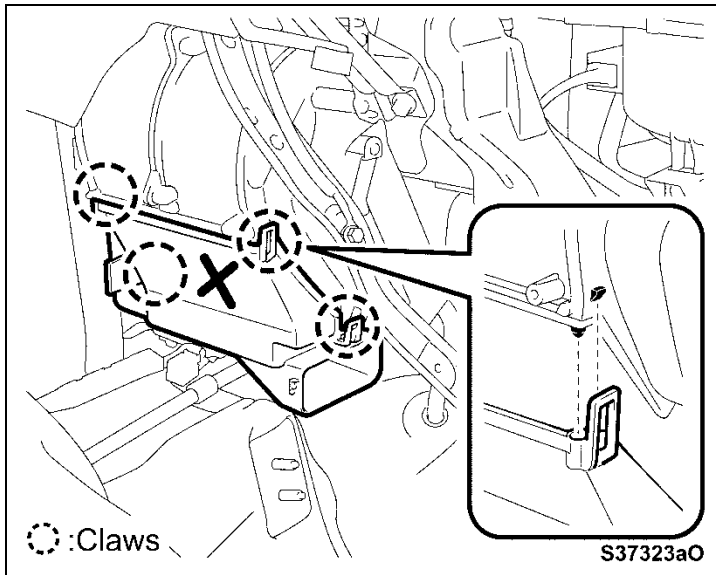

- g) Remove the duct cover.
- 1) Mark the duct cover so it is not reused.
 - 2) Disengage the 4 claws.
 - 3) Remove the cover.

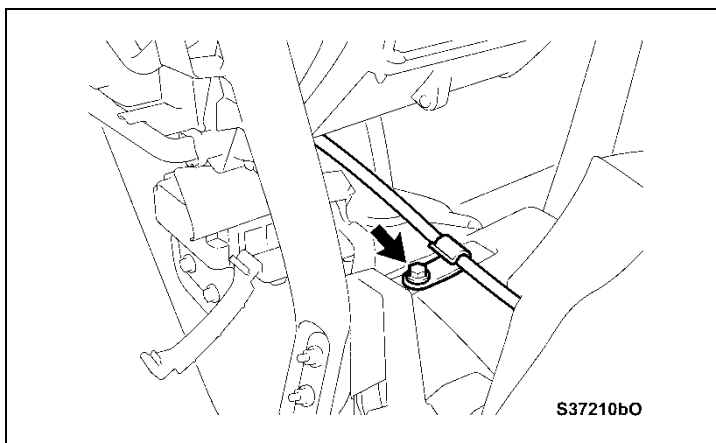

- h) Remove the parking brake cable bracket.
- i) Remove the bolt.

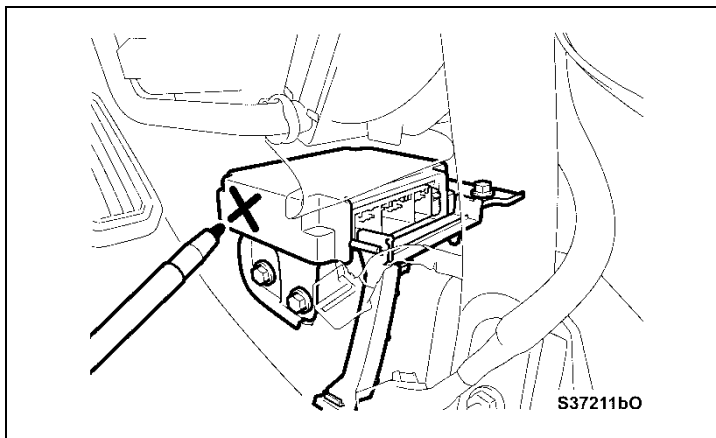

- j) Mark the old airbag ECU so it is not reused.

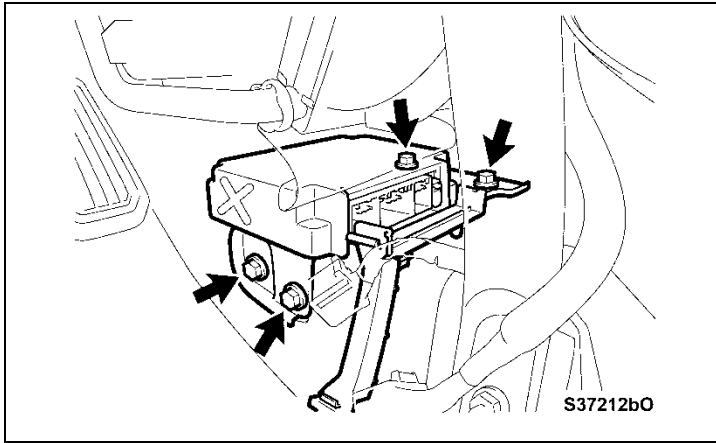

- k) Remove the 4 bolts.
- l) Remove the airbag ECU.

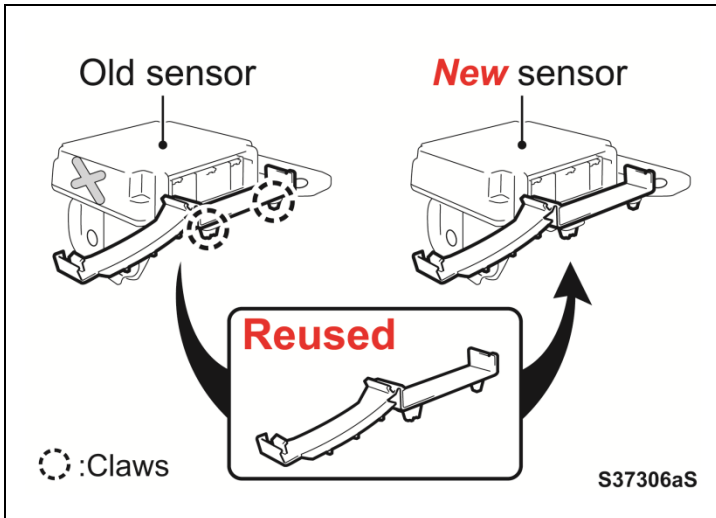

- m) Remove the wire harness bracket from the original ECU.
- n) Reinstall the wire harness bracket onto the new ECU.

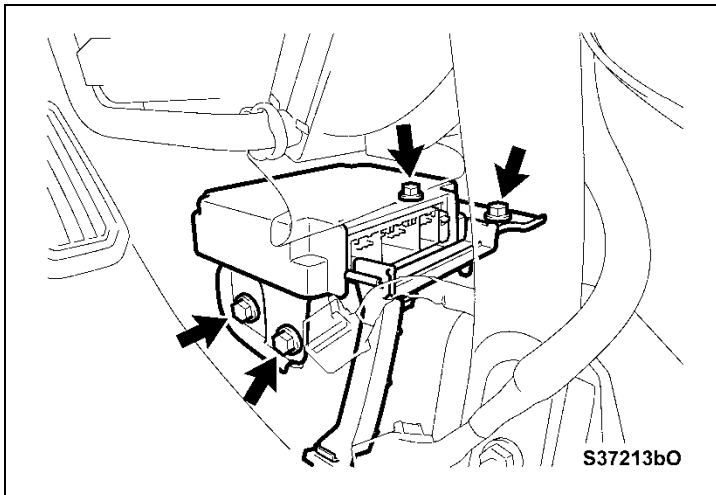

- o) Install the new airbag ECU.
- p) Install the 4 bolts.
Torque: 17.5 N•m (179 kgf•cm, 13 ft.•lb)

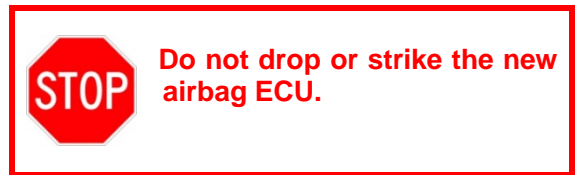

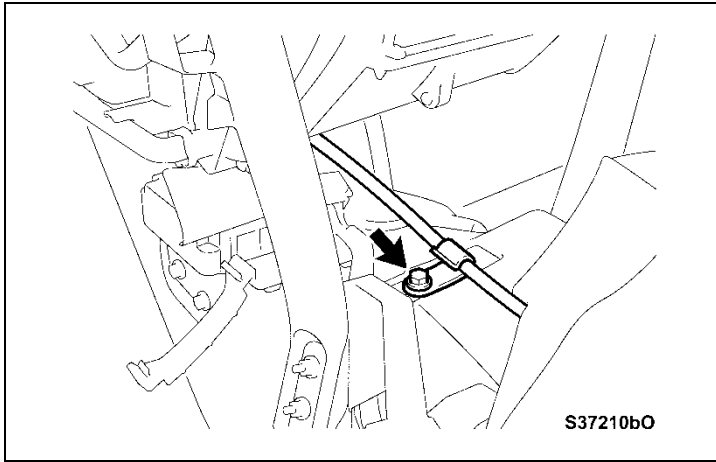

- q) Reinstall the parking brake cable bracket.
Torque: 5.4 N•m (55 kgf•cm, 48 in.•lb)

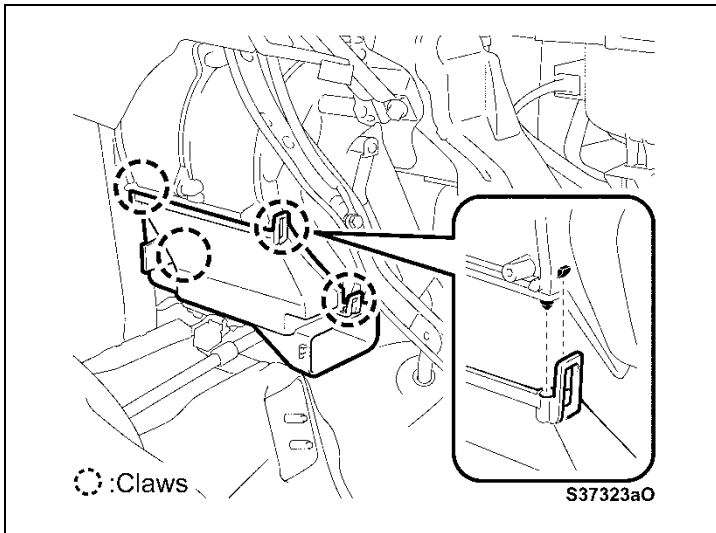

- r) Install the new duct cover.
1) Engage the 4 claws to attach the new duct cover to the HVAC unit.

NOTE: A new duct cover must be installed when the airbag ECU is replaced.

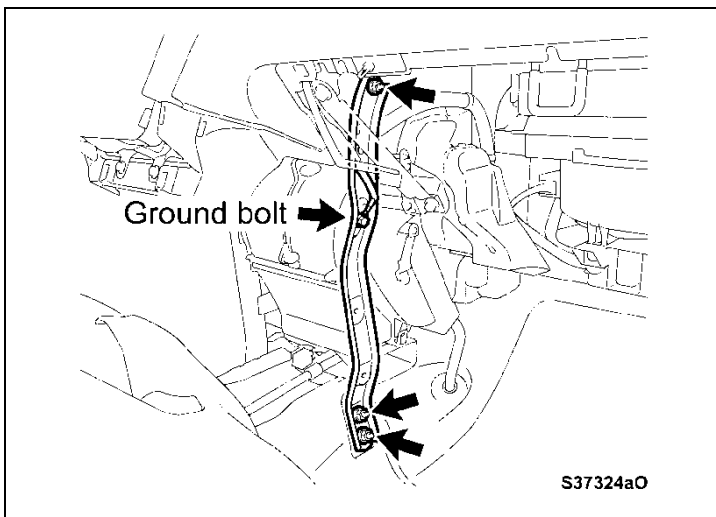

- s) Reinstall the right dash brace.
1) Reinstall the 3 nuts.
Torque: 20 N•m (214 kgf•cm, 15 ft.•lb)
- t) Reinstall the ground bolt.
Torque: 8.4 N•m (86 kgf•cm, 74 in.•lb)

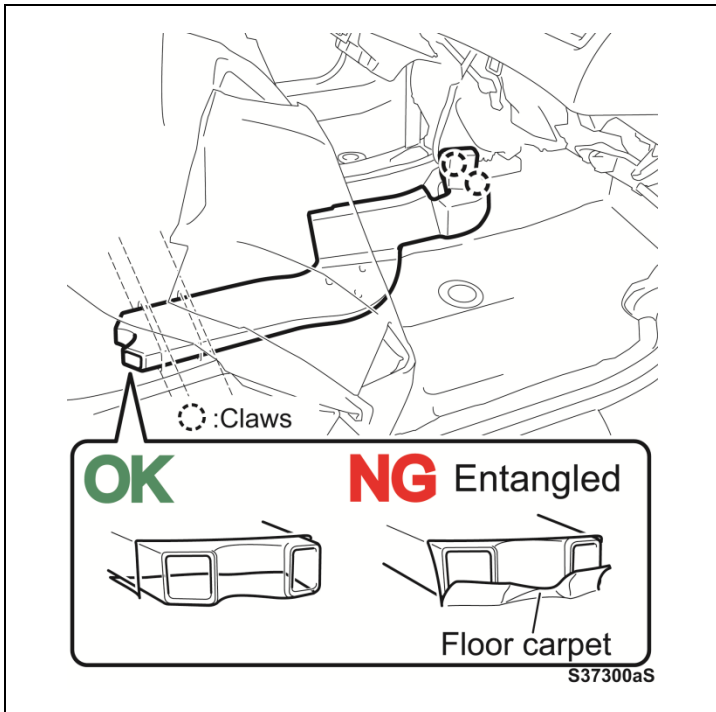

u) Reinstall the right air duct.

- 1) Insert the air duct into the opening under the right front seat.

NOTE: To prevent the duct from being blocked by the carpet, pull the duct from the rear of the seat. Ensure that the duct outlet is not blocked by the carpet.

v) Connect the air duct to the HVAC unit.

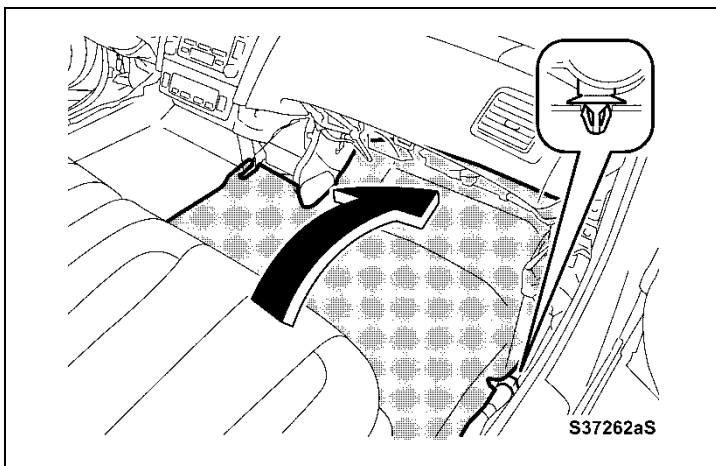

w) Return the right front carpet to its original position.

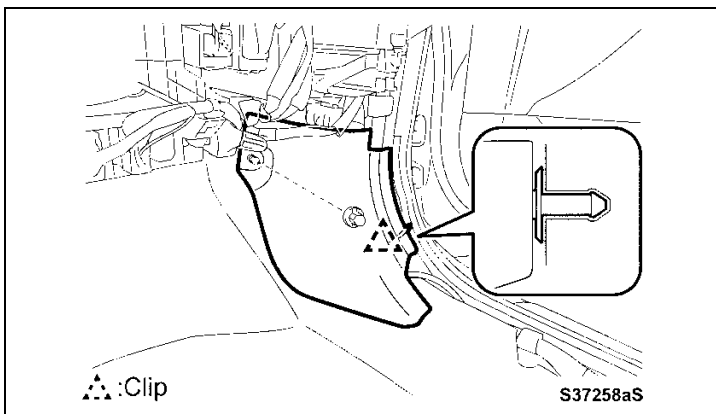

x) Reinstall the right cowl trim.

- 1) Engage the clip.
- 2) Reinstall the nut.



All vehicles require the installation of the sub harness. If the Sub Harness was previously installed, go to step 11a.

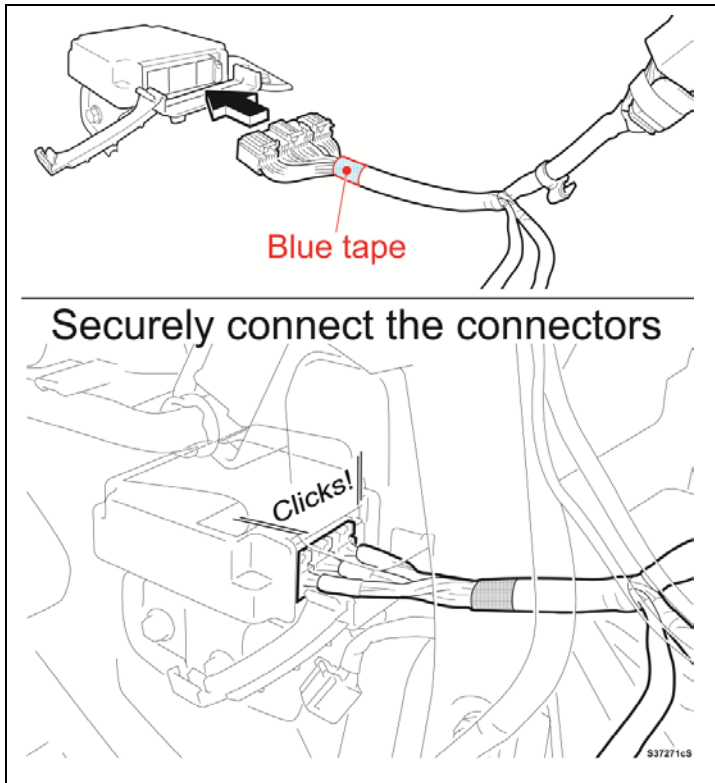

11. INSTALL SUB WIRE HARNESS

- a) Connect the 3 connectors of the sub wire harness to the airbag ECU.

NOTE: Ensure that the sub wire harnesses with the connectors near the blue tape are fully engaged into the ECU.

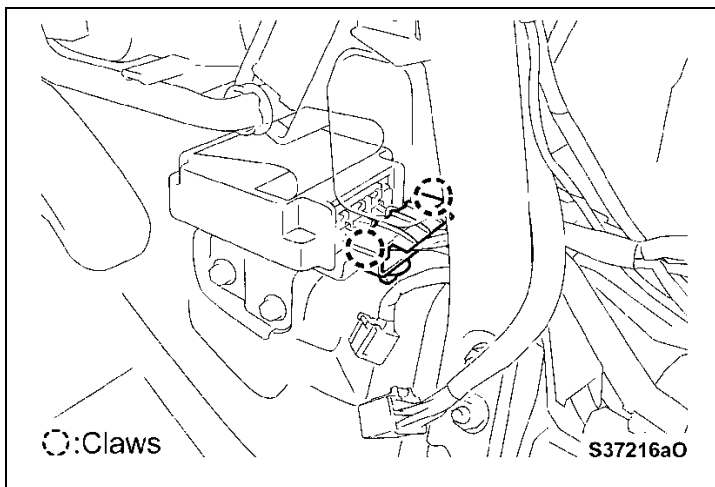

- b) Reengage the 2 claws for the wire harness bracket.

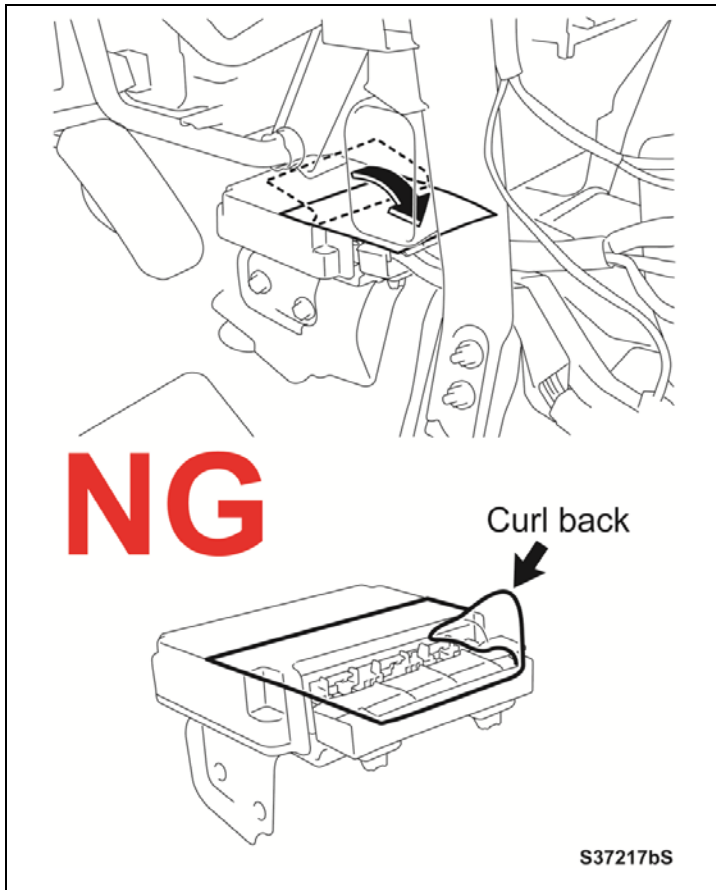

- c) Unfold the plastic sheet that is attached to the airbag ECU so that it covers the connectors.

NOTE: Ensure that the plastic sheet is positioned correctly and is not curled back on itself.
The plastic sheet protects the ECU and connectors in case of water condensation from the HVAC unit.

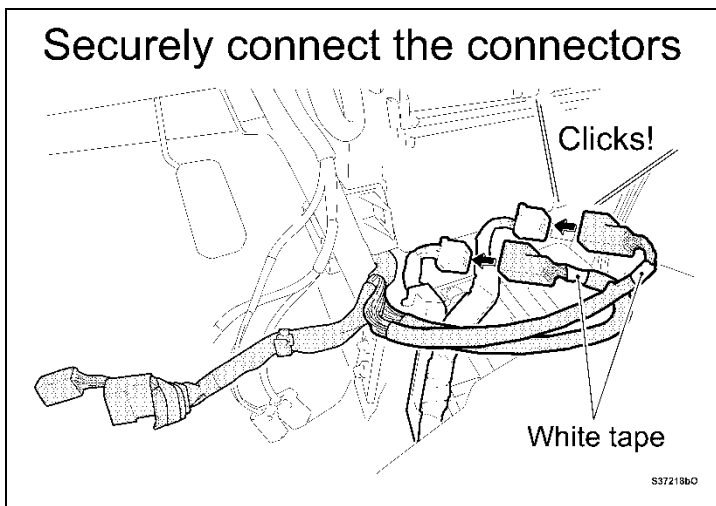

- d) Connect the 2 floor harnesses to the sub wire harness.

NOTE: Ensure that the 2 floor harness connectors are fully engaged into the sub wire harnesses.

OK

NG

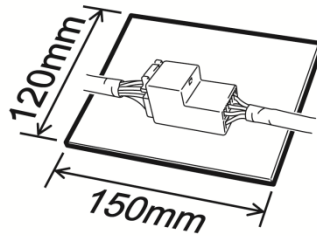
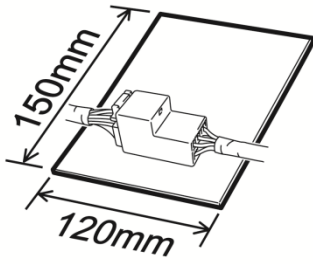

Wrap the connector

Press

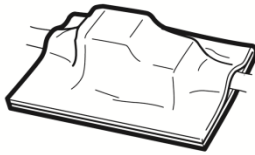
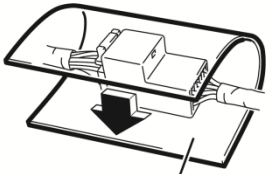

Water guard tape

S37325aO

- e) Using the small water guard tape, wrap each floor harness connector as shown.

NOTE: When wrapping the connectors ensure that the water guard tape is oriented correctly.

Ensure that the connector is completely sealed with the tape and there are no gaps to protect the connector, in case of water condensation from the HVAC unit.

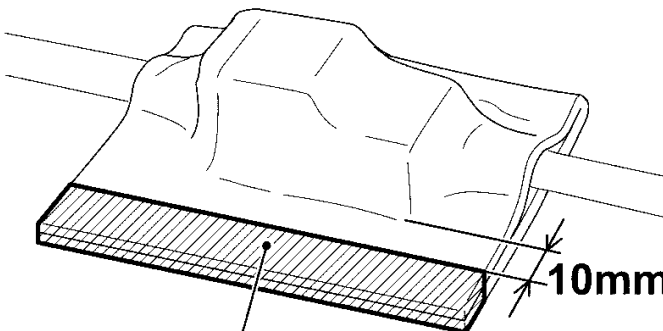

Cut off

S37326aO

- f) Cut off the highlighted portion of the water guard tape as shown. This will allow for both connectors to be stored under the HVAC unit.

NOTE: When cutting off the excess tape do not cut the wire harness.

Do not cut off more tape than is highlighted in the illustration.

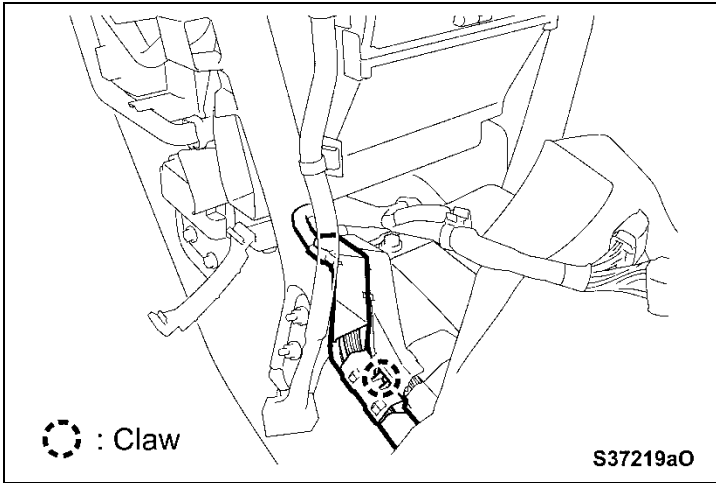

g) Engage the claw of the protector to fasten the wire harness.

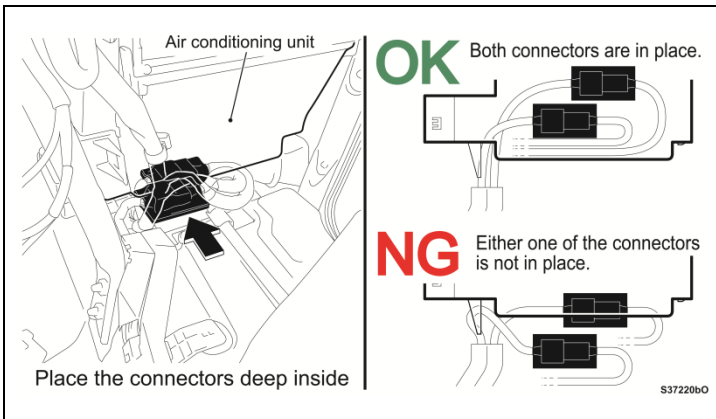

h) Place the 2 connectors under the HVAC unit as shown.

NOTE: Place the connectors as far back as possible this will allow enough clearance to reinstall the finish panel.

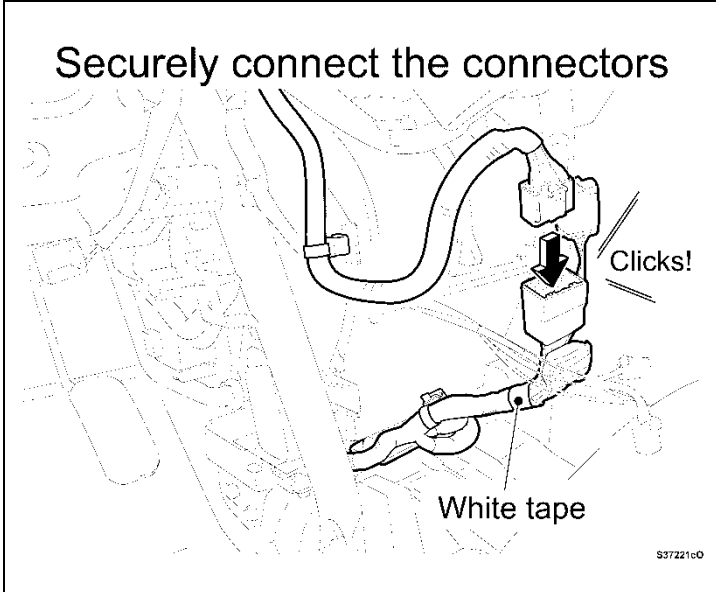

i) Connect the dash harness to the sub harness.

NOTE: Ensure that the dash harness connector is fully engaged into the sub wire harnesses connector with the white tape.

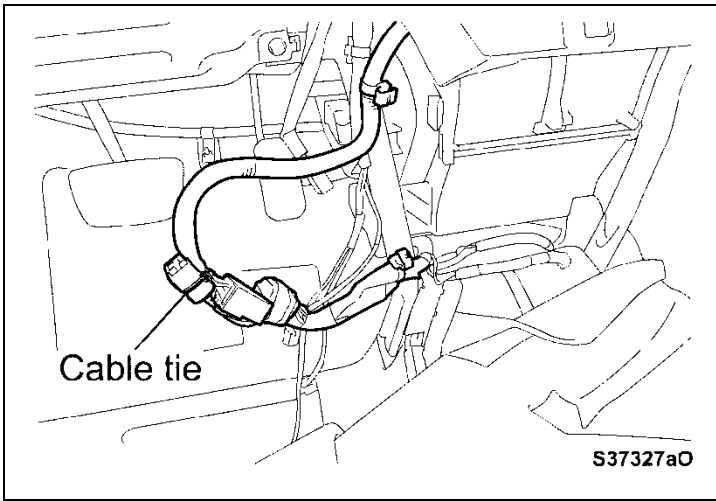

- j) Using a tie wrap. Wrap the diode pod to the dash harness.

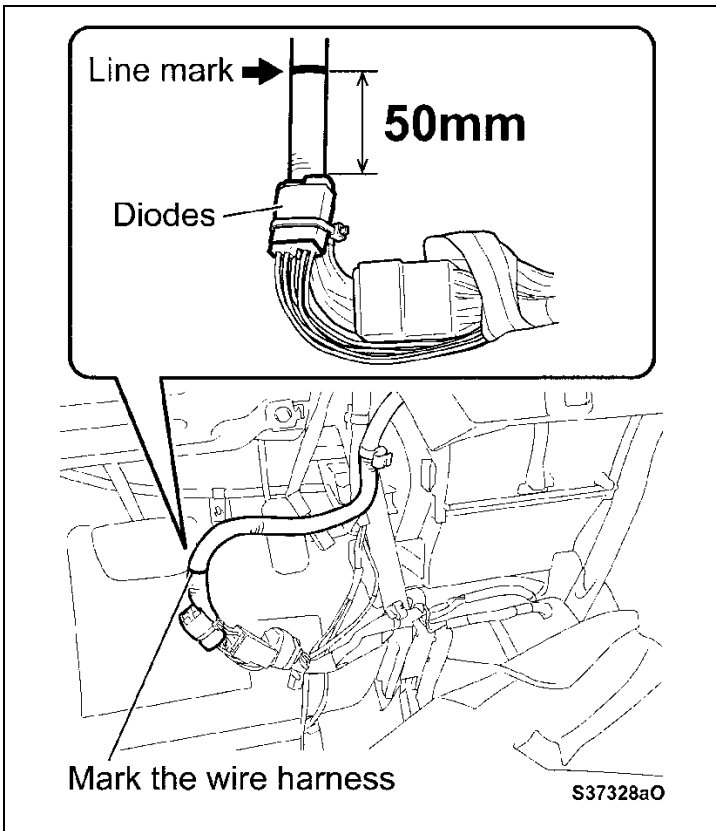

- k) Mark the dash harness as shown. Make a mark 50mm above the end of the diode pod.

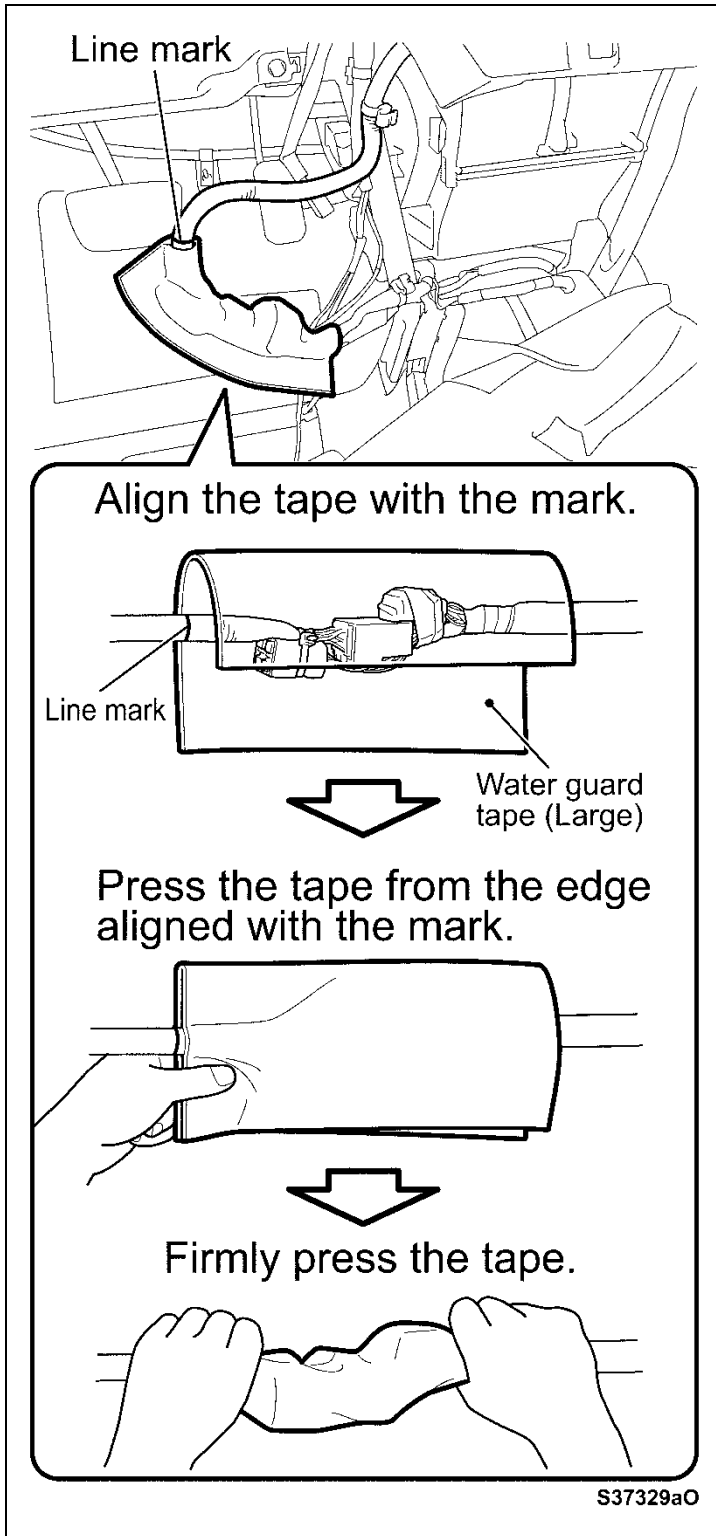

- 1) Protect the dash harness connection and diode pod with the large water guard sheet as shown.

NOTE: Ensure that the connector and diode pod are completely sealed with the tape and there are no gaps to protect the connector and diode pod, in case of water condensation from the HVAC unit.

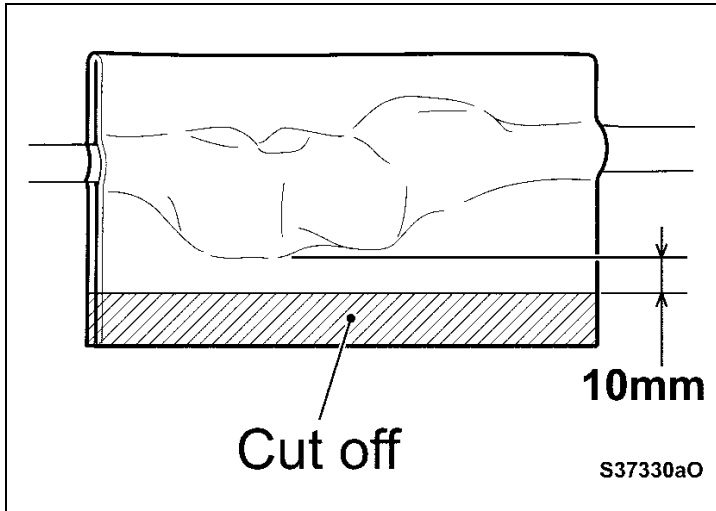

m) Cut off the highlighted portion of the water guard tape as shown. This will allow for connector storage.

NOTE: When cutting off the excess tape do not cut the wire harness.

Do not cut off more tape than is highlighted in the illustration.

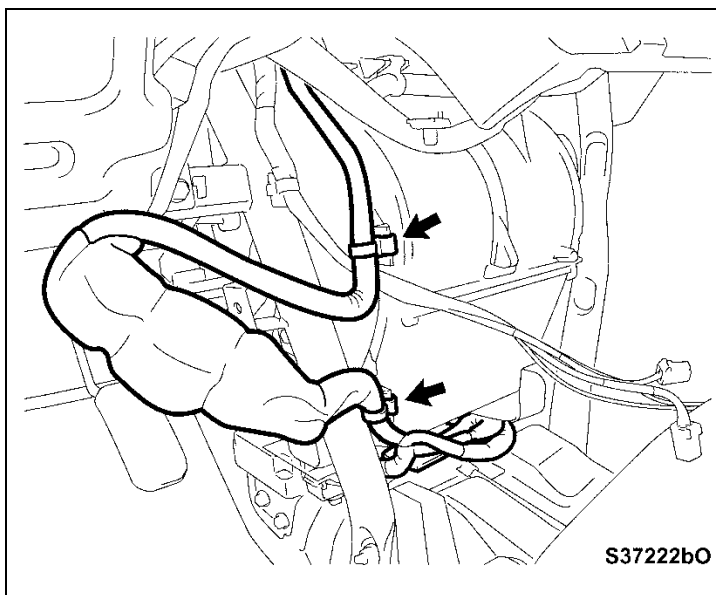

n) Install tie wraps onto the ribs of the HVAC unit as shown.

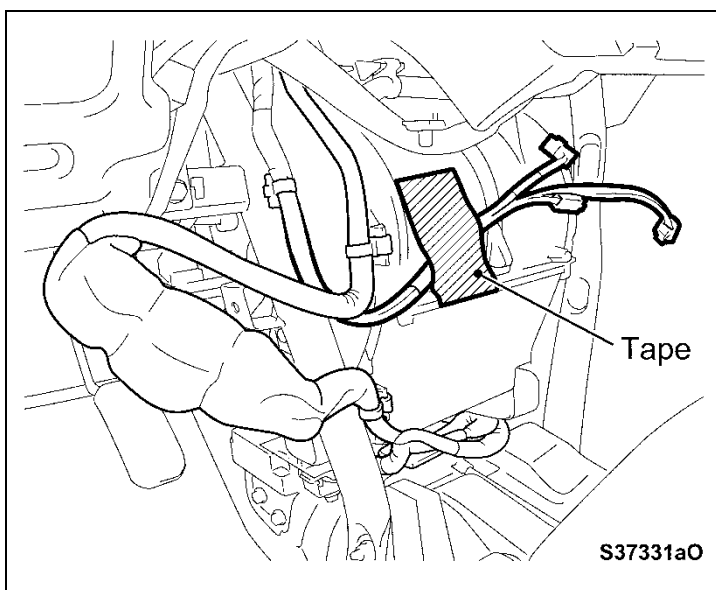

o) Temporarily attach the wire harness for the finish panel to the HVAC unit using tape.

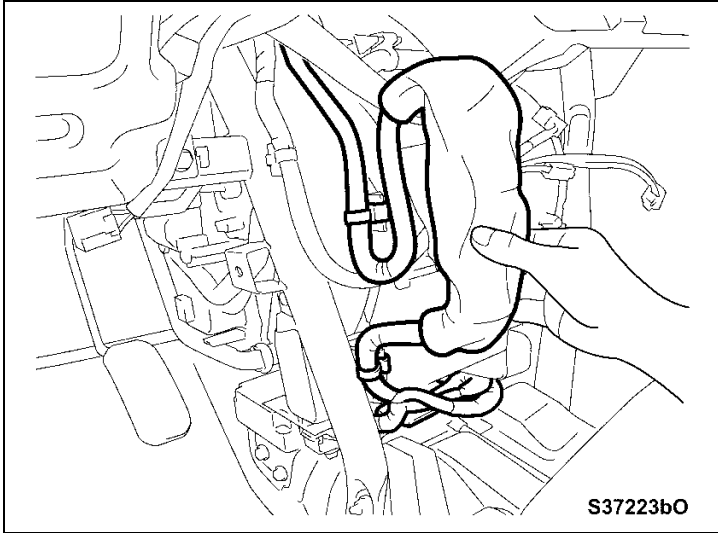

p) Route the dash and sub-harness as shown.

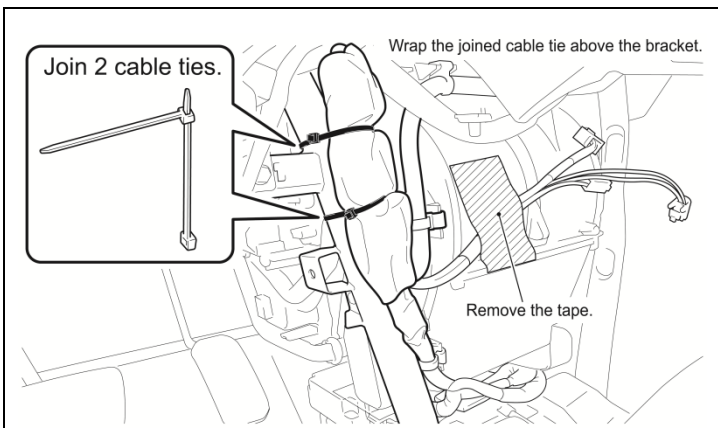

q) Using 4 tie wraps attach the dash/sub-harness to the dash brace as shown.

NOTE: To prevent the dash/sub-harness from moving place a tie wrap above the center bracket of the dash brace as shown.

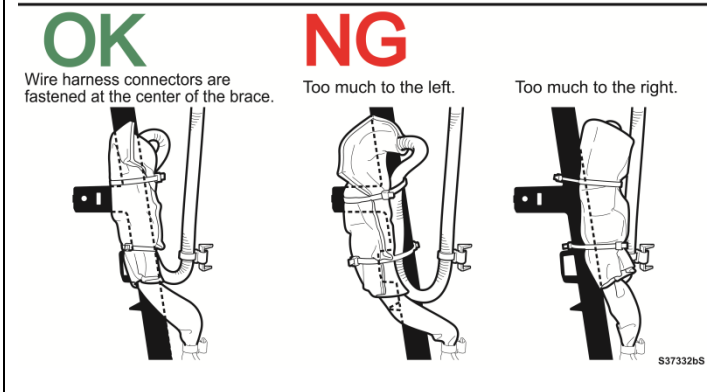

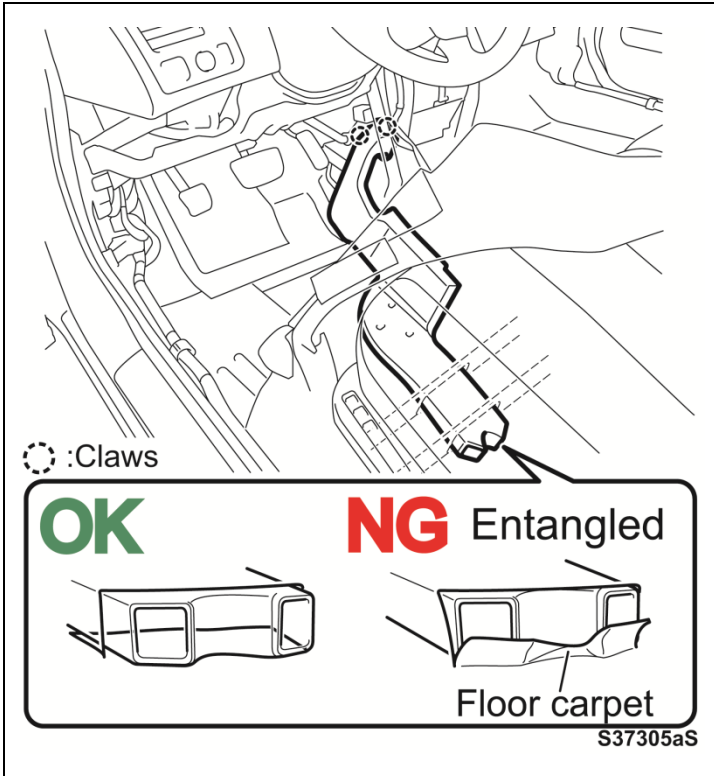

12. REASSEMBLE THE VEHICLE

a) Reinstall the left rear air duct.

- 1) Insert the air duct into the opening under the left front seat.

NOTE: To prevent the duct from being caught on the carpet, pull the duct from the rear of the seat. Ensure that the duct does not catch the carpet.

- 2) Connect the air duct to the HVAC unit.

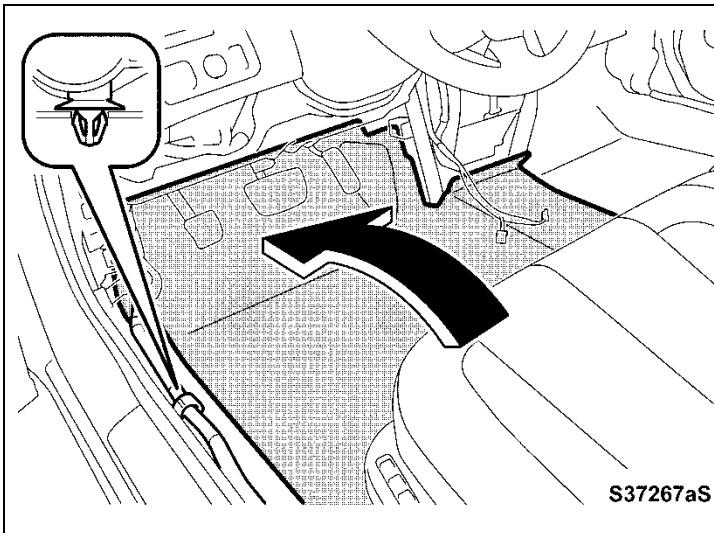

- b) Return the left front carpet to its original position and secure it to the bracket.



Ensure that the carpet is returned to its original position, and secured so that it does not interfere with pedal operation

- c) Reengage the claw for the floor harness clamp.

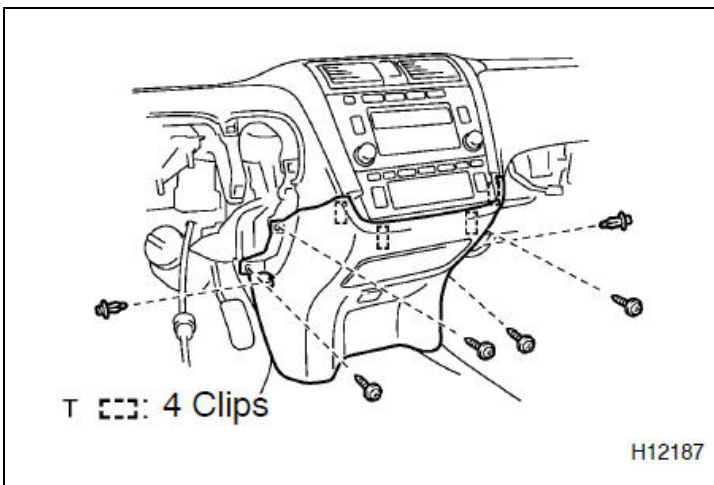

d) Reinstall the finish panel.

- 1) Reconnect the connector.
- 2) Reinstall finish panel.
- 3) Reinstall the following:
 - 4 screws
 - 2 clips

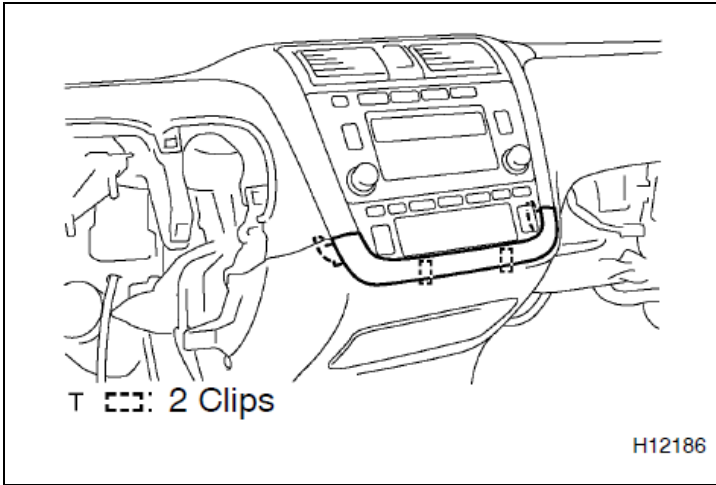

- e) Reinstall the lower cover.
- f) Reinstall the cowl side trim sub-assembly LH.
- g) Reinstall the left front floor footrest.

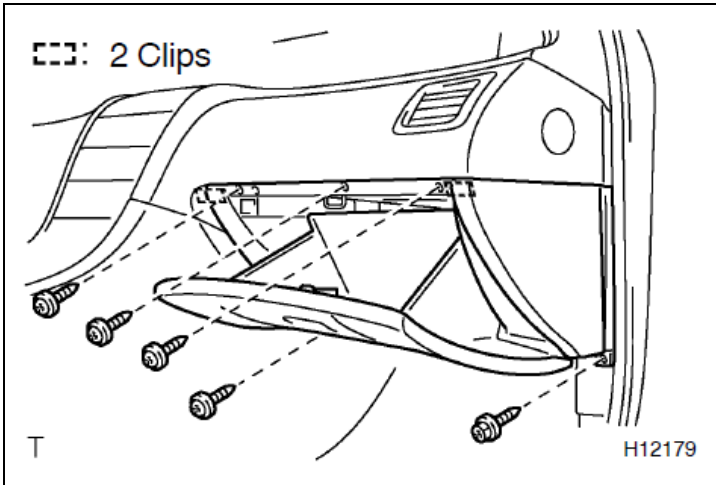

- h) Reinstall the glove box.
 - 1) Reinstall the 5 screws.

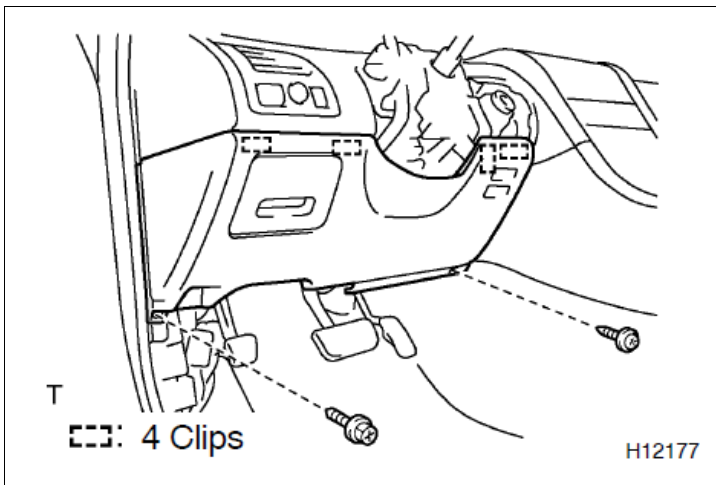

- j) Reinstall the No. 1 lower panel.
 - 1) Reinstall the 2 screws and hood lock release lever.

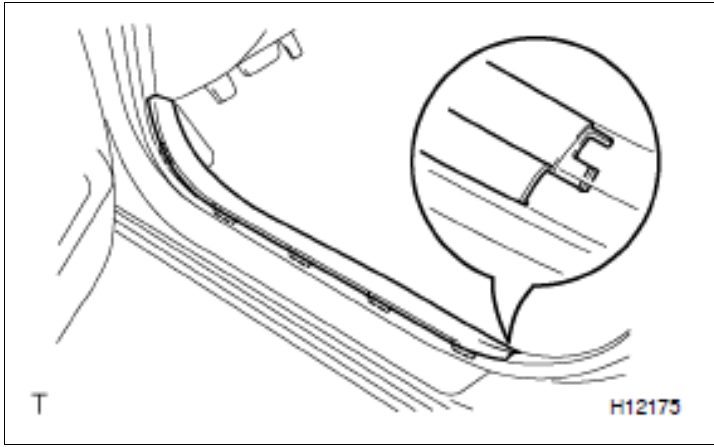

- k) Reinstall the left and right front door scuff plate.
- l) Reinstall the instrument panel under cover sub-assembly No.2.

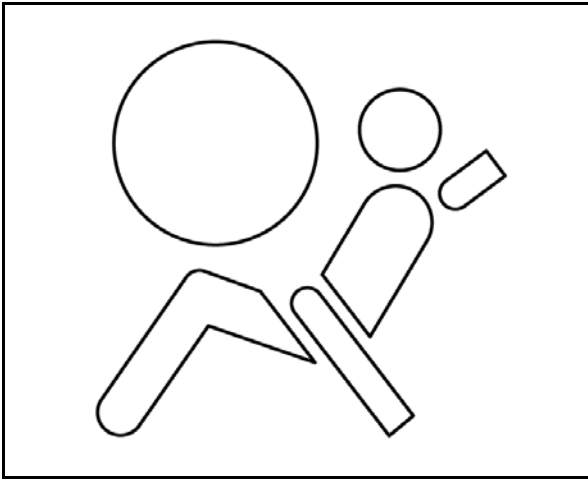

13. RECONNECT THE NEGATIVE BATTERY TERMINAL

14. CHECK THE AIRBAG WARNING INDICATOR

- a) Check that the warning indicator illuminates when the ignition is switched "ON".
- b) Confirm that the warning light will go off after about 6 seconds have elapsed after IG on.



- After the 6 second illumination of the warning indicator, if the indicator goes off then back on or remains on, check for DTCs and confirm the sub harness was installed correctly.
- Consult with the customer to determine if they would like to diagnose/repair any remaining concerns.

15. RESTORE VEHICLE SETTINGS

- a) Restore any memory settings and initialise any system needed (i.e. power windows, moonroof, etc.).
- b) Return the seats to their original positions.

◀ VERIFY REPAIR QUALITY ▶

- Confirm any DTCs prior to beginning this repair
- Read all precautions as outlined on TIS before servicing the SRS system
- Confirm **ALL** harness connectors are connected securely
- Confirm the water guard sheet is secured and positioned correctly
- Confirm there are no DTCs when the repair is complete

If you have any questions regarding this update, please contact your area representative.

VI. APPENDIX

A. CAMPAIGN DESIGNATION DECODER

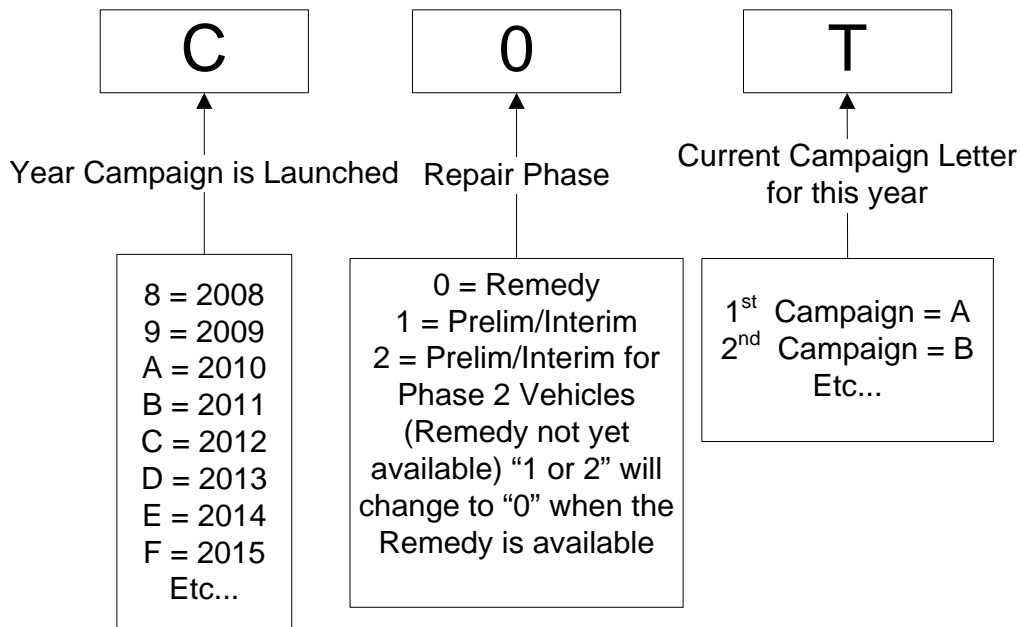

B. CAMPAIGN PARTS DISPOSAL

As required by Federal Regulations, please make sure all campaign parts (original parts) removed from the vehicle are disposed of in a manner in which they will not be reused, ***unless requested for parts recovery return.***