



January 15, 2016

## IMPORTANT SAFETY RECALL

This notice applies to your vehicle with VIN [insert number].

This **Notice** is sent to you in accordance with the requirements of the United States National Traffic and Motor Vehicle Safety Act.

[Addressee]

Subject: NHTSA Safety Recall Number 15E-068  
Defect: Ricon Platform  
Affected Units: Ameritrans Models 2012-2014 Ford E150 CTV, Ford E250 CTV, Ford E350 200, Ford E350 225, Ford E450 245, Ford E450 285, Freightliner M2 375 & Freightliner M2 395; from August 1, 2012, through July 10, 2014.

Ameritrans decided that a defect which relates to motor vehicle safety exists in certain Ameritrans buses assembled from August 1, 2012, through July 10, 2014 that have Ricon "S" 2000 and 5000 Series wheelchair lifts installed.

**This is a NEW RECALL from Ricon! Please READ carefully and following the instructions!**

Under certain conditions present in some applications, the platforms included on the potentially affected S-Series model wheelchair lifts can exhibit cracking of the platform pivot plate while in the stowed position resulting from bent [Knuckle Link Arm](#) and/or [DU Bearings](#) that have fallen out of their holes in the knuckle link arm. If left unchecked the platforms can develop cracks and can propagate to the point where the separation of the rear portion of the pivot plate occurs rendering the lift potentially in operable and possibly unsafe for the operator.

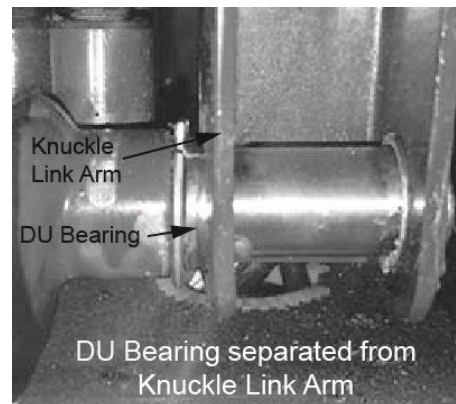
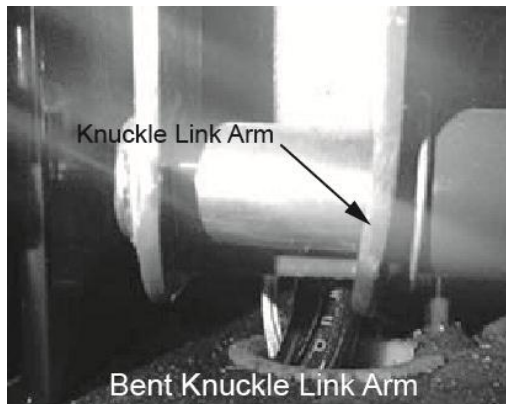

### What You Should Do

Please refer to the attached information from Ricon. Immediately locate and inspect the affected unit(s) in your fleet. If the inspected units are not found to have any bent Lower Knuckle Link Arms then no further action is required.

For units upon which inspection has found bent Lower Knuckle Link Arms, replacement of the Lower Knuckle Link Arm must be performed and a kit with the Lower Knuckle Link Arm Assembly will be provided by Ricon.

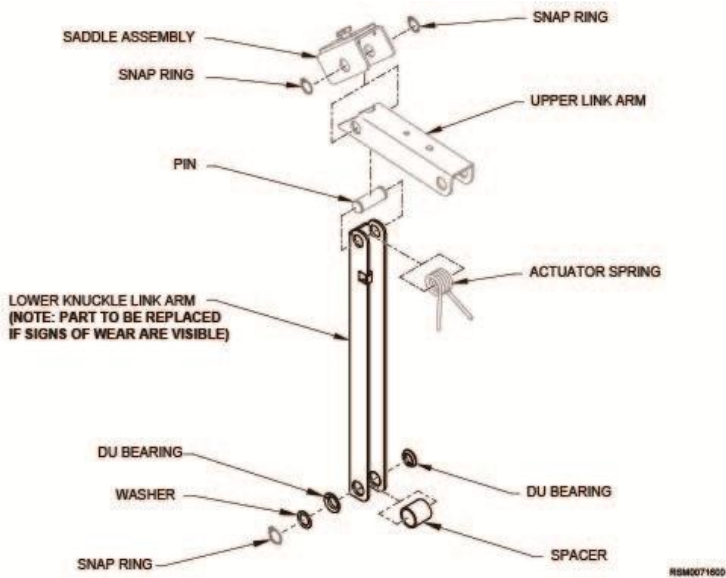

More information and instructions for this recall are below. For further assistance please email Ricon's Recall Coordinator, at [admin15E068@wabtec.com](mailto:admin15E068@wabtec.com) or call Customer Service at 800-322-2884. To locate the nearest Ricon servicing dealer please visit Ricon website: <http://www.riconcorp.com>.

### What Ricon Will Do

Ricon will provide a field modification instruction and all material required to mitigate this recall at no charge. It will be the responsibility of the lift owners to execute the mitigation.

If after attempting to have your vehicle repaired you believe you have not been able to have your vehicle remedied within a reasonable amount of time, you may submit a complaint to the Administrator, National Highway Traffic Safety Administration, 1200 New Jersey Ave., S.E., Washington, D.C., 20590; or call the toll-free Vehicle Safety Hotline at 1-888-327-4236 (TTY: 1-800-424-9153); or go to <http://www.safercar.gov>.

If you have previously paid for a repair that addresses the issue described in this letter, you still need to have this recall performed to ensure the correct parts and procedures were used.

Additionally, you may be eligible for a refund of previously paid repairs. Refunds will only be provided for service completed directly involved and described in this letter. For more information, please contact Ricon Customer Service at (800)322-2884.

Thank you for your prompt attention to this matter. If you have any questions concerning these procedures please contact Ricon Customer Service at (800)322-2884.

Federal regulations require that any vehicle lessor receiving this recall notice must forward a copy of this notice to lessee within 10 days.

We apologize for any inconvenience; however, we have taken this action in the interest of your safety and continued satisfaction with our buses.

Sincerely,

AMERITRANS BUS, INC.

# SAFETY RECALL NOTICE

January 20, 2016

## END USER - DRAFT

[End User]

RE: Defect Recall Notification Knuckle Link Arm Recall 15E-068

Dear [End User]:

This notice is sent to you in accordance with the requirements of the National Traffic and Motor Vehicle Safety Act. Ricon has determined that a defect which relates to motor vehicle safety exists in the Ricon wheelchair lift installed in your vehicle.

### **! I M P O R T A N T !**

- Your Ricon Wheelchair Lift is being recalled
- Contact Ricon Corporation immediately

#### WHAT IS BEING RECALLED:

Ricon DOT Public Use,"S" 2000, 5000 and 5500 Series lifts manufactured after January 1, 2006 equipped with platforms measuring 32"x51" and 34"x54". The affected population is comprised of six (6) primary model numbers:

S2005-XXXXXXXX
S2010-XXXXXXXX
S5005-XXXXXXXX
S5010-XXXXXXXX
S5505-XXXXXXXX
S5510-XXXXXXXX

The total number of lifts being recalled is 38,434.

#### WHY IS IT BEING RECALLED:

Under certain conditions present in some applications, the platforms included on the potentially affected S-Series model wheelchair lifts can exhibit cracking of the platform pivot plate while in the stowed position resulting from bent Knuckle Link Arm and/or DU Bearings that have fallen out of their holes in the knuckle link arm. If left unchecked the platforms can develop cracks and can propagate to the point where the separation of the rear portion of the pivot plate occurs rendering the lift potentially in operable and possibly unsafe for the operator.

WHAT YOU SHOULD DO:

Immediately locate and inspect the affected unit(s) in your fleet. If the inspected units are not found to have any bent Lower Knuckle Link Arms then no further action is required.

For units upon which inspection has found bent Lower Knuckle Link Arms, replacement of the Lower Knuckle Link Arm must be performed and a kit with the Lower Knuckle Link Arm Assembly will be provided by Ricon.

More information and instructions for this recall are below. For further assistance please email Ricon's Recall Coordinator, at [admin15E068@wabtec.com](mailto:admin15E068@wabtec.com) or call Customer Service at 800-322-2884. To locate the nearest Ricon servicing dealer please visit Ricon website: <http://www.riconcorp.com>.

WHAT RICON CORPORATION WILL DO:

Ricon will provide a field modification instruction and all material required to mitigate this recall at no charge. It will be the responsibility of the lift owners to execute the mitigation.

If after attempting to have your vehicle repaired you believe you have not been able to have your vehicle remedied within a reasonable amount of time, you may submit a complaint to the Administrator, National Highway Traffic Safety Administration, 1200 New Jersey Ave., S.E., Washington, D.C., 20590; or call the toll-free Vehicle Safety Hotline at 1-888-327-4236 (TTY: 1-800-424-9153); or go to <http://www.safercar.gov>.

Thank you for your prompt attention to this matter. If you have any questions concerning these procedures please contact Ricon Customer Service at (800)322-2884.

We apologize for any inconvenience this safety recall may cause, but your safety is our first concern.

Sincerely,

[Recall Administrator / Title]