



August 4, 2015

IMPORTANT SAFETY RECALL

This notice applies to your vehicle(s) [«UNIT»]

«CUST_NAME»

ATTENTION: TECH SERVICE DEPT/MAINT

«ADDRESS_1»

«CITY», «STATE» «ZIP»

SUBJECT: SAFETY RECALL: ZF DRIVE AXLE HUB CARRIERS

Ref.: **NHTSA # 15V-389**
NHTSA # (ZF RECALL) 15E-048
Transport Canada # 2015-263
MCI Service Bulletin 425

Attention Owner:

This notice is sent to you in accordance with the National Traffic and Motor Vehicle Safety Act and the Canada Motor Vehicle Safety Act.

Motor Coach Industries, Inc. (“MCI”) has decided that a defect which relates to motor vehicle safety exists in certain MCI model year 2014 D4500, 2013-2014 D4505, and 2013 – 2015 J4500 model coaches equipped with a ZF Friedrichshafen AG (“ZF”) A132 drive axles. ZF has notified MCI that the drive axle hub carriers may have porosities that could cause failure of the carrier, which could cause a loss of vehicle stability and increase the risk of a crash causing personal injury. Please see the enclosed MCI Service Bulletin 425 and attachments for additional information.

The vehicles that are subject to this notice are the following model year 2014 D4500, 2013-2014 D4505, and 2013 – 2015 J4500 model coaches (last five VIN digits):

12920	13151	13293	13311	13357
66554	66748	66796 – 66798	66823 – 66824	66826
66841 – 66842	66844	66960	67000 – 67088	67090 – 67169
67172 – 67213	67215	67222-67231	67233 – 67239	67245 – 67246

MCI is conducting a recall to have the above vehicles repaired at no cost to you. ZF will remedy the affected coaches by replacing the hub carriers, which ZF estimates will take approximately eight (8) hours per coach. Please see the enclosed MCI Service Bulletin 425 for additional

information, including the coach inspections that ZF recommends be performed until your affected coach or coaches have been repaired.

MCI records indicate that you are the owner or operator of the following vehicle(s) included in this recall: «UNIT»

MCI strongly urges you to have the recall work performed on your vehicle(s) as quickly as possible.

You may contact the MCI Customer Service Line at 1-800-241-2947 if you have any questions about this recall campaign. Submission of MCI Warranty Claim Forms may be completed on MCI's website at <http://fleetsupportiw.mcicoach.com/iwarranty/signon> (click on Customer Care System), or a photocopy of the Warranty Claim Form found in the Warranty Manual can be mailed / faxed to the MCI Warranty Department.

After contacting MCI Customer Service, if you are still unable to have the safety defect remedied without charge and within a reasonable time, you may submit a complaint:

For US customers:

You may submit a written complaint to the Administrator, National Highway Traffic Safety Administration, 1200 New Jersey Avenue, SE, Washington, DC 20590, or call 888 327-4236 (TTY: 800-424-9153), or go to <http://www.safercar.gov> if remedy difficulties exist.

For Canadian customers:

Please contact our customer service at 1-800-241-2947, or for additional information about the recall, you can contact Transport Canada at 1-800-333-0510.

If you are the lessor of the vehicle(s) identified above, Federal law requires that you forward this notice by first class mail to the most recent lessee(s) known to you, within ten days of your receipt of this notice.

If you have sold or otherwise transferred the vehicle(s) identified above, please contact the MCI Customer Service Line at 1-800-241-2947 with all of the information you have regarding the current owner/operator of the vehicle(s).

If you had your vehicle repaired for this condition prior to receipt of this notice and incurred any costs, you may be eligible for reimbursement. Please contact the MCI Customer Service Line at 1-800-241-2947 for further information in that regard.

We regret the inconvenience this may cause you, but urge you to implement the recall procedures with respect to your vehicle(s) as soon as possible for your added safety and satisfaction.

Sincerely,

Motor Coach Industries
Warranty Department

Enclosure: MCI SB 425 (w/ attachments)



Reliability Driven™

Service Bulletin No. 425

<i>MODEL</i>	D / J4500 Series	<i>TYPE</i>	Field Change Program	<i>SECTION/GROUP</i>	2-Axle	<i>DATE</i>	July 30, 2015
<i>SUBJECT</i>	ZF DRIVE AXLE HUB CARRIER						
<i>CONDITIONS</i>							

Ref. ZF NHTSA Recall No.: 15E-048

Ref. MCI NHTSA Recall No.:15V-389

Ref. MCI TC Recall No.:2015-263

Customer Complaint:

ZF Friedrichshafen AG ("ZF") has notified Motor Coach Industries ("MCI") that ZF is conducting a safety recall of its A132 drive axles. ZF reports that on certain A132 drive axles hub carriers may have porosities that could cause failure of the carrier.

This could cause a loss of vehicle stability, increasing the risk of a crash causing injury and/or damage to property. See the enclosed ZF notification letter, owner's certification letter, and A132 Bus Axle Repair Instruction.

Cause:

Vendor manufacturing processes.

Corrective Action:

ZF will remedy the affected coaches by replacing the hub carriers at no cost to customers. However, proper repairs will require the use of specialized equipment, and therefore MCI strongly urges customers to make an appointment as soon as possible by calling the MCI Customer Service Line at 1-800-241-2947, to have the repairs performed by trained technicians who have the necessary equipment. Coaches that are the subject of this recall are the following:

12920	13151	13293	13311	13357
66554	66748	66796 to 66798	66823 to 66824	66826
66841 to 66842	66844	66960	67000 to 67088	67090 to 67169
67172 to 67213	67215	67222 to 67231	67233 to 67239	67245 to 67246



Service Inspection

ZF recommends that your affected coach(es) be inspected until the hub carriers have been replaced.

ZF has determined that cracking in the carrier is visible with a careful visual inspection and is evidence that the carrier may be defective. ZF strongly recommends that your company immediately conduct visual inspections for such cracking evidence and if found, take appropriate precautions up to and including removing the affected coach(es) from service. **Inspections should be conducted every 6 weeks / 6000 miles** on each affected coach until the hub carriers have been replaced. Replacement carriers will be made available as promptly as possible.

Parts

Qty.	Old P/N	New P/N	Description
2		15-01-1321	Hub Carrier
2		02-01-1372	Locking Plate
a/r		23-01-0045	Grease
a/r		23-01-0046	Oil
a/r		15G-1-43	Torque Seal
a/r		0501-213-690	Shear Adapter
a/r		0501-324-804	ABS Sensor Bush
a/r		0501-321-356	Cable Clip, Speed Sensor Harness
a/r		4472-336-309	Screen Sheet

Service Procedure:



Read this entire procedure before beginning work.

Use Safe Shop Practices At All Times.



1. Turn the main battery disconnect switch to the OFF position.
2. Remove and retain the drive axle hub cover and lug nut covers from both sides of the drive axle wheels (as applicable per coach series). Carefully place aside to be re-installed at a later step in this procedure.
3. Position a jack under the drive axle jack pad, using the locations shown in Figure 1 or 2 on Pages 4 or 5 of this document, and partially raise the coach with the tire still contacting the ground.
4. Before the tire is completely off the ground, partially loosen the flanged wheel nuts.
5. Operate the jack to raise the drive wheels off the ground.

WARNING

To avoid personal injury, use caution when loosening the wheel nuts and when lifting the wheel off the hub as wheel and tire assemblies weigh more than 200 lbs.

NOTICE

To ensure correct installation of the drive axle wheels, clearly mark to identify the inner and outer wheels as well as the curbside or roadside locations.

Retain the wheel guard spacer ring for correct re-installation (refer to Figure 3).

6. Remove and retain the wheel nuts. Remove the wheels and wheel guard spacer from the drive axle hub and place aside to be re-installed at a later step in this procedure.

WARNING

DO NOT place safety stands in any other location than shown in this procedure and Section 3F in the MCI J4500 Maintenance Manual and Sections 3F and 3G in the MCI D Series Maintenance Manual.

7. Lift the coach to desired work height. Position safety stands underneath the coach in only the specified locations shown in Section 3F in the MCI J4500 Maintenance Manual and Sections 3F and 3G in the MCI D Series Maintenance Manual (as shown in Figures 1 and 2 on Pages 4 or 5 of this document).

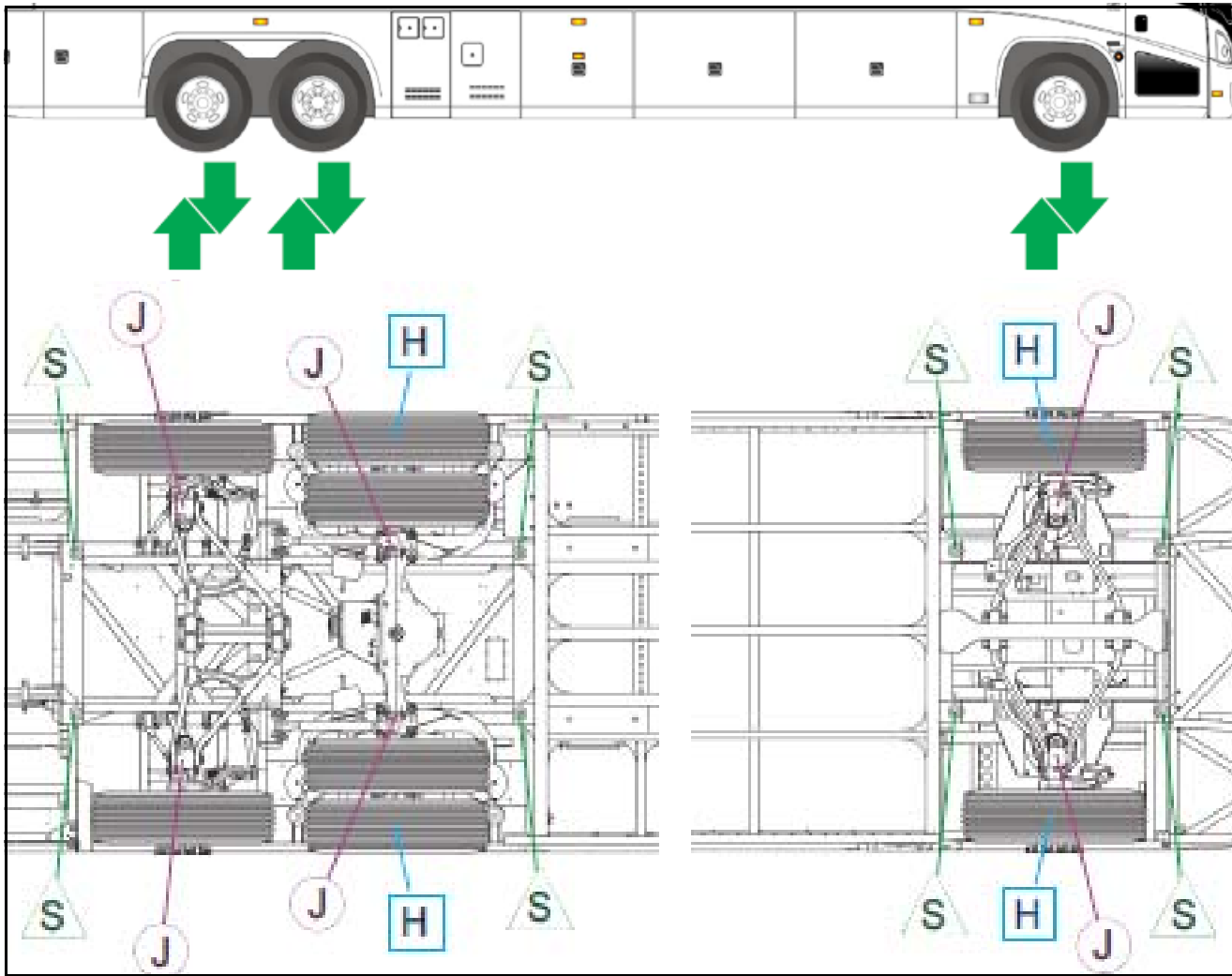

Figure 1. J4500 coach safety stands location.

Item	Figure 1 Description
S	Safety Stand (Primary locations)
J	Jacking Point
H	Hoisting Point

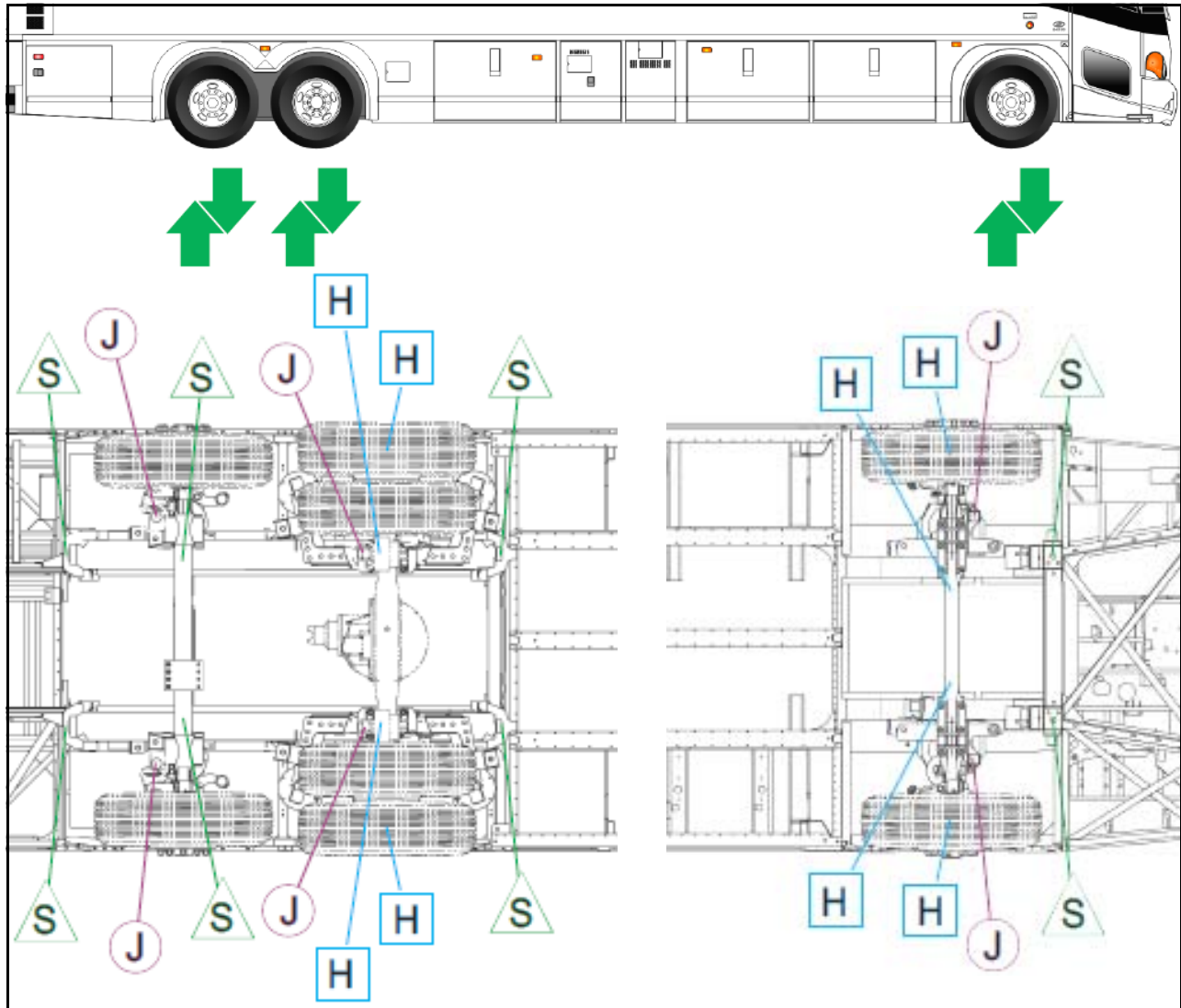

Figure 2. D Series coach safety stands location.

Item	Figure 2 Description
S	Safety Stand (Primary locations)
J	Jacking Point
H	Hoisting Point

CAUTION

To avoid potential internal damage to the wheel end, there must be no load on the wheel end when performing the outlined steps of this procedure.

Use a long handle, calibrated torque wrench to perform the outlined steps in this procedure.

DO NOT use an impact tool to perform the outlined steps in this procedure.

8. Proceed with Step 1 of the attached ZF A132 Bus Axle Repair Instruction Wheel Head Carrier Replacement Procedure, following all warnings and cautions therein.
9. Upon completion of the attached ZF A132 Bus Axle Repair Instruction Wheel Head Carrier Replacement Procedure, position the drive axle wheels and wheel guard spacer to their original installation location beside the coach.

NOTICE

Ensure that the wheel is squarely mounted against the hub prior to fully tightening the wheel nuts.

Orient and align the inner tire valve stem extension with the outer wheel hub (Figure 3).

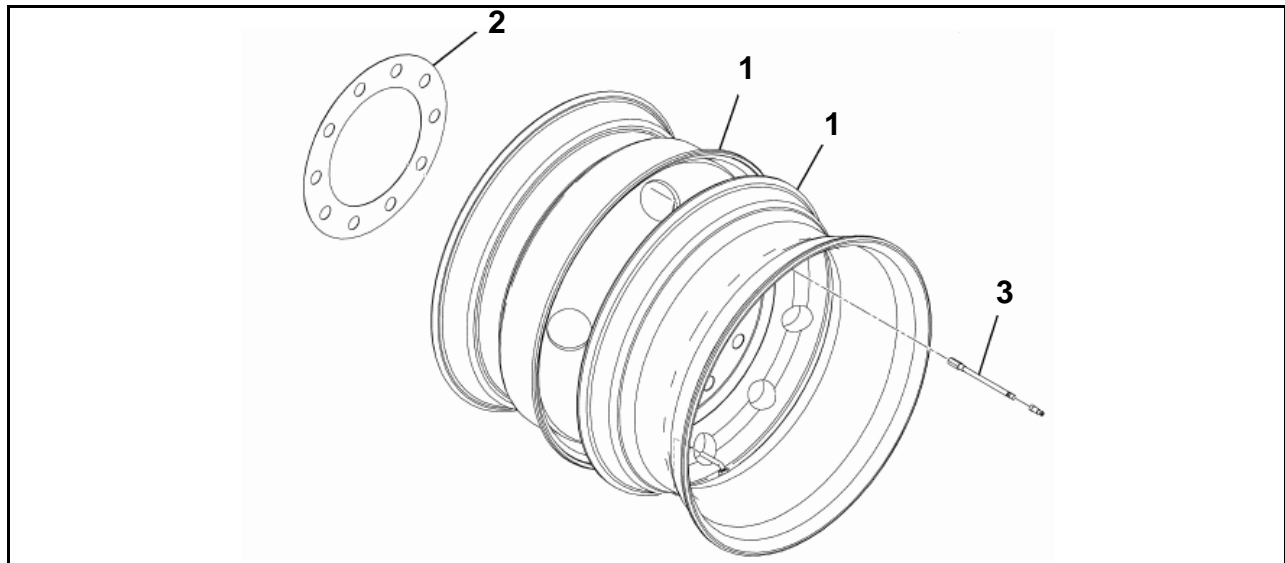

Figure 3. Drive axle wheel installation.

Item	Figure 3 Description
1	Wheel
2	Wheel guard spacer
3	Valve stem extension



WARNING

To avoid personal injury, use caution when lifting the wheel on the hub as wheel and tire assemblies weigh more than 200 lbs.

10. Re-install the drive axle wheels and wheel guard spacer. Using a calibrated torque wrench, torque wheel nuts to 450-500 ft-lbs. using a criss-cross sequence.
11. Re-install the drive axle hub cover and lug nut covers (as applicable per coach series).
12. Perform a road test on the coach.
13. Using a calibrated torque wrench, re-torque wheel nuts to 450-500 ft-lbs. using a criss-cross sequence.

Procedure Complete.

Mail or fax the completed limited warranty claim form and verification form to MCI's warranty department, or photocopy and mail to:

MCI Fleet Support
Attn: Warranty Department
7001 Universal Coach Drive
Louisville, KY 40258
Fax Number 1-800-360-8886

to receive credit for the hours used to complete this task. Contact the MCI Fleet Support Technical Center at 1-800-241-2947 for any further information.

Field Change Program Conditions:

The parts required for this change will be supplied without charge.

Specialized equipment is required to perform this campaign.

A labor allowance of 4.0 hours per side per axle will be granted for the procedure of replacing the drive axle hub carrier on affected D Series and J4500 Series coaches.

This labor allowance will be credited to your MCI Fleet Support Parts Account on receipt of the attached "MCI Field Change Program Verification Form" and a "Warranty Claim Form" as detailed in your Owner Warranty manual to MCI's Warranty department. A "MCI Field Change Program Verification Form" needs to be submitted for each VIN affected. Photocopy the attached "MCI Field Change Program Verification Form" as required for the number of affected coaches in your fleet.

Motor Coach apologizes for any inconvenience resulting from this campaign, but urges you to implement this change as soon as possible.

Sincerely,

Motor Coach Industries



Reliability Driven™

MCI FIELD CHANGE PROGRAM (FCP) VERIFICATION

CONTACT INFORMATION	
CUSTOMER NAME: _____	
<small>(PLEASE PRINT)</small>	
FCP INFORMATION – ONE FORM PER UNIT	
FCP#: _____	Coach Model _____ Model Year _____
COACH SERIAL #: <small>(At least the last 5 digits)</small>	DATE COMPLETED __ / __ / __
MILEAGE:	
<u>IMPORTANT:</u> TO RECEIVE CREDIT FOR ANY ALLOWABLE LABOR CHARGES, THIS VERIFICATION FORM MUST BE RETURNED TO MCI UPON COMPLETION OF THE FCP.	
SUBMITTED BY: (Please Print) _____	
	DATE __ / __ / __
TITLE: (Please Print) _____	
SIGNATURE: _____	
COMMENTS: 	

FAX TO: 800-360-8886

MAILING ADDRESS:

**MOTOR COACH INDUSTRIES
ATTN: WARRANTY DEPT.
7001 UNIVERSAL COACH DRIVE
LOUISVILLE, KY 40258**

MCI part # 03-15-7738C



Commercial Vehicle
Technology
Axle and Transmission
Systems for Bus and Coach

ZF North America, Inc. · 777 Hickory Hill Drive
Vernon Hills, IL 60061

Motor Coach Industries
Mr. Dan Besserer
200 East Oakton Street
Des Plaines IL, 60018

Dept. TUN
From Frank Schelkle
Phone +1 224 415 0441
Fax
E-mail Frank.Schelkle@zf.com
Your Ref.
Our Ref. 15E048 ZF campaign
Date 7/8/2015

IMPORTANT SAFETY RECALL

OWNER'S NOTIFICATION LETTER

IMPORTANT MESSAGE PLEASE READ IMMEDIATELY

RE: ZF Drive Axle A132 Recall (NHTSA Campaign No. 15E048)

Dear Coach Owner:

This notice is sent to you in accordance with the National Traffic and Highway Transportation Safety Administration Rules and the federal Motor Vehicle Safety Act.

ZF Friedrichshafen AG ("ZF") has decided that a defect potentially related to motor vehicle safety exists in certain coaches manufactured between **October 2014** and **May 2015** equipped with ZF drive axles.

The following coach models are affected within the specified production range dates:

US

D4500: 12/19/2013 to 04/14/2014

D4505: 02/01/2013 to 04/22/2014

J Series Model: 11/26/2013 to 05/22/2015

CANADA

J Series Model: 01/20/2014 to 05/21/2015

ZF North America, Inc.
777 Hickory Hill Drive
Vernon Hills, IL 60061
Phone 1-847-478-6726



ZF has determined that on certain A132 drive axles some hub carriers may have porosities that could cause failure of the carrier. Based on our findings made during rough transport testing and bench tests, noise, vibration and fluid leakage from the hub or axle will provide an early recognition of a failure.

The likely failure mode is: Crack initiating from the porosity → oil leakage + a run-out error → vibration/noise development while braking → the driver recognizes the problem and brings the vehicle to a safe stop. The brake components will support the hub carrier for a sufficient time to permit recognition and a controlled emergency stopping of the vehicle without spontaneous wheel loss. Therefore to prevent failure, ZF as manufacturer of the drive axle A132 has to notify you that action is necessary to exchange the drive axle wheel hub carriers on both sides of the coach. This exchange will be in accordance without charge of the coach owners.

Service inspection:

ZF has determined that cracking in the carrier is visible with a careful visual inspection and is evidence that the carrier may be defective. ZF strongly recommends that your company immediately conduct visual inspections for such cracking evidence and if found, take appropriate precautions up to and including removing the busses from service. **Inspections should be conducted every 6 weeks/6,000 miles** on each vehicle until the hub carriers have been replaced. Replacement carriers will be made available to your service centers as promptly as possible.

The exchange of the wheel hub carriers takes approximately 3hr per coach (With a team of three technicians) and requires lifting up the coach.

MCI has agreed to assist ZF in the initial notification to affected customers.

The subject axles were installed in the following MCI motor coaches:

VINS US

D4500: 13151, 13293, 13311

D4505: 12920, 13357

J Series: 66554, 66796-66798, 66823-66824, 66826, 66841-66842, 66844, 66960, 67000-67050, 67052-67088, 67090-67101, 67106-67107, 67109-67149, 67151-67169, 67172-67186, 67188, 67190-67199, 67201-67209, 67211-67213, 67222-67226, 67228-67229, 67231, 67233-67239, 67245

CANADA

J Series: 66748, 67051, 67102-67105, 67108, 67150, 67187, 67189, 67200, 67210, 67215, 67227, 67230, 67246



Please contact MCI at **1-800-241-2947**, as soon as possible to schedule a repair at your facility, ZF Service or MCI service center, or for assistance in locating a qualified service facility in your area to complete this safety recall campaign.

If you have sold or traded your motor coach, please call **1-800-241-2947**.

If you had this repair performed before you received this letter, you may be eligible to receive reimbursement for the cost of obtaining a pre-notification remedy of the problem associated with this recall. For more information contact MCI at **1-800-241-2947**.

If these updates are completed by your facility, please fill out the enclosed (Owner's Certification Letter) and return it in the self-addressed stamped envelope.

Liability of ZF or its affiliates and subsidiaries, will be limited to the taking at their charge of the cost of material and labor only, no additional reimbursement will be made.

In case of an execution of the wheel hub carrier exchange at your location with the assistance of the end customer technicians ZF will reimburse with a flat rate of: US\$75.00/hr (includes all overhead costs up to a maximum of 8hr/vehicle!)

If you are unable to have the safety related defect/non-compliance remedied without charge, and within a reasonable time, you may notify; the Administrator, National Highway Traffic Safety Administration, 1200 New Jersey Avenue SE., Washington, DC 20590 (or call 1-888-327-4236); (TTY: 1-800-424-9153); or go to <http://www.safercar.gov>.

For practical arrangements, additional information, questions, comments or if you do not operate any of the above coaches, please contact MCI:

Motor Coach Industries
Mr. Dan Besserer
200 East Oakton Street
DesPlaines IL, 60018
toll free # : (800) **241-2947**



Federal regulations require that any vehicle lessor receiving this recall notice must forward a copy of this notice to the lessee within (10) days.

We apologize for any inconvenience this may cause; however, this action is taken in the interest of your safety. If you need assistance, or if you have questions, please call the undersigned.

Sincerely,

ZF Friedrichshafen AG

A handwritten signature in black ink, appearing to read 'F. Schelke', written over the printed name.

Frank Schelke
Customer Service Bus Driveline Technology

Enclosures

1. ZF Service & Inspection instruction for the exchange of the wheel hub carrier
2. Owner's Certification Letter



**Commercial Vehicle
Technology**
Axle and Transmission
Systems for Bus and Coach

ZF North America, Inc. · 777 Hickory Hill Drive
Vernon Hills, IL 60061

? Address ?

Dept. TUN
From Frank Schelkle
Phone +1 224 415 0441
Fax
E-mail Frank.Schelkle@zf.com
Your Ref.
Our Ref. 15E048 ZF campaign
Date 7/8/2015

OWNER'S CERTIFICATION LETTER

ATTENTION:
Motor Coach Ind
Mr. Dan Besserer
200 East Oakton Street
DesPlaines IL, 60018

Re.: NHTSA Safety Recall Program-Campaign number **15E048 Campaign**
(Connection between the wheel end/hub and the bare axle; wheel hub carrier of the ZF drive axle A132)

We wish to inform you that the MCI motorcoach(es) with the last five digits of the VIN # being:

Has (have) been inspected every 6.000 miles/6 weeks for oil leaks at the ZF drive axle A132 wheel hub carrier following your inspection guidelines.

The ZF drive axle has also been modified in regards of exchanging both wheel hub carriers retrofitted in our workshop or the MCI/ZF Service center in accordance following the ZF/MCI service instructions.

The above detailed work was completed on _____ (date).

OWNER's signature: _____

OWNER's name (print): _____

Date: _____



A132

Bus Axle

Repair Instruction Wheel

Head Carrier

Replacement

Structure of the Service Manual

The structure of this manual reflects the sequence of work steps for completely dismantling the removed unit.

Important information on work safety

As a basic principle, the workshop carrying out the repair or maintenance of ZF units shall be fully responsible for work safety.

The observance of all valid safety regulations and legal requirements is a prerequisite for avoiding any damage to persons and products during maintenance and repair work.

Repair workshops must familiarize themselves with these regulations prior to starting any work.

A suitably trained and skilled staff is required for a proper repair of these ZF products.

The repair workshop shall be responsible for the training.

The following safety references are used in this manual:

 CAUTION	This symbol serves as a reference to special working procedures, methods, information, use of auxiliaries etc... indicated in this repair manual.
--	--

 DANGER	This symbol identifies situations in which lacking care may lead to personal injury or damage to the product .
---	---

NOTE:	Thoroughly study this manual before starting any tests and repair work.
--------------	---

NOTE:	Figures, drawings and parts in this manual do not always represent the original; they show the working procedure. Since the figures, drawings and parts are not shown to scale, do not draw any conclusions on size and weight (not even within one and the same illustration). Carry out work according to the legend.
--------------	---

NOTE:	After repair work and tests, the expert staff must verify that the product is functioning perfectly again.
--------------	--

NOTE:	All screws must represent that they have been torqued to the correct specification with the use of Torque Seal Paint across the face of the screw and body of the housing.
--------------	--

NOTE:	Before starting this task the technician MUST collect the following technical data: <table><tr><td>1. The vehicle manufacturer</td><td>4. The vehicle operator</td></tr><tr><td>2. The vehicle chassis number</td><td>5. The ZF axle part number</td></tr><tr><td>3. The vehicle mileage</td><td>6. The ZF axle serial number</td></tr></table> Labor times are set: 4 hours / Wheel Head 8 Hours / Axle	1. The vehicle manufacturer	4. The vehicle operator	2. The vehicle chassis number	5. The ZF axle part number	3. The vehicle mileage	6. The ZF axle serial number
1. The vehicle manufacturer	4. The vehicle operator						
2. The vehicle chassis number	5. The ZF axle part number						
3. The vehicle mileage	6. The ZF axle serial number						

TIGHTENING TORQUES FOR SCREWS (in Nm) ACC. TO ZF STANDARD 148

Friction coefficient: μ tot. = 0.12 for screws and nuts without subsequent treatment, as well as for phosphated nuts. Tighten manually!

Unless otherwise specified, the tightening torques can be taken from the following chart:

Metric ISO standard thread DIN 13, page 13

Dimension	8.8		10.9		12.9
M4	2.8		4.1		4.8
M5	5.5		8.1		9.5
M6	9.5		14		16.5
M7	15		23		28
M8	23		34		40
M10	46		68		79
M12	79		115		135
M14	125		185		215
M16	195		280		330
M18	280		390		460
M20	390		560		650
M22	530		750		880
M24	670		960		1100
M27	1000		1400		1650
M30	1350		1900		2250
M33	1850		2600		3000
M36	2350		3300		3900
M39	3000		4300		5100

Metric ISO fine thread DIN 13, page 13

Dimension	8.8		10.9		12.9
M 8 x 1	24		36		43
M 9 x 1	36		53		62
M 10 x 1	52		76		89
M 10 x 1.25	49		72		84
M 12 x 1.25	87		125		150
M 12 x 1.5	83		120		145
M 14 x 1.5	135		200		235
M 16 x 1.5	205		300		360
M 18 x 1.5	310		440		520
M 18 x 2	290		420		490
M 20 x 1.5	430		620		720
M 22 x 1.5	580		820		960
M 24 x 1.5	760		1100		1250
M 24 x 2	730		1050		1200
M 27 x 1.5	1100		1600		1850
M 27 x 2	1050		1500		1800
M 30 x 1.5	1550		2200		2550
M 30 x 2	1500		2100		2500
M33 x 1.5	2050		2900		3400
M 33 x 2	2000		2800		3300
M 36 x 1.5	2700		3800		4450
M 36 x 3	2500		3500		4100
M 39 x 1.5	3450		4900		5700
M 39 x 3	3200		4600		5300

SPECIAL TOOLS FOR DISASSEMBLY AND REASSEMBLY

A-132

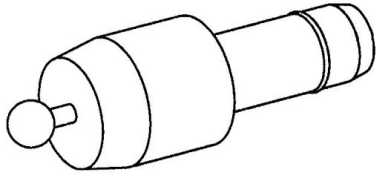

Assembly Aid

5870.651.085

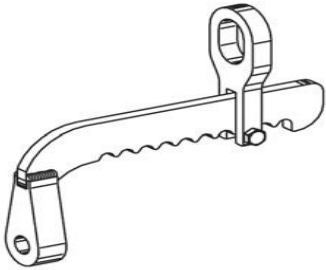

Load Carrying Fixture

5870.281.043

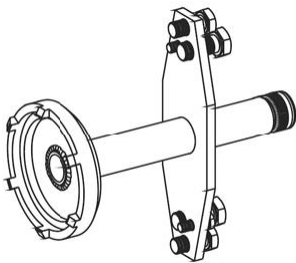

Slotted Nut Wrench

5870.401.146

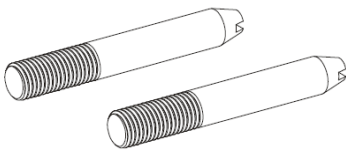

Locating Pins

5870.204.029

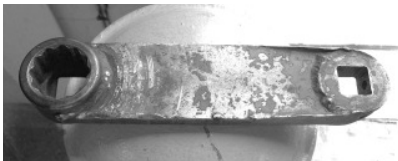

Torque Adaptor 30mm

ZF Special Tool



Torque Adaptor 27mm

ZF Special Tool

Note:

Due to the nature of this repair and the low miles that these vehicles have covered it has been decided that the oil currently in the axle **WILL BE REUSED** and should be drained into a clean container before dis-assembly of the axle begins.

**1. Removing the oil from the axle.**

Using a 19mm or 3/4" Allen key socket remove the sump plug and drain down the oil in the axle into a clean dry and water free container.

Note: This volume is approximately 4.5 Gallons therefore ensure your container is large enough.

This oil is going to put back in the axle when the replacement is complete.

Note:

The brake manufacturer's instructions and specifications are mandatory for any operations done on the brake system!

The relating information is included in the repair, maintenance and service manuals of the component manufacturer!

The applicable instructions are to be requested from the brake manufacturer or can be viewed on the brake manufacturer's website!

Brake manufacturer and brake type are indicated on the identification plate of the brake caliper!

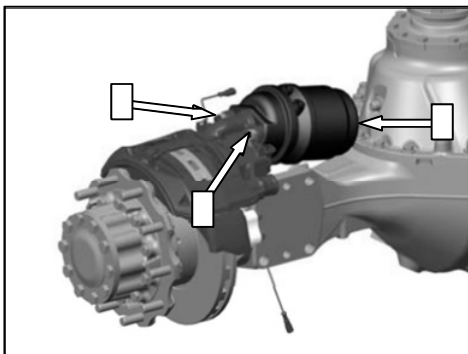
2. Disassembly of brake cylinder and brake caliperRemoving the Brake Chamber.

Place vehicle on a suitable vehicle lift where the wheels can be removed in a safe manor and parking brake is disengaged.

Remove both the 24mm nylon locking nuts holding the air brake chamber to the brake caliper and secure the chamber out of the working area.

Note: Make sure none of the electrical wiring to the ABS circuits are damaged and unplug the wear detection connectors at this point.

If relevant remove wear indicator connection at the caliper.

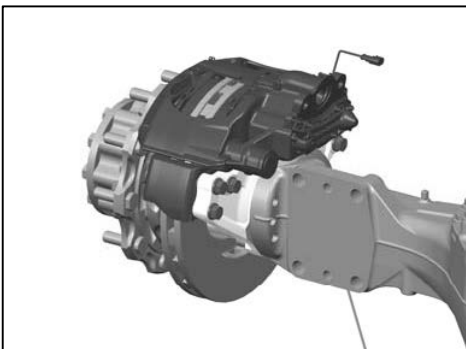
Removing the Brake Caliper Assembly

Using a short 10mm wrench back off the brake adjuster enough to pull the brake pads over any beading on the edge of the brake rotor.

Using special torque adaptors to remove the caliper carrier bolts, safely remove the brake caliper in upward direction using suitable lifting equipment.

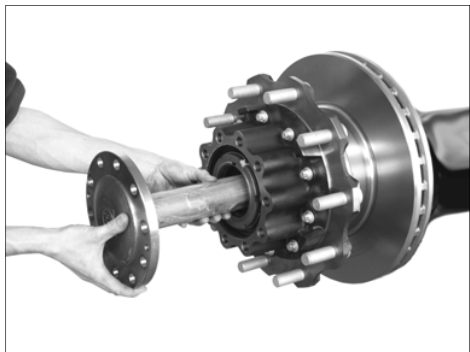

3. Disassembly of hub

Removing the Flange Shaft

Using a 14mm Allen Key Socket Loosen and remove all the screws from the flange shaft.

Pull flange shaft out of the axle using a tire lever on the end of one of the lug nut studs to the back of the flange.

Note: Be prepared this is a relatively heavy item. Place in a safe area where it will not be damaged.

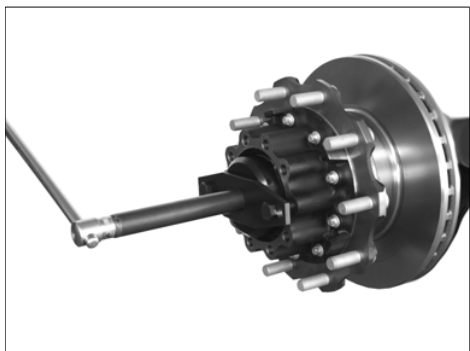

Remove the lock nut assembly.

Using a pin punch push the staked lock tab from the slot on the outer slotted nut far enough that the slotted nut is able to spin. (Tightened to 1200N/m (885 lbf.tf))

Using the special tool (5870 401 146) to loosen and remove the outer slotted nut and locking plate.

Again using the special tool (5870 401 146) loosen and remove the inner slotted nut (tightened to 850N/m (630 lbf.tf))



Remove the wheel Head.

Using a safe method of working, carefully remove the wheel head assembly and set aside.

Note: The provision of a special tool for lifting the wheel head assembly has been included in the special ZF tool kit.

In addition to this a lifting table makes the perfect substitute (see recommendations)

(S) Load carrying fixture 5870.281.043

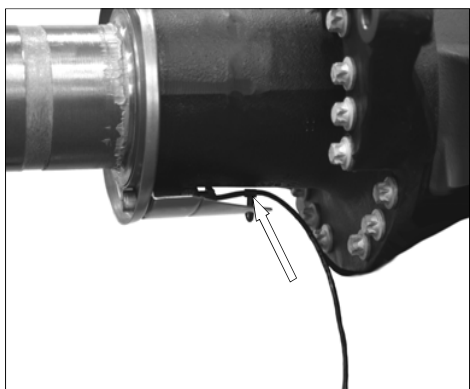

4. Disassembly of hub carrier

Removing the wheel head carrier

Remove the ABS sensor by first detaching the cable from the clamp and remove clamp from the screen sheet (dust cover) see arrow.

Push out the sensor and bushing towards the axle bridge.

Gently remove the screen sheet from the hub carrier Using a hammer and drift around the circumference of the tube,

Note: There is provisions in your kit to replace the screen sheet if the old item gets damaged removing it. Please try to re-use the original.

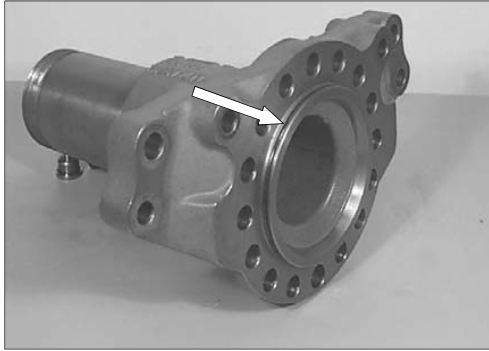

5. Reassembly of hub carrier

Take a new wheel head carrier from stock

Lubricate the O-ring (see arrow) and insert it into the annular groove on the hub carrier.

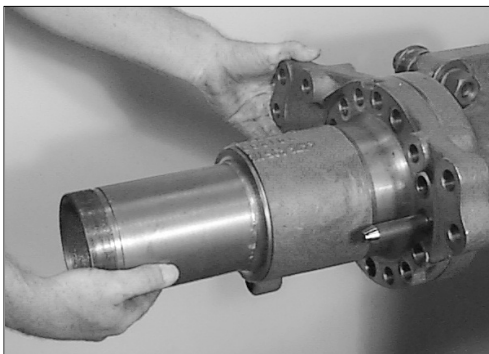

Slide the replacement wheel head carrier on to the locations pins (5870.204.029) as shown.

Fix wheel head carrier with cylindrical screws and washers making sure not to trap the o'ring.

Tightening torque (M18x1.5/10.9) $M_A = 440 \text{ N/m}$
 $= 325 \text{ lbf.tf}$

Note: Ensure correct installation position.

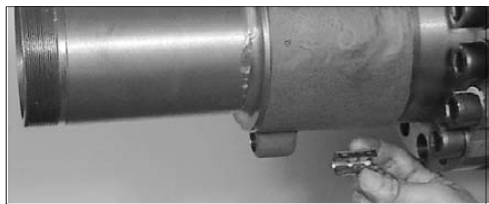

Reinstalling the ABS sensor assembly

Re-install ABS Sensor bushing into the hole on the hub carrier.



Re-install the ABS sensor by pushing the sensor in until it stops.

The sensor depth is set when the wheel head is fitted so cannot be incorrect unless it is not pushed all the way in at this stage.

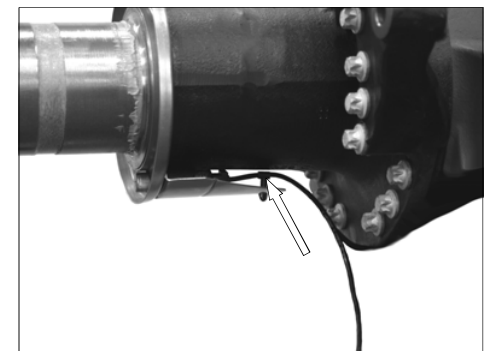

Refitting the Screen Sheet

Refit the original screen sheet or replace with a new item if old one was damaged during dis-assembly. This can be fitted by lightly tapping it on with a small hammer and soft punch until the shoulder is seated.



Note: Ensure that the ABS sensor wiring route is correct at this point.

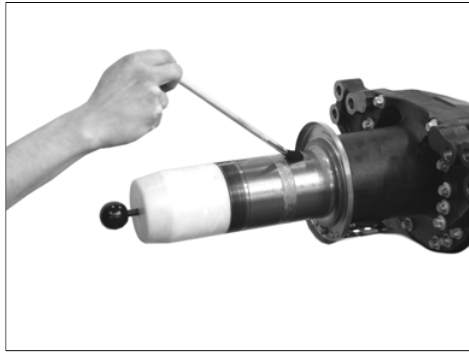

6. Reassembly of hub

Correct procedure for mounting wheel head Inc. Greasing

Insert assembly aid (5870.651.085) in to the hub carrier.

Note: To prevent hydro locking the wheel head at assembly the following procedure must be adhered to.

Over Greasing the axle tube will create this issue!

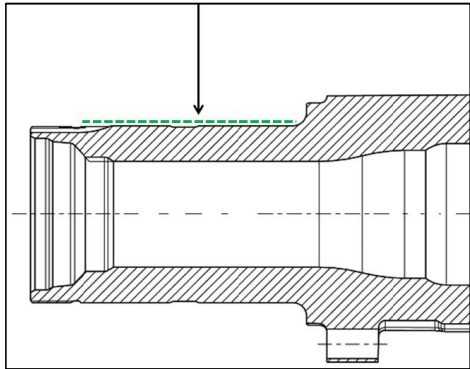

Greasing Procedure

Grease only on the area shown at the point of the arrow.

Note: the grease is used to provide a corrosion resistance coating only.

Grease must conform to the ZF **TE-ML 12** Approved list of lubricants

Do Not Over Grease!!!

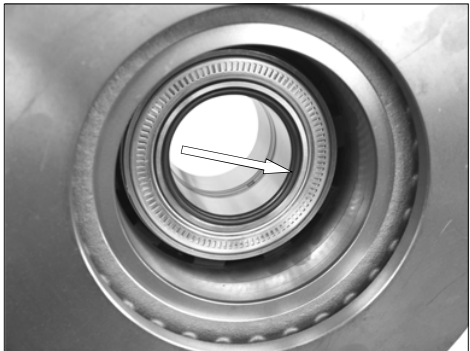

Re-fitting the wheel head.

Remove o'ring from compact bearing annular groove.

Lightly lubricate the O-ring and re- insert it into the annular groove (see arrow). This is the inner side of the rotor.

Note: Try and prevent any grease getting on the rotor, so as not to contaminate the brake pads.



Carefully mount the preassembled hub to the hub carrier using a safe method of working or by means of the load carrying fixture supplied (5870.281.043) until contact is obtained.

Screw on inner slotted nut with the chamfer facing towards you and again using the slotted nut wrench (5870.401.146) Pre-tighten the inner slotted nut to a torque of:
Torque $M_A = 100 \text{ N/m} = 74 \text{ lbf.tf}$

This will effectively push the ABS sensor into the correct position (expect a grinding noise). Rotate the hub several times in each direction and using a rubber mallet strike the rotor every half turn to seat the compact bearing o'ring.



Final torque for inner slotted nut.

Again using the slotted nut wrench (5870.401.146)
Tightening the inner slotted nut to the specified torque:

Torque (Inner Slotted nut) $M_A = 850 \text{ N/m} = 627 \text{ lbf.ft}$

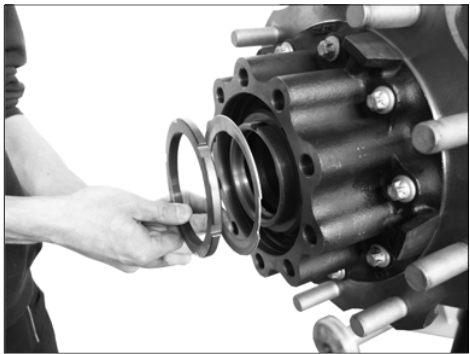

Mount locking plate with the tab facing towards the differential.

With the chamfer also facing towards the differential, screw the outer slotted nut up to the lock plate and torque.

Torque (outer slotted nut) $M_A = 1200 \text{ N/m} = 885 \text{ lbf.ft}$

Note: Ensure correct installation position. Also see legend below for exact slotted nut and lock plate orientation.

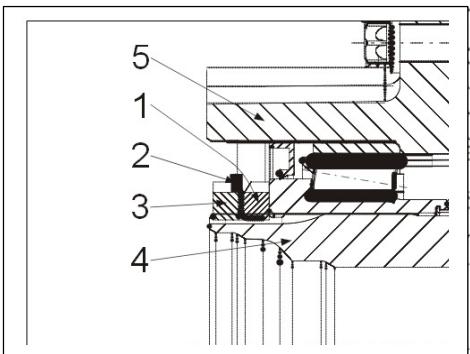

☞ Legend:

- 1 = Inner slotted nut
- 2 = Locking plate
- 3 = Outer slotted nut
- 4 = Hub carrier
- 5 = Hub



Secure slotted nut by Staking the locking plate into any of the slots of the outer slotted nut, taking care not to damage the mating surface of the wheel end, where the flange shaft o'ring is seated!

☞ **Note:** This is absolutely critical and must deform the lock plate enough to stop the outer slotted nut from spinning should the tightening torque be lost!

☞ **Note:** You **MUST** torque seal (shown with red paint) over the outer slotted nut onto the end of the hub casting so that any movement during service can be viewed on inspection.

Lubricate the chamfer on the wheel end to assist the insertion of the flange shaft.



Re-installing the flange shaft.

Lubricate the O-ring (see arrow) and insert it into the annular groove of the flange shaft.

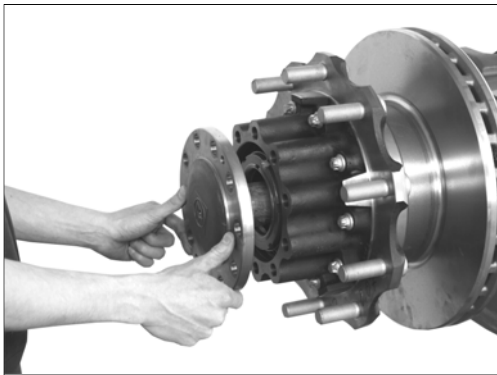

Insert the flange shaft into the hub carrier and gently locate the differential splines.

Push the flange up to the wheel end.

Insert 2 x screws and slowly pull the flange into the wheel head to prevent trapping the o'ring.

Fit remaining screws and torque to:

Tightening torque (M18x1.5) $M_A = 440 \text{ N/m} = 325 \text{ lbf.ft}$

Note:

The brake manufacturer's instructions and specifications are mandatory for any operations done on the brake system!

The relating information is included in the repair, maintenance and service manuals of the component manufacturer!

The applicable instructions are to be requested from the brake manufacturer or can be viewed on the brake manufacturer's website!

Brake manufacturer and brake type are indicated on the identification plate of the brake caliper!

7. Reassemble brake and brake cylinder



Mount brake caliper assembly to axle.

The Fitted screw must be nipped tight before torquing begins.

Tightening torque (M20/12.9) $M_A = 650 \pm 50 \text{ N/m}$
 $= 479 \pm 37 \text{ bf.ft}$

Tightening torque (fitted bolt M20) $M_A = 475 \pm 40 \text{ N/m}$
 $= 350 \pm 30 \text{ lbf.ft}$

Tightening torque (M16x1.5/10.9) $M_A = 270 \text{ N/m}$
 $= 199 \text{ lbf.ft}$

Tightening torque (fit bolt M16x1.5) $M_A = 270 \text{ N/m}$
 $= 199 \text{ lbf.ft}$

Tightening up Caliper carrier bolts

The use of torque adaptors has been recognized as the best method to torque the caliper carrier bolts on certain applications.

Torque conversions must be calculated when extending the length of your torque bar, and torquing should be carried out in one smooth movement without vigorous effort to prevent inaccuracies.

Use this web page for torque calculations:

www.motorcraftservice.com/renderers/torquewrench/wrench_formula_main_en.asp

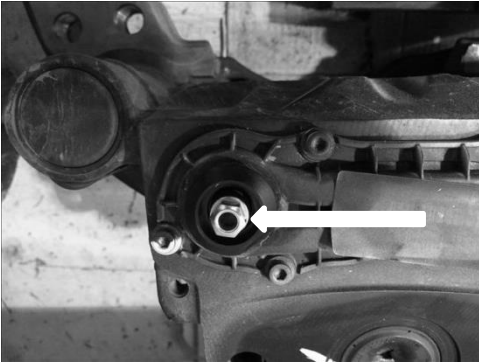

Adjusting the brake using a short 10mm wrench

While spinning the rotor adjust the brake in a clockwise direction until the rotor is no longer able to spin.

Back off adjuster 2 clicks and the clearance is set.

Note: The caliper adjuster incorporates a sintered shear adapter to prevent damage to the adjuster over tightening will cause the adaptor to fail, replacements are available, please leave a functioning adaptor in place.



Refitting the wear indicator

Where relevant refit the connectors to the caliper to prevent electrical errors.

This procedure is the reverse of dis-assembly.

Refit the brake cylinder and torque the 2 x 24mm lock nuts to $M_A = 190 \text{ N/m}$
 $= 140 \text{ lbf.ft}$



Recommendation

The Use lifting cart has been recognized as good method of lifting the parts on and off for safe working practice.



8. Refilling with the saved oil

Take the saved oil in the clean container and refill the axle

Carry out a short test drive and re-check oil level.

If a top up of oil is required only use oils from the **ZF approved list of lubricants TE-ML 12.**

Adjust oil level accordingly

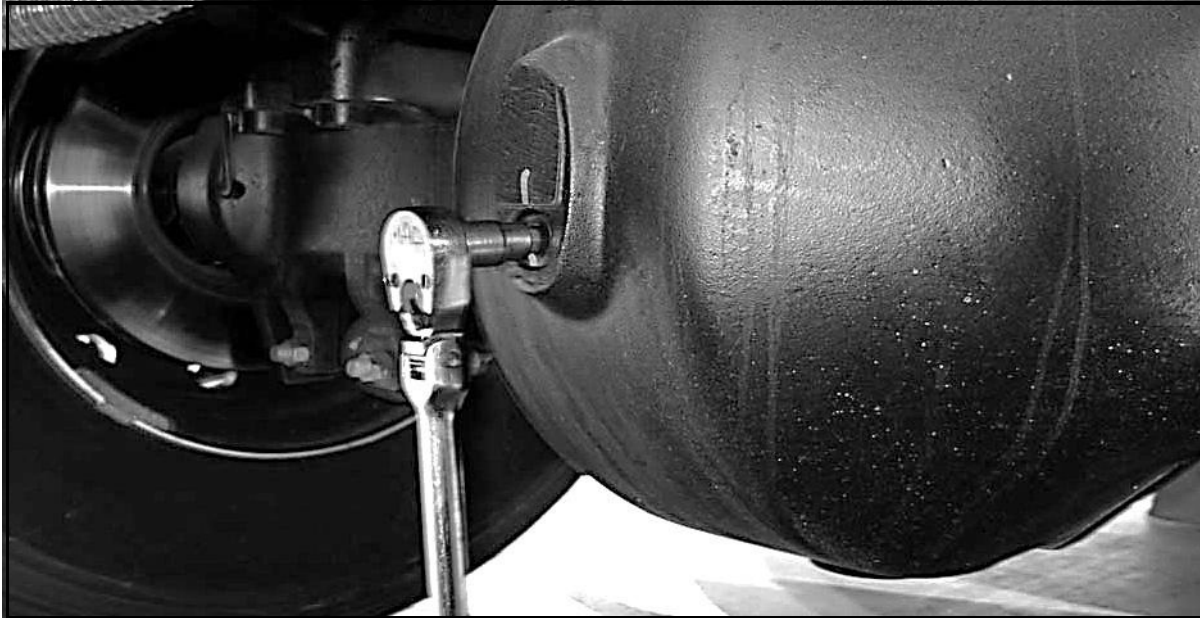

Precondition for a correct oil change is the proper installation of the axle in each direction. Place the vehicle into a horizontal position.

Carefully clean all drain plugs, filler plugs and level check plugs prior to opening.

Only drain oil immediately after a longer operation period.

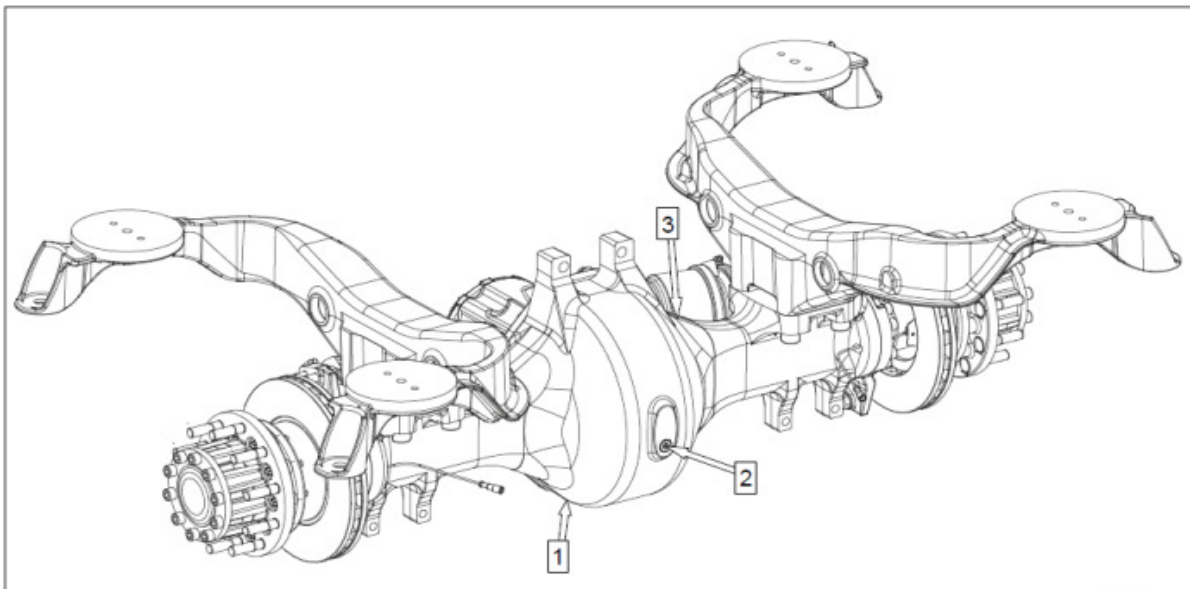

Fig. 1

Legend:

1 = Oil drain hole

M36 x 1.5 Axle housing

Tightening torque

$M_A = 130 \text{ Nm}$

$= 96 \text{ lbf.ft}$

2 = Oil filler hole (oil level)

M24 x 1.5 Axle housing

Tightening torque

$M_A = 70 \text{ Nm}$

$= 52 \text{ lbf.ft}$