



Forest River, Inc.

55470 County Road 1, P.O. Box 3030, Elkhart, Indiana 46515-3030

IMPORTANT SAFETY RECALL

Date: February 16, 2016

Recall Number: NHTSA: 15V798 / CANADA: 2015-581

Article Number: 51-11102015-0109

Dear Valued Forest River - Coachmen Dealer,

Pursuant to USC49CFR §577.13 – Notification to Dealerships and Distributors – Paragraph B

“It is a violation of Federal Law for a dealer to deliver a new motor vehicle or any new or used item of motor vehicle equipment (including a tire) covered by the notification under a sale or lease until the defect or noncompliance is remedied. Substantial civil penalties apply to violations of this law.”

–Forest River motorized and towable products are contained within this section-

Forest River – Office of Corporate Compliance has decided that a defect, which relates to the motor vehicle safety, exists in certain 2007 through 2015 model year Forest River - Coachmen Class “A” and Class “C” recreational vehicles with electric double and triple steps. Forest River - Coachmen is recalling the defect model(s) to ensure the safety of our future retail consumers and your dealership. Forest River apologizes for any inconvenience this action may cause your dealership; however, safety, continued satisfaction and our commitment to build great products are of the utmost importance to Forest River.

The identified VIN numbers are attached to the end of this notification.

The identified Date range of production is: 2007 through 2015

DEFECT/NONCOMPLIANCE:

According to the Part 573 Report filed by Lippert Components, Inc. (Lippert), 15E078, potential structural fracture of the center bolt of the fan gear assembly may cause the fan gear assembly to disengage from the steps.

The step part numbers are; 128980; 64194; 165033; 165034; 165035; 165044; 168367; 171317; 171776; 173476; 234310.

EVALUATION OF RISK:

According to the recall report filed by Lippert Components, Inc., 15E078, if the center bolt of the fan gear assembly fractures, the fan gear assembly may disengage from the steps making the steps unstable, possibly causing a person to fall and resulting in injury.

ACTION:

Please refer to the included documents for remedy:

Coachstep Recall F.A.Q.
Coachstep Double Step Recall Repair Instructions
Coachstep Triple Step Recall Repair Instructions

AVAILABILITY OF REMEDY:

Upon Receipt of this letter.

WHAT IS THE PART NUMBER OF THE REMEDY KIT:

Please refer to the appropriate repair instructions for either the double step or triple step.



Forest River, Inc.

55470 County Road 1, P.O. Box 3030, Elkhart, Indiana 46515-3030

IMPORTANT SAFETY RECALL

Parts Orders:

Any and all order(s) for remedy for the double and triple steps shall be directed to Lippert Components as indicated in the *Coachstep Recall F.A.Q.*

Remedy Kits are noted to be ordered via the Lippert Web Portal:

store.lci1.com/recall-coach-step

Labor Claims:

All labor claims will also be paid for directly to your dealership via Lippert Components. Please refer to the included *Coachstep Recall F.A.Q.*

HELPFULL CONTACT INFORMATION – Lippert Customer Service:

LCI – Customer Service	coachsteprecall@lci1.com	(574) 537-8900
------------------------	--	----------------

The Recall shall be considered priority to remedy the Forest River Class “A” and Class “C” recreational vehicles with electric double and triple steps in question. **The retail consumer shall not be charged** any amount of monies for repair/remedy to their Forest River Class “A” and Class “C” recreational vehicles with electric double and triple steps that are covered under this Recall.

If your dealership has already preformed the repair/remedy to Forest River Class “A” and Class “C” recreational vehicles with electric double and triple steps, your dealership is entitled to the reimbursement as stated above; if the repair/remedy had been performed on an out of warranty Forest River Class “A” and Class “C” recreational vehicles with electric double and triple steps in which the VIN number falls under as stated in the opening paragraph where no warranty claim has/had been filed against the VIN number and the consumer paid for the repair/remedy personally. Please contact your Warranty Manager within Forest River to arrange the reimbursement. Proof of repair/remedy shall be required.

Federal regulation requires that any lessor receiving this Recall must forward a copy of this notice to the lessee within ten days. If your dealership no longer owns this vehicle, please inform the Warranty Manager of the product listed above of the change of ownership.

Sincerely,

Forest River, Inc.
Engineer & Director
Office of Corporate Compliance



LIPPERT
COMPONENTS®

Coachstep Recall Frequently Asked Questions

Q: Is my step involved in the recall?

A: If your RV has a Coachstep electric double step or Coachstep electric triple step produced by Lippert Components from 5-25-2007 thru 12-18-2014 it is included in the recall. Single electric step assemblies and sliding box assemblies are not being recalled. No manual steps are being recalled. You will receive notification from the RV Manufacturer and/or your dealer if your step is included in the recall. Please follow the instructions provided by the RV Manufacturer.

Q: When will repair kits be available for the recall?

A: As of February 1, 2016 there will be limited availability of kits.

Q: How do I have the recall completed?

A: Contact your local dealer and provide them with the notification you received from the RV Manufacturer.

Q: What does the repair kit correct?

A: Each Double Coachstep Repair kit includes the pieces necessary to install a retainer bracket on a Double Coachstep assembly. This will ensure there is not a future issue in the event the center bolt breaks or becomes disengaged.

Each Triple Coachstep Repair kit includes the pieces necessary to install a linkage assembly and a retainer bracket on a Triple Coachstep assembly. This will ensure there is not a future issue in the event the center bolt breaks or becomes disengaged.

Q: What do I do if the center bolt on my step is currently broken?

A: Have a qualified dealer install a replacement center bolt and the required kit specific to Lippert Coachstep electric double or triple steps.

Q: Why is there not a new center bolt included in the repair kit?

A: The installation of the retainer bracket and included components in the repair kit(s) provides the necessary structural and functional support.

Q: Does this recall cover the motor, module, gear plate, other components, rust or other cosmetic concerns?

A: No, the recall is applicable ONLY to the center bolt and installation of the kits listed above. Various components of your steps may require repair or replacement due to normal wear and tear, misuse or abuse.



LIPPERT
COMPONENTS®

Coachstep Recall Frequently Asked Questions (Continued)

Q: Can a retail owner order the parts and complete the recall?

A: No. This recall **MUST** be handled by a qualified dealer or repair facility.

Q: How do I obtain a repair kit?

A: Please follow the instructions provided to you in the recall notification letter from the RV Manufacturer.

The following RV Manufacturers have agreed to allow dealerships to obtain parts directly from Lippert Components via our online store at store.lci1.com/recall-coach-step:

Forest River	Jayco
Coachmen	Tiffin Motorhomes
Gulf Stream Coach	
REV RV Group (including Monaco, Holiday Rambler, Safari, and Beaver products)	

All other RV Manufacturers currently require each dealer/retail owner to contact and obtain parts directly from their Customer Service facility. Please follow the instructions provided to you from the RV Manufacturer.

Q: What if I had my Coachstep electric double or triple steps repaired for the specific issue of the center bolt breaking?

A: If you have repair records and receipts specific to center bolt repairs made within the last 12 months you may be eligible for reimbursement. Please submit this info via e-mail to coachsteprecall@lci1.com. Please ensure full RV identification items are included with your e-mail. The following information will be required: Full 17 digit VIN #, Make/Model, Date of Manufacture of the RV and your Date of Purchase.

Please note prior expenses regarding other components such as a motor, module, gear plate or due to cosmetic issues such as corrosion or rust are not included and would not be subject to potential reimbursement.

Q: What if I would rather replace my Coachstep with a Kwikiee Electric Step sold by Lippert Components?

A: If a customer would like new Kwikiee steps in lieu of the remedy repair, as a customer appreciation measure, Lippert Components will provide a \$200.00 credit and pay 0.5 hour for installation labor to your dealer when they order a Kwikiee step as replacement for a unit involved in this Recall. All orders **MUST** be placed by a dealer and **MUST** be ordered directly from Lippert Components via our online store (store.lci1.com/recall-coach-step) using your specific 17 digit VIN.

Q: How do I access the Lippert Components Online Parts Store?

A: store.lci1.com/recall-coach-step

NOTE: Only one (1) kit or discount will be honored per VIN.



COACHSTEP DOUBLE STEP RECALL REPAIR INSTRUCTIONS

RECALL# 15E-078

LABOR FLAT RATE: 0.3 HOURS

Purpose

The intent of this document is to provide instructions for the installation of the Coachstep retainer bracket on double step assemblies.

Preparation

Tools and Hardware Required

- Cordless or Power Drill or Impact Wrench
- 1/8" Metal Drill Bit
- 5/16" Nut Driver Bit or Socket
- 10mm Wrench or Socket
- 2 x 1/2" Wrench or 1 x 1/2" Wrench and 1 x 1/2" Socket
- Coachstep Double Step Recall Parts Kit - P/N 389761 (Fig. 1)
- Jack Stand

Fig. 1

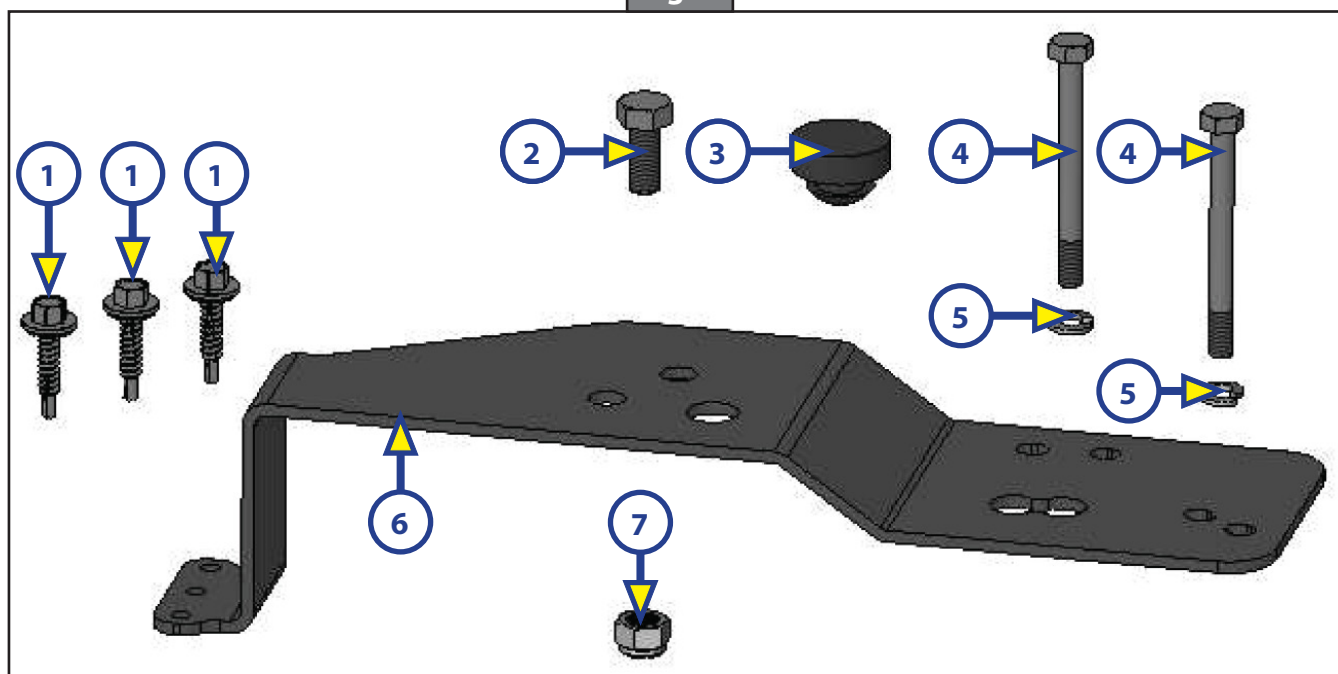

Callout	Part #	Description	Quantity
1	181351	Screw - #12 x 1 Hex Head Washer Tek Screw w/ B/S Washer, Zinc Plated	3
2	125557	Bolt - 5/16 - 18 x 3/4	1
3	163492	Rubber Bumper .70 x 1	1
4	183925	Bolt - 6mm - #10 x 63.5mm Hex Cap Screw GR5 Zinc	2
5	165216	Lock Washer - 6mm Zinc	2
6	386819	Retainer Bracket 11 Gauge	1
7	118043	Nut - 5/16 - 18 Nylock ZN ST	1



COACHSTEP DOUBLE STEP RECALL REPAIR INSTRUCTIONS

1. Fully extend the steps (until the motor stops).
2. Place a jack stand under the bottom step to prevent any potential attempt for automatic retraction.
3. Disconnect the power supply (4-prong connector- Fig. 2A) after extending.

NOTE: Jack stand may be removed once power supply is disconnected.

4. Remove the two motor housing bolts and lock washers (Fig. 3A). The lock washers are shown on the motor housing bolts in the images.

Fig. 2

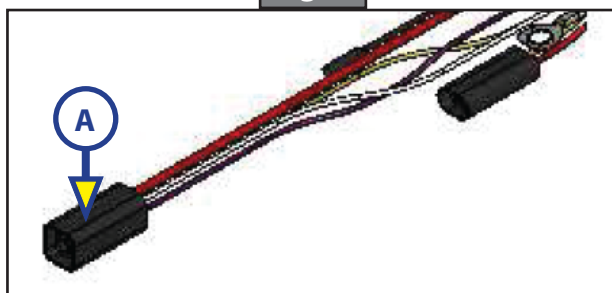

Fig. 3 - Detail

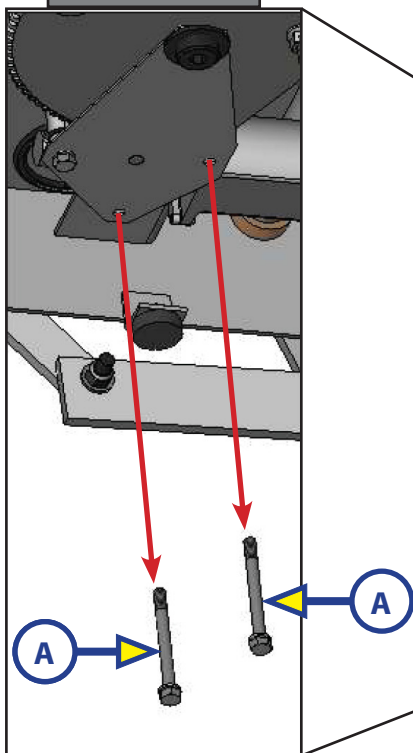
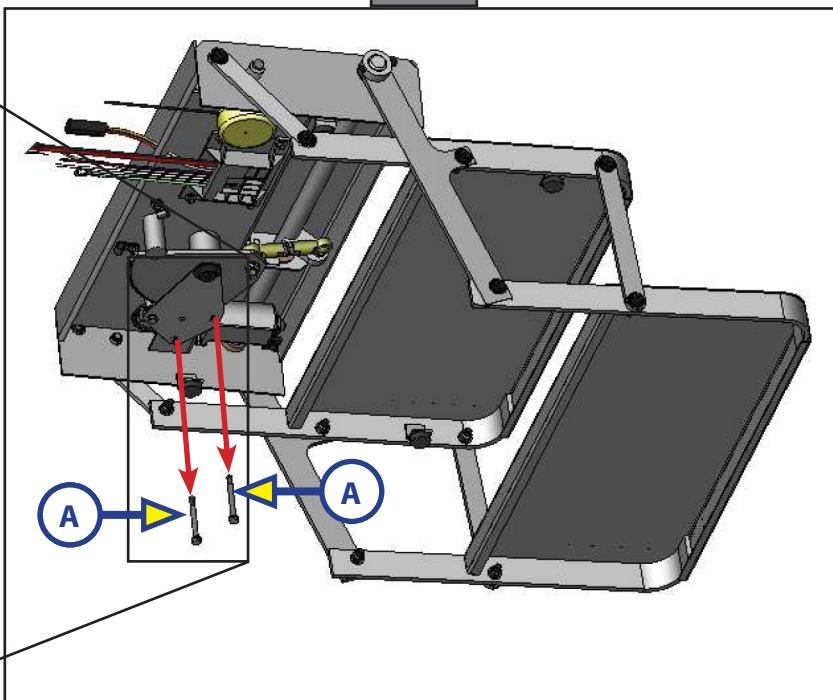

Fig. 3



Procedure

Assembling the Retainer Bracket

1. Install the $\frac{5}{16}$ - 18 x $\frac{3}{4}$ " bolt (Fig. 4A) into the appropriate hole in the retainer bracket (Fig. 4C).
2. Tighten the lock nut (Fig. 4E) onto the bolt (Fig. 4A) until the lock nut contacts the retainer bracket.
3. Install the rubber bumper (Fig. 4B) into the hole in the retainer bracket (Fig. 4D).

Fig. 4

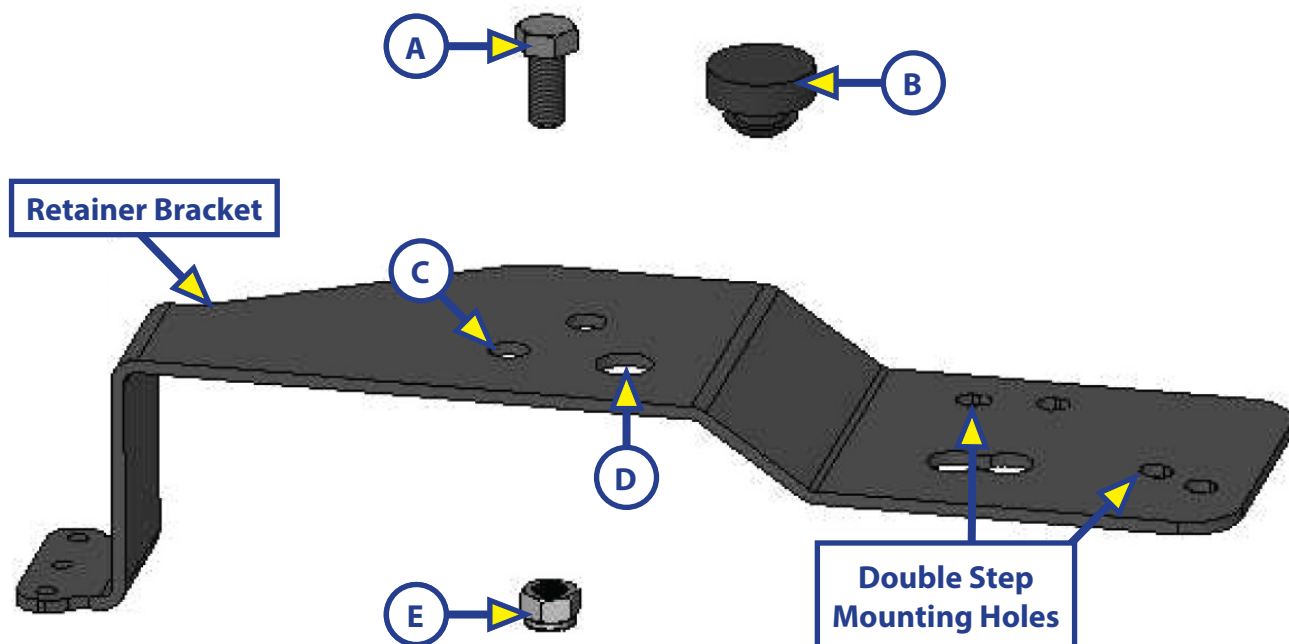

Installing the Retainer Bracket Assembly

1. Clean any dirt or debris from the hex socket on the fan gear shoulder bolt (if necessary) (Fig. 5G).
2. Ensure that all the motor mount spacers (6 total - Fig. 5H) are still in place.
3. Insert the $\frac{5}{16}$ - 18 x $\frac{3}{4}$ " bolt (Fig. 5D) directly into the hex socket of the fan gear shoulder bolt (Fig. 5G).
4. Install the 6mm - 10 x 63.5 mm bolts and 6 mm lock washers (Fig. 5E) through the appropriate mounting holes in the retainer bracket and into the motor housing.

NOTE: If alignment issues for the mounting bolts arise, loosen the lock nut on the $\frac{5}{16}$ - 18 x $\frac{3}{4}$ " bolt (Fig. 5D) to allow the bolt to slide within its oversized hole. Once the mounting bolts are properly aligned, re-tighten the lock nut.

5. Install 3 tek screws (Fig. 5B) through the retainer bracket (Fig. 5C) and control box flange (Fig. 5A), and into the step housing (Fig. 5F) to secure that end of the retainer bracket.

NOTE: Pre-drilling $\frac{1}{8}$ " pilot holes prior to installing the tek screws may help simplify the installation.

6. Tighten the screw until the retainer bracket is flush with the control box flange and the foam washers on the tek screws begin to compress.

NOTE: Be sure to apply proper pressure and drill rotation speed on the drill to avoid stripping the self-drilling threads on the tek screws.

Fig. 5

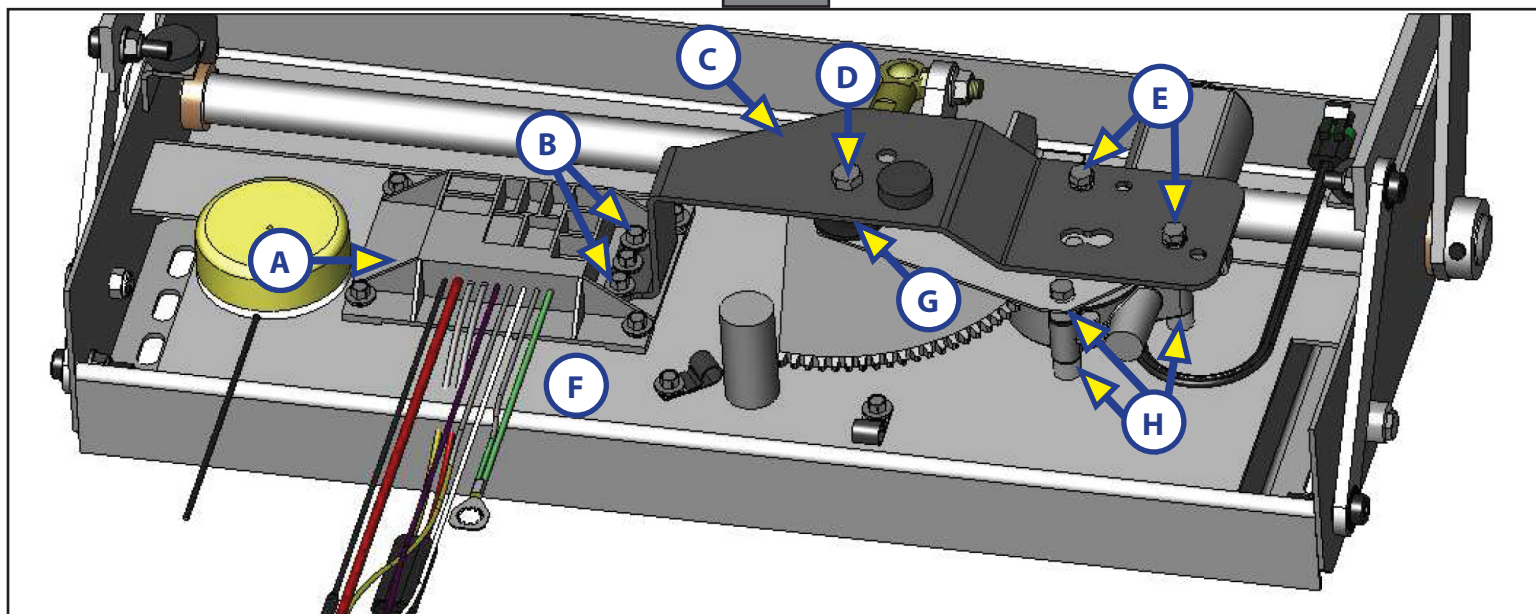

7. Place a jack stand under the bottom step to prevent any potential attempt for automatic retraction.
8. Reconnect the 4-prong connector from the motor control box (Fig. 2A) to the coach power supply.
9. After moving safely away from underneath the motorized steps, remove the jack stand and test the steps for full operation via the standard operation of the coach.



COACHSTEP TRIPLE STEP RECALL REPAIR INSTRUCTIONS

RECALL# 15E-078

LABOR FLAT RATE: 0.5 HOURS

Purpose

The intent of this document is to provide instructions for the replacement of the Coachstep Linkage Assembly and the installation of the Coachstep retainer bracket on triple step assemblies.

Preparation

Tools and Hardware Required

- Cordless or Power Drill or Impact Wrench
- 1/8" Metal Drill Bit
- 5/16" Nut Driver Bit or Socket
- 10mm Wrench or Socket
- Reversing Rocker Switch
- Coachstep Triple Step Recall Parts Kit - P/N 389152 (Figs. 1 & 2)
- Jack Stand
- 12 Volt Power Supply
- 2 x 1/2" Wrench or 1 x 1/2" Wrench and 1 x 1/2" Socket
- 2 x 5/16" Wrench or 1 x 5/16" Wrench and 1 x 5/16" Socket
- Torque Wrench

Fig. 1

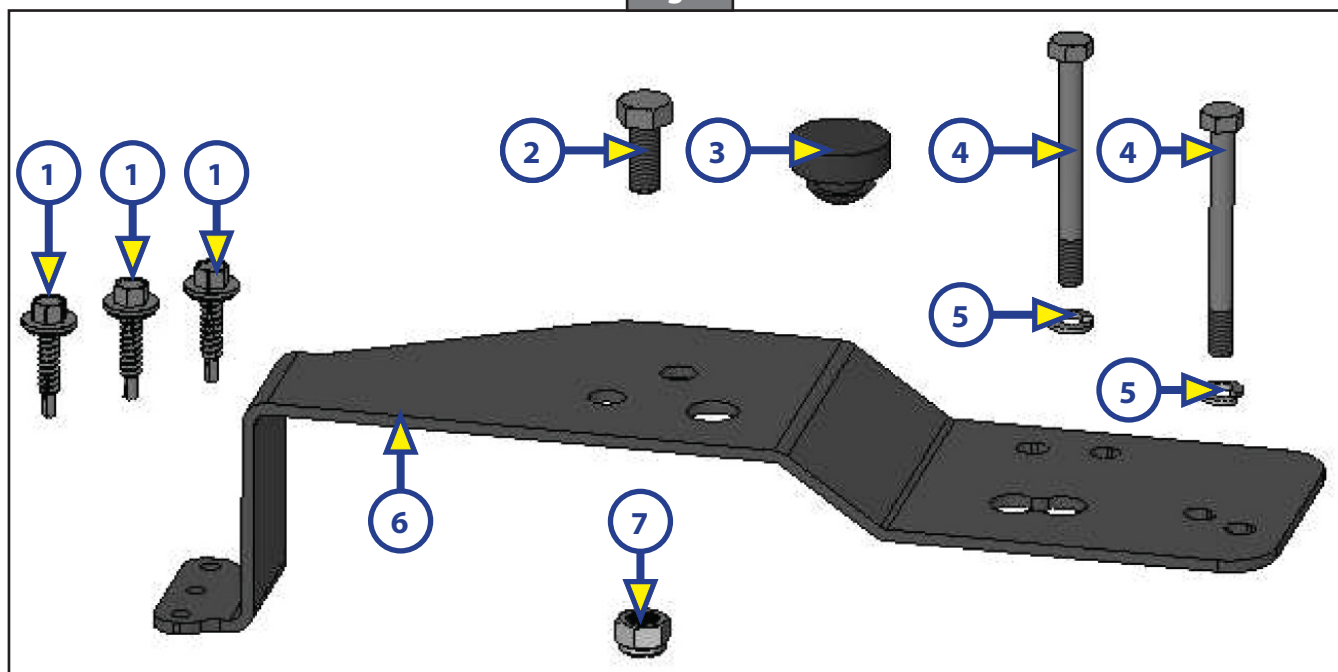

Callout	Part #	Description	Quantity
1	181351	Screw - #12 x 1 Hex Head Washer Tek Screw w/ B/S Washer, Zinc Plated	3
2	125557	Bolt - 5/16 - 18 x 3/4	1
3	163492	Rubber Bumper .70 x 1	1
4	183925	Bolt - 6mm - #10 x 63.5mm Hex Cap Screw GR5 Zinc	2
5	165216	Lock Washer - 6mm Zinc	2
6	386819	Retainer Bracket 11 Gauge	1
7	118043	Nut - 5/16 - 18 Nylock ZN ST	1

Fig. 2

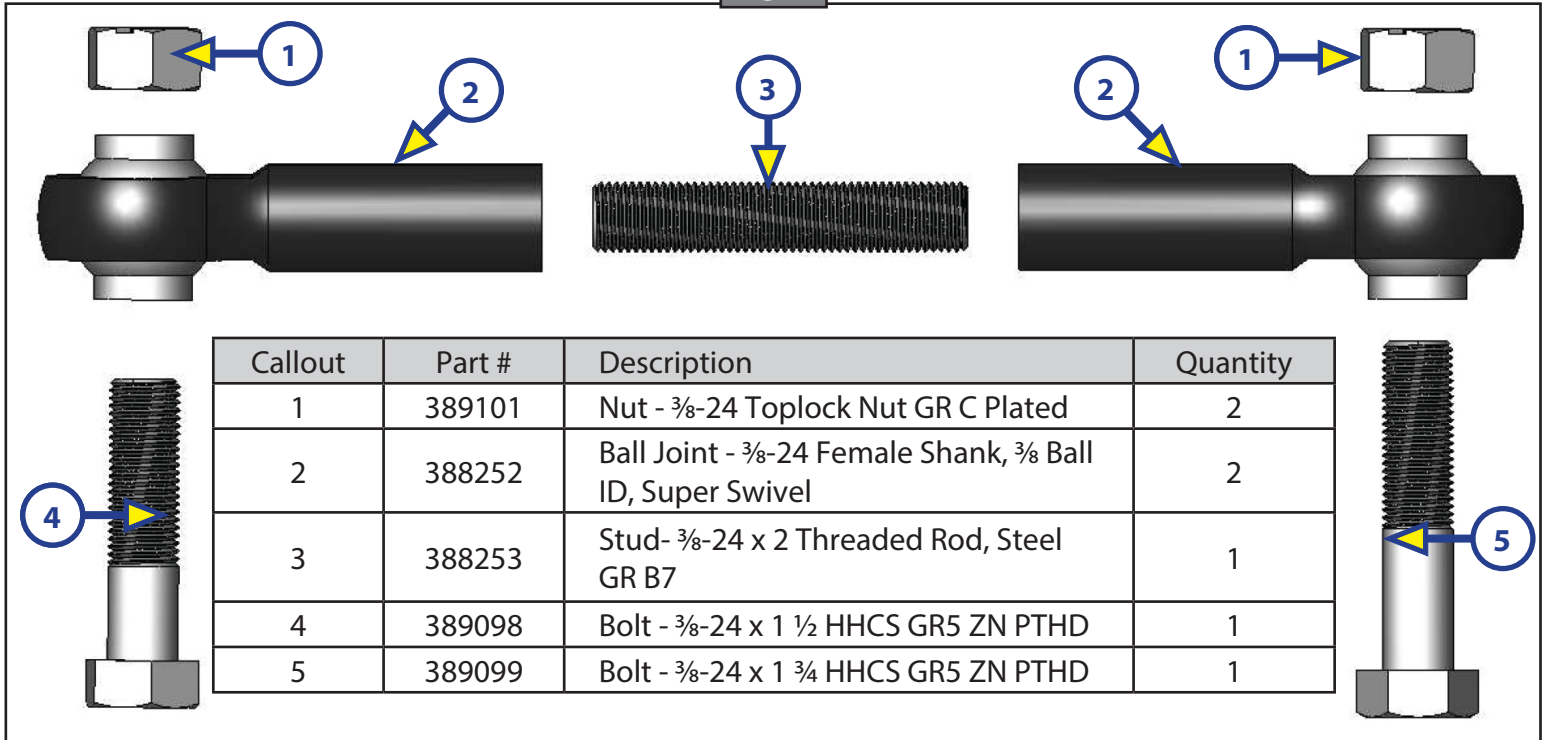

Fig. 3

Linkage Replacement Procedure



1. Fully extend the step (until the motor stops).
2. Disconnect the power supply (4-prong connector) (Fig. 3A) and the motor-to-control connector (2-prong connector) (Fig. 3B) after extending.
3. Position a jack stand (or equivalent support mechanism) under the bottom step so that the extended steps will be supported after the linkage assembly is removed (Fig. 4A).
4. Connect the motor (2-prong male connector) (Fig. 5A) directly to a 12 volt power supply (Fig. 5C) with a reversing rocker switch (Fig. 5B).

Fig. 4

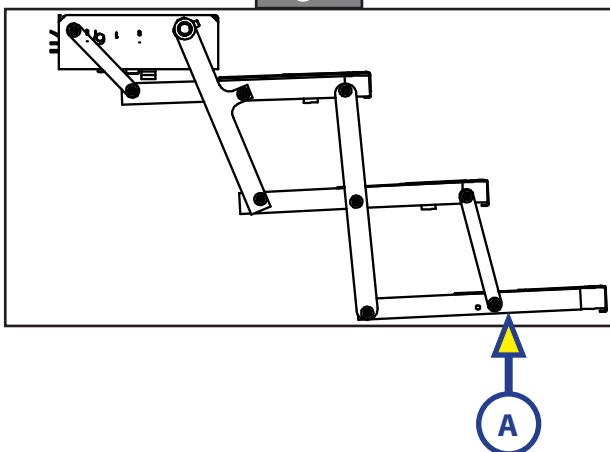
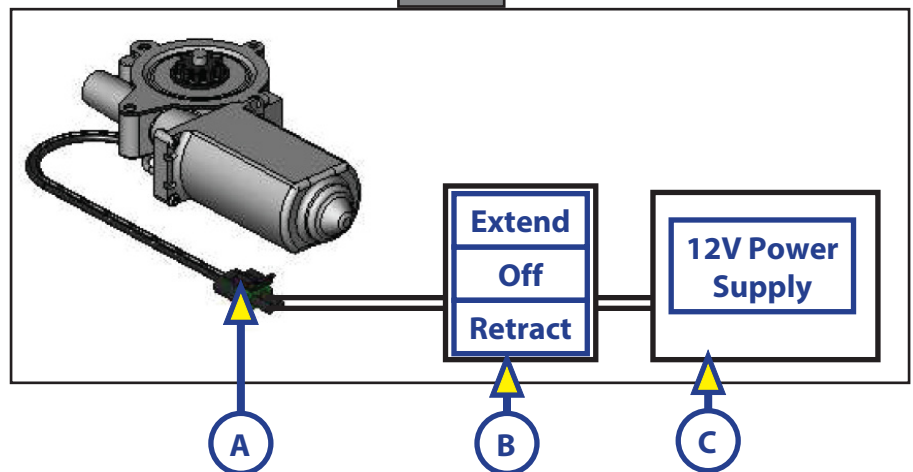

Fig. 5



- Uninstall and remove the linkage assembly (Fig. 6A) using a $\frac{9}{16}$ " wrench or socket and a $\frac{1}{2}$ " wrench.

CAUTION

Ensure that the jack stand(s) is securely placed under the bottom step prior to removing the linkage. The steps will be able to rotate freely after linkage removal which could cause serious personal injury or damage to the coach.

NOTE: If the linkage cannot be fully removed from the assembly, adjust the jack stand(s) to allow a minimal amount of retraction and then extend and retract the motor controls as necessary to help free the linkage.

- Once the linkage is removed, run the motor to full extension.
- Adjust the jack stand(s) if necessary to ensure that the steps remain fully extended until the new linkage is installed.
- Install the new linkage (Fig. 7B) to the fan gear first with a $1\frac{1}{2}$ " bolt (Fig. 7C) and toplock nut (Fig. 7A).

- Adjust the linkage length as necessary until the $1\frac{3}{4}$ " bolt can be inserted through both the linkage end and the shaft leaf. (Fig. 8).

Fig. 6

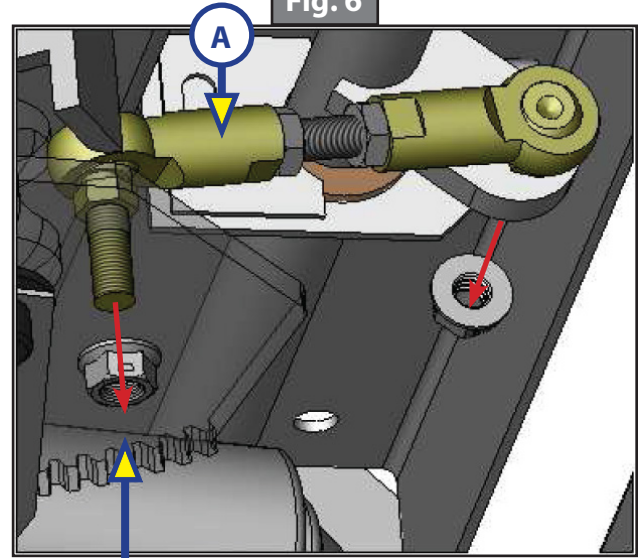

Fan gear shown transparent to show detail.

Fig. 7

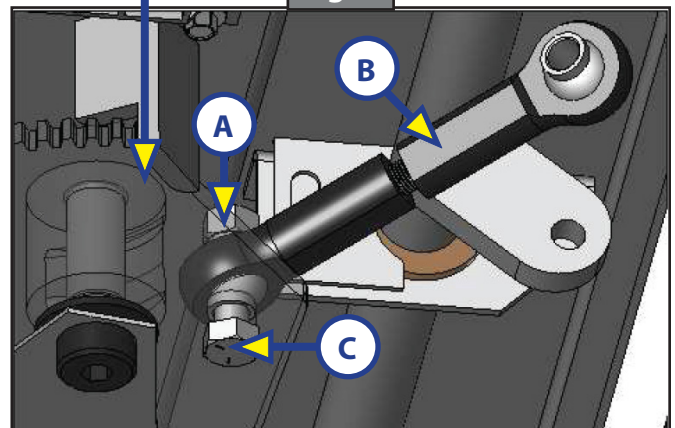
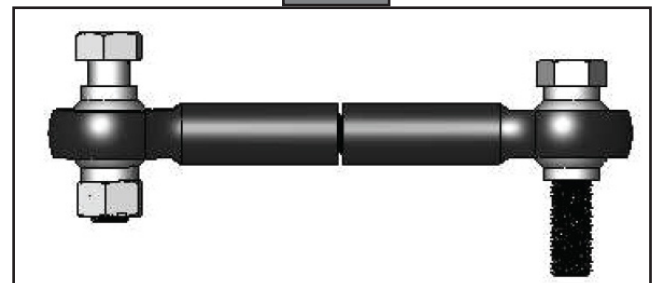

Fig. 8



10. Install the other half of the linkage (Fig. 9A) to the shaft leaf (Fig. 9B) with the 1 3/4" bolt (Fig. 9D) and toplock nut (Fig. 9C).

NOTE: Manually extend or retract the fan gear as needed to align the linkage end with the shaft leaf through-hole. Steps should remain at full extension while supported by the jack stand(s).

11. Tighten the nuts on both linkage ends to 26 ft-lbs of torque.
12. After moving safely away from underneath the motorized steps, remove the jack stand(s) and test the assembly for proper extension and retraction, using the reversing rocker switch. Replace the jack stand(s) under the bottom step once the testing is complete.
13. Disconnect the 2-prong motor connector from the manual 12 volt power supply and reconnect to the motor control box.
14. Reconnect the 4-prong connector from the motor control box to the coach power supply. Ensure that jacks stand(s) is placed appropriately to stop any potential attempt for automatic retraction.
15. After moving safely away from underneath the motorized steps, remove the jack stand(s) and test the steps for full operation via the standard operation of the coach.

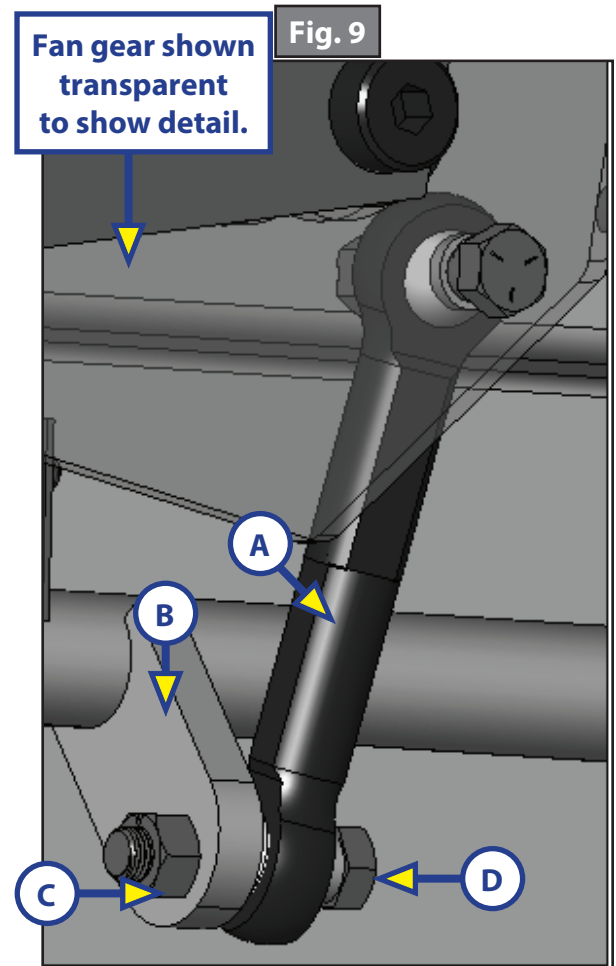

Retainer Bracket Installation

1. Fully extend the steps (until the motor stops).
2. Place a jack stand under the bottom step to prevent any potential attempt for automatic retraction.
3. Disconnect the power supply (4-prong connector- Fig. 10A) after extending.

NOTE: Jack stand may be removed once power supply is disconnected.

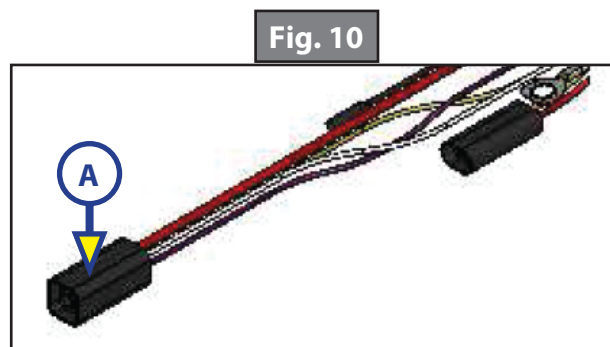

4. Remove the two motor housing bolts and lock washers (Fig. 11A). The lock washers are shown on the motor housing bolts in the images.

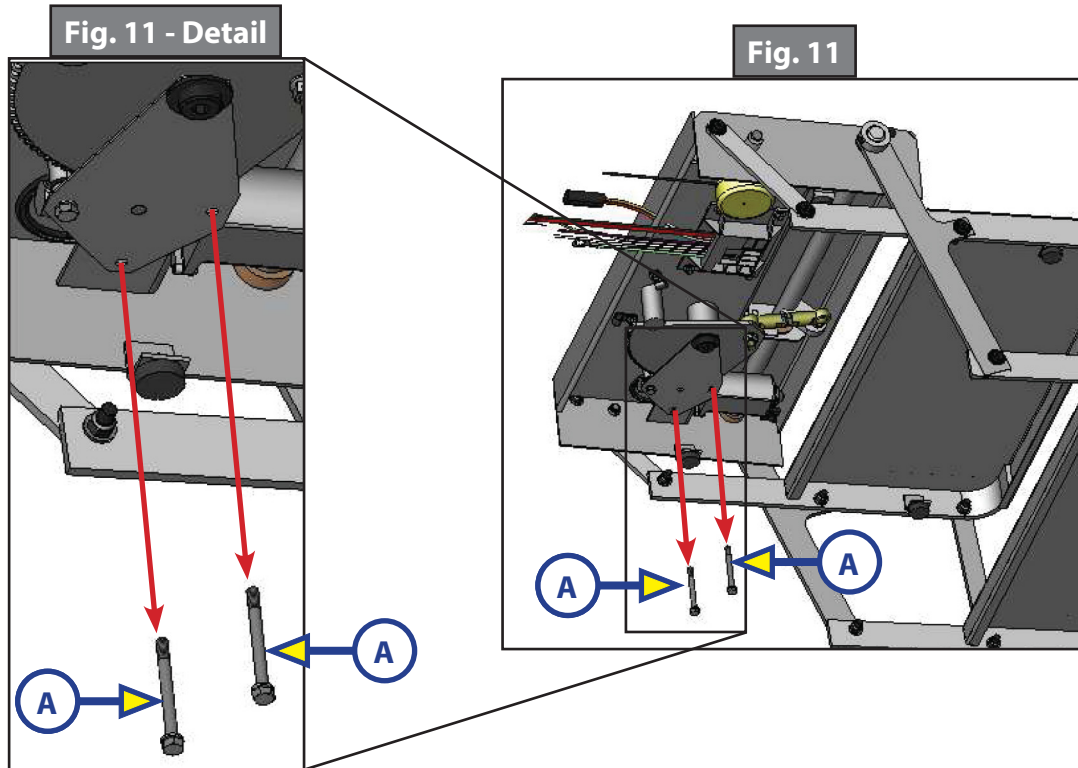

Assembling the Retainer Bracket

1. Install the $\frac{5}{16}$ - 18 x $\frac{3}{4}$ " bolt (Fig. 12A) into the appropriate hole in the retainer bracket (Fig. 12C).
2. Tighten the lock nut (Fig. 12E) onto the bolt (Fig. 12A) until the lock nut contacts the retainer bracket.
3. Install the rubber bumper (Fig. 12B) into the hole in the retainer bracket (Fig. 12D).

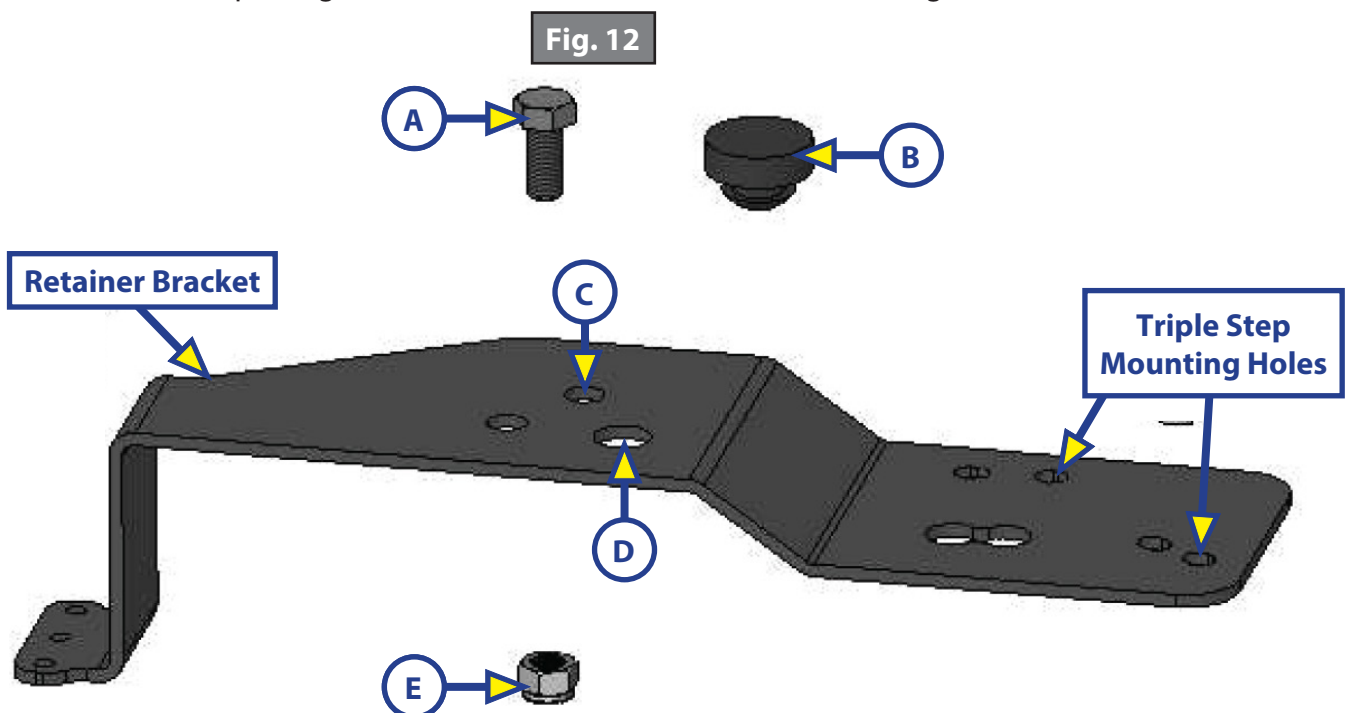

Installing the Retainer Bracket Assembly

1. Clean any dirt or debris from the hex socket on the fan gear shoulder bolt (if necessary) (Fig. 13G).
2. Ensure that all the motor mount spacers (6 total - Fig. 13H) are still in place.
3. Insert the $\frac{5}{16}$ - 18 x $\frac{3}{4}$ " bolt (Fig. 13D) into the hex socket of the fan gear shoulder bolt (Fig. 13G).
4. Install the 6mm - 10 x 63.5 mm bolts and 6 mm lock washers (Fig. 13E) through the appropriate mounting holes in the retainer bracket and into the motor housing.

NOTE: If alignment issues for the mounting bolts arise, loosen the lock nut on the $\frac{5}{16}$ - 18 x $\frac{3}{4}$ " bolt (Fig. 13D) to allow the bolt to slide within its oversized hole. Once the mounting bolts are properly aligned, re-tighten the lock nut.

5. Install 3 tek screws (Fig. 13B) through the retainer bracket (Fig. 13C) and control box flange (Fig. 13A), and into the step housing (Fig. 13F) to secure that end of the retainer bracket.

NOTE: Pre-drilling $\frac{1}{8}$ " pilot holes prior to installing the tek screws may help simplify the installation.

6. Tighten the screw until the retainer bracket is flush with the control box flange and the foam washers on the tek screws begin to compress.

NOTE: Be sure to apply proper pressure and drill rotation speed on the drill to avoid stripping the self-drilling threads on the tek screws.

Fig. 13

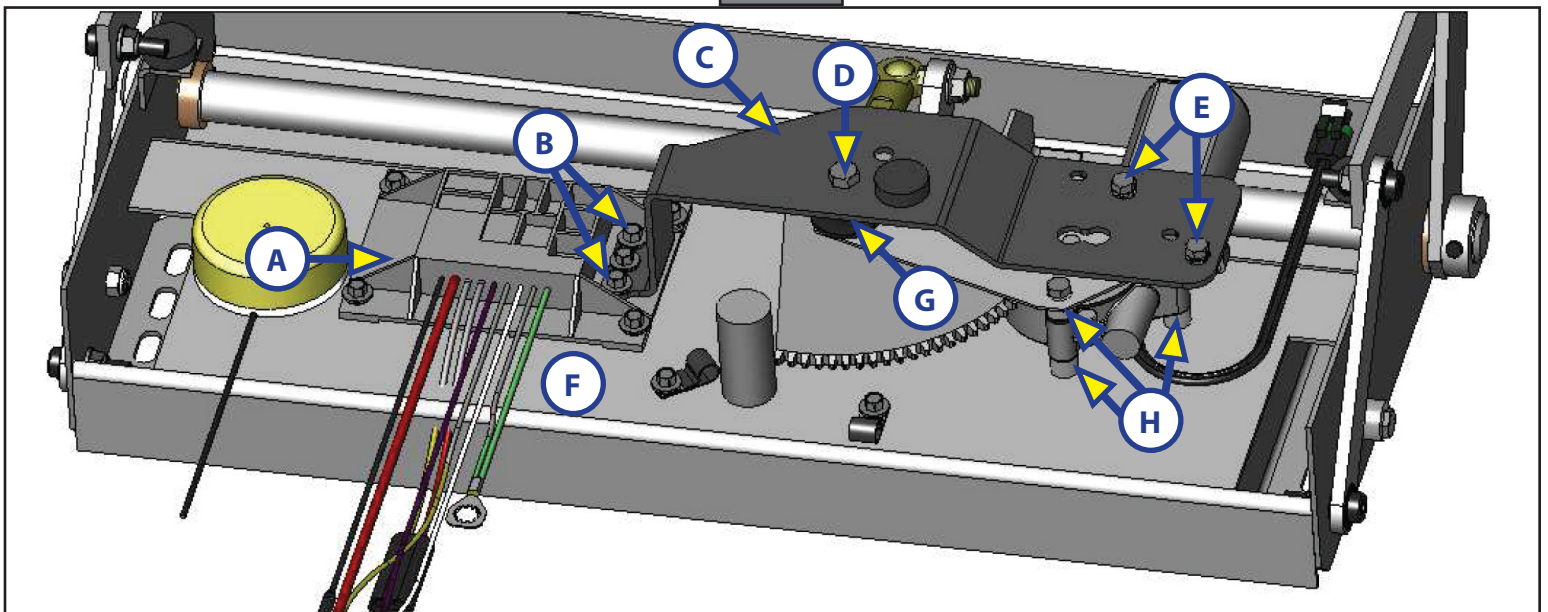

7. Place a jack stand under the bottom step to prevent any potential attempt for automatic retraction.
8. Reconnect the 4-prong connector from the motor control box (Fig. 10A) to the coach power supply. Ensure that jacks stand(s) is placed appropriately to stop any potential attempt for automatic retraction.
9. After moving safely away from underneath the motorized steps, remove the jack stand(s) and test the steps for full operation via the standard operation of the coach.