

TOYOTA

◀ IMPORTANT UPDATE ▶

PRODUCT SUPPORT DIVISION

The attached Technical Instructions and Dealer Letter have been updated. Refer to the details below.

DATE	TOPIC
10/22/14	Part Ordering Section update to clarify correct part for corresponding location
10/27/14	Op. Codes Added
11/13/14	ASM Reference Guide Added and UIO Updated
11/19/14	Hang Tag Part Number Added
01/07/15	2005 Sequoia & Tundra Part Number Added
02/03/15	UIO Updated
02/03/15	2005 Corolla and Corolla Matrix Part Number Added
02/23/15	Airbag Disablement <u>DISCONTINUED</u>
05/13/15	Expansion of Model Years
05/15/15	UIO Updated
06/15/15	High absolute humidity area updated, UIO updated
07/01/15	Update to Rental Information, Warranty Sublet, and Return Parts Shipping
03/01/16	Expanded to include 08MY Corolla and Corolla Matrix
03/10/16	An additional repair procedure to replace the airbag assembly is now available for Corolla Matrix vehicles.
05/09/16	An additional airbag inflator Part Number is now available for 2005-2008 Model Year Corolla vehicles.
08/08/16	<i>An additional airbag inflator Part Number is now available for 2005-2007 Model Year Sequoia and 2005-2006 Tundra vehicles.</i>

The most recent update in the attached Technical Instructions and Dealer Letter will be highlighted with a red box.

Please review this notification with your staff to assure that all relevant personnel have been briefed regarding this subject.

Thank you for your cooperation.

To: All Toyota Dealer Principals, Service Managers, and Parts Managers

Subject: **Safety Recall E04 – For Areas of High Absolute Humidity - UPDATE**
Certain 2003-2008 Model Year Corolla and Corolla Matrix Vehicles
Certain 2003-2006 Model Year Tundra Vehicles
Certain 2002-2007 Model Year Sequoia Vehicles
Front Passenger Airbag Inflator Module

This Safety Recall applies to owners of vehicles originally sold in, or currently/previously registered in, areas of High Absolute Humidity, encompassing the following states: Texas, Alabama, Mississippi, Georgia, South Carolina, Florida, Hawaii, and Louisiana. In addition, it includes Puerto Rico, Guam, Saipan, American Samoa, and the U.S. Virgin Islands.

Background

In mid-October, 2014, Toyota filed a Defect Information Report (DIR) with the National Highway Traffic Safety Administration (NHTSA) informing the agency of our intent to conduct a voluntary Safety Recall on certain 2003-2005 model year Corolla, Corolla Matrix, and Tundra vehicles and certain 2002-2005 model year Sequoia vehicles.

- In mid-May, 2015, Toyota expanded Safety Recall E04 to include additional 2005-2007 model year Corolla, Corolla Matrix, Sequoia, and 2005-2006 model year Tundra vehicles.
- In mid-June, 2015, Toyota expanded Safety Recall E04 to include additional 2003-2007 model year Corolla and Corolla Matrix, 2003-2006 model year Tundra, and 2002-2007 model year Sequoia vehicles. The high absolute humidity area is no longer limited to coastal areas of the specific states listed, and also now includes the state of South Carolina.

Condition

The subject vehicles are equipped with front passenger airbag inflators which may have been manufactured in such a way as to have a potential for the intrusion of moisture over time. Depending on the circumstances, this could create excessive internal pressure when the airbag is deployed and cause the inflator to rupture. In the event of an inflator rupture, metal fragments could pass through the airbag cushion material, striking the vehicle occupants and potentially resulting in serious injury or death.

Remedy

Dealers are requested to replace the front passenger airbag inflator at **no charge** to the vehicle owner. (For certain models, the front passenger airbag assembly may be replaced.)

The following information is provided to inform you of the owner notification timing and your degree of involvement.

1. Owner Letter Mailing

Toyota notified all owners of vehicles covered by the original Safety Recall vehicle population, by first class mail, beginning in late October, 2014, and owners covered by the May 2015 expansion beginning early July, 2015. Owners of vehicles covered by the March 2016 expansion were notified beginning in mid-March, 2016. The owner letter notifications for these customers has been completed.

Toyota tries very hard to obtain current customer name and address information when mailing owner letters. In the event your dealership receives a notice for a vehicle that was sold prior to the Safety Recall announcement, it is the dealership’s responsibility to forward the owner letter to the customer who purchased the vehicle.

If a dealer is contacted by an owner who has not yet received the notification, please **verify coverage by confirming through TIS**. Dealers should perform the procedure as outlined in the Technical Instructions located on TIS.

2. Pre-Owned Vehicles in Dealer Stock

All vehicles in dealership stock that are covered by this Safety Recall must have the passenger airbag inflator replaced before customer delivery.

3. Number and Identification of Covered Vehicles

There are approximately 1,017,000 Toyota vehicles covered by this Safety Recall. Many of the vehicles covered by this Safety Recall were previously part of Safety Recall DSF or Limited Regional Safety Recall E0V.



Model	Model Year	Appx. UIO	Production Range
Corolla	2003 – 2008	622,000	Late December, 2001 - Late December, 2007
Corolla Matrix	2003 – 2008	96,000	Early January, 2002 - Mid-December, 2007
Tundra	2003 – 2006	106,000	Late July, 2002 - Late December, 2006
Sequoia	2002 – 2007	193,000	Early April, 2002 - Late November, 2007

If a dealer is contacted by an owner who has not yet received the notification, please **verify coverage by confirming through TIS**. Dealers should perform the procedure as outlined in the Technical Instructions located on TIS.

4. Campaign Special Service Tools

Dealerships will need to utilize the Special Service Tools provided for Safety Recall D0F. The special service tools were previously sent to your dealership on July 31, 2013.

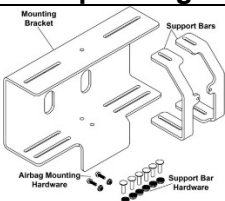
These tools are needed when performing the front passenger airbag inflator module campaign. These tools **ARE NOT** available through normal parts or tools channels. There is a limited supply of tools, but if additional tools are needed, contact your regional representative.

Name	Sample Image	Qty
Airbag Mounting Bracket & hardware		1
Barcode Scanner		1

5. Technician Training Requirements

The repair quality of covered vehicles is extremely important to Toyota. All dealership technicians performing this repair are required to successfully complete the most current version of the E-Learning course “Safety Recall and Service Campaign Essentials”. To ensure that all vehicles have the repair performed correctly; technicians performing this repair must also complete **SC13B** and be certified to one or more of the following levels:

- **Toyota Expert - Electrical**
- **Master Technician**
- **Master Diagnostic Technician (MDT)**

It is the dealership’s responsibility to select technicians with the above certification level or greater to perform this Safety Recall repair. Carefully review your resources, the technician skill level, and ability before assigning technicians to this repair. It is important to consider technician days off and vacation schedules to ensure there are properly trained technicians available to perform this repair at all times.

6. Campaign Specific Part Associate E- Learning Training Requirement

The airbag inflator assembly being replaced during this campaign is a Class 9 Hazmat part. Therefore Parts Associates involved in this recall are required to complete E-Learning Module (**E2140** “*Safety Recall DOF – Front Passenger Airbag Inflator*” found on www.uotdealer.com) This E-Learning module will explain the proper procedure for documenting and returning the airbag inflator assembly to TK Holdings Incorporated.

7. Shipping Information for Removed Inflators and Airbag Assemblies

***Important:** For the Continental 48 states, airbag assemblies are now included in the return shipping process. Refer to the updated Shipment Preparation Job Aid on TIS.
Updated: 3/10/2016*

New Parts Return Shipping Process – Effective July 1, 2015

NOTE: This updated inflator recovery program only applies to the Continental 48 States. Alaska, Hawaii and the US Territories will continue to use the current program.

IMPORTANT: Effective July 1, 2015, the current inflator part return process, **using Fed-Ex as the shipper will be discontinued.** A procedure has been developed by Takata. This part return procedure also includes removed airbag assembly. With this process, each dealer will be required to perform the following:

- Apply a return address label to the outside of each returned airbag/inflator box (**Label provided by Takata in the new part box**).
- Store the old inflators on a pallet until they accumulate 100 inflators/airbag assemblies or whatever amount is collected after 30 days.
- **Keep a running log of how many of each type (Driver or Passenger) inflators and airbag assemblies are on the pallet.**
- Secure the inflators on the pallet with shrink wrap.
- Contact Takata at 1-877-650-9409 to arrange LTL pick-up.
- Place an over-pack label on the palletized load and provide the LTL driver with the pre-filled out documentation that will be sent to the dealer by Takata.

The process will not require the dealer to fill out any paperwork. All documents will be filled out by Takata and returned to the dealer.

Starting June 2015, during part production, Takata started replacing the current FedEx documentation in the airbag/inflator box with the new return labels and updated instructions. To support this new process, in late June 2015, each dealer will receive:

- 4 laminated Job Aids to help you understand the new process.
- 1 roll (125) of the new return labels to use until the new inflators start to arrive with the correct labels in the box. More labels will be available from Takata if needed.

Refer to the Job Aid available on TIS for more details on the new process and how to get more labels.

In addition, to compensate dealers for purchasing pallets and shrink wrap, a sublet claim of 0.20 cents per vehicle may be applied to each inflator replacement warranty claim starting July 1, 2015.

8. Parts Ordering Process

An additional airbag inflator Part Number is now available for 2005-2007 Model Year Sequoia and 2005-2006 Tundra vehicles.

Updated: 08/08/2016

Non SET and GST Parts Ordering Process

Due to limited availability, the parts have been placed on either Manual Allocation Control (MAC) or Dealer Ordering Solutions (DOS). As the parts inventory improves, the ordering process may change. Please check the Toyota Special Activities MAC/DOS report on Dealer Daily for the most up-to-date parts ordering information.

Model	Model Year	Location	Part Number	Part Description	Qty.
Corolla Matrix	2003-2004	48 States in Continental U.S.	04003-28101	INFLATOR ASSY KIT, INSTR PNL AIRBAG	1
		USTT, Hawaii & AK	04003-11101	INFLATOR ASSY KIT, INSTR PNL AIRBAG	1
	2005-2008	48 States in Continental U.S.	04004-75201	INFLATOR ASSY KIT, INSTR PNL AIRBAG	1
		USTT, Hawaii & AK	04004-75101	INFLATOR ASSY KIT, INSTR PNL AIRBAG	1
Corolla	2003-2004	48 States in Continental U.S.	04003-28102	INFLATOR ASSY KIT, INSTR PNL AIRBAG	1
		USTT, Hawaii & AK	04003-11102	INFLATOR ASSY KIT, INSTR PNL AIRBAG	1
	2005-2008	48 States in Continental U.S.	04004-75202 Or 04006-06102	INFLATOR ASSY KIT, INSTR PNL AIRBAG	1
		USTT, Hawaii & AK	04004-75102 Or 04006-06102	INFLATOR ASSY KIT, INSTR PNL AIRBAG	1

(More)

Non SET and GST Parts Ordering Process (Cont'd)

Model	Model Year	Location	Part Number	Part Description	Qty.
Sequoia	2002-2004	48 States in Continental U.S.	04003-2810C	INFLATOR ASSY KIT, INSTR PNL AIRBAG	1
		USTT, Hawaii & AK	04003-1110C	INFLATOR ASSY KIT, INSTR PNL AIRBAG	1
	2005-2007	48 States in Continental U.S.	04004-7520C Or 04006-0620C	INFLATOR ASSY KIT, INSTR PNL AIRBAG	1
		USTT, Hawaii & AK	04004-7510C Or 04006-0620C	INFLATOR ASSY KIT, INSTR PNL AIRBAG	1
Tundra	2003-2004	48 States in Continental U.S.	04003-2810C	INFLATOR ASSY KIT, INSTR PNL AIRBAG	1
		USTT, Hawaii & AK	04003-1110C	INFLATOR ASSY KIT, INSTR PNL AIRBAG	1
	2005-2006	48 States in Continental U.S.	04004-7520C Or 04006-0620C	INFLATOR ASSY KIT, INSTR PNL AIRBAG	1
		USTT, Hawaii & AK	04004-7510C Or 04006-0620C	INFLATOR ASSY KIT, INSTR PNL AIRBAG	1

Important Note: The current airbag inflators for 2005-2007 Model Year Sequoia and 2005-2006 MY Tundra vehicles, part numbers 04004-7520C and 04004-7510C, are still available. **Please continue to order and utilize these Airbag Inflators until your facing PDC and dealer inventory is out of stock.** Orders placed for 04004-7520C or 04004-7510C will substitute to 04006-0620C once inventory at your facing PDC has been depleted.

An additional repair procedure to replace the airbag assembly is now available for Corolla Matrix vehicles.

Important Note: The current repair to replace the inflator is still available. If the vehicle is repaired with an airbag assembly and connector listed below, the inflator DOES NOT need to be replaced.

Model	Model Year	Location	Part Number	Part Description	Qty.
Corolla Matrix	2003-2004	48 States in Continental U.S.	04005-22601	AIRBAG ASSEMBLY W/ INFLATOR	1
		USTT, Hawaii & AK	04005-22501	AIRBAG ASSEMBLY W/ INFLATOR	1
	2005-2008	48 States in Continental U.S.	04005-22901	AIRBAG ASSEMBLY W/ INFLATOR	1
		USTT, Hawaii & AK	04005-22801	AIRBAG ASSEMBLY W/ INFLATOR	1
- AND -					
Corolla Matrix	ALL	ALL	04005-28112	AIRBAG CONNECTOR	1

In the limited cases, where the serial number is illegible, the Airbag Assembly will require replacement. Please contact your regional representative for further direction on vehicle repair and claim filing procedures.

IMPORTANT PARTS ORDERING UPDATE

All Safety Recall, Service Campaign (SSC/LSC) and Customer Support Program (CSP) parts are eligible for the Monthly Parts Return Program. Please refer to PANT Bulletin 2011-087 for campaign parts that are currently returnable under the Monthly Parts Return Program and additional details.

9. Remedy Procedures

Please refer to TIS for Technical Instructions on inspection and repair.

Conduct all applicable, non-completed Safety Recall and Service Campaigns on the vehicle during the time of appointment.

10. Warranty Reimbursement Procedure

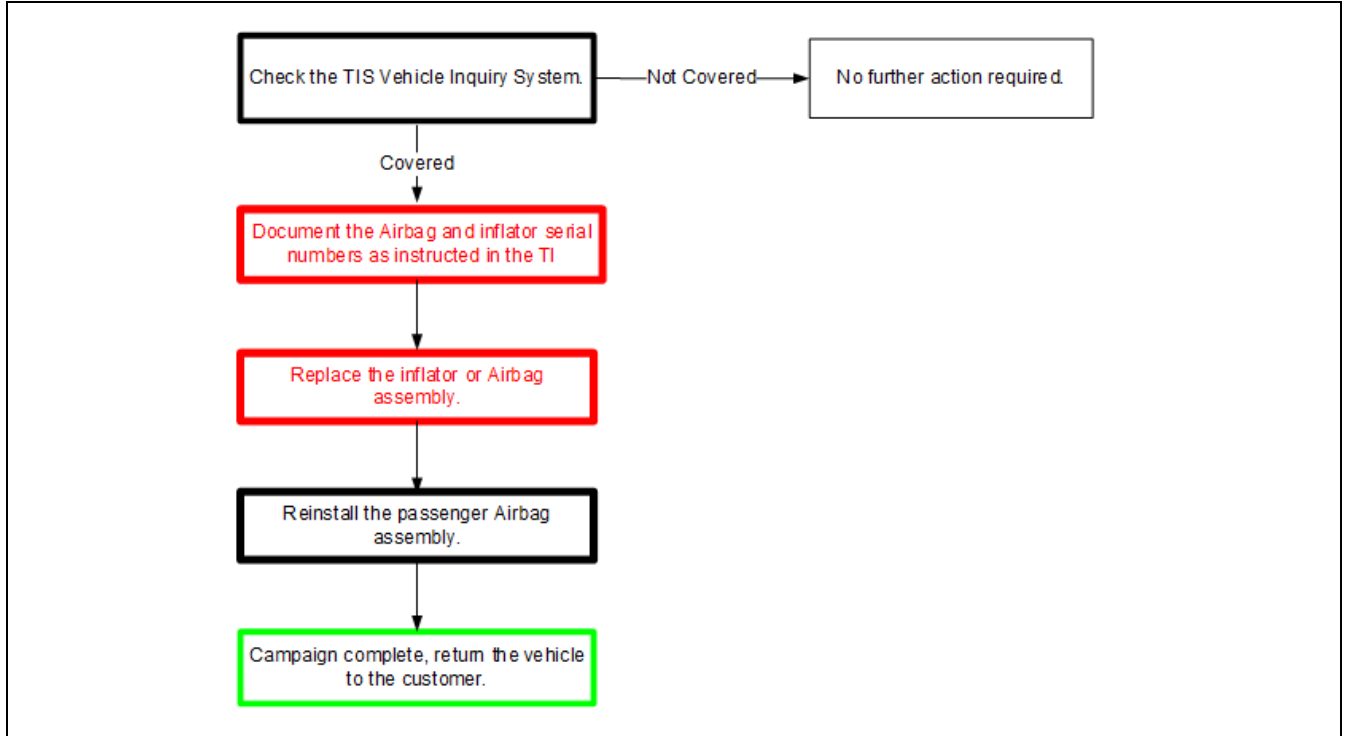

Model	Op. Code	Description	Flat Rate Hour
Tundra & Sequoia	AGGC7B	Replace Airbag Inflator	1.2 hr/vehicle
Corolla	AGGC7G	Replace Airbag Inflator	0.9 hr/vehicle
Matrix		Replace Airbag Assembly or Inflator	

- The flat rate times include 0.1 hours for administrative cost per unit for the dealership.
- Dealers may claim the cost for materials needed for inflator return shipping under opcodes AGGC7B and AGGC7G at a maximum rate of \$0.20 per vehicle as sublet type “ZZ.”
- If parts are not available due to back order, a loaner vehicle or alternative transportation through the Toyota Rent-A-CAR (TRAC) can be claimed for \$35 per day for a maximum of 4 days under sublet type “RT.” Per day expense exceeding \$35 or loaners exceeding 4 days, requires DSPM authorization. For additional information, reference the Toyota Transportation Assistance Program (TTAP) guidelines.
- Towing can be claimed under Op. Code AGGC7B, AGGC7G, and AGGC7W for a maximum of \$250 as sublet type “TW” in the event the customer requested vehicle pick up

In limited instances, a Sequoia vehicle may have an inflator utilizing a large retaining hex nut on the right side. These vehicles are not involved in this Safety Recall. **Refer to the Sequoia Technical Instructions Section VIII-2 for additional details.**

Model	Op. Code	Description	Flat Rate Hour
Sequoia (ONLY)	AGGC7W	Large Retaining Hex Nut Found Vehicle not Involved Under this Safety Recall (Refer to the Sequoia Technical Instructions Section VIII-2)	0.3 hr/vehicle

11. Campaign Designation Decoder

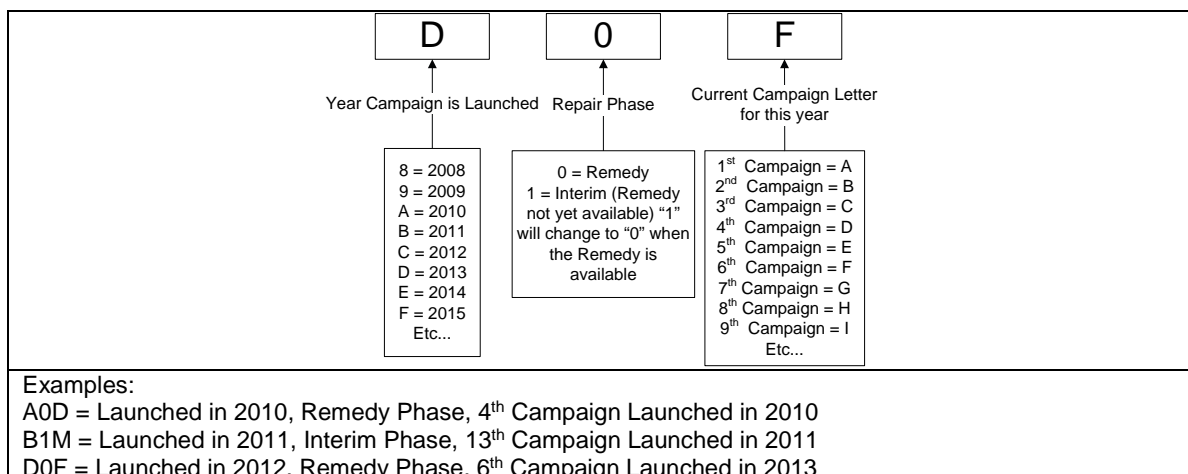

12. Repair Quality Confirmation

The repair quality of covered vehicles is extremely important to Toyota. To help ensure that all vehicles have the repair performed correctly, please designate at least one associate (someone other than the individual who performed the repair) to verify the repair quality of every vehicle prior to customer delivery.

13. Media Contacts

If you are a dealership associate and have any questions, please contact your District Service/Parts Manager. ***In the event you are contacted by the News media***, it is imperative that all media contacts (local and national) receive a consistent message. In this regard, all media contacts must be directed to Cindy Knight, (310) 468-2170 in Toyota Corporate Communications. (Please do not provide this number to customers.)

14. Customer Contacts

A FAQ is attached to help respond to any customer concerns. If the customer has any further questions, they are requested to contact the Toyota Customer Experience Center. The Toyota Customer Experience Center can be reached at 1-888-270-9371 Monday through Friday, 5:00 am to 6:00 pm, or Saturday 7:00 am to 4:00 pm Pacific Time.

Please note the attached FAQ is published on the www.Toyota.com website for customer viewing.

Please review this entire package with your Service and Parts staff to familiarize them with the proper step-by-step procedures required to implement this Safety Recall.

Thank you for your cooperation.
TOYOTA MOTOR SALES, U.S.A., INC.



Safety Recall DSF/E04 - Supplemental ASM Reference
Certain 2003-2008 Model Year Corolla and Corolla Matrix Vehicles
Certain 2003-2006 Model Year Tundra Vehicles
Certain 2002-2007 Model Year Sequoia Vehicles
Front Passenger Airbag Inflator Module



The following information is being provided to help dealership associates understand the differences between the multiple Takata actions Toyota has announced.

Safety Recall Overview:

In April, 2013, Toyota announced a nationwide Safety Recall (D0F) to inspect and, as necessary, replace front passenger airbag inflator modules manufactured for Toyota by Takata Corporation. In June, 2014, the recall remedy was revised to replace all inflators regardless of inspection results. The revision of the remedy was announced as a new Safety Recall DSF. All vehicles that did not receive a replacement inflator under D0F were included in DSF.

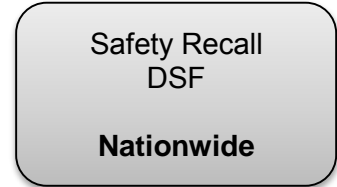

The geographic concentration of inflators with a higher risk of rupture in areas with consistently high absolute humidity warranted priority replacement in these areas. Therefore, Toyota has launched Safety Recall E04 which involves vehicles originally sold in, or currently/previously registered in, areas that are exposed to consistent High Absolute Humidity. These vehicles were previously included in Safety Recalls D0F/DSF and E0V.

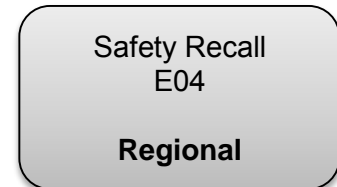

In May, 2015, Toyota expanded Safety Recalls DSF and E04 to include additional vehicles.

- DSF expansion included certain 2003-2004 model year Tundra vehicles and 2004 model year Sequoia vehicles.
- E04 expansion included additional 2005-2007 model year Corolla, Corolla Matrix, Sequoia, and 2005-2006 model year Tundra vehicles.

Updated 5/12/2015

In June, 2015, Toyota expanded Safety Recalls DSF and E04 to include additional vehicles.

- DSF expansion included certain 2005-2007 model year Corolla, Corolla Matrix, Sequoia, and 2005-2006 model year Tundra vehicles.
- For E04, the high absolute humidity area is no longer limited to coastal areas of the specific states listed, and also now includes the state of South Carolina.

Updated 6/15/2015

In March, 2016, Toyota expanded Safety Recalls DSF and E04 to include 2008 model year Corolla and Corolla Matrix vehicles.

Updated 3/1/2016

Safety Recall DSF:

- 2003-2008 Corolla
- 2003-2008 Corolla Matrix
- 2003-2006 Tundra
- 2002-2007 Sequoia

Safety Recall E04:

- 2003-2008 Corolla
- 2003-2008 Corolla Matrix
- 2003-2006 Tundra
- 2002-2007 Sequoia

The map below provides a visual representation of the areas which have been included in Superseding Safety Recall E04 (Red Area). The yellow portion of the map represents an approximate geographic representation of vehicles covered by Safety Recall DSF.

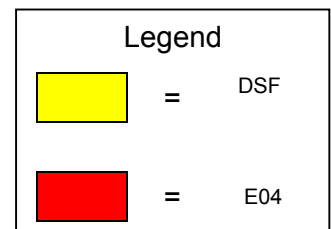
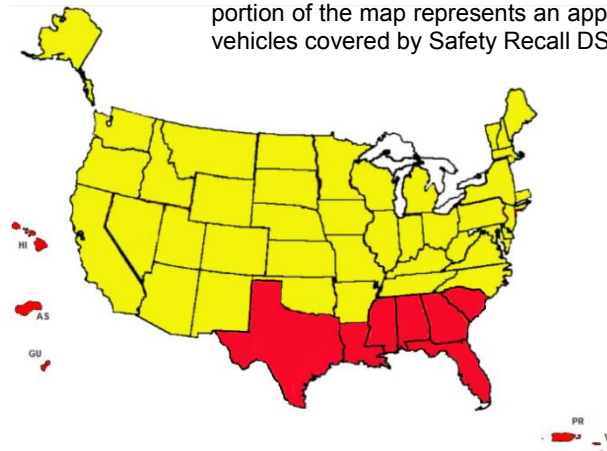

Note: This map is provided for reference purposes only. The inclusion of vehicles in Safety Recall E04 and DSF may differ from the visual representation shown on the map. Always verify vehicle Safety Recall applicability using the Technical Information System (TIS).



Safety Recall DSF/E04 - Supplemental ASM Reference
Certain 2003-2008 Model Year Corolla and Corolla Matrix Vehicles
Certain 2003-2006 Model Year Tundra Vehicles
Certain 2002-2007 Model Year Sequoia Vehicles
Front Passenger Airbag Inflator Module

Q1: Is the remedy different between DSF and E04?

A1: No, all vehicles involved in DSF and E04 will receive a replacement passenger airbag inflator as parts become available. (For certain models, the front passenger airbag assembly may be replaced.) At this time Toyota has a limited number of inflators; therefore, we are first focusing on the E04 area, because testing of recovered inflators from High Absolute Humidity areas has indicated an elevated risk of rupture.

Q2: Is Toyota offering passenger airbag disablement?

A2: No. Toyota was only offering passenger airbag disablement as a temporary measure while sufficient parts were being produced. Toyota now has sufficient parts to support vehicles covered under E04. If the front passenger airbag was previously disabled due to unavailability of parts, please advise your customer that the dealer will promptly complete the remedy inflator replacement.

Q2a: Why was Toyota temporarily offering passenger airbag disablement under Safety Recall E04?

A2a: At the time, Toyota had a very limited supply of replacement airbag inflators to support vehicles covered under E04. This was only a temporary option for customers whose vehicles are covered under E04. While parts were being produced in sufficient quantity, the National Highway Traffic Safety Administration (NHTSA) granted Toyota permission to temporarily disable airbags only in High Absolute Humidity (E04) areas, but no others.

Updated 2/24/2015

Q3: Which vehicles from Safety Recall DSF are now covered by Safety Recall E04?

A3: Approximately 257,500 vehicles originally involved in DSF are now involved in Superseding Safety Recall E04. Vehicle transferred to E04 were originally sold in, or currently/previously registered in, areas of High Absolute Humidity, encompassing the following states: Texas, Alabama, Mississippi, Georgia, South Carolina, Florida, Hawaii, and Louisiana. In addition, it includes Puerto Rico, Guam, Saipan, American Samoa, and the U.S. Virgin Islands.

Q4: What is absolute humidity?

A4: The measure of the water vapor content in the air is known as absolute humidity, and it is displayed in grams of water vapor per cubic meter of air. Higher temperature, southern coastal-type climates consistently experience the greatest concentrations of water vapor in the air, as warmer ambient air can hold more water.

Note: relative humidity is simply a percentage value and is related to current or measured temperature; therefore, areas with high relative humidity do not necessarily have high absolute humidity

Certain 2003-2008 Model Year Corolla and Corolla Matrix,
Certain 2003-2006 Model Year Tundra, and
Certain 2002-2007 Model Year Sequoia Vehicles
Front Passenger Airbag Inflator Module
SAFETY RECALL NOTICE (Remedy Notice)

This notice applies to your vehicle [VIN]
NHTSA Recall No. 15V-286 and 16V-128

URGENT SAFETY RECALL

This is an important Safety Recall.
The remedy will be performed at
NO CHARGE to you.

[VIN]

Dear Toyota Owner:

Toyota strongly recommends that you have this Safety Recall remedy performed immediately. If you do not follow the instructions in this letter, you should not drive your vehicle.

This notice is being sent to you in accordance with the requirements of the National Traffic and Motor Vehicle Safety Act. Toyota has decided that a defect, which relates to motor vehicle safety, exists in certain 2003-2008 Model Year Corolla and Corolla Matrix, certain 2003-2006 Tundra, and certain 2002-2007 Model Year Sequoia vehicles. Our records indicate that you own a vehicle that has not yet had this condition corrected.

You received this notice because our records, which are based primarily on state registration and title data, indicate that you are the current owner.

What is the Condition?

The subject vehicles are equipped with front passenger airbag inflators which may have been manufactured in such a way as to have a potential for the intrusion of moisture over time. Depending on the circumstances, this could create excessive internal pressure when the airbag is deployed and cause the inflator to rupture. In the event of an inflator rupture, metal fragments could pass through the airbag cushion material, striking the vehicle occupants and potentially resulting in serious injury or death.

What will Toyota do?

Any authorized Toyota dealer will replace the front passenger inflator assembly at **no charge** to you. (For certain models, the front passenger airbag assembly may be replaced.)

What should you do?

This is an important Safety Recall

Toyota strongly recommends that you have this remedy performed immediately. Please contact any authorized Toyota dealer to schedule an appointment. When taking your vehicle to the dealership for your service appointment, it is recommended that only the driver occupy the vehicle. If you are uncomfortable driving the vehicle to the dealership, please contact your local authorized Toyota dealer who will arrange for vehicle pick up. Until the remedy is performed, the front passenger seat should NOT be occupied.

The repair will take approximately 2 hours. However, depending on the dealer's work schedule, it may be necessary to make your vehicle available for a longer period of time.

You do not need an owner letter to have this recall completed; however, to assist the dealer in confirming vehicle eligibility, we request that you present this notice at the time of your service appointment.

If you would like to update your vehicle ownership or contact information, you may do so by registering at www.toyota.com/ownersupdate. You will need your full 17-digit Vehicle Identification Number (VIN) to input the new information.

What if you have other questions?

- ***Your local Toyota dealer will be more than happy to answer any of your questions and set up an appointment to perform the repair.***
- You can find additional information and locate a Toyota dealer in your area by going online and visiting www.toyota.com/recall.
- If you require further assistance, you may contact the Toyota Customer Experience Center at 1-888-270-9371 Monday through Friday, 5:00 am to 6:00 pm, Saturday 7:00 am through 4:00 pm Pacific Time.
- If you believe that the dealer or Toyota has failed or is unable to remedy the defect within a reasonable time, you may submit a complaint to the Administrator, National Highway Traffic Safety Administration, 1200 New Jersey Avenue S.E., Washington, D.C. 20590, or call the toll free Vehicle Safety Hot Line at 1-888-327-4236 (TTY: 1-800-424-9153), or go to <http://www.safercar.gov>.

What if you have previously paid for repairs to your vehicle for this specific condition?

If you have previously paid for repair to your vehicle for this specific condition prior to receiving this letter, please mail a copy of your repair order, proof-of-payment and proof-of-ownership to the following address for reimbursement consideration:

Toyota Motor Sales, U.S.A., Inc
Toyota Customer Experience, WC 10
19001 South Western Avenue
Torrance, CA 90509

Please note that the dealer must complete the Safety Recall remedy before reimbursement consideration requests can be processed.

If you are a vehicle lessor, Federal law requires that any vehicle lessor receiving this recall notice must forward a copy of this notice to the lessee within ten days.

We have sent this notice in the interest of your continued satisfaction with our products, and we sincerely regret any inconvenience this condition may have caused you.

Thank you for driving a Toyota.

Sincerely,
TOYOTA MOTOR SALES, U.S.A., INC.



Safety Recall E04 - For Areas of High Absolute Humidity - UPDATE
Certain 2003-2008 Model Year Corolla and Corolla Matrix Vehicles
Certain 2003-2006 Model Year Tundra Vehicles
Certain 2002-2007 Model Year Sequoia Vehicles
Front Passenger Airbag Inflator Module

Customer Frequently Asked Questions

Updated – March 1, 2016

We at Toyota care greatly about your safety. We are providing the following information to keep you informed of the details specific to this recall. Please check back frequently as this document will be updated.

This Safety Recall applies to owners of vehicles originally sold in, or currently/previously registered in, areas of High Absolute Humidity, encompassing the following states: Texas, Alabama, Mississippi, Georgia, South Carolina, Florida, Hawaii, and Louisiana. In addition, it includes Puerto Rico, Guam, Saipan, American Samoa, and the U.S. Virgin Islands.

On March 1, 2016, Toyota expanded Safety Recall E04 to include 2008 model year Corolla and Corolla Matrix vehicles.

Q1: What is the condition?

A1: The subject vehicles are equipped with front passenger airbag inflators which may have been manufactured in such a way as to have a potential for the intrusion of moisture over time. Depending on the circumstances, this could create excessive internal pressure when the airbag is deployed and cause the inflator to rupture. In the event of an inflator rupture, metal fragments could pass through the airbag cushion material, striking the vehicle occupants and potentially resulting in serious injury or death.

Q1a: What is the Inflator?

A1a: The inflator is a device contained within the airbag assembly. It contains solid propellant wafers which are ignited in the event airbag deployment is necessary. When ignited, the wafers expand into an inert gas, inflating the airbag.

Q1b: What is the cause of this condition?

A1b: The cause of the potential ruptured inflators and influence of high absolute humidity are under investigation.

Q1c: What is absolute humidity?

A1c: The measure of the water vapor content in the air is known as absolute humidity, and it is displayed in grams of water vapor per cubic meter of air. Higher temperature, southern coastal climates consistently experience the greatest concentrations of water vapor in the air, as warmer ambient air can hold more water.

Note: relative humidity is simply a percentage value and is related to current or measured temperature; therefore, areas with high relative humidity do not necessarily have high absolute humidity.

Q1d: How is humidity related to the condition?

A1d: The specific relationship of humidity to the operation of the inflator and the cause of improper airbag inflator performance and rupture is still under investigation.

Q2: What is Toyota going to do?

A2: Toyota notified all owners of vehicles covered by this safety recall except for those covered by the March 2016 expansion.

Toyota will begin notifying owners of vehicles covered by the March 2016 expansion beginning in mid-March, 2016.

Toyota dealers will replace the front passenger airbag inflator at **no charge** to the vehicle owner. (For certain models, the front passenger airbag assembly may be replaced.)

Q3: Are there any warnings that this condition exists?

A3: No. There are no warnings that this condition exists. However, the condition does not cause the airbag to activate when it should not. Also, the front passenger airbag is designed to inflate only in certain moderate to severe crashes.

Q4: What should you do?

A4: Toyota strongly recommends that you have this Safety Recall remedy performed immediately. Please contact any authorized Toyota dealer to schedule an appointment to have your front passenger airbag inflator replaced free of charge. When taking your vehicle to the dealership for your service appointment, it is recommended that only the driver occupy the vehicle. If you are uncomfortable driving the vehicle to the dealership, please contact your local authorized Toyota dealer who will arrange for vehicle pick up. Until the remedy is performed, the front passenger seat should NOT be occupied.

If you do not follow the instructions in the owner letter, you should not drive your vehicle.

Q5: Are there concerns with other airbags in the vehicle?

A5: No, this condition only applies to the front passenger airbag inflator. Other airbags in the vehicle are not affected by this condition.

Q6: Will Toyota disconnect the involved airbag or the other airbags in my vehicle?

A6: Toyota dealers have sufficient quantities of replacement parts to complete remedy repairs. Owners should promptly visit a Toyota dealer to receive their replacement airbag inflator and system check. Airbag assemblies are integral parts of the overall vehicle safety system and the integrity of the system should always be checked by drivers observing the dash mounted warning lights. Toyota dealers are not authorized to disconnect any airbag system as part of this Safety Recall action.

Q7: How is this Safety Recall related to other actions Toyota has taken regarding Takata front passenger airbag Inflator modules?

A7: Toyota has two separate recalls applicable to Takata front passenger airbag inflators. This Safety Recall (Toyota recall #E04) is applicable only to vehicles originally sold in, or currently/previously registered in, areas of high absolute humidity. The second Safety Recall (Toyota recall #DSF) involves the same model and model year vehicles in all other areas of the United States. The remedy is the same for both campaigns. The separate recall activities allow for priority parts allocation in the areas of elevated risk.

Q8: Are all vehicles involved in the Takata Front Passenger Inflator Recall Actions covered by this Safety Recall?

A8: No, this Safety Recall applies to owners of vehicles originally sold in, or currently/previously registered in, areas of High Absolute Humidity, encompassing the following states: Texas, Alabama, Mississippi, Georgia, South Carolina, Florida, Hawaii, and Louisiana. In addition, it will include Puerto Rico, Guam, Saipan, American Samoa, and the U.S. Virgin Islands. Other affected vehicles are covered by Toyota recall #DSF.

Q9: Which and how many vehicles are covered by this Safety Recall?

A9: There are approximately 1,017,000 Toyota vehicles covered by this Safety Recall.

Model	Model Year	Appx. UIO	Production Range
Corolla	2003 – 2008	622,000	Late December, 2001 - Late December, 2007
Corolla Matrix	2003 – 2008	96,000	Early January, 2002 - Mid-December, 2007
Tundra	2003 – 2006	106,000	Late July, 2002 - Late December, 2006
Sequoia	2002 – 2007	193,000	Early April, 2002 - Late November, 2007

Q9a: Are there any other Toyota/Lexus/Scion vehicles covered by this Safety Recall in the U.S.?

A9a: Yes. There are approximately 28,000 Lexus SC430 vehicles (certain 2002-2010 MY) covered by Lexus recall #ELG in the U.S.

Q10: How does Toyota obtain my mailing information?

A10: Toyota uses an industry provider who works with each state's Department of Motor Vehicles (DMV) to receive registration or title information, based upon the DMV records. Please make sure your registration or title information is correct.

Q11: Do I need my owner letter to have the remedy performed?

A11: You do not need an owner letter to have this recall completed; however, to assist the dealer in confirming vehicle eligibility, we request that you present this notice at the time of your service appointment.

Q12: What if I previously paid for repairs to my vehicle for this condition?

A12: Reimbursement consideration instruction will be provided in the remedy owner letter.

Q13: What if I have additional questions or concerns?

A13: If you have additional questions or concerns, please contact the Toyota Customer Experience Center at 1-888-270-9371 Monday through Friday, 5:00 am to 6:00 pm, or Saturday 7:00 am to 4:00 pm Pacific Time.