

To: All Toyota Dealer Principals, Service Managers, and Parts Managers

Subject: **Safety Recall E04 – For Areas of High Absolute Humidity - UPDATE**
Certain 2003 – 2007 Model Year Corolla and Corolla Matrix Vehicles
Certain 2003 – 2006 Model Year Tundra Vehicles
Certain 2002 – 2007 Model Year Sequoia Vehicles
Front Passenger Airbag Inflator Module



Updated 06/15/15:

Updated 05/15/15:

Updated 05/13/15:

Updated 02/23/15:

Updated 02/03/15:

Updated 02/03/15:

Updated 01/07/15:

Updated 11/19/14:

Updated 11/13/14:

Updated 10/27/14:

Updated 10/22/14:

High absolute humidity area updated, UIO updated

UIO Updated

Expansion of Model Years

Airbag Disablement DISCONTINUED

2005 Corolla and Corolla Matrix Part Number Added

UIO Updated

2005 Sequoia & Tundra Part Number Added

Hang Tag Part Number Added

ASM Reference Guide Added and UIO Updated

Op. Codes Added

Part Ordering Section update to clarify correct part for corresponding location

To: All Toyota Dealer Principals, Service Managers, and Parts Managers

Subject: **Safety Recall E04 – For Areas of High Absolute Humidity - UPDATE**
Certain 2003 – 2007 Model Year Corolla and Corolla Matrix Vehicles
Certain 2003 – 2006 Model Year Tundra Vehicles
Certain 2002 – 2007 Model Year Sequoia Vehicles
Front Passenger Airbag Inflator Module

This Safety Recall applies to owners of vehicles originally sold in, or currently/previously registered in, areas of High Absolute Humidity, encompassing the following states: Texas, Alabama, Mississippi, Georgia, South Carolina, Florida, Hawaii, and Louisiana. In addition, it includes Puerto Rico, Guam, Saipan, American Samoa, and the U.S. Virgin Islands.

On October 20, 2014 Toyota filed a Defect Information Report (DIR) with the National Highway Traffic Safety Administration (NHTSA) informing the agency of our intent to conduct a voluntary Safety Recall on certain 2003-2005 Model Year Corolla, Corolla Matrix, and Tundra Vehicles and certain 2002 - 2005 Model Year Sequoia Vehicles.

On May 13, 2015 Toyota filed an amended Defect Information Report (DIR) with the National Highway Traffic Safety Administration (NHTSA) informing the agency of our intent to expand this voluntary Safety Recall to cover additional 2005 - 2007 Model Year Corolla, Corolla Matrix, Sequoia, and 2005 – 2006 Model Year Tundra vehicles.

On June 16, 2015 Toyota will file an amended Defect Information Report (DIR) with the National Highway Traffic Safety Administration (NHTSA) informing the agency of our intent to expand this voluntary Safety Recall to cover additional 2003 - 2007 Model Year Corolla and Corolla Matrix, 2003 - 2006 Model Year Tundra, and 2002 - 2007 Model Year Sequoia vehicles. ***The high absolute humidity area is no longer limited to coastal areas of the specific states listed, and will also now include the state of South Carolina.***

Condition

The subject vehicles are equipped with front passenger air bag inflators which may have been manufactured in such a way as to have a potential for the intrusion of moisture over time. Depending on the circumstances, this could create excessive internal pressure when the air bag is deployed and cause the inflator to rupture. In the event of an inflator rupture, metal fragments could pass through the air bag cushion material, striking and potentially seriously injuring the vehicle occupants.

Remedy

Dealers are requested to replace the front passenger airbag inflator module at no charge to the vehicle owner.

The following information is provided to inform you of the owner notification timing and your degree of involvement.

1. Owner Letter Mailing

Toyota began mailing all customers whose vehicles are covered by this Safety Recall in late October, 2014.

Toyota will begin mailing to customers covered by the expansion of Safety Recall E04 beginning early July, 2015.

Toyota tries very hard to obtain current customer name and address information when mailing owner letters. In the event your dealership receives a notice for a vehicle that was sold prior to the Safety Recall announcement, it is the dealership's responsibility to forward the owner letter to the customer who purchased the vehicle.

If a dealer is contacted by an owner who has not yet received the notification, please **verify coverage by confirming through TIS**. Dealers should perform the procedure as outlined in the Technical Instructions located on TIS.

2. Pre-Owned Vehicles in Dealer Stock

All vehicles in dealership stock that are covered by this Safety Recall must have the passenger airbag inflator replaced before customer delivery.

3. Number and Identification of Covered Vehicles



There are approximately 953,000 Toyota vehicles covered by this Safety Recall. The majority of vehicles covered by this superseding Safety Recall were previously part of Safety Recall DSF or Limited Regional Safety Recall E0V.

If a dealer is contacted by an owner who has not yet received the notification, please **verify coverage by confirming through TIS**. Dealers should perform the procedure as outlined in the Technical Instructions located on TIS.

4. Campaign Special Service Tools

Dealerships will need to utilize the Special Service Tools provided for Safety Recall D0F. The special service tools were previously sent to your dealership on July 31, 2013.

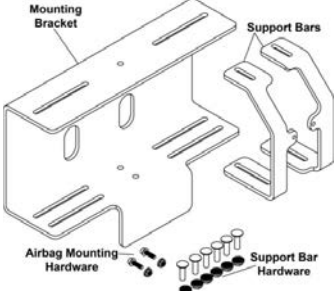
These tools are needed when performing the front passenger airbag inflator module campaign. These tools **ARE NOT** available through normal parts or tools channels. There is a limited supply of tools, but if additional tools are needed, contact your regional representative.

Name	Sample Image	Qty
Airbag Mounting Bracket & hardware		1
Barcode Scanner		1

5. Technician Training Requirements

The repair quality of covered vehicles is extremely important to Toyota. All dealership associates involved in the recall process are required to successfully complete E-Learning course **SC13A**. To ensure that all vehicles have the repair performed correctly, technicians performing this repair must also complete **SC13B** and be certified to one or more of the following levels:

- **Toyota Expert - Electrical**
- **Master**
- **Master Diagnostic Technician (MDT)**

It is the dealership's responsibility to select technicians with the above certification level or greater to perform this Safety Recall repair. Carefully review your resources, the technician skill level, and ability before assigning technicians to this repair. It is important to consider technician days off and vacation schedules to ensure there are properly trained technicians available to perform this repair at all times.

6. Campaign Specific Part Associate E- Learning Training Requirement

The airbag inflator assembly being replaced during this campaign is a Class 9 Hazmat part. Therefore Parts Associates involved in this recall are required to complete E-Learning Module (**E2140** "Safety Recall D0F – Front Passenger Airbag Inflator" found on www.uotdealer.com) This E-Learning module will explain the proper procedure for documenting and returning the airbag inflator assembly to TK Holdings Incorporated.

7. Shipping Information for Removed Inflator Assemblies

NOTE: This shipment process will be modified in the near future (approximately early July), detailed information will be provided at that time.

IMPORTANT: Do not deploy the removed inflator. The removed used inflator must be returned, within 1-2 business days after replacement directly to the manufacturer, TK Holdings Incorporated.

As the shipper, you are responsible for proper packing and document completion. The person packaging the inflator must have received hazardous material training per 49 CFR 172.702 (**EHM001** "HazmatU General Awareness Hazardous Materials Training" found on www.uotdealer.com), and the training records must be on file at your dealership. The U.S. Department of Transportation will impose substantial fines and/or penalties on the shipper if the packaging, labeling, or documentation is not properly prepared and Customer Copy of OP 900PRP form is not kept on file for a minimum of 2 years.

Each dealer will need to document a unique dealer specific CCN number on the return shipment form. You can locate your dealer unique CCN number by logging into the following website.

<http://toyota-d0f.imagespm.info/>

Default Password "XXXXX"

In addition to the E-Learning module, a laminated "Campaign D0F – 48 State FEDEX Ground Shipment Preparation" aid was previously sent to your dealership when the D0F Remedy launched. Additional copies of the aid can be found on TIS and inside of each new parts box.

8. Glove Box Reminder Hang Tags

Your dealership will be sent a package of Glove Box Reminder Hang Tags; a sample is shown below for your reference.



DISCONTINUED PROCESS

Please ensure these are applied to any vehicle where the passenger airbag is temporarily disabled. Additional glove box reminder hang tags can be ordered from the Material Distribution Center.

MDC #	Description	Package Qty
00411-INFTAG-ENG	Safety Recall E04 Glove Box Hang Tag - English	1 Package Includes 25 Tags
00411-INFTAG-SPN	Safety Recall E04 Glove Box Hang Tag - Spanish	1 Package Includes 25 Tags

9. Parts Ordering Process

SET and GST dealer initial parts allocation and parts prioritization will be handled by your distributor.

If you are in a location other than SET and GST and have a vehicle subject to E04 which requires repair, due to limited availability, the parts have been placed on Dealer Ordering Solutions (DOS) or Manual Allocation Control (MAC).

Model	Model Year	Location	Part Number	Part Description	Qty.	Order Process
Corolla Matrix	2003-2004	48 States in Continental U.S.	04003-28101	INFLATOR ASSY KIT, INSTR PNL AIRBAG	1	DOS
		USTT, Hawaii & AK	04003-11101	INFLATOR ASSY KIT, INSTR PNL AIRBAG	1	DOS
	2005-2007	48 States in Continental U.S.	04004-75201	INFLATOR ASSY KIT, INSTR PNL AIRBAG	1	MAC
		USTT, Hawaii & AK	04004-75101	INFLATOR ASSY KIT, INSTR PNL AIRBAG	1	DOS
Corolla	2003-2004	48 States in Continental U.S.	04003-28102	INFLATOR ASSY KIT, INSTR PNL AIRBAG	1	DOS
		USTT, Hawaii & AK	04003-11102	INFLATOR ASSY KIT, INSTR PNL AIRBAG	1	DOS
	2005-2007	48 States in Continental U.S.	04004-75202	INFLATOR ASSY KIT, INSTR PNL AIRBAG	1	MAC
		USTT, Hawaii & AK	04004-75102	INFLATOR ASSY KIT, INSTR PNL AIRBAG	1	DOS
Sequoia	2002-2004	48 States in Continental U.S.	04003-2810C	INFLATOR ASSY KIT, INSTR PNL AIRBAG	1	DOS
		USTT, Hawaii & AK	04003-1110C	INFLATOR ASSY KIT, INSTR PNL AIRBAG	1	DOS
	2005-2007	48 States in Continental U.S.	04004-7520C	INFLATOR ASSY KIT, INSTR PNL AIRBAG	1	MAC
		USTT, Hawaii & AK	04004-7510C	INFLATOR ASSY KIT, INSTR PNL AIRBAG	1	DOS
Tundra	2002-2004	48 States in Continental U.S.	04003-2810C	INFLATOR ASSY KIT, INSTR PNL AIRBAG	1	DOS
		USTT, Hawaii & AK	04003-1110C	INFLATOR ASSY KIT, INSTR PNL AIRBAG	1	DOS
	2005-2006	48 States in Continental U.S.	04004-7520C	INFLATOR ASSY KIT, INSTR PNL AIRBAG	1	MAC
		USTT, Hawaii & AK	04004-7510C	INFLATOR ASSY KIT, INSTR PNL AIRBAG	1	DOS

In the limited cases, where the serial number is illegible, the airbag Assembly will require replacement. Please contact your regional representative for further direction on vehicle repair and claim filing procedures.

DOS Parts Ordering Process

Orders should be placed through the dealership's facing PDC. This kit has been placed on Dealer Ordering Solutions and will be systematically released daily based on dealer ordering criteria.

Each dealership will receive specific dealer ordering criteria in an email from their facing PDC Manager based on Repair Order Volume * PDC Affected UIO. Therefore, it is vital that each dealership work with both Parts and Service to immediately file Safety Recall claims and coordinate appropriate kit orders. A sample of the Parts Allocation Report has been attached below for your reference.

<p style="text-align: center;">TOYOTA Parts Allocation Report</p> <p style="text-align: center;">99999 SAMPLE TOYOTA of NOWHERE</p> <p>The below matrix provides information for parts managed by NAPO Dealer Ordering Solution (DOS) and illustrates updates to your current daily allocation quantities. Parts shipments, arrivals and inventory quantities at your local PDC will change daily as parts are received and shipped from NAPO Suppliers. Therefore, your daily allocation quantity is subject to change based on the parts in-stock availability as well as in-transit inventory to your facing PDC. This report is provided as needed when daily allocation changes for DOS parts.</p> <p>Parts with recent changes will be illustrated from top to bottom with the most recent effective date.</p> <p>If you have any questions or concerns, please contact your facing PDC Customer Support Leader, John Q Sample at (999) 999-9999.</p>						
Part Number	Total Allocation Quantity	Allocation Quantity	Allocation Frequency	Total Allocation Shipped	Total Allocation Remaining	Effective Date



Non SET and GST MAC Parts Ordering Process

To ensure parts availability, some of these kits have been placed on Manual Allocation Control (MAC). The majority of repairs for this activity will be limited to SET and GST dealers; if you have a vehicle at your dealer applicable to E04 which requires repairs and the parts is under MAC, please send an email to PQSS_MAC@Toyota.com with the following information:

- **Subject Line: E04 MAC Release Request (Dealer Code)**
- **Dealer Code**
- **VIN Number**
- **Part Number**
- **Order Reference Number**
- **Order Date**
- **Contact Person**

Once a representative confirms the information provided, the part will be released. If there is a concern regarding the information provided, a representative will contact your dealership.

Important Notes:

- ***Once you have placed your order DO NOT upgrade or change your order status.***
- ***Failure to provide the above information within 48 hours will result in an order cancellation.***

IMPORTANT PARTS ORDERING UPDATE

All Safety Recall, Service Campaign (SSC/LSC) and Customer Support Program (CSP) parts are eligible for the Monthly Parts Return Program. Please refer to PANT Bulletin 2011-087 for campaign parts that are currently returnable under the Monthly Parts Return Program and additional details.

10. Remedy Procedures

Please refer to TIS for Technical Instructions on inspection and repair.

Conduct all applicable, non-completed Safety Recall and Service Campaigns on the vehicle during the time of appointment.

11. Warranty Reimbursement Procedure

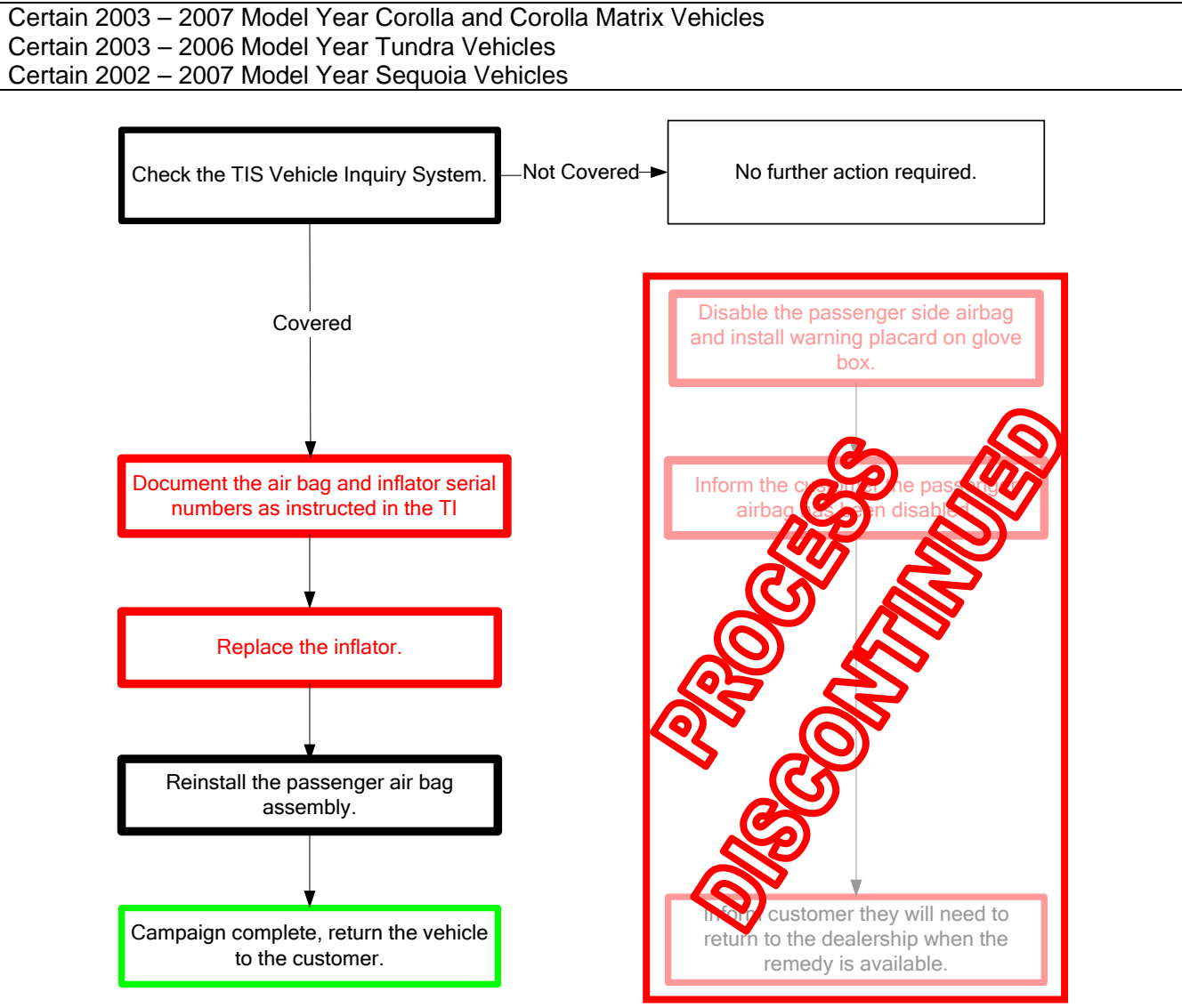

Model	Op. Code	Description	Flat Rate Hour
Tundra & Sequoia	AGGC7B	Replace Airbag Inflator Module	1.2 hr/vehicle
Corolla & Matrix	AGGC7G	Replace Airbag Inflator Module	0.9 hr/vehicle
Tundra & Sequoia Corolla & Matrix	AGGC9A	Disable Passenger Airbag Assembly and Install Glove Box Reminder Hang Tag	0.3 hr/vehicle

- **Dealers are requested to immediately stop disabling passenger airbag assemblies. All repair orders must be closed no later than February 27, 2015, and claims filed as soon as possible.**
- The flat rate times include 0.1 hours for administrative cost per unit for the dealership.
- ~~The cost of Electrical Tape and Zip Ties can be claimed as sublet type "ZZ" at maximum of \$0.25 per vehicle under Op Code AGGC9A.~~
- A customer rental vehicle through the Toyota Rent-A-Car (TRAC) can be claimed under Op. Code AGGC7B and AGGC7G for a maximum of 120 days as sublet type "RT" if a customer refused passenger airbag disablement and requests repair only. Follow the Toyota Transportation Assistance Program (TTAP) guidelines.
- Towing can be claimed under Op. Code AGGC7B, AGGC7G, ~~AGGC9A~~, and AGGC7W for a maximum of \$250 as sublet type "TW" in the event the customer requested vehicle pickup.

In limited instances, a Sequoia vehicle may have an inflator utilizing a large retaining hex nut on the right side. These vehicles are not involved in this Safety Recall. **Refer to the Sequoia Technical Instructions Section VIII-2 for additional details.**

Model	Op. Code	Description	Flat Rate Hour
Sequoia (ONLY)	AGGC7W	Large Retaining Hex Nut Found Vehicle not Involved Under this Safety Recall (Refer to the Sequoia Technical Instructions Section VIII-2)	0.3 hr/vehicle

12. Campaign Designation Decoder

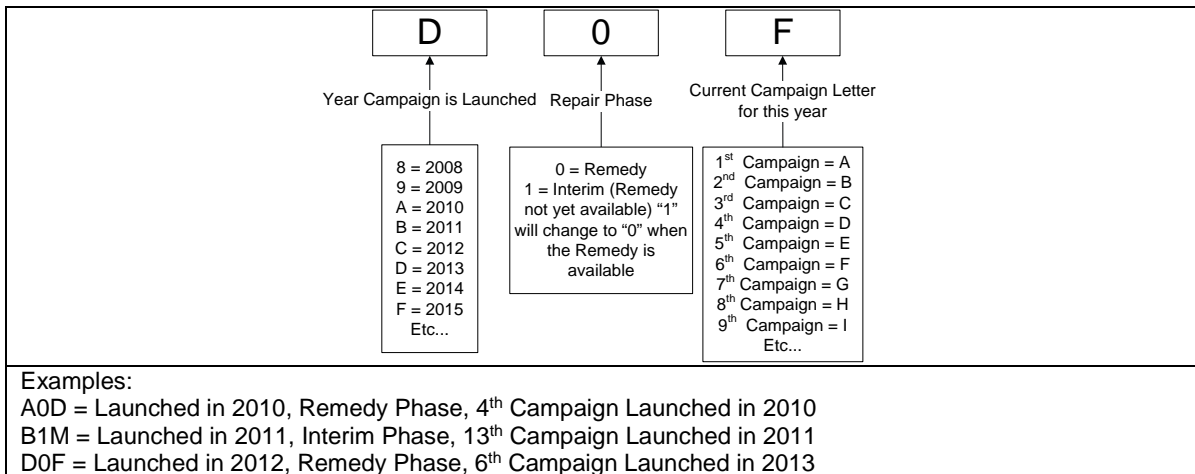

13. Repair Quality Confirmation

The repair quality of covered vehicles is extremely important to Toyota. To help ensure that all vehicles have the repair performed correctly, please designate at least one associate (someone other than the individual who performed the repair) to verify the repair quality of every vehicle prior to customer delivery.

14. **Media Contacts**

If you are a dealership associate and have any questions, please contact your District Service/Parts Manager. ***In the event you are contacted by the News media***, it is imperative that all media contacts (local and national) receive a consistent message. In this regard, all media contacts must be directed to Cindy Knight, (310) 468-2170 in Toyota Corporate Communications. (Please do not provide this number to customers.)

15. **Customer Contacts**

A FAQ is attached to help respond to any customer concerns. If the customer has any further questions, they are requested to contact the Toyota Customer Experience Center. The Toyota Customer Experience Center can be reached at 1-888-270-9371 Monday through Friday, 5:00 am to 6:00 pm, or Saturday 7:00 am to 4:00 pm Pacific Time.

Please note the attached FAQ is published on the www.Toyota.com website for customer viewing.

Please review this entire package with your Service and Parts staff to familiarize them with the proper step-by-step procedures required to implement this Safety Recall.

Thank you for your cooperation.
TOYOTA MOTOR SALES, U.S.A., INC.



Safety Recall E04 – For Areas of High Absolute Humidity - UPDATE
Certain 2003 – 2007 Model Year Corolla and Corolla Matrix Vehicles
Certain 2003 – 2006 Model Year Tundra Vehicles
Certain 2002 – 2007 Model Year Sequoia Vehicles
Front Passenger Airbag Inflator Module

Customer Frequently Asked Questions

Published June 15, 2015

This Safety Recall applies to owners of vehicles originally sold in, or currently/previously registered in, areas of High Absolute Humidity, encompassing the following states: Texas, Alabama, Mississippi, Georgia, South Carolina, Florida, Hawaii, and Louisiana. In addition, it will include Puerto Rico, Guam, Saipan, American Samoa, and the U.S. Virgin Islands.

On June 16, 2015 Toyota will file an amended Defect Information Report (DIR) with the National Highway Traffic Safety Administration (NHTSA) informing the agency of our intent to expand this voluntary Safety Recall to cover additional 2003 - 2007 Model Year Corolla and Corolla Matrix, 2003 – 2006 Model Year Tundra, and 2002 – 2007 Model Year Sequoia vehicles. ***The high absolute humidity area is no longer limited to coastal areas of the specific states listed, and will also now include the state of South Carolina.***

We at Toyota care greatly about your safety. We are providing the following information to keep you informed of the details specific to this recall. Please check back frequently as this document will be updated.

Q1: What is the condition?

A1: The subject vehicles are equipped with front passenger air bag inflators which may have been manufactured in such a way as to have a potential for the intrusion of moisture over time. Depending on the circumstances, this could create excessive internal pressure when the air bag is deployed and cause the inflator to rupture. In the event of an inflator rupture, metal fragments could pass through the air bag cushion material, striking and potentially seriously injuring the vehicle occupants.

Q1a: What is the Inflator?

A1a: The inflator is a device contained within the airbag assembly. It contains solid propellant wafers which are ignited in the event airbag deployment is necessary. When ignited, the wafers expand into an inert gas, inflating the airbag.

Q1b: What is the cause of this condition?

A1b: The cause of the potential ruptured inflators and influence of high absolute humidity are under investigation.

Q1c: What is absolute humidity?

A1c: The measure of the water vapor content in the air is known as absolute humidity, and it is displayed in grams of water vapor per cubic meter of air. Higher temperature, southern coastal climates consistently experience the greatest concentrations of water vapor in the air, as warmer ambient air can hold more water.

Note: relative humidity is simply a percentage value and is related to current or measured temperature; therefore, areas with high relative humidity do not necessarily have high absolute humidity.

Q1d: How is humidity related to the condition?

A1d: The specific relationship of humidity to the operation of the inflator and the cause of improper airbag inflator performance and rupture is still under investigation.

Q2: What is Toyota going to do?

A2: Owners of vehicles covered by this Safety Recall began receiving notification by first class mail in late October, 2014.

Toyota will begin mailing to customers covered by the expansion of Safety Recall E04 beginning early July, 2015.

Toyota Dealers are requested to replace the front passenger airbag inflator module at **no charge** to the vehicle owner.

Q3: Are there any warnings that this condition exists?

A3: No. There are no warnings that this condition exists. However, the condition does not cause the airbag to activate when it should not. Also, the front passenger airbag is designed to inflate only in certain moderate to severe crashes.

Q4: What should you do?

A4: Toyota strongly recommends that you have this Safety Recall remedy performed immediately. Please contact any authorized Toyota dealer to schedule an appointment. When taking your vehicle to the dealership for your service appointment, it is recommended that only the driver occupy the vehicle. If you are uncomfortable driving the vehicle to the dealership, please contact your local authorized Toyota dealer who will arrange for vehicle pick up. Until the remedy is performed, the front passenger seat should NOT be occupied.

If you do not follow the instructions in the owner letter, you should not drive your vehicle.

Q5: Are there concerns with other airbags in the vehicle?

A5: No, this condition only applies to the front passenger airbag inflator module. Other airbags in the vehicle are not affected by this condition.

Q6: How is this Safety Recall related to other actions Toyota is taken regarding Takata front passenger airbag inflator modules?

A6: Toyota has two separate recalls applicable to Takata front passenger airbag inflators. Safety Recall E04 is applicable only to vehicles originally sold in or currently/previously registered in areas of high absolute humidity. The second Safety Recall, DSF, involves the same model and model year vehicles in all other areas of the United States. The remedy is the same for both campaigns. The separate recall activities allow for priority parts allocation in the areas of elevated risk.

Q7: Are all vehicle involved in the previous Takata Front Passenger Inflator Module Recall Actions covered by this Safety Recall?

A7: No, this Safety Recall applies to owners of vehicles originally sold in, or currently/previously registered in, areas of High Absolute Humidity, encompassing the following states: Texas, Alabama, Mississippi, Georgia, South Carolina, Florida, Hawaii, and Louisiana. In addition, it will include Puerto Rico, Guam, Saipan, American Samoa, and the U.S. Virgin Islands.

Q8: Which and how many vehicles are covered by this Safety Recall?

A8: There are approximately 953,000 Toyota vehicles covered by this Safety Recall. Many of the vehicles covered by this superseding Safety Recall were previously part of Safety Recall DSF or Limited Regional Safety Recall E0V.

Model	Model Year	Appx. UIO	Production Range
Corolla	2003 – 2007	564,000	Late December, 2001 through Early July 2007
Corolla Matrix	2003 – 2007	90,000	Early January, 2002 through Early June 2007
Tundra	2003 – 2006	106,000	Late July, 2002 through Late December, 2006
Sequoia	2002 – 2007	193,000	Early April, 2002 through Late November, 2007

Q9a: Are there any other Lexus/Toyota/Scion vehicles covered by this Safety Recall in the U.S.?

A9a: Yes. There are approximately 26,000 SC430 vehicles (certain 2002-2007 MY) covered by this Safety Recall in the US.

Q9: How does Toyota obtain my mailing information?

A9: Toyota uses an industry provider who works with each state's Department of Motor Vehicles (DMV) to receive registration or title information, based upon the DMV records. Please make sure your registration or title information is correct.

Q10: Do I need my owner letter to have the remedy performed?

A10: You do not need an owner letter to have this recall completed; however, to assist the dealer in confirming vehicle eligibility, we request that you present this notice at the time of your service appointment.

Q11: What if I previously paid for repairs to my vehicle for this condition?

A11: Reimbursement consideration instruction will be provided in the remedy owner letter.

Q12: What if I have additional questions or concerns?

A12: If you have additional questions or concerns, please contact the Toyota Customer Experience Center at 1-888-270-9371 Monday through Friday, 5:00 am to 6:00 pm, or Saturday 7:00 am to 4:00 pm Pacific Time.



Safety Recall DSF(D3F)/E04 - Supplemental ASM Reference
Certain 2003 - 2007 Model Year Corolla and Corolla Matrix Vehicles
Certain 2003 - 2006 Model Year Tundra Vehicles
Certain 2002 - 2007 Model Year Sequoia Vehicles
Front Passenger Airbag Inflator Module

Q1: Is the remedy different between DSF and E04?

A1: No, all vehicles involved in DSF and E04 will receive a replacement passenger airbag inflator as parts become available. At this time Toyota has a limited number of inflators; therefore, we are first focusing on the E04 area, because testing of recovered inflators from High Absolute Humidity areas has indicated an increased risk of rupture.

Q2: Is Toyota offering passenger airbag disablement?

A2: No. Toyota was only offering passenger airbag disablement as a temporary measure while sufficient parts were being produced. Toyota now has sufficient parts to support vehicles covered under E04. If you previously had the front passenger airbag disabled due to unavailability of parts, please contact your dealer promptly to complete inflator replacement.

Q2a: Why was Toyota temporarily offering passenger airbag disablement under Safety Recall E04?

A2a: At the time, Toyota had a very limited supply of replacement airbag inflators to support vehicles covered under E04. This was only a temporary option for customers whose vehicles are covered under E04. While parts were being produced in sufficient quantity, the National Highway Traffic Safety Administration (NHTSA) granted Toyota permission to temporarily disable airbags only in High Absolute Humidity (E04) areas, but no others.

Updated 2/24/2015

Q3: Which vehicles from Safety Recall DSF (D3F) are now covered by Superseding Safety Recall E04?

A3: Approximately 257,500 vehicles originally involved in DSF (D3F) are now involved in Superseding Safety Recall E04. Vehicle transferred to E04 were originally sold in, or currently/previously registered in, areas of High Absolute Humidity, encompassing the following states: Texas, Alabama, Mississippi, Georgia, South Carolina, Florida, Hawaii, and Louisiana. In addition, it will include Puerto Rico, Guam, Saipan, American Samoa, and the U.S. Virgin Islands.

Q4: When does Toyota anticipate the remedy will be available for the remaining portion of Safety Recall DSF?

A4: Toyota is currently working on obtaining the remedy parts for subsequent phases of Safety Recall DSF. Additional information will be provided as remedy parts become available.

Q5: What is absolute humidity?

A5: The measure of the water vapor content in the air is known as absolute humidity, and it is displayed in grams of water vapor per cubic meter of air. Higher temperature, southern coastal-type climates consistently experience the greatest concentrations of water vapor in the air, as warmer ambient air can hold more water.

Note: relative humidity is simply a percentage value and is related to current or measured temperature; therefore, areas with high relative humidity do not necessarily have high absolute humidity.

Certain 2003-2005 Model Year Corolla, Corolla Matrix, and Tundra and
Certain 2002 - 2005 Model Year Sequoia Vehicles
Front Passenger Airbag Inflator Module

SAFETY RECALL NOTICE

This notice applies to your vehicle [VIN]

URGENT SAFETY RECALL

This is an important Safety Recall.
The remedy will be performed at
NO CHARGE to you.

[VIN]

Dear Toyota Owner:

Toyota strongly recommends that you have this Safety Recall remedy performed immediately. If you do not follow the instructions in this letter, you should not drive your vehicle.

This notice is being sent to you in accordance with the requirements of the National Traffic and Motor Vehicle Safety Act. Toyota has decided that a defect, which relates to motor vehicle safety, exists in certain 2003 - 2005 Model Year Corolla, Corolla Matrix, Tundra, and certain 2002 – 2005 Model Year Sequoia vehicles.

You received this notice because our records, which are based primarily on state registration and title data, indicate that you are the current owner.

What is the Condition?

The subject vehicles are equipped with front passenger air bag assemblies. When operated in areas with consistently high absolute humidity, the front passenger air bag inflator could be susceptible to rupture and the front passenger air bag could deploy abnormally in a crash, increasing the risk of injury to the occupant.

What will Toyota do?

Any authorized Toyota dealer will replace the front passenger inflator assembly at **no charge** to you.

In the event a front passenger inflator assembly is not available, at the time of vehicle service, the dealer will follow procedures to temporarily disable the front passenger air bag assembly. In addition the dealer will install a glove box hang tag informing occupants that the front passenger seat should not be occupied until the front passenger inflator assembly is replaced and the airbag is fully functional.

What should you do?

This is an important Safety Recall

Toyota strongly recommends that you have this remedy performed immediately. Please contact any authorized Toyota dealer to schedule an appointment. When taking your vehicle to the dealership for your service appointment it is recommended that only the driver occupy the vehicle. If you are uncomfortable driving the vehicle to the dealership, please contact your local authorized Toyota dealer who will arrange for vehicle pick up. Until the remedy is performed, the front passenger seat should NOT be occupied.

The repair will take approximately 2 hours. However, depending on the dealer's work schedule, it may be necessary to make your vehicle available for a longer period of time.

You do not need an owner letter to have this recall completed; however, to assist the dealer in confirming vehicle eligibility, we request that you present this notice at the time of your service appointment.

If you would like to update your vehicle ownership or contact information, you may do so by registering at www.toyota.com/ownersupdate. You will need your full 17-digit Vehicle Identification Number (VIN) to input the new information.

What if you have other questions?

- ***Your local Toyota dealer will be more than happy to answer any of your questions and set up an appointment to perform the repair.***
- You can find additional information and locate a Toyota dealer in your area by going online and visiting www.toyota.com/recall.
- If you require further assistance, you may contact the Toyota Customer Experience Center at 1-888-270-9371 Monday through Friday, 5:00 am to 6:00 pm, Saturday 7:00 am through 4:00 pm Pacific Time.

If you believe that the dealer or Toyota has failed or is unable to remedy the defect within a reasonable time, you may submit a complaint to the Administrator, National Highway Traffic Safety Administration, 1200 New Jersey Avenue S.E., Washington, D.C. 20590, or call the toll free Vehicle Safety Hot Line at 1-888-327-4236 (TTY: 1-800-424-9153), or go to <http://www.safercar.gov>.

What if you have previously paid for repairs to your vehicle for this specific condition?

If you have previously paid for repair to your vehicle for this specific condition prior to receiving this letter, please mail a copy of your repair order, proof-of-payment and proof-of-ownership to the following address for reimbursement consideration:

Toyota Motor Sales, U.S.A., Inc
Toyota Customer Experience, WC 10
19001 South Western Avenue
Torrance, CA 90509

Please note that the dealer must complete the Safety Recall remedy before reimbursement consideration requests can be processed.

If you are a vehicle lessor, Federal law requires that any vehicle lessor receiving this recall notice must forward a copy of this notice to the lessee within ten days.

We have sent this notice in the interest of your continued satisfaction with our products, and we sincerely regret any inconvenience this condition may have caused you.

Thank you for driving a Toyota.

Sincerely,
TOYOTA MOTOR SALES, U.S.A., INC.

SAMPLE