

JERR-DAN CORPORATION

13224 FOUNTAINHEAD PLAZA
HAGERSTOWN, MD 21742
1-800-926-9666
www.jerr-dan.com

SAFETY RECALL NOTICE

Attention: Jerr-Dan Dealer
Subject: Replacement of Underlift Tilt Counterbalance Valve
Models Affected: Standard Duty Wrecker, MPL-NGS, MPL-NG and MPL40
Date: April 24, 2015
Reference Number: 15V-161

Purpose:

Jerr-Dan Corporation has decided that a defect, which relates to motor vehicle safety, exists in certain model year 2010 Standard Duty Wrecker vehicles, manufactured August 3, 2010 through September 30, 2010. The defect could exist in the counterbalance valve for the underlift tilt cylinder. Jerr-Dan has determined that over time, the internal components of the counterbalance valve can become damaged, allowing the underlift tilt cylinder to drift down from its initial position during towing of a disabled vehicle, allowing the towed vehicle to make contact with the road surface and increasing the risk of a vehicle crash. This Recall must be completed on all affected units.

Required Action:

1. Owners of the affected Standard Duty Wreckers, manufactured August 3, 2010 through September 30, 2010, have received a Safety Recall Notice, NHTSA Campaign Number – 15V-161 (example enclosed). Owners of the affected trucks have been instructed to contact their local Jerr-Dan dealer to have this Recall performed.
2. Attached is a copy of the master serial number list of the affected Standard Duty Wreckers. Please verify the serial number is listed prior to performing any updates. Once the serial number has been verified as an affected Standard Duty Wrecker, please schedule with the owner of the truck an agreed upon time for completion of the update.
3. Discard any of Jerr-Dan Part number 7935000354 in your stock to prevent any further use.
4. A Counterbalance Replacement Kit, # 2890257 must be ordered for each affected unit. When ordering a Kit, you will be required to provide the serial number of the affected unit and will be charged (debited) for the cost of each Kit.

5. Upon receipt of the Kit, replace the underlift tilt circuit counterbalance valve on each affected unit as per the enclosed Underlift Tilt Circuit Counterbalance Valve Replacement Procedure. The time to complete the Procedure may vary due to a number of factors; however the estimated time for the Underlift Tilt Circuit Counterbalance Valve Replacement procedure is approximately half (1/2) an hour under normal circumstances.
6. Promptly notify Jerr-Dan of the completion of this Bulletin by sending the enclosed Campaign Completion Form to Jerr-Dan in accordance with the instructions on the form.
7. Please be reminded that it is a violation of Federal law for you to sell or lease an affected Standard Duty Wrecker covered by this notification until this recall has been performed on the Standard Duty Wrecker. Substantial civil penalties apply to violations of this law.

Reimbursement of Costs:

To receive reimbursement, the entity must file a warranty claim through the standard warranty process. When filing this claim, please reference "Notice # **15V-161**" so that proper credit may be issued.

Once Jerr-Dan is notified of the completion of the Underlift Tilt Circuit Counterbalance Valve Replacement Procedure, the responsible account will be reimbursed for the initial cost of the Counterbalance Replacement Kit that was ordered, # 2890257, and up to half (1/2) an hour of labor.

Contacts:

If you have any questions or need further information, please contact the Product Safety and Reliability Department by email (productsafety@jerrdan.com) or telephone (800-926-9666).

Enclosures:

Underlift Tilt Circuit Counterbalance Valve Replacement Procedure

Master Serial Number List

Example – Safety Recall Notice (Product Owner Notification)

Owner Update Form

Campaign Completion Form

PROCEDURE: Underlift Tilt Circuit Counterbalance Valve Replacement Procedure
MODELS: Jerr-Dan Standard Duty Wrecker, Models MPL-NGS, MPL-NG and MPL40

Tools and Equipment Required:

- Standard mechanic tools
- Hydraulic fluid drip pan
- Shop towels

Personnel Required:

- Qualified equipment mechanic

Parts/Material Required:

- Counterbalance Valve Replacement Kit, #2890257. One kit per affected machine, containing the following components:
 - Counterbalance valve assembly, P/N 1001173683, qty 1

CAUTION: USE ALL APPLICABLE SAFETY PRECAUTIONS WHILE WORKING ON, UNDER OR AROUND ANY MACHINERY.

Procedure:

1. Position truck on a firm and level surface.
2. Properly chock the wheels of the truck.
3. Lower the underlift so that it sits on the ground surface.
4. Tag the truck out of service to prevent further use during the course of this procedure.
5. Ensure that the engine has been shut off and the hydraulic fluid has cooled.
6. Thoroughly clean the area around the hydraulic valve assembly area of the underlift tilt cylinder.
7. Remove necessary items and components in order to gain access to the underlift tilt cylinder. Reference Illustration #1.

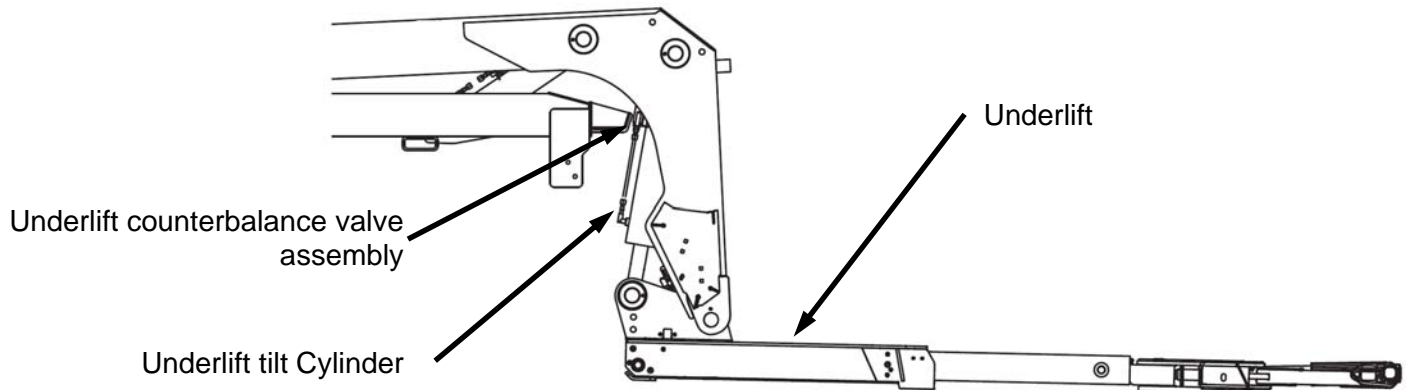

Illustration #1

8. Position a hydraulic fluid drip pan, if possible, under the fittings attached to the valve assembly area of the underlift tilt cylinder.

Reference Illustration #2 for steps 9 through 15

9. Mark all hydraulic connects as to their location on the counterbalance valve assembly.
10. Using a wrench, slowly loosen the hydraulic fittings to allow any excess pressure to escape.
11. Disconnect all hydraulic fittings that are attached to the counterbalance valve assembly. Use shop towels to absorb any residual hydraulic fluid.
12. Unbolt the two bolts that attach the valve assembly to the cylinder. Discard the valve assembly to prevent further use.
13. Properly attach the new valve assembly provided in the kit with the hardware from step #12. Properly torque the hardware.
14. Properly reinstall the removed hydraulic fittings from step # 11 into the new valve assembly at the proper location. Properly tighten all hydraulic fittings.
15. Clean any residual hydraulic fluid with a shop towel. Remove the hydraulic fluid drip pan and properly dispose of any oil.
16. Reassemble the unit and prepare for operation.
17. The unit may be returned to service once proper operation is confirmed.

Should any further discrepancies be discovered during the completion of this procedure, contact Jerr-Dan immediately for further evaluation.



Mark hydraulic lines to their positions and remove from the counterbalance valve assembly

Underlift tilt cylinder counterbalance valve assembly

Illustration #2

Safety Recall Notice #15V-161
Master Serial Number Listing

B100044	B106387
B100052	B106388
B100053	B106389
B100056	B106391
B106188	B106392
B106225	B106393
B106226	B106394
B106227	B106424
B106238	B106425
B106239	B106426
B106242	B106509
B106267	B106511
B106270	W040452
B106271	W040647
B106306	W040682
B106308	W040683
B106310	W040832
B106326	W040855
B106342	W040946
B106343	W041014
B106344	W041057
B106347	W041058
B106375	W041059
B106380	W041061
B106385	W041064

JERR - DAN CORPORATION

13224 FOUNTAINHEAD PLAZA
HAGERSTOWN, MD 21742
1-800-926-9666
www.jerr-dan.com

SAFETY RECALL NOTICE

Date: April 24, 2015

Reference Number: 15V-161

Attn: Jerr-Dan Product Owner

Re: Standard Duty Wrecker Underlift

Subject: Underlift Counterbalance Valve Replacement

This notice is sent to you in accordance with the requirements of the National Traffic and Motor Vehicle Safety Act.

REASON FOR THIS RECALL

Jerr-Dan Corporation has decided that a defect, which relates to motor vehicle safety, exists in certain model year 2010 Standard Duty Wrecker vehicles, manufactured August 3, 2010 through September 30, 2010. The defect could exist with the counterbalance valve for the underlift tilt cylinder. Jerr-Dan has determined that over time, the internal components of the counterbalance valve become damaged, allowing the underlift tilt cylinder to drift down from its initial position during towing of a disabled vehicle and allowing the towed vehicle to make contact with the road surface and increasing the risk of a vehicle crash. This Recall must be completed on all affected units.

WHAT SHOULD YOU DO?

1. Please contact your Jerr-Dan Dealer as soon as possible to arrange a service date and so the dealer may order the necessary parts for the repair. Instructions for making this correction have been sent to your dealer and the parts are available. The labor time necessary to perform this service correction is approximately half (1/2) an hour. However, you should contact your dealer for information on the amount of time that will be needed to schedule and process your vehicle.

2. Discard any of Jerr-Dan Part number 7935000354 in your stock to prevent any further use.

Your Jerr-Dan dealer is best equipped to obtain parts and provide service to ensure that this condition is corrected as promptly as possible on your vehicle. If, however, you take your vehicle to your dealer on the agreed service date, and they do not remedy this condition on that date or within three (3) days, we recommend you contact the Jerr-Dan Product Safety and Reliability Department by:

Email: productsafety@jerrdan.com

Telephone: 1-800-926-9666

After contacting your dealer and Jerr-Dan Product Safety and Reliability Department, if you are still not able to have the safety defect remedied without charge and within a reasonable time, you may wish to write the Administrator, National Highway Traffic Safety Administration, 1200 New Jersey Avenue, S.E., Washington, DC 20590 or call 1-888-327-4236 (TTY: 1-800-424-9153); or go to <http://www.safercar.gov>

If you had this repair performed before you received this letter, you may be eligible to receive reimbursement for the cost of obtaining a pre-notification remedy of the problem associated with this recall. For more information please contact Jerr-Dan at:

Email: productsafety@jerrdan.com

Telephone: 1-800-926-9666

Owner Verification:

An Individual Serial Number List is enclosed, indicating Standard Duty Wreckers that you own according to Jerr-Dan records. Please review and verify your ownership of the units on the enclosed Individual Serial Number List. If the information specified on the Individual Serial Number List is incorrect, immediately complete the enclosed Owner Update Form for each incorrect unit and send the updated information to Jerr-Dan in accordance with the instructions on the form. Jerr-Dan will then contact the new owner of the wrecker.

Federal law requires any lessor who receives a notification of a determination of a safety-related defect or noncompliance pertaining to any leased motor vehicle shall send the notice to the lessee within 10 days.

We are sorry for any this inconvenience. However, we have taken this action in the interest of your safety and continued satisfaction with our products.

Jerr-Dan Corporation
Product Safety and Reliability Dept.

Enclosures:

Owner Update Form

Individual Serial Number List



Product Owner Update Form

- Complete ALL Sections of this form and mail or fax to the appropriate location specified below.
- It is very important to keep Jerr-Dan updated with current product ownership information. By registering the products you own, you can ensure that Jerr-Dan will be better prepared to serve you and provide support.
- DO NOT include Lessees/Renters of Leased/Rented Products on this form.
- To report a *Scrapped, Stolen, Missing, or Recovered product*, use the "Jerr-Dan Product Status Verification Form No. PSR015-JDC."

Product Information

Make: _____ Model: _____

Serial Number or VIN/PIN: _____

Make: _____ Model: _____

Serial Number or VIN/PIN: _____

Make: _____ Model: _____

Serial Number or VIN/PIN: _____

Make: _____ Model: _____

Serial Number or VIN/PIN: _____

Contact Information

Company Name: _____

Street Address: _____

Address1: _____

City: _____ State/Province: _____ Zip/Postal Code: _____ Country: _____

Telephone: _____ Facsimile: _____ E-Mail Address: _____

Contact Name: _____ Signature: _____ Date: _____

***Product Owner Information** (Same as Contact)

Company Name: _____

Street Address: _____

Address1: _____

City: _____ State/Province: _____ Zip/Postal Code: _____ Country: _____

Telephone: _____ Facsimile: _____ E-Mail/Website Address: _____

Mail or Fax Completed Form to:

**Jerr-Dan Corporation
Product Safety & Reliability Department
13224 Fountainhead Plaza
Hagerstown, MD 21742**

**Facsimile: 301/745-3713
Email: productsafety@jerr-dan.com**



Product Safety & Reliability Department
13224 Fountainhead Plaza
Hagerstown, MD 21742
Telephone: (800) 926-9666
Facsimile: (301) 745-3713
E-Mail Address: ProductSafety@Jerr-Dan.com

Campaign Completion Form	➤ Complete <u>ALL</u> Sections of this form and mail or fax to the location specified above.
---------------------------------	--

Product Information		
Make: _____	Model: _____	Hour Meter Reading: _____
Serial Number or VIN/PIN: _____		

Completion Information	
Bulletin Number: _____	Completion Date: _____

Completed By Contact Information			
Company Name: _____			
Street Address: _____		Address1: _____	
City: _____	State/Province: _____	Zip/Postal Code: _____	Country: _____
Telephone: _____	Facsimile: _____	E-Mail Address: _____	
Contact Name: _____	Signature: _____	Date: _____	

* ***If you would like to update the current ownership information that we have on file for the above referenced unit, please complete and return an Owner Update Form (PSR008-JDC).***