

# SERVICE BULLETIN



UTILITY TRAILER MANUFACTURING CO.

## SB-08-174 Rev. A

Re-Issue date: February 23, 2015

### Haldex Life Seal Long Stroke Brake Chamber - Recall

#### **UTM Reference: #388011**

Per NHTSA recall #14E075, improper manufacturing of the Haldex Life Seal Long Stroke Brake Chamber - this Service Bulletin provides instructions for indentifying the chambers and the proper contacts and addresses for replacement under Haldex recall #14#075.

#### **Trailer Identification:**

Applicable trailers can be identified as noted in WN 388011. If you are unsure, contact The Haldex Hotline at 1-800-752-2501.

#### **The following trailers built with Haldex Life Seal 30/30 Chambers**

- Dry Vans built between January 9, 2014 and February 12, 2015
- Reefer Vans built between January 9, 2014 and February 12, 2015
- Flat Bed built between January 9, 2014 and February 12, 2015

Dealers that have trailers listed on warranty note (388011) will be contacted directly by UTM and provided a VIN list of trailers affected by recall #14E075. Please see [NHTSA recall #14E075](#) for more details.

#### **Brake Chamber Replacement:**

1. Identify trailer VIN per the list provided by Utility Field Service
2. Call Haldex for the necessary supply of Gold Seal 3030 Long Stroke chambers
3. Replace all Haldex Life Seal 3030 Long Stroke chambers as pertaining to the recall
4. Replace with Haldex Gold Seal 3030 Long Stroke chambers
  - ❖ Gold Seal 3030 long stroke will carry a 6 year warranty through Haldex
5. Fill out attached Gold Seal Replacement Form and return to Haldex
6. Ship take-off Haldex Life Seal 3030 Long Stroke chambers per the following instructions:

# SERVICE BULLETIN



UTILITY TRAILER MANUFACTURING CO.

## **Shipments with a net weight under 300 lbs:**

Pack in individual boxes, each weighing less than 50 lbs.

### **Ship collect to:**

Haldex  
10715 NW Airworld Drive  
Kansas City, MO 64153  
**Use UPS account AW5547**

**\*Please include LSNG32014 in UPS reference field 1 or 2.**

## **Shipments with a net weight over 300 lbs (but less than 10,000 lbs):**

Pack in individual boxes, stack and wrap on a pallet.

### **Ship to:**

Haldex  
10715 NW Airworld Drive  
Kansas City, MO 64153  
**Bill charges as 'collect'**  
**Use FedEx Freight, priority service, account 558485612**

**\*Please include LSNG32014 on the carrier's bill of lading.**

## **Shipments over 10,000 lbs:**

Please contact Haldex customer service hotline at 1-800-752-2501

Any questions regarding this service bulletin should be directed to Utility's Field Service Department at 800-423-6591.

Field Service Department  
UTILITY TRAILER MANUFACTURING COMPANY

# Life Seal® Identification



This specification defines a seven character alpha numeric date code. The first three digits indicate the Julian calendar day of the year. The fourth alpha character indicates the production shift. The fifth and sixth digits indicate the last two numbers of the year of manufacture. The last alpha character indicates the manufacturing location.

Example: Assembly built on first shift in Apodaca, Mexico on October 29, 2013



Port Side

Stamp Side



| Julian Date | Shift | Year | Location | Mfg. Line |
|-------------|-------|------|----------|-----------|
| 302         | A     | 13   | A        | 3         |
| 1533030302  |       |      |          |           |
| Part Number |       |      |          |           |

# Life Seal<sup>®</sup> Identification

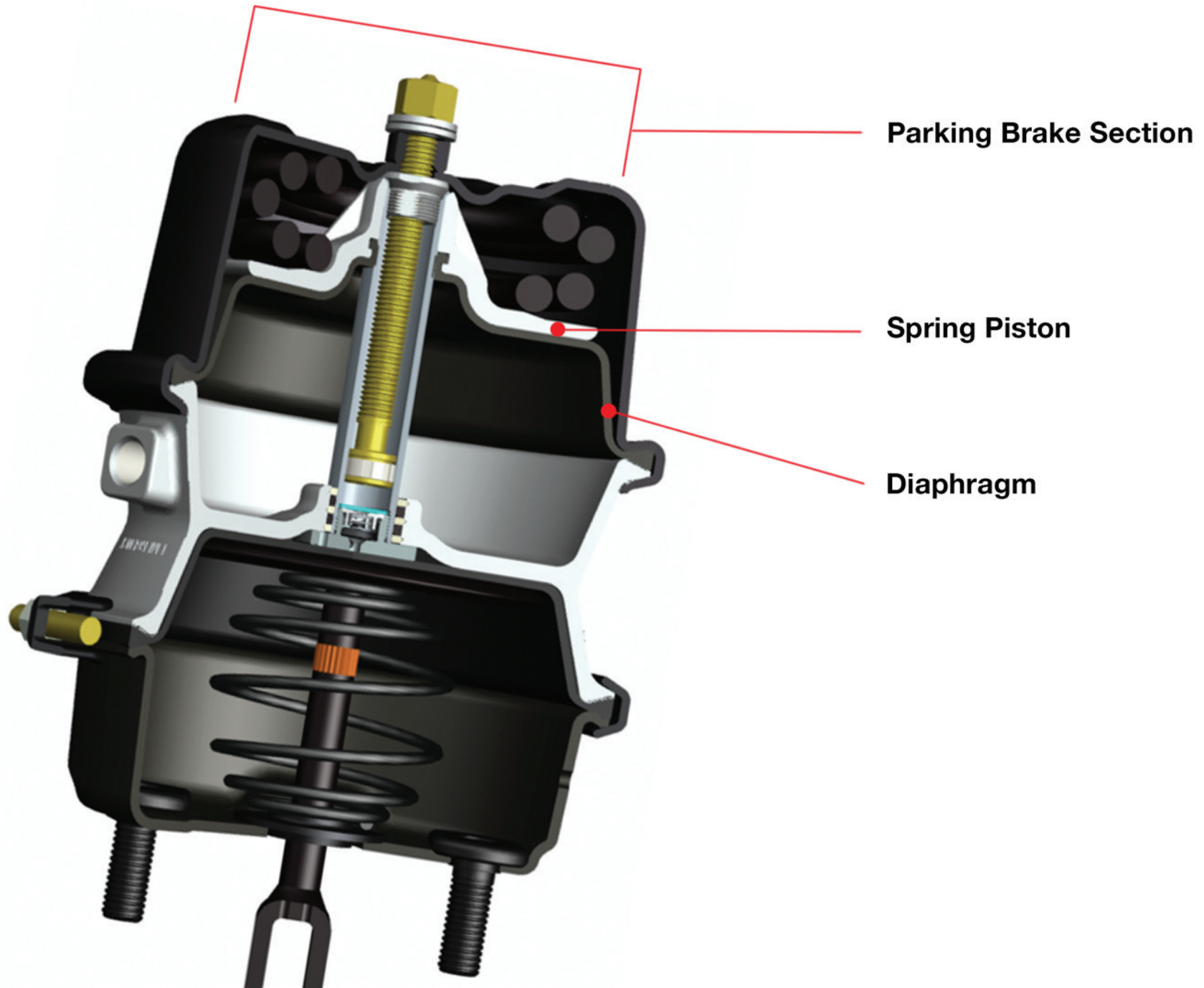

# Life Seal® Identification



| Julian Date Calendar<br>2014 |     |     |     |     |     |     |     |     |     |     |     |     |
|------------------------------|-----|-----|-----|-----|-----|-----|-----|-----|-----|-----|-----|-----|
| Day                          | Jan | Feb | Mar | Apr | May | Jun | Jul | Aug | Sep | Oct | Nov | Dec |
| 1                            | 1   | 32  | 60  | 91  | 121 | 152 | 182 | 213 | 244 | 274 | 305 | 335 |
| 2                            | 2   | 33  | 61  | 92  | 122 | 153 | 183 | 214 | 245 | 275 | 306 | 336 |
| 3                            | 3   | 34  | 62  | 93  | 123 | 154 | 184 | 215 | 246 | 276 | 307 | 337 |
| 4                            | 4   | 35  | 63  | 94  | 124 | 155 | 185 | 216 | 247 | 277 | 308 | 338 |
| 5                            | 5   | 36  | 64  | 95  | 125 | 156 | 186 | 217 | 248 | 278 | 309 | 339 |
| 6                            | 6   | 37  | 65  | 96  | 126 | 157 | 187 | 218 | 249 | 279 | 310 | 340 |
| 7                            | 7   | 38  | 66  | 97  | 127 | 158 | 188 | 219 | 250 | 280 | 311 | 341 |
| 8                            | 8   | 39  | 67  | 98  | 128 | 159 | 189 | 220 | 251 | 281 | 312 | 342 |
| 9                            | 9   | 40  | 68  | 99  | 129 | 160 | 190 | 221 | 252 | 282 | 313 | 343 |
| 10                           | 10  | 41  | 69  | 100 | 130 | 161 | 191 | 222 | 253 | 283 | 314 | 344 |
| 11                           | 11  | 42  | 70  | 101 | 131 | 162 | 192 | 223 | 254 | 284 | 315 | 345 |
| 12                           | 12  | 43  | 71  | 102 | 132 | 163 | 193 | 224 | 255 | 285 | 316 | 346 |
| 13                           | 13  | 44  | 72  | 103 | 133 | 164 | 194 | 225 | 256 | 286 | 317 | 347 |
| 14                           | 14  | 45  | 73  | 104 | 134 | 165 | 195 | 226 | 257 | 287 | 318 | 348 |
| 15                           | 15  | 46  | 74  | 105 | 135 | 166 | 196 | 227 | 258 | 288 | 319 | 349 |
| 16                           | 16  | 47  | 75  | 106 | 136 | 167 | 197 | 228 | 259 | 289 | 320 | 350 |
| 17                           | 17  | 48  | 76  | 107 | 137 | 168 | 198 | 229 | 260 | 290 | 321 | 351 |
| 18                           | 18  | 49  | 77  | 108 | 138 | 169 | 199 | 230 | 261 | 291 | 322 | 352 |
| 19                           | 19  | 50  | 78  | 109 | 139 | 170 | 200 | 231 | 262 | 292 | 323 | 353 |
| 20                           | 20  | 51  | 79  | 110 | 140 | 171 | 201 | 232 | 263 | 293 | 324 | 354 |
| 21                           | 21  | 52  | 80  | 111 | 141 | 172 | 202 | 233 | 264 | 294 | 325 | 355 |
| 22                           | 22  | 53  | 81  | 112 | 142 | 173 | 203 | 234 | 265 | 295 | 326 | 356 |
| 23                           | 23  | 54  | 82  | 113 | 143 | 174 | 204 | 235 | 266 | 296 | 327 | 357 |
| 24                           | 24  | 55  | 83  | 114 | 144 | 175 | 205 | 236 | 267 | 297 | 328 | 358 |
| 25                           | 25  | 56  | 84  | 115 | 145 | 176 | 206 | 237 | 268 | 298 | 329 | 359 |
| 26                           | 26  | 57  | 85  | 116 | 146 | 177 | 207 | 238 | 269 | 299 | 330 | 360 |
| 27                           | 27  | 58  | 86  | 117 | 147 | 178 | 208 | 239 | 270 | 300 | 331 | 361 |
| 28                           | 28  | 59  | 87  | 118 | 148 | 179 | 209 | 240 | 271 | 301 | 332 | 362 |
| 29                           | 29  |     | 88  | 119 | 149 | 180 | 210 | 241 | 272 | 302 | 333 | 363 |
| 30                           | 30  |     | 89  | 120 | 150 | 181 | 211 | 242 | 273 | 303 | 334 | 364 |
| 31                           | 31  |     | 90  |     | 151 |     | 212 | 243 |     | 304 |     | 365 |

Suspect Date Range:  
January 9, 2014 - October 28, 2014

009

301



