

**SUBJECT: Campaign Improvement of Broom Badger Hydraulic Oil Cooler Wiring**

**DATE: 10/15/2014**

**NUMBER: SB-0148**

**TO: All Dealer Principals, Service Managers, and Parts Managers**

**PURPOSE:**

Certain Broom Badger sweepers require a modification of the hydraulic oil cooler fan wiring harness. Failure of the oil cooler fan to operate may cause overheating of the hydraulic components and malfunction of related circuits.

**SPECIAL TOOLS:**

Electrical wire cut, splice, strip, crimp and solder tools

**UNITS TO SERVICE:**

Broom Badger CH-165 - CH-265

**PARTS REQUIRED:**

**WARRANTY COVERAGE:**

1 hour

Part No.	Qty.	Description
152953-91	1	Fan and Sensor Harness Upgrade (Includes Instructions)

**PROCEDURE:**

On some Broom Badger units the wiring for the hydraulic cooler fan and the temperature sensor on the hydraulic cooler were incorrectly installed and could result in a malfunction of the hydraulic cooling and temperature protection system. See FIGURE 12 and FIGURE 14 for component locations and schematic modifications.

FSO kit 152953-91 includes harness and parts for two separate circuits:

- Replace existing cooler fan circuit breaker with a fuse and install dedicated fan cooler ground harness.
- Modify the Cooler Hydraulic Temperature shut-down circuit with a new connector.

**152953-91 Electrical Installation**

**Install new fused motor 12V power circuit**

1. Raise the hopper and install the hopper stop pins. (FIGURE 1)
2. Open the battery box (NOTE: Battery box will be located along the chassis frame rail but may be found on either side of the sweeper depending upon the factory installation.). (FIGURE 2)
3. Disconnect both positive battery cables from the battery terminal to ensure that there is no power in the system.
4. Locate the cooler fan connector near the fan. FIGURE 3. Cut the wires near each side of the connector and remove it. Temporarily remove the P clip to allow room to work on the wiring.

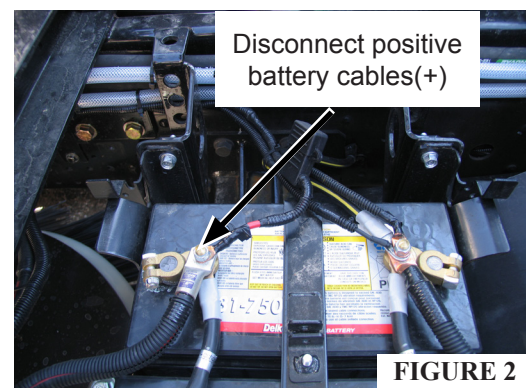
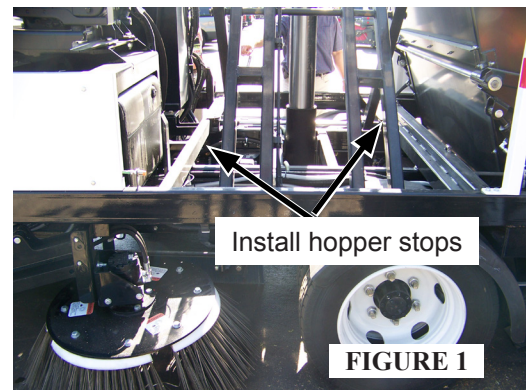

### Install Cooler Fan Connector (Fan Pigtail)

5. Strip 1/4" of insulation from the wires coming from the fan and the wires on the new fan connector assembly 153003 from the kit.
6. Slide a short length of heat shrink over the red wire and install the crimp-connect butt splice. Solder the red wire from the fan to the red wire on the fan connector 153003 and cover the joint with heat shrink tubing.
7. Slide a short length of heat shrink over the black wire and install the crimp-connect butt splice. Solder the black wire from the fan to the black wire on the fan connector 153003 and cover the joint with heat shrink tubing.

### Install New Cooler Fan (power/ground) Harness

8. New 12V power and dedicated cooler motor ground will be installed.
9. Run the long ground wire (black) from connector assembly 153003 along other harnesses down to the frame ground point under the engine and use cable ties to hold it in place. FIGURE 4
10. Open grey electrical box and remove vertical and horizontal conduit covers. (FIGURE 5)
11. Lift Relay #2 from the base and remove the blue wire. (FIGURE 6)
12. Remove the blue wire from the relay base and remove entire blue wire between the relay 2 and breaker F2 from grey box. New wire and fuse will be installed. (FIGURE 6)
13. Remove top nut from stud on breaker F2 (load circuit) and remove the blue wire from top stud. (FIGURE 6)
14. Install fuse holder assembly onto the stud in the grey box as shown. (FIGURE 7)

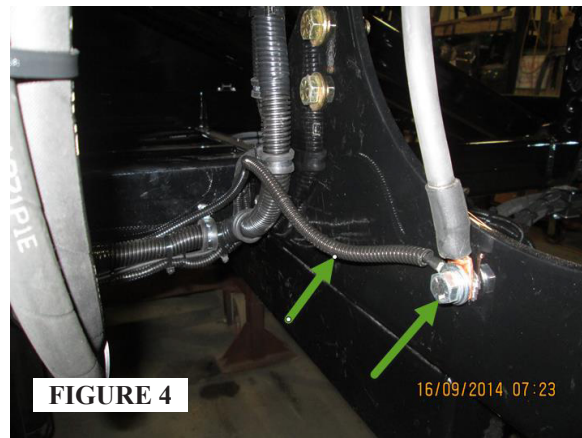

15. Run the new wire with the quick connect to the #2 relay base and install it where the original blue wire was removed. (FIGURE 6)
16. Run the blue wire with ring terminal from the fuse holder through the conduit channels and out and connect it onto the lower stud (12V hot) on breaker F1. (FIGURE 6) NOTE: Breaker F2 will no longer be functional for the cooler fan circuit.
17. Route wires neatly in the conduit channels and tie down as required.
18. Re-install the conduit covers in the electrical box.
19. Slide a short length of heat shrink over the blue wire (fuse-to fan wire previously cut) and install the crimp-connect butt splice. Solder the blue wire from the fan harness connector 153003 to the blue wire from relay #2 in the grey electrical box, and cover the joint with heat shrink. The blue wire from relay #2 was cut off near the old fan connector.

**Connect the New Cooler Motor Connector**

20. Plug the two connectors together and route wires neatly and securely. (FIGURE 9)
21. Re-install the P clip.

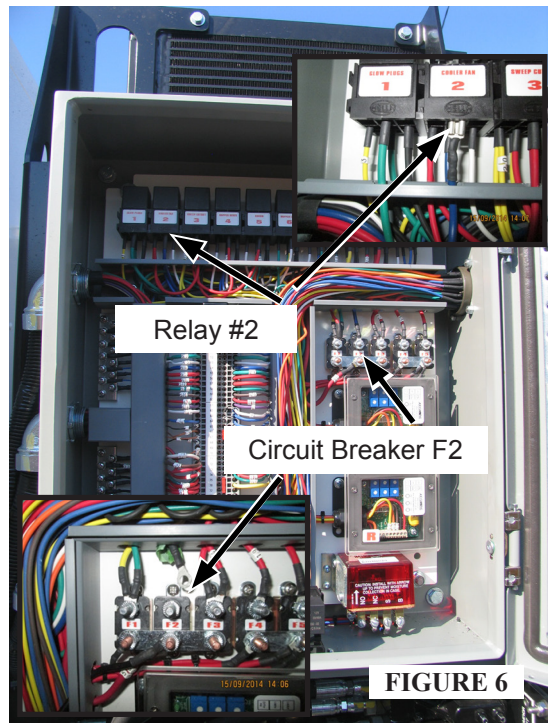

FIGURE 6

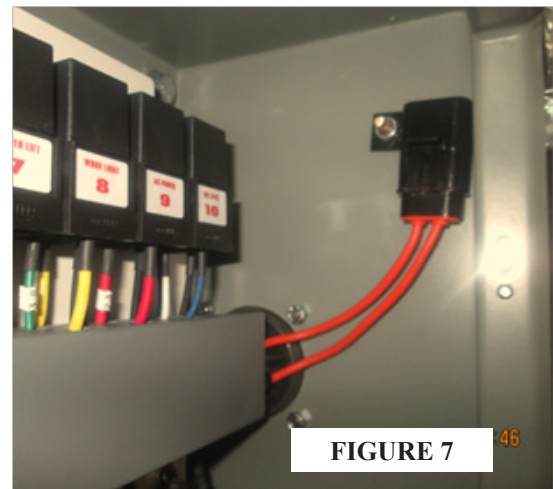
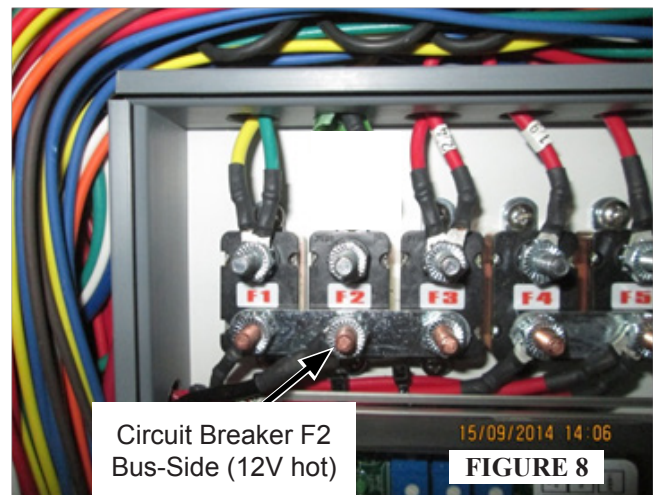

FIGURE 7



FIGURE 5



Circuit Breaker F2 Bus-Side (12V hot)

FIGURE 8

**REPLACE THE TEMPERATURE SENSOR HARNESS CONNECTOR (See FIGURE 12 For Connector Assembly Detail)**

22. Locate the temperature sensor connector near the temperature sensor located on the hydraulic cooler and cut the wires on each side of the connector. (FIGURE 9 & 11)
23. Strip ¼" of insulation from the sensor wires.

**Harness Connector FIGURE 12**

24. Slide a short length of heat shrink over the red wire (previously cut) and install the crimp-connect butt splice. Solder the red wire from the harness to the red wire from the new connector and cover the joint with heat shrink.
25. Slide a short length of heat shrink over the black wire (previously cut) and install the crimp-connect butt splice. Solder the black wire from the harness to the black wire from the new connector and cover the joint with heat shrink.

**Sensor Connector pigtail FIGURE 12**

26. Slide a short length of heat shrink over both of the black wires (previously cut) and install crimp-connect butt splices. Solder the black wires from the sensor to the black wires from the new connector and cover the joint with heat shrink.
27. Plug the two connectors together and route wires neatly and securely.
28. Re-connect the battery cables.
29. Ensure that the installation is complete. (FIGURE 13)
30. During sweep operation, the hydraulic oil cooler fan should operate as the hydraulic oil reaches 120 degrees. Overheating of the hydraulic oil will cause the engine to be shut down by the Murphy engine protection system.

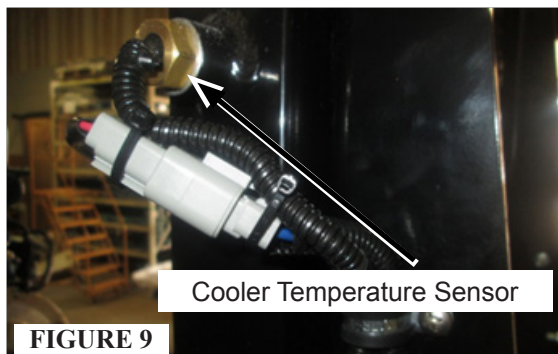

**FIGURE 9**

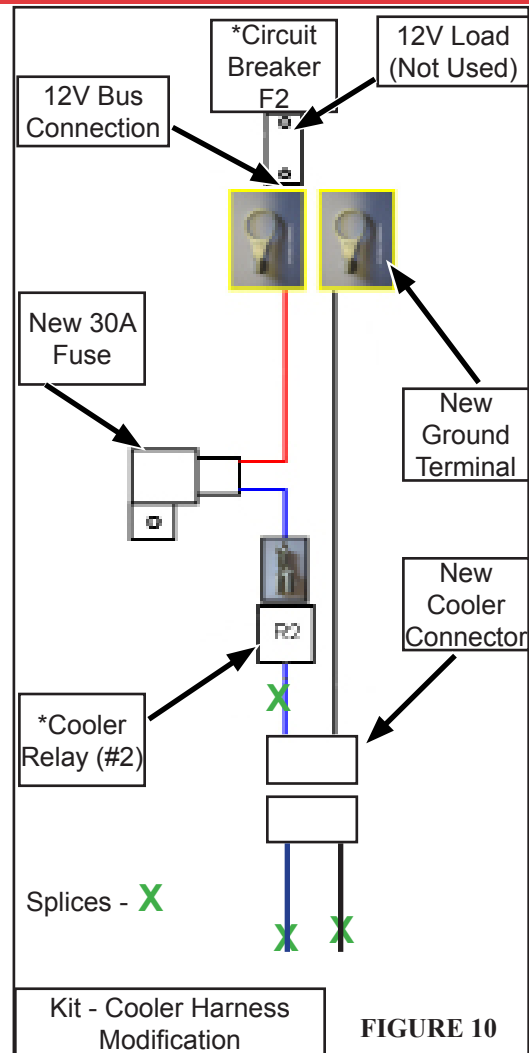

**FIGURE 10**

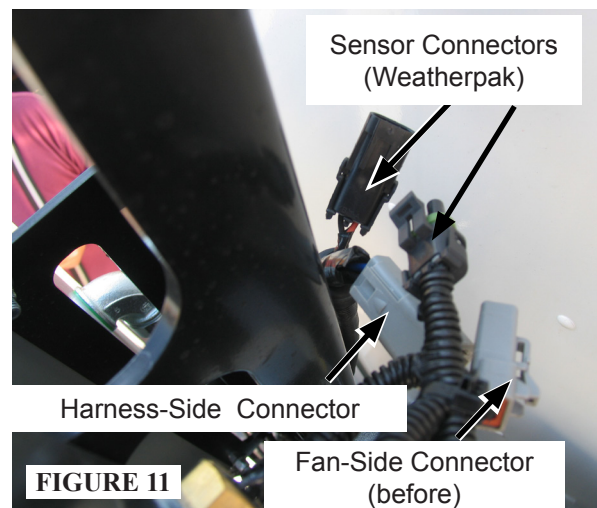

**FIGURE 11**

RevNo	Revision note	Date	ECN	Checked
A	INITIAL RELEASE	10/6/14	600	RS

ITEM NO	PART NUMBER	DESCRIPTION	QTY	MANUFACTURER #
1	152961	ASM - FUSE HOLDER	1	-
2	153003	ASM - FAN PLUG	1	-
3	153002	ASM - SENSOR PLUG	1	-
4	152561	M6 FLAT WASHER	1	-
5	153012	M6 NYLON NUT	1	-
6	-	SHRINK TUBE	7	-

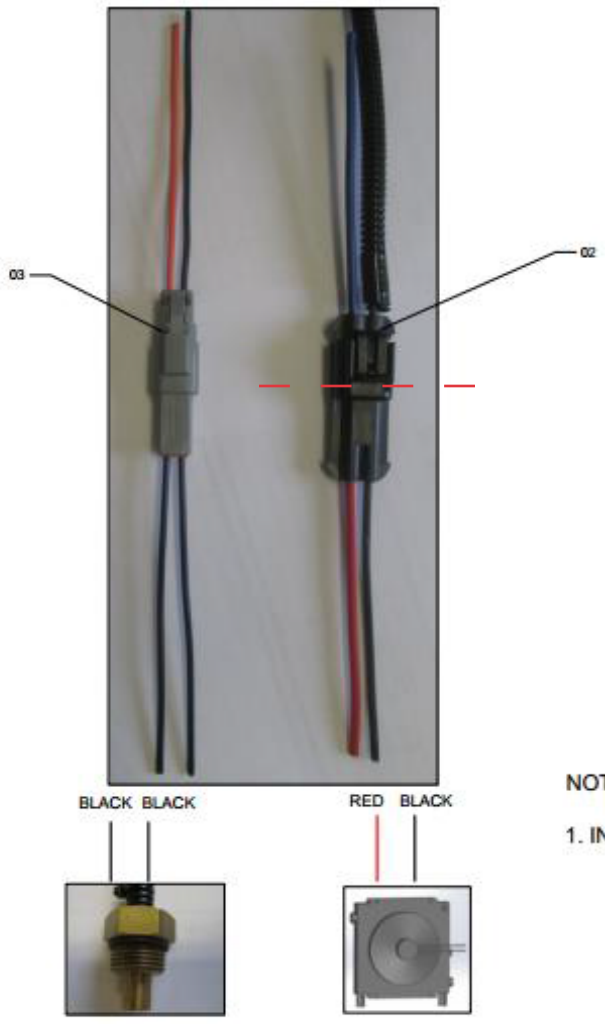
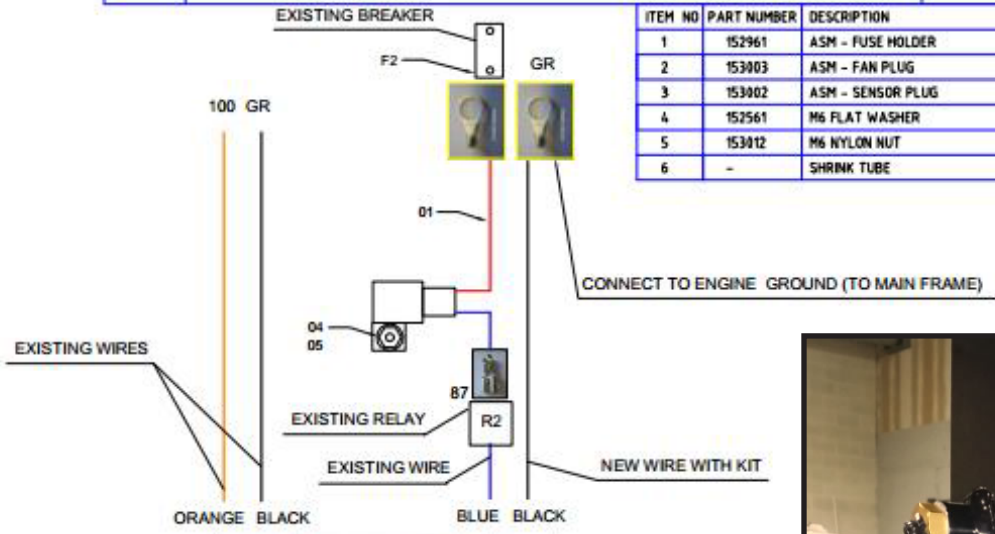

OIL COOLER TEMP. SENSOR. OIL COOLER FAN



FIGURE 13

- NOTES:  
 1. INSTALL ON UNIT USING INSTRUCTIONS 152965.

<small>PROPERTY AND CONFIDENTIALITY</small> THE INFORMATION CONTAINED IN THIS DRAWING IS THE SOLE PROPERTY OF CHALLENGER MFG. ANY REPRODUCTION IN PART OR AS A WHOLE WITHOUT THE WRITTEN PERMISSION OF CHALLENGER MFG. IS PROHIBITED.	Designed by H.K.	Checked by -	Weight XXX	File name .	Date 11/09/14	Scale 1:1	
	TOLERANCE UNLESS OTHERWISE SPECIFIED FINISH:            mm            inches FRACTIONAL: UP TO 2"   mm            inches ANGULARITY:           mm            inches CONCENTRICITY:           mm            inches PERPENDICULARITY:           mm            inches THREAD: EXTERNAL           mm            inches INTERNAL           mm            inches		CHALLENGER MFG		KIT - CONNECTORS, FAN/SENSOR		
					152953	Size 0	Sheet 1/1

FIGURE 12

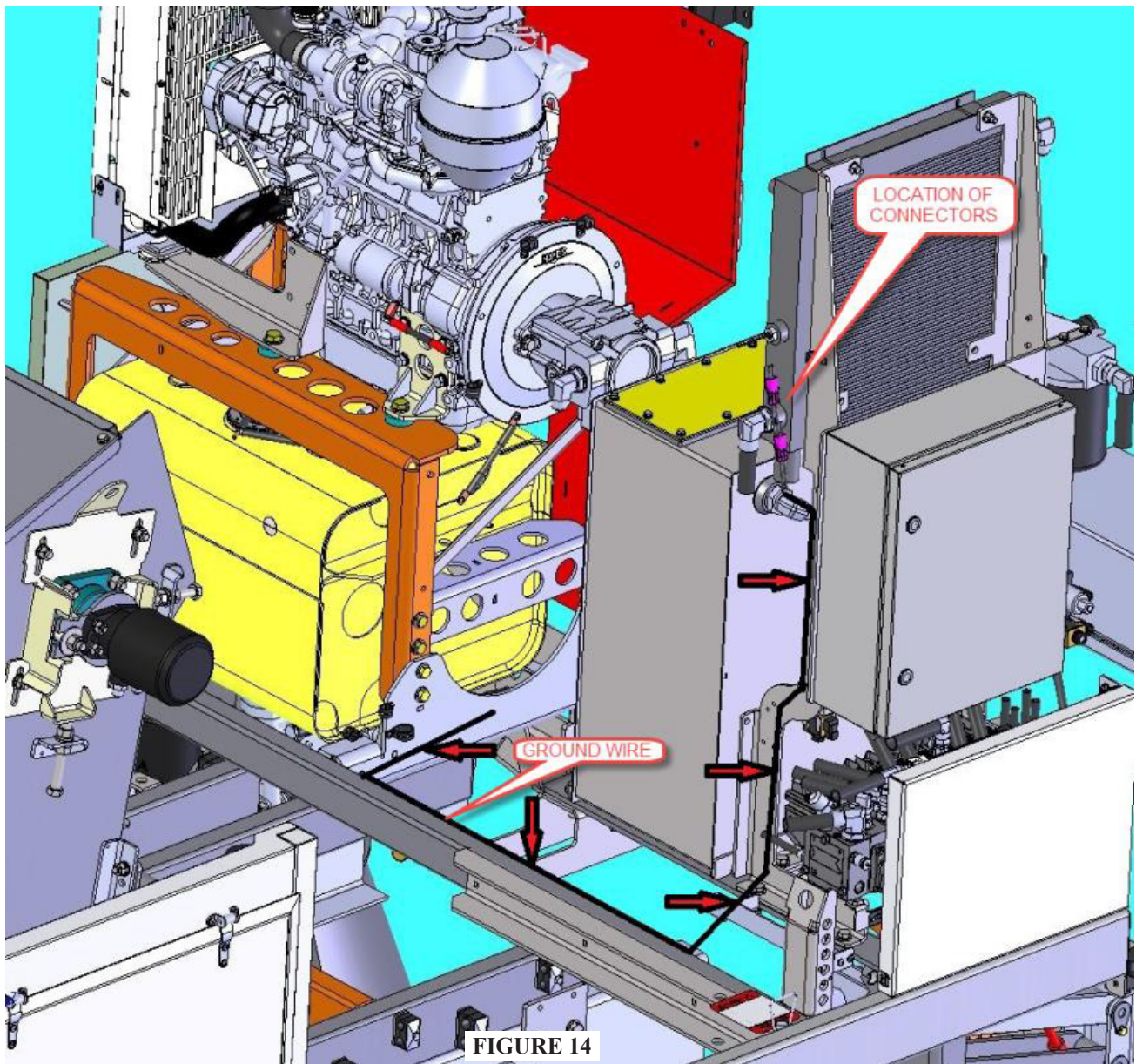

FIGURE 14

---

### Warranty Coverage and Claim Submittal

The ESG dealer should submit a claim for warranty.

Use the following information when submitting a warranty claim:

**CAUSAL PART: 110022-91**

To create the FAULT CODE, click ELECTRICAL (04), click HARNESSSES / CONNECTORS (021), click FAN AND SENSOR HARNESS (1086).

In the FAULT FOUND drop down list, select DESIGN UPGRADE.

In the CAUSED BY drop down list, select Product Improvement.

To enter the Service procedures, perform the following:

For **INSTALLED PART # 152953-91**, select ELECTRICAL (04), select HARNESSSES / CONNECTORS (021), select FAN AND SENSOR HARNESS (1086), and then select INSTALL (01).

**Standard Repair Time (SRT) of 1 hrs and 0 min is allowed.**