



Mercedes-Benz

Campaign No. 2014120002, December 2014

TO: ALL MERCEDES-BENZ CENTERS

SUBJECT: **Models 166 (ML) Model Year 2015, 204.9 (GLK), 212 (E-Class) Model Years 2014-2015 with Engine 651 (4-Cylinder Diesel)**
Replace Timing Chain Tensioner Sealing Ring

Daimler AG (DAG) has determined that on approximately 4,314 Model Year 2015 ML 250 BlueTEC, Model Year 2014-2015 GLK 250 BlueTEC and E 250 BlueTEC vehicles, the chain tensioner sealing ring on the 4 cylinder diesel engine may have experienced variations in material tolerances during a certain production period. Such sealing rings may exhibit an increased settling behavior, which could negatively influence the pretensioning force. Over time, this might lead to loosening of the chain tensioner, as well as an ineffective sealing ring seal for engine oil. As a consequence, leakage of engine oil onto the road might pose a threat to following traffic. Should the oil leakage reach a certain amount the engine might stall. Oil leakage in the presence of an ignition source could also increase the risk of a potential fire. An authorized Mercedes-Benz dealer will replace the chain tensioner sealing ring

Attached is a sample copy of a letter which owners of the affected vehicles will receive.

Prior to performing this Recall Campaign:

- Please check VMI to determine if the vehicle is involved in the Campaign and if it has been previously repaired.
- Please review the entire Recall Campaign bulletin and follow the repair procedure exactly as described.

Please note that Recall Campaigns **do not expire** and may also be performed on a vehicle with a vehicle status indicator.

Approximately 4,314 vehicles are involved.

Order No. S-SC-2014120002

This bulletin has been created and maintained in accordance with MBUSA-SLP S423QH001, Document and Data Control, and MBUSA-SLP S424HH001, Control of Quality Records.

Procedure



Figure 1

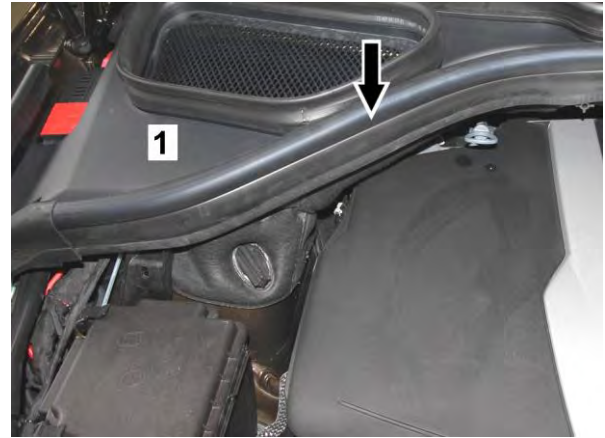

Figure 2

1. For models 204.9/212: Remove engine cover (1, Figure 1) then proceed to step 3.
For model 166 proceed to step 2.
2. Remove right partition wall section:
 - Remove hood seal (arrow, Figure 2) on right side of engine compartment and place to one side.
 - Remove right rear engine cover (1).

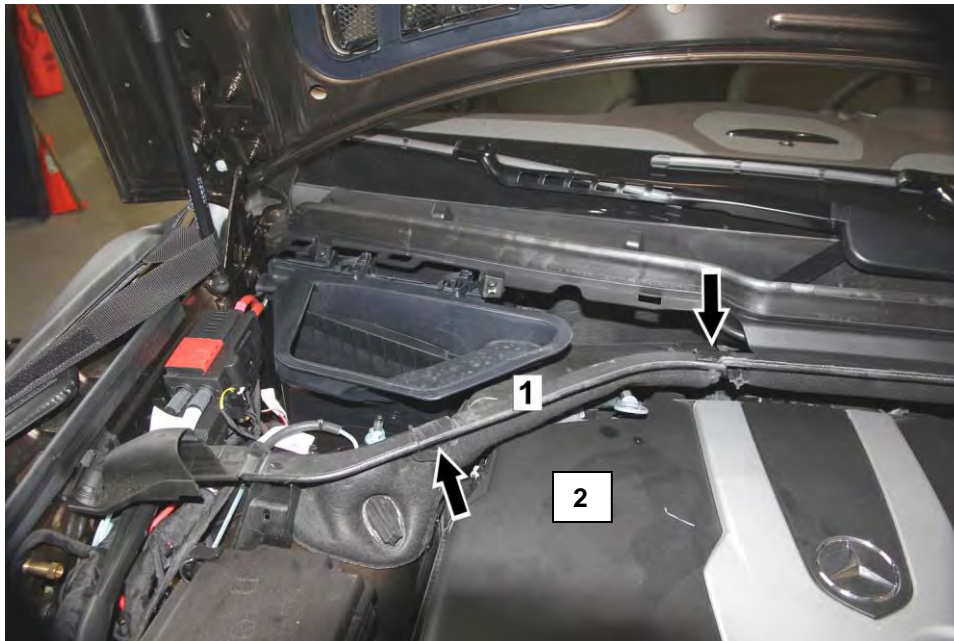

Figure 3

- Remove 2 screws (arrows, Figure 3).
- Remove partition wall section (1, Figure 3).
- Remove engine cover (2, Figure 3)
- Proceed to step 3.

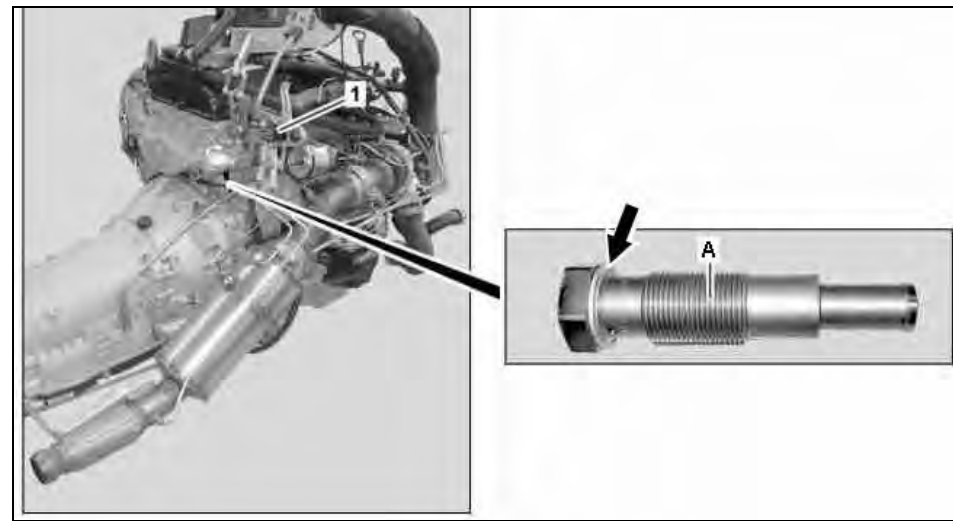

Figure 4

3. Remove air filter housing; refer to WIS: AR09.10-P-1150CD.

i Note (regarding referenced WIS instructions):

Be careful not to damage seal on intake air duct connected to turbo or damage to turbo may occur.

4. Remove cover in front of poly V-belt; refer to WIS: AR13.20-P-0001OMA. Perform step 3 only.

5. Set piston for cylinder 1 to top dead center (TDC); Refer to WIS: AR05.20-P-6010CD. Perform step 5.2 only.

i Note:

- Use special tool 651 589 00 40 00 to turn vibration damper pulley.
- Turn vibration damper pulley in direction of rotation only.

6. Replace timing chain tensioner sealing ring (arrow, Figure 4); refer to WIS: AR05.10-P-7800CD.

i Note (regarding referenced WIS instructions):

Do not replace timing chain tensioner, remove and reinstall only.

i Note:

Refer to steps below regarding supplemental information for installing new sealing ring on timing chain tensioner:

- Unfasten the sealing ring (2, Figure 5) using a small screwdriver (arrow), pry off and take off.

i Note: Do not damage the sealing surface of the chain tensioner (1) in the process. Leaks can occur otherwise.

- Check sealing surface on cylinder head and chain tensioner (1) for damage and check for any adhering residues, and clean if necessary.

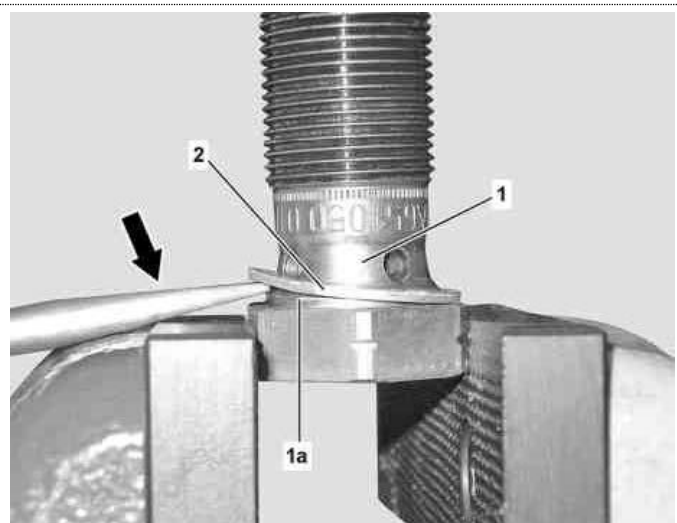

Figure 5

- Check oil feed bore for chain tensioner (1, Figure 5) for fouling and foreign objects and clean if necessary.
- Lay on a new sealing ring (2, Figure 5) by hand and pre-center with slight pressure on the centering collar (1a, Figure 5).
i Press on sealing ring (2, Figure 5) but not completely; the sealing ring (2, Figure 5) assumes the correct location through screwing in.
 Do not use any additional lubricant or sealant.

IMPORTANT:

Torque timing chain tensioner to 80 Nm. WIS torque specification will be revised in future WIS release.

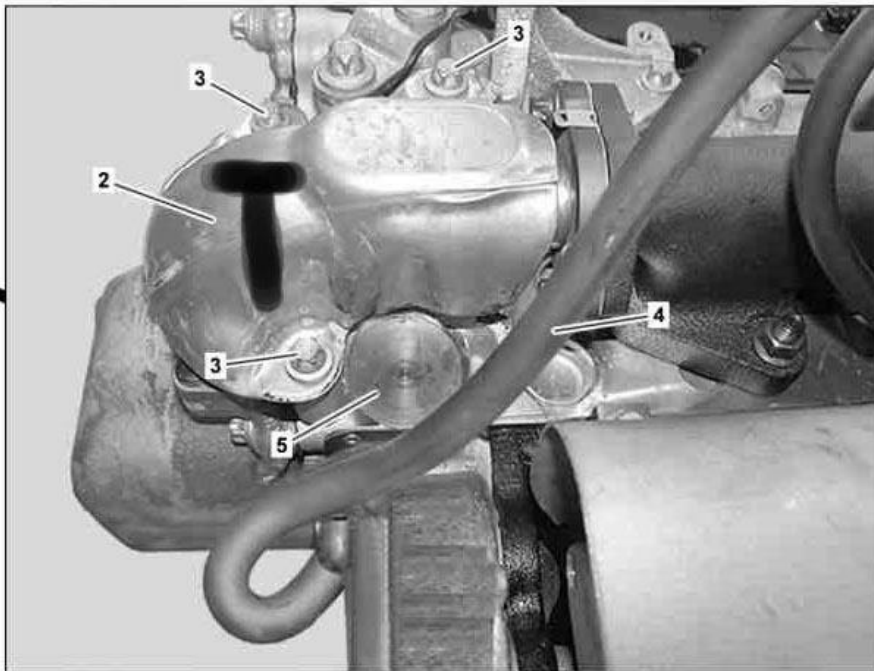

Figure 6

- Mark heat shield (2, Figure 6) with the letter "T" (using permanent marker) to indicate campaign has been performed.
7. Reassemble in reverse order.
 8. Start engine and check for leaks.

i **Note** (regarding WIS documents referenced in this Procedure):

Replacement of parts not listed in the parts table of this Procedure are not claimable under this campaign. If replacement of additional part(s) is necessary, check coverage prior to submitting under warranty.

Primary Parts Information

Qty.	Part Name	Part Number	Estimated Replacement Rate
1	Timing chain sealing ring	A 651 997 01 45	100%

i **Note:**

- Please be aware that only the part number(s) referenced in the Campaign Bulletin is/are approved for use to repair the vehicle. Repairs performed using any other part(s) will not have been performed in accordance with the campaign. Accordingly, warranty claims submitted with reference to an improper part number(s) will be denied.
- The following allowable labor operation should be used when submitting a warranty claim for this repair:

Warranty Information

Operation: Replace sealing ring on chain tensioner (02-8807).

Damage Code	Operation Number	Labor Time (hrs.)
05 930 03 7	02-8807	1.1 (models: 204.9/212)
		1.4 (model 166)

i **Note**

Operation Number labor times are subject to change.



Mercedes-Benz

Mercedes-Benz USA, LLC

Gareth Joyce

Vice President
Customer Services

IMPORTANT SAFETY RECALL 2014 120002
This notice applies to your vehicle,
Timing Chain Tensioner Gasket
NHTSA Recall # 14V762

December, 2014

Dear Mercedes-Benz Owner,

This notice is sent to you in accordance with the requirements of the National Traffic and Motor Vehicle Safety Act.

Daimler AG (DAG), the manufacturer of Mercedes-Benz vehicles, has decided that a defect which relates to motor vehicle safety exists in the timing chain tensioner gasket of Model Year 2015 ML 250 BlueTEC, Model Year 2014-2015 GLK 250 BlueTEC and E 250 BlueTEC vehicles during a certain production period. Our records indicate that your vehicle is included in the affected population of vehicles.

WE SENT YOU THIS NOTICE BECAUSE WE ARE CONCERNED ABOUT YOUR SAFETY.

The chain tensioner gasket on the 4-cylinder diesel engine may have experienced variations in material tolerances during a certain production period. Over time, this might lead to loosening of the chain tensioner, as well as an ineffective gasket seal for engine oil. As a consequence, leakage of engine oil onto the road might pose a threat to following traffic. Should the oil leakage reach a certain amount, the engine might stall. Oil leakage in the presence of an ignition source could also increase the risk of a potential fire. An authorized Mercedes-Benz dealer will replace the timing chain tensioner gasket.

This service will be provided free of charge. We are dedicated to always delivering the Best or Nothing – and respect for your time is a top priority. While the minimum repair time is approximately one and a half hours, your dealer can provide you with a better estimate of the overall time for this service visit. As a matter of normal service process, an authorized Mercedes-Benz dealer will also check for other repair measures which might be applicable to your vehicle and this may increase the required working time.

For additional information and to schedule an appointment please contact **MERCEDES-BENZ OF ANYTOWN, 201-555-1234** or another authorized dealer, at your earliest convenience. To locate additional authorized dealers see www.MBUSA.com/dealerlocator.

Please mention you are scheduling an appointment to replace your timing chain tensioner gasket under Recall Campaign # 2014 120002. You may be asked for your 17-digit Vehicle Identification Number (VIN) which, for your convenience, is located above your name at the top of this letter.

In the event that you are no longer the vehicle owner, or have had a change of address, please complete the reverse side and return the updated information in the enclosed envelope. If this is a leased vehicle and the lessor and registered owner receive this notice, please forward this information by first class mail to the lessee within 10 days to comply with federal regulations.

Should you have any questions or encounter any difficulty regarding this Recall Campaign please contact an authorized Mercedes-Benz dealer. If for any reason a dealer is unable to remedy your situation, we are always happy to hear from you. Please contact us at 1-(800) FOR-MERCEDES (1-800-367-6372). A new vehicle identification number (VIN)-based recall lookup tool, on our MBUSA.com website, now offers a search function that will indicate whether a vehicle has been subject to a safety recall, and whether that vehicle has had the free remedy performed. See www.MBUSA.com/recall.

If an authorized Mercedes-Benz dealer or MBUSA fails or is unable to perform this service without charge within 60 days, pursuant to law 49 U.S.C. Chapter 301, you may submit a complaint to the Administrator, National Highway Traffic Safety Administration, 1200 New Jersey Avenue, S.E., Washington, D.C. 20590 or call the toll-free Auto Safety Hotline at 1-888-327-4236 (TTY 1-800-424-9153); or go to <http://www.safercar.gov>.

We regret any inconvenience this situation may cause you.

Sincerely,

Mercedes-Benz USA, LLC
One Mercedes Drive
P.O. Box 350
Montvale, NJ 07645-0350
Phone 1-800-FOR-MERCEDES (1-800-367-6372)
Fax (201) 476-6211
www.MBUSA.com

IMPORTANT

IF FOR ANY REASON YOU DO NOT NOW OWN THIS VEHICLE OR HAVE A CHANGE OF ADDRESS, PLEASE COMPLETE THE SECTION BELOW, PLACE IN THE ENCLOSED ENVELOPE, AND DROP IN ANY MAIL BOX. IF POSSIBLE, PROVIDE THE NAME AND ADDRESS OF THE PRESENT OWNER SO THAT WE MAY CONTACT THEM.

- SCRAPPED
- STOLEN
- OTHER _____
- SOLD _____ I HAVE SOLD THE VEHICLE TO:
- MY NEW ADDRESS IS:

NAME _____

STREET _____ **APT.** _____

CITY _____ **STATE** _____ **ZIP** _____

PHONE _____

THANK YOU FOR YOUR COOPERATION



Mercedes-Benz

Mercedes-Benz USA, LLC

Gareth Joyce

Vice President
Customer Services

IMPORTANT SAFETY RECALL 2014 120002
This notice applies to your vehicle,
Timing Chain Tensioner Gasket
NHTSA Recall # 14V762

December, 2014

Dear Mercedes-Benz Owner,

This notice is sent to you in accordance with the requirements of the National Traffic and Motor Vehicle Safety Act.

Daimler AG (DAG), the manufacturer of Mercedes-Benz vehicles, has decided that a defect which relates to motor vehicle safety exists in the timing chain tensioner gasket of Model Year 2015 ML 250 BlueTEC, Model Year 2014-2015 GLK 250 BlueTEC and E 250 BlueTEC vehicles during a certain production period. Our records indicate that your vehicle is included in the affected population of vehicles.

WE SENT YOU THIS NOTICE BECAUSE WE ARE CONCERNED ABOUT YOUR SAFETY.

The chain tensioner gasket on the 4-cylinder diesel engine may have experienced variations in material tolerances during a certain production period. Over time, this might lead to loosening of the chain tensioner, as well as an ineffective gasket seal for engine oil. As a consequence, leakage of engine oil onto the road might pose a threat to following traffic. Should the oil leakage reach a certain amount, the engine might stall. Oil leakage in the presence of an ignition source could also increase the risk of a potential fire. An authorized Mercedes-Benz dealer will replace the timing chain tensioner gasket.

This service will be provided free of charge. We are dedicated to always delivering the Best or Nothing – and respect for your time is a top priority. While the minimum repair time is approximately one and a half hours, your dealer can provide you with a better estimate of the overall time for this service visit. As a matter of normal service process, an authorized Mercedes-Benz dealer will also check for other repair measures which might be applicable to your vehicle and this may increase the required working time.

For additional information and to schedule an appointment please contact **MERCEDES-BENZ OF ANYTOWN, 201-555-1234** or another authorized dealer, at your earliest convenience. To locate additional authorized dealers see www.MBUSA.com/dealerlocator.

Please mention you are scheduling an appointment to replace your timing chain tensioner gasket under Recall Campaign # 2014 120002. You may be asked for your 17-digit Vehicle Identification Number (VIN) which, for your convenience, is located above your name at the top of this letter.

In the event that you are no longer the vehicle owner, or have had a change of address, please complete the reverse side and return the updated information in the enclosed envelope. If this is a leased vehicle and the lessor and registered owner receive this notice, please forward this information by first class mail to the lessee within 10 days to comply with federal regulations.

Should you have any questions or encounter any difficulty regarding this Recall Campaign please contact an authorized Mercedes-Benz dealer. If for any reason a dealer is unable to remedy your situation, we are always happy to hear from you. Please contact us at 1-(800) FOR-MERCEDES (1-800-367-6372). A new vehicle identification number (VIN)-based recall lookup tool, on our MBUSA.com website, now offers a search function that will indicate whether a vehicle has been subject to a safety recall, and whether that vehicle has had the free remedy performed. See www.MBUSA.com/recall.

If an authorized Mercedes-Benz dealer or MBUSA fails or is unable to perform this service without charge within 60 days, pursuant to law 49 U.S.C. Chapter 301, you may submit a complaint to the Administrator, National Highway Traffic Safety Administration, 1200 New Jersey Avenue, S.E., Washington, D.C. 20590 or call the toll-free Auto Safety Hotline at 1-888-327-4236 (TTY 1-800-424-9153); or go to <http://www.safercar.gov>.

We regret any inconvenience this situation may cause you.

Sincerely,

Mercedes-Benz USA, LLC
One Mercedes Drive
P.O. Box 350
Montvale, NJ 07645-0350
Phone 1-800-FOR-MERCEDES (1-800-367-6372)
Fax (201) 476-6211
www.MBUSA.com



Mercedes-Benz – are registered trademarks of Daimler AG, Stuttgart, Germany

IMPORTANT

IF FOR ANY REASON YOU DO NOT NOW OWN THIS VEHICLE OR HAVE A CHANGE OF ADDRESS, PLEASE COMPLETE THE SECTION BELOW, PLACE IN THE ENCLOSED ENVELOPE, AND DROP IN ANY MAIL BOX. IF POSSIBLE, PROVIDE THE NAME AND ADDRESS OF THE PRESENT OWNER SO THAT WE MAY CONTACT THEM.

SCRAPPED

STOLEN

OTHER _____

SOLD _____ **I HAVE SOLD THE VEHICLE TO:**

MY NEW ADDRESS IS:

NAME _____

STREET _____

APT. _____

CITY _____

STATE _____

ZIP _____

PHONE _____

THANK YOU FOR YOUR COOPERATION