

TECHNICAL BULLETIN

J047NAS1
10 NOV 2014



© Jaguar Land Rover North America, LLC

NOTE: The information in Technical Bulletins is intended for use by trained, professional Technicians with the knowledge, tools, and equipment required to do the job properly and safely. It informs these Technicians of conditions that may occur on some vehicles, or provides information that could assist in proper vehicle service. The procedures should not be performed by 'do-it-yourselfers'. If you are not a Retailer, do not assume that a condition described affects your vehicle. Contact an authorized Jaguar service facility to determine whether this bulletin applies to a specific vehicle.

SECTION: 501-20B

Safety Recall: Seatbelt Tension Sensor Connector Wiring

AFFECTED VEHICLE RANGE:

F-TYPE (X152)

Model Year: 2014-2015
VIN: K00001-K19747

MARKETS:

NAS

CONDITION SUMMARY:

Safety Recall J047 supersedes Update Prior to Sale UPS8014-3b with immediate effect.

Situation: Jaguar Land Rover have identified that on certain 2014-2015 model year F-TYPE (X152) vehicles the seatbelt assembly harness connector which connects the Seatbelt Tension Sensor (STS) to the Occupant Classification Sensor Control Module (OCSCM) may not be correctly wired. The wires are located in the incorrect terminals within the connector.

The main purpose of the OCSCM is to provide the occupant classification sensor with the occupancy status of the passenger seat. The Restraints Control Module (RCM) uses this information and the seatbelt buckle status in the determination of the firing strategy for the passenger restraints.

The main purpose of the STS is to ensure that if a child seat is fitted using the auto-locking seatbelt to restrain it in the passenger seat, the tension exerted on the seatbelt tension sensor indicates that a child seat is fitted. The RCM uses this information and the OCSCM status to determine the firing strategy for the passenger restraints. The occupant classification sensor should determine if the front passenger seat is unoccupied, occupied by a child seat or small person, or occupied by an adult.

In the event that the seatbelt assembly harness STS is wired incorrectly, the occupant classification system will transmit a signal which does not indicate the installation of a child seat or the presence of a small person. In the case of a child seat being fitted, the occupant classification sensor will not disable the passenger airbag, if a small person is present in the passenger seat the Passenger Airbag Deactivation indicator (PADI) will indicate that the seat is not occupied and the Supplementary Restraint System (SRS) will not deploy if required.

In the event of a vehicle crash the passenger side SRS may not provide the required level of occupant protection increasing the risk of occupant injury.

Action: Retailers are required to **HOLD** only affected vehicles that are within your control and refrain from releasing the vehicles for new or used vehicle sale pending completion of the rework action detailed in this Technical Bulletin. Unsold vehicles should have this performed as part of the Pre-Delivery Inspection (PDI) process but **must** have it completed prior to vehicle handover to the customer.

Affected vehicles already in the hands of customers should be updated at the next available opportunity.

PARTS:

No parts required

SPECIAL TOOLS:

Refer to Workshop Manual / Service Instruction for any required tools

WARRANTY:

 **NOTE: Check DDW to ensure that a vehicle is affected by this program prior to undertaking any rework action. Repair procedures are under constant review, and therefore times / prices are subject to change; those quoted here must be taken as guidance only. Refer to TOPIx to obtain the latest repair time. At the time of confirming a booking for vehicle repair, ensure that all outstanding Service Actions are identified to ensure the correct parts are available and adequate workshop time is allocated for repairs to be completed at one visit.**

Warranty claims must be submitted quoting Program Code '**J047**' together with the relevant Option Code from the table. The SRO and part information listed have been included for information only. The Option Code(s) that allows for the drive in / drive out allowance may only be claimed if the vehicle is brought into the workshop for this action alone to be undertaken.

Warranty claims must be submitted for payment within 30 calendar days of completion of the repair.

PROGRAM CODE	OPTION CODE	DESCRIPTION	SRO	TIME (HOURS)	PARTS / SUNDRY CODE	QTY. / VALUE
J047	B	Seat belt tensioner system connector wiring rework	05.10.50	0.50	-	-
J047	C	Seat belt tensioner system connector wiring rework Drive in/drive out	05.10.50 10.10.10	0.50 0.10	- -	- -

Normal Warranty policies and procedures apply

SERVICE INSTRUCTION

 **NOTE: Some variation in the illustrations may occur, but the essential information is always correct.**

-  **WARNING: Allow a period of 10 minutes to elapse after disconnecting the battery before undertaking any work on the Supplementary Restraint System (SRS).**

Disconnect the battery (see TOPIx Workshop Manual, section 414-01).

- Remove the electrical connector cover for the passenger seatbelt tension sensor.

- Release the clips.

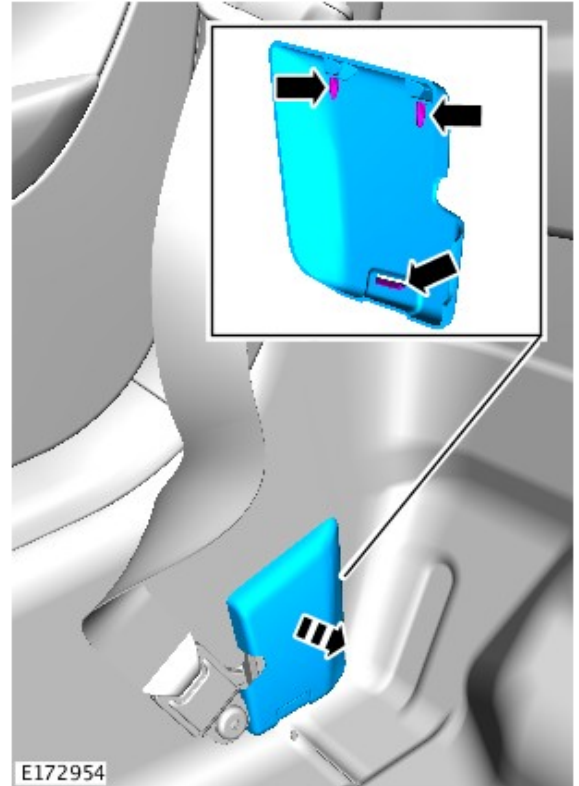

- 3. Release the electrical connector (C3R210) from the bracket.

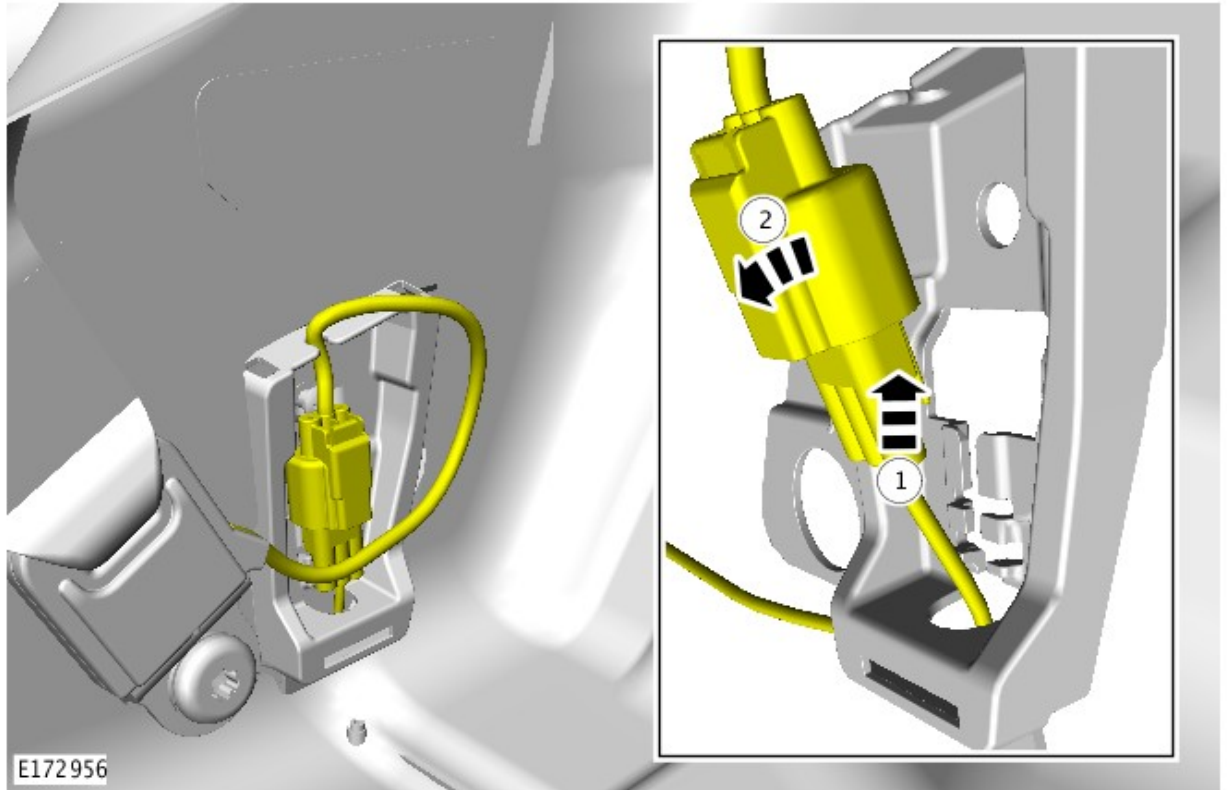

4. At the Seatbelt Tension Sensor side of connector C3R210, check that the electrical connector wires are positioned in the correct pin location as shown.

- If the wires are in the correct position, reverse steps 1-3 and release the vehicle.
- If the wires are not in the correct position, proceed to step 5.

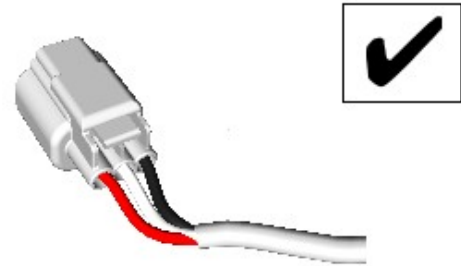
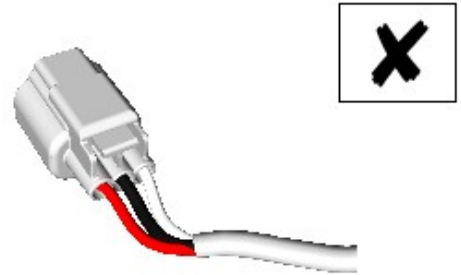

E172955

5. Disconnect the electrical connector.

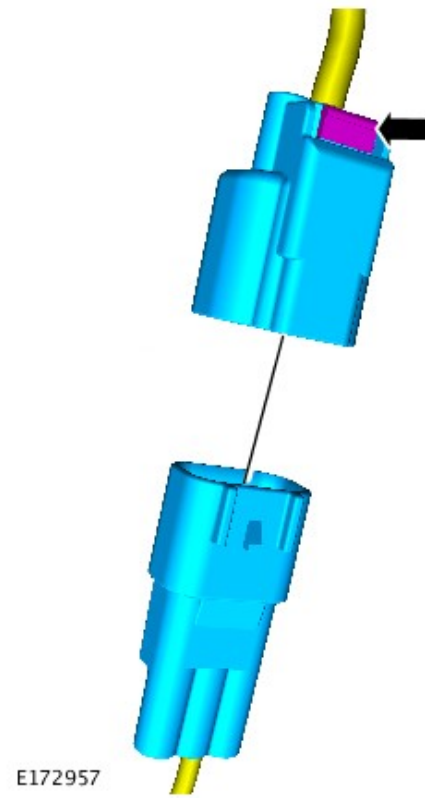

6. Using a suitable tool, remove the anti-backout device from the electrical connector.

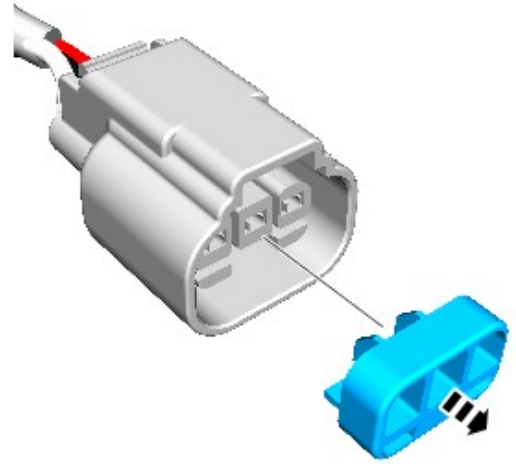

E172958

7. Using special tool 418-595, release the electrical connector.

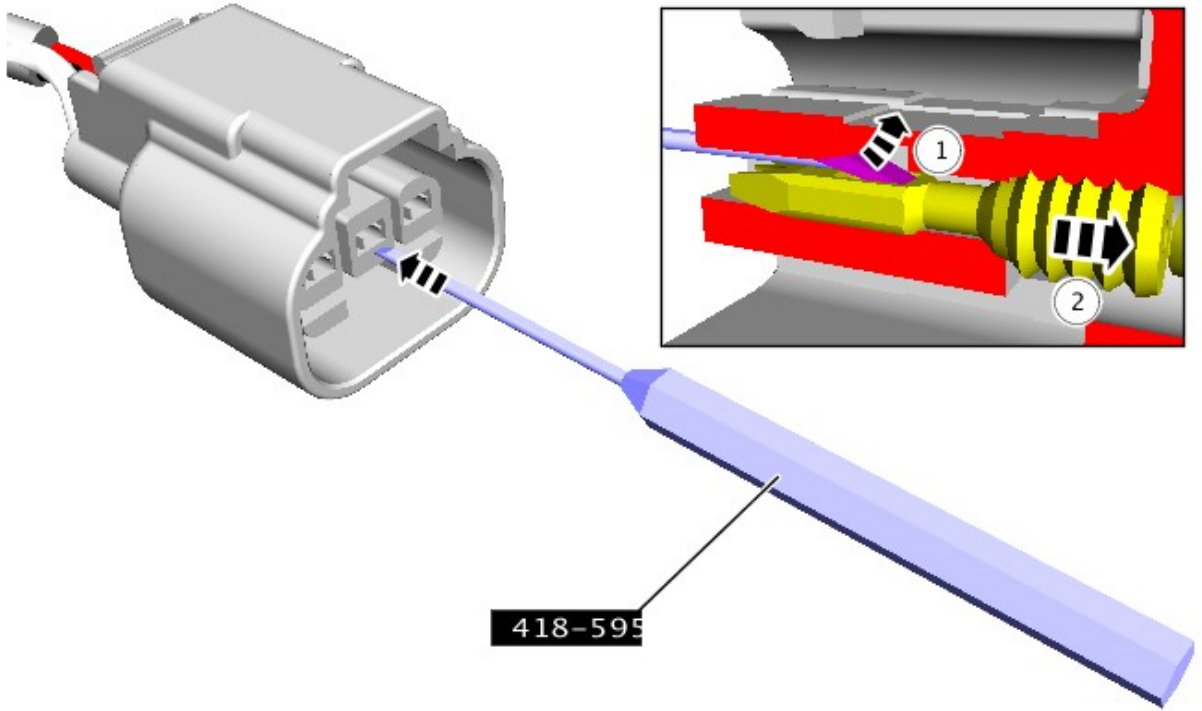

E172960

8. Using special tool 418-595, release the electrical connector.

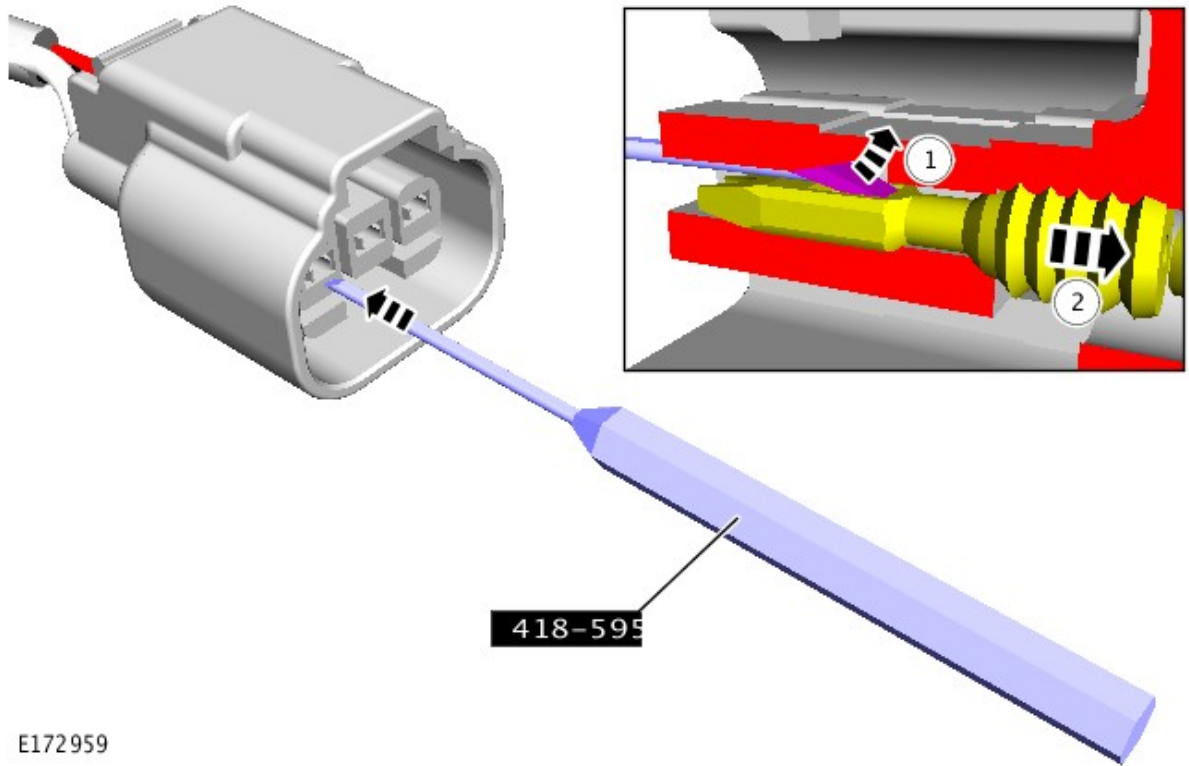

E172959

9. Remove the white wire electrical pin from the electrical connector.

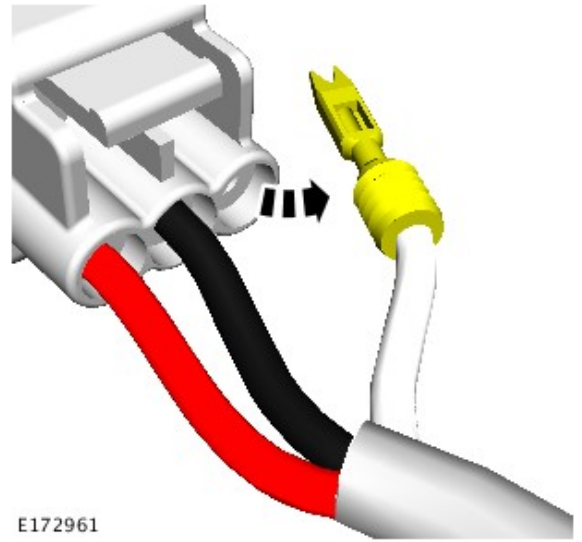

E172961

10. Remove the black wire electrical pin from the electrical connector.

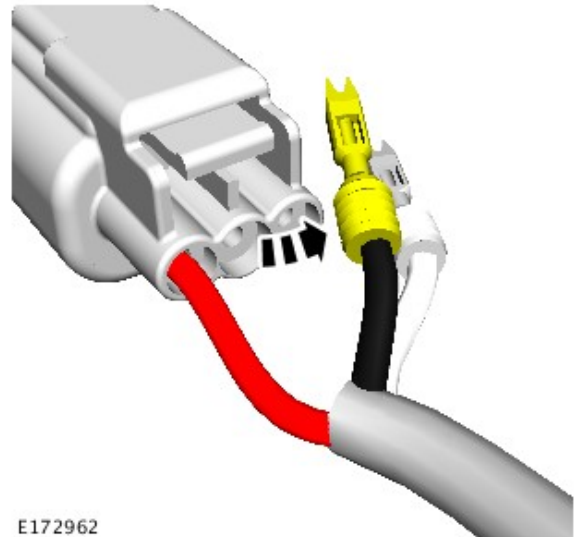

E172962

11. Install the white wire electrical pin into the center socket on the electrical connector.

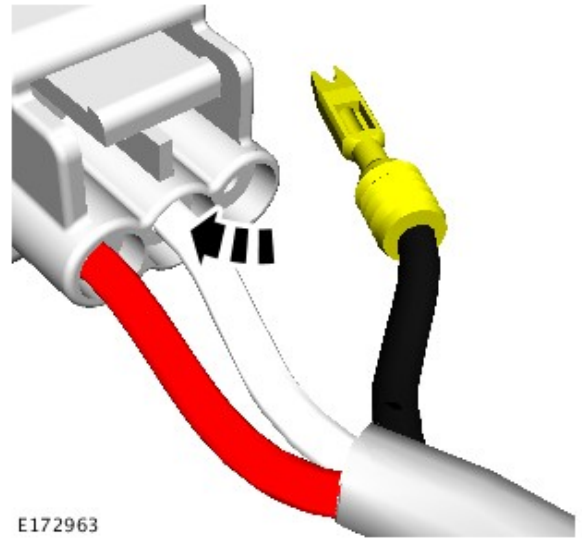

E172963

12. Install the black wire electrical pin into the right-hand-side socket on the electrical connector.

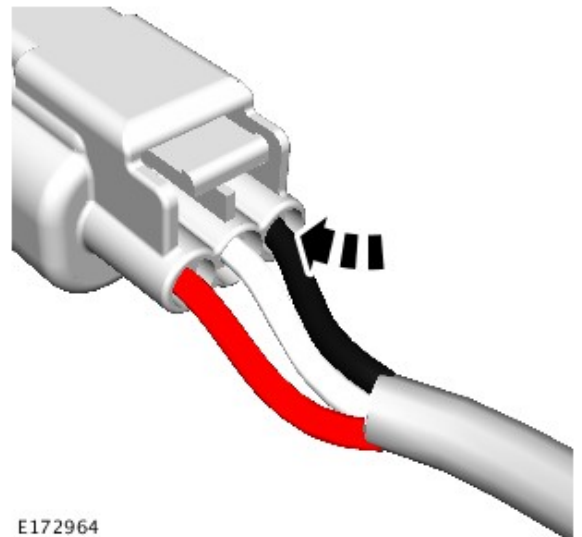

E172964

13. To install, reverse the removal procedure.