



---

**PERFORM THE PROCEDURE OUTLINED IN THIS SERVICE INFORMATION ON ALL AFFECTED VEHICLES BEFORE CUSTOMER DELIVERY OR THE NEXT TIME THEY ARE IN THE SHOP FOR MAINTENANCE OR REPAIRS.**

**BMW centers must ensure recalls are completed after having been notified by BMW of North America, LLC (BMWNA) that a safety-related defect or noncompliance exists in any motor vehicle or item of replacement equipment in the center's possession at the time of notification. In BMW NA's case, this notification would typically be made by the issuance of a recall notification in the form of a Service Information bulletin (SIB) or transmission of a Dealer Communication System (DCS) recall message.**

**Under the National Traffic and Motor Vehicle Safety Act of 1966, as amended, if a recall campaign is announced by BMW NA, centers must ensure that all recalls on new vehicles and new items of replacement equipment are completed BEFORE delivery to the consumer. This means that centers may not legally deliver new motor vehicles or new items of replacement equipment to consumers with an open recall.**

**The Safety Act also prohibits centers from selling or leasing the motor vehicle or item of replacement equipment, unless and until the open recall has been completed BEFORE delivery. This also pertains to vehicles in the Certified Pre-Owned program, and to items of replacement equipment.**

**Finally, BMW centers should not sell or use parts that have been recalled by BMW NA. Please follow the specific instructions provided by BMW NA on the return or disposition of the parts.**

#### **SUBJECT**

**Recall Campaign 14V-650: Replace Left Rear Seat Frame**

#### **MODEL**

F15 (X5)

Produced from September 13, 2014 to September 22, 2014

#### **SITUATION**

The seat belt buckle mount welded to the seat frame is not consistent with BMW requirements.

#### **CAUSE**

Automated welding process

#### **AFFECTED VEHICLES**

This Recall Campaign involves F15 models produced from September 13, 2014 to September 22, 2014.

First check if a Recall Campaign label with a code number **716** is already attached to the B-pillar.

If a code number **716** has been punched out, the Campaign has already been performed and no further action is necessary.

Vehicles which require this Recall Campaign will show it as "Open" when the VIN is checked in the "Service Menu" of DCSnet (Dealer Communication System) or when the key is read in the Key Reader.

#### **CORRECTION**

To improve customer satisfaction and expedite the repair process, the complete left rear seat base will be replaced.

**PROCEDURE**

Replace the left rear seat frame. Refer to the B520114 attachment for ISTA Repair Instruction 52 26...

The illustration below shows the list of preliminary tasks that need to be performed:

|   |   |
|---|---|
| 52 26 ...   | <b>Replacing seat<br/>frame for left rear<br/>seat (Comfort seat)</b>   |
|  | <p><b>Necessary preliminary tasks:</b></p> <ul style="list-style-type: none"> <li>• Disengage <a href="#">Bowden cable for comfort entry</a> on seat mechanism</li> <li>• <a href="#">Remove backrest cover with upholstery</a></li> <li>• Remove <a href="#">rear left lower strap</a></li> <li>• Remove <a href="#">rear middle lower strap</a></li> <li>• Remove <a href="#">microswitch for comfort entry on inner rear seat</a></li> <li>• Remove <a href="#">microswitch for comfort entry on outer rear seat</a></li> <li>• Remove <a href="#">module for seat heating</a></li> <li>• Remove <a href="#">trim on front seat frame</a></li> </ul> |
|   | GRUSB5214-01  |

**PARTS INFORMATION**

We have implemented a VIN-specific parts ordering process for the vehicles involved in this Recall. The part number involved in the repair is blocked from dealer ordering. Please follow the ordering procedure outlined below.

All requests must be emailed to [specialpartsrequest@bmwna.com](mailto:specialpartsrequest@bmwna.com). The email must contain the following information:

Subject line – Seat Frame

Center number and location code where the part should be delivered

Contact Information – Name, Phone number

VIN – Last seven digits (7)

Stock on these parts is limited. Orders will be placed into the system between 10:00am and 6:00pm EST, using the last 7 digits of the VIN as the PO. **All orders will be placed as VOR in the order they are received.** Orders received after local VOR cut off time will be shipped the following day. Multiple requests for the same VIN will be cancelled.

| Part Number     | Description              | Quantity |
|-----------------|--------------------------|----------|
| 52 20 7 385 407 | Comfort seat base - Left | 1        |

#### LABEL INSTRUCTIONS

|  |  |
|--|--|
|  | <p>This Recall Campaign has been assigned code number <b>716</b>. After the vehicle has been checked and/or corrected, obtain a label (SD 92-453) and:</p> <ol style="list-style-type: none"> <li>Emboss your BMW center warranty number in the middle of the label (1);</li> <li>Punch out code number <b>716</b> (2), printed on the label; and</li> <li>Affix the label to the <b>B</b>-pillar as shown.</li> </ol> |
|--|--|

If the vehicle already has a label from a previous Service Action/Recall Campaign, affix the new label next to the old one. Do not affix one label on top of another one, because a number from an underlying label could appear in the punched-out hole of the new label.

#### WARRANTY INFORMATION

Reimbursement for this Recall will be via normal claim entry utilizing the following information:

|                     |                       |
|---------------------|-----------------------|
| <b>Defect Code:</b> | <b>00 52 59 01 00</b> |
|---------------------|-----------------------|

#### Completion before vehicle delivery to the customer or the vehicle is already in the workshop

| Labor Operation: | Labor Allowance: | Description:                             |
|------------------|------------------|--|
| 00 62 829        | Refer to KSD2    | Replace the rear left comfort seat frame |

Labor operation code 00 62 829 is a Plus Labor operation.

#### Completion after vehicle delivery to the customer

| After delivery |               |  |
|----------------|---------------|--|
| 00 62 199      | Refer to KSD2 | Replace the rear left comfort seat frame |

Labor operation code 00 62 199 is a Main Labor operation.

#### ATTACHMENTS

View PDF attachment [B520114 Attachment](#).

**REP-REP-RAF1552-5226X04 Replacing seat frame for left rear seat (Comfort seat)**

|                    |               |                  |  |
|--------------------|---------------|------------------|--|
| VIN:               | XXXXXXX       | Vehicle:         | X'/F15/off-road vehicle/X5<br>50iX/N63/AUT/USA/left-hand drive/2014/09 |
| System<br>Version: | 3.46.30.12830 | Data<br>Version: | R3.46.30.12830   |

52 26 ...

**Replacing seat  
frame for left rear  
seat (Comfort seat)****Necessary preliminary tasks:**

- Disengage [Bowden cable for comfort entry](#) on seat mechanism
- [Remove backrest cover with upholstery](#)
- Remove [rear left lower strap](#)
- Remove [rear middle lower strap](#)
- Remove [microswitch for comfort entry on inner rear seat](#)
- Remove [microswitch for comfort entry on outer rear seat](#)
- Remove [module for seat heating](#)
- Remove [trim on front seat frame](#)

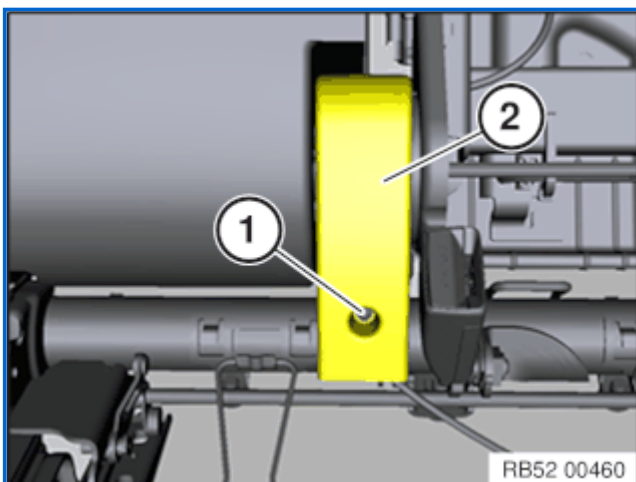

Release screw (1).

Unclip cover (2) towards front.

Release screws (1).

Tightening torque [52 26 27AZ](#).

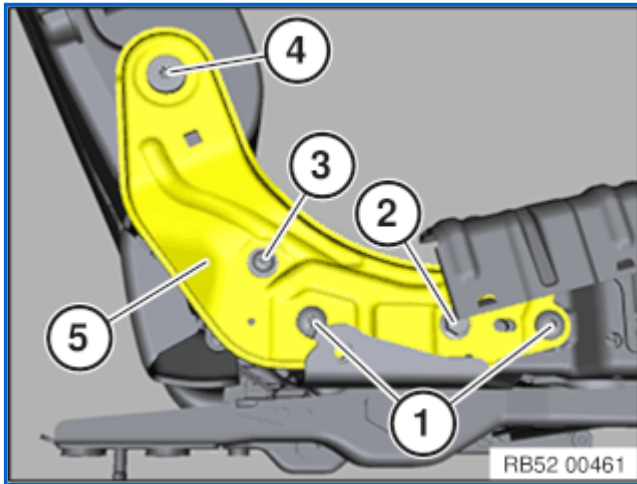

Release screw (2).

Tightening torque [52 26 28AZ](#).

Release screw (3).

Tightening torque [52 26 29AZ](#).

Release screw (4).

Tightening torque [52 26 31AZ](#).

Remove rail (5) to the side.

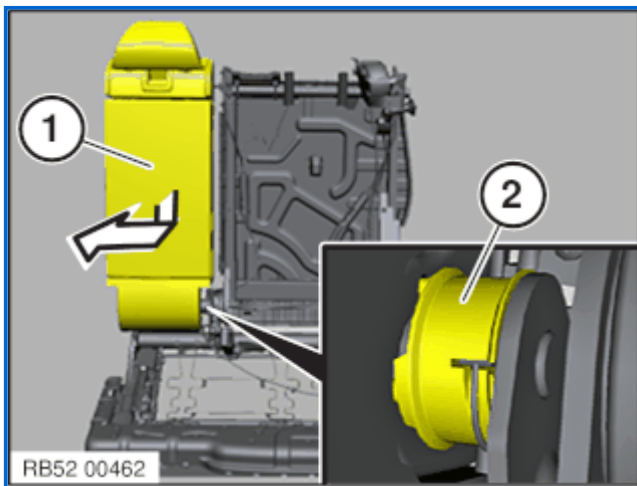

Fold centre backrest (1) forwards and feed out of the seat mechanism to the left.

*Note:*

Mounting for Bowden cable (2) is pre-tensioned.

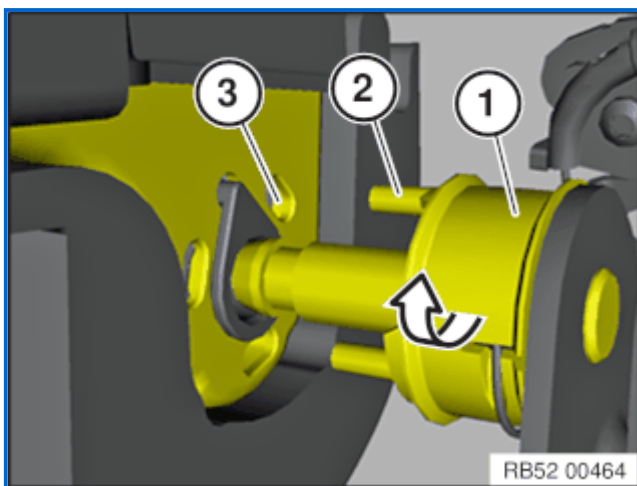

*Installation note:*

Mounting (1) is coded against incorrect assembly.

Twist mounting (1) in direction of arrow until guides (2) are fed into the corresponding openings (3).

*Installation note:*

Pin (1) correctly attached in guide (2).

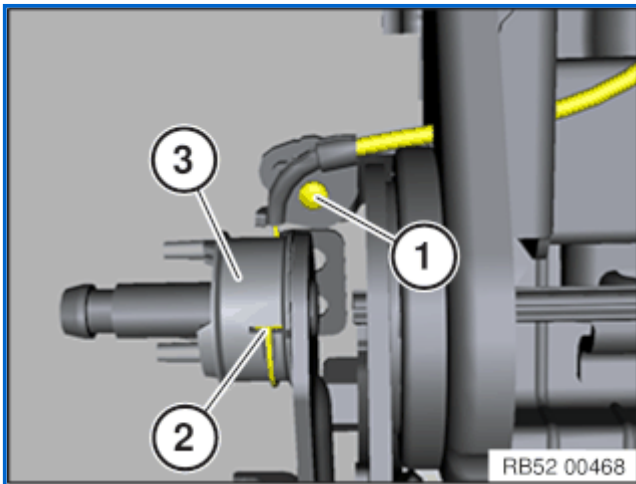
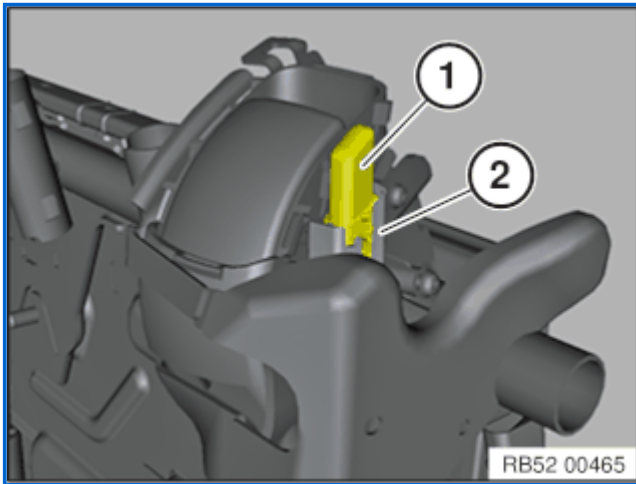

Release screw (1) and detach Bowden cable guide.

Feed Bowden cable (2) out of mounting (3).

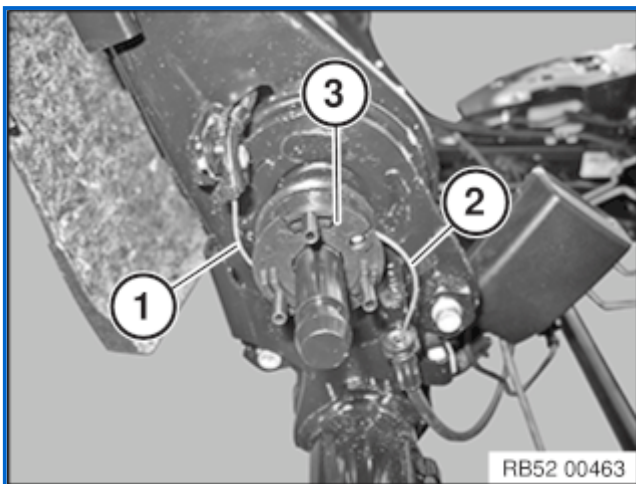

*Installation note:*

Attach Bowden cables (1 and 2) correctly in mounting (3).

Release screws (1).

Tightening torque [52 26 30AZ](#).

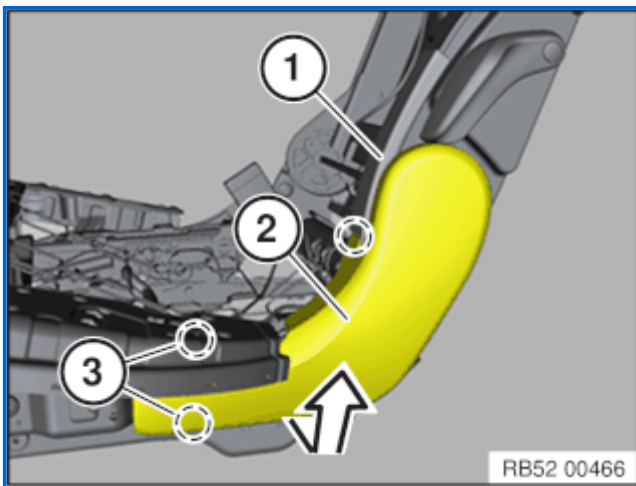
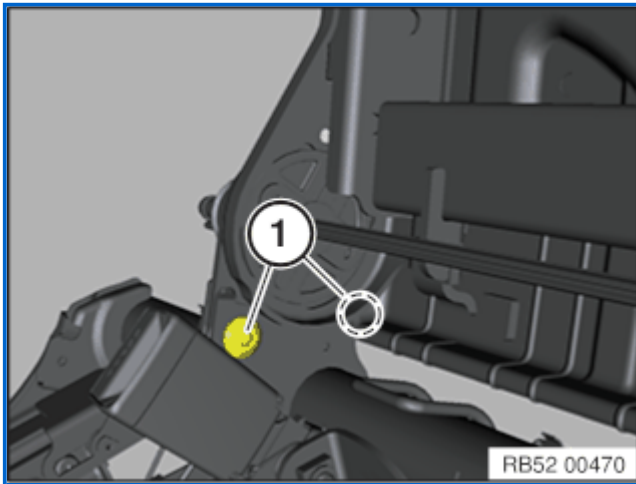

Detach slide (1) from cover (2) in the marked area.

Release screws (3) and feed out the cover (2) upwards and to the rear.

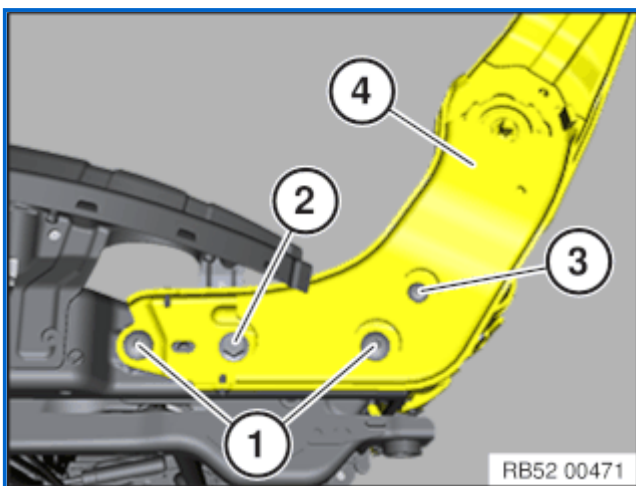

Release screws (1).

Tightening torque [52 26 27AZ](#).

Release screw (2).

Tightening torque [52 26 28AZ](#).

Release screw (3).

Tightening torque [52 26 29AZ](#).

Remove backrest frame (4) from seat mechanism.

**Overview, plug connections:**

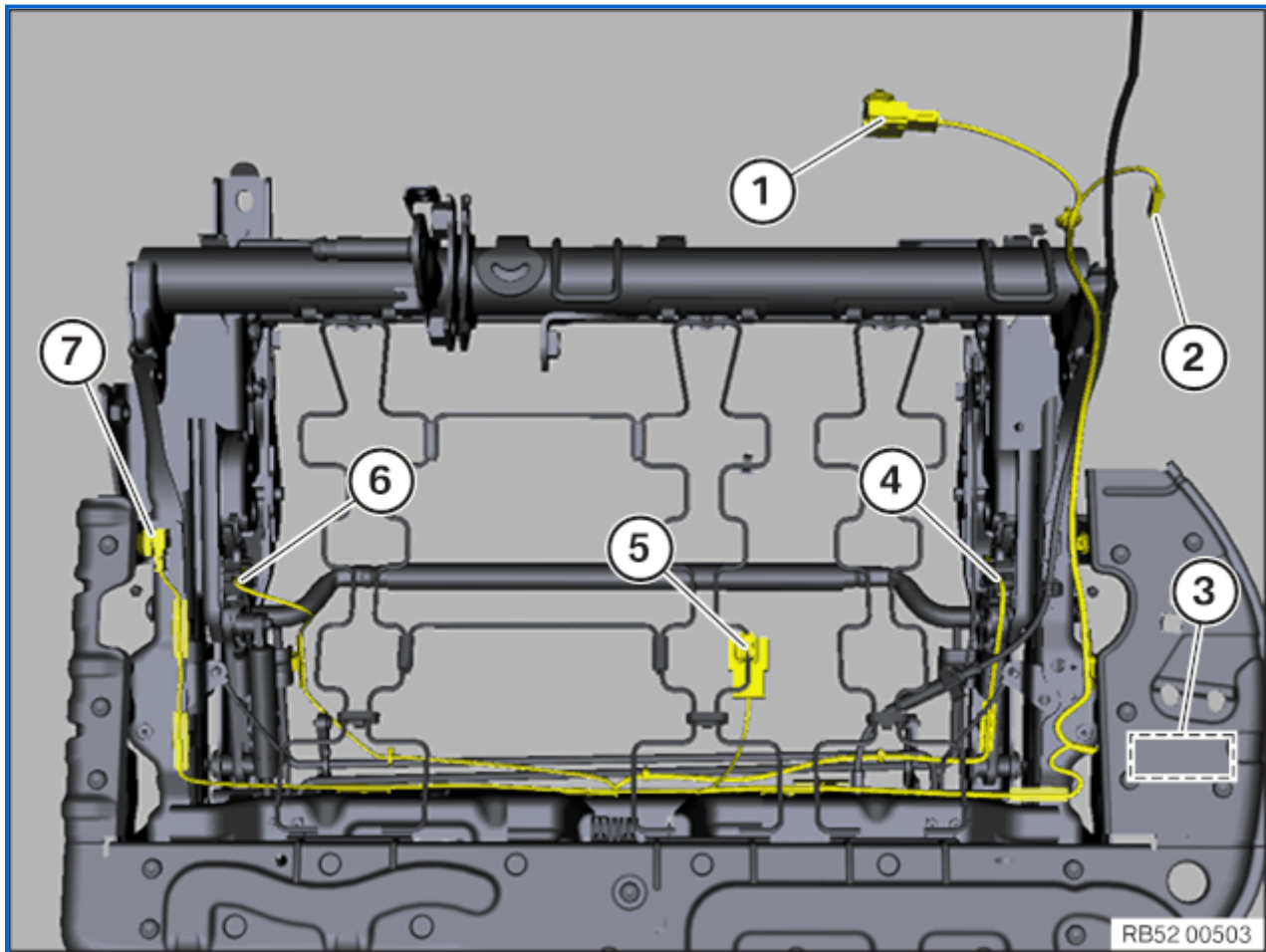

- 1 Seat heating, backrest
- 2 Microswitch, backrest angle adjustment
- 3 Module for seat heating
- 4 Microswitch for comfort entry on outer rear seat
- 5 Seat heating
- 6 Microswitch for comfort entry on inner rear seat
- 7 Seat belt buckle contact