



# Spartan Motors Chassis, Inc.

SERVICE BULLETIN

RSB14-270-006A

NHTSA Id: 14V-623

4/6/2015

Transport Canada Id: TC14-466

**SUBJECT:** Transmission Fluid Cooler

***Bulletin # RSB14-270-006 is superseded by bulletin RSB14-270-006A. Any vehicle repaired under bulletin RSB14-270-006 will not require any additional work.***

**CONDITION:** The transmission fluid cooler, used with transmission retarders, may fail without warning allowing engine coolant to mix with transmission fluid.

**APPLIES TO:** This bulletin applies to emergency response chassis cabs equipped with transmission fluid coolers and retarder transmissions manufactured between April 12, 2007 and November 22, 2011.

**CORRECTION:** Replacement of transmission cooler.

**LABOR ALLOCATION:** 4.0 hrs.

**PARTS NEEDED:**

<u>QTY</u>	<u>Part Number</u>	<u>Description</u>
1	S-2462-001	KIT-SERVICE, TOC 07 C13, ERC

**Kit # S-2462-001 Contains:**

<u>QTY</u>	<u>Part Number</u>	<u>Description</u>
1	0547-TT1-001	CLR-TRANS, FLOATING SHELL /TUBE, ROCORE
1	0549-TT1-001	BRKT-TOC SUPPORT
2	0722-MM5-QQQ04	CONN STR W/VITON O-RING 20F50X-S V0894
2	08130125FH8Y	BOLT 1/2-13 X 1.25 LG. FLG GR8
2	0813FLN8Y	NUT, 1/2-13 FLG LK GR8
4	06160150FH8Y	BOLT 3/8-16 X 1.50 FLG GR8
4	0616FLN8Y	NUT, 3/8-16 FLG LK GR8
1	RSB14-270-006A	DOCUMENT INSTRUCTIONS

**GENERAL INSTRUCTIONS:**

Please thoroughly review entire work procedure before starting work. If there are questions and/or concerns with steps defined in this procedure, contact Spartan Motors Chassis, Inc. Customer & Product Support Group.

All applicable industry safety standards must be followed when performing work identified in this procedure.

Technical Service Bulletins are intended for use by Professional Technicians only. They are written to guide Professional Technicians in performing service to vehicles of product specific nature in conjunction with industry standards. Professional Technicians are appropriately trained on industry standards and have the tools and equipment to perform procedures safely and properly.



**STEP-BY-STEP INSTRUCTIONS:**



Coolant is toxic. Keep away from children and pets. If not reused, dispose of in accordance with local environmental regulations.



Coolant components and other engine components can be very hot if serviced shortly after operation. Serious personal injury can occur if hot components are touched.



Never remove radiator cap while coolant is hot. Remove cap slowly when coolant is at ambient temperature. A sudden release of pressure from a heated cooling system can result in serious personal injury from burst of hot coolant.

1. Tilt cab per instructions on placard.
2. Remove radiator cap.
3. Remove skid plate/re-circulation shield if required for access.
4. Locate drain plug on end of transmission oil cooler for coolant removal. Refer to FIG. 2-1. Radiator drain petcock on driver's side of the radiator is also available.

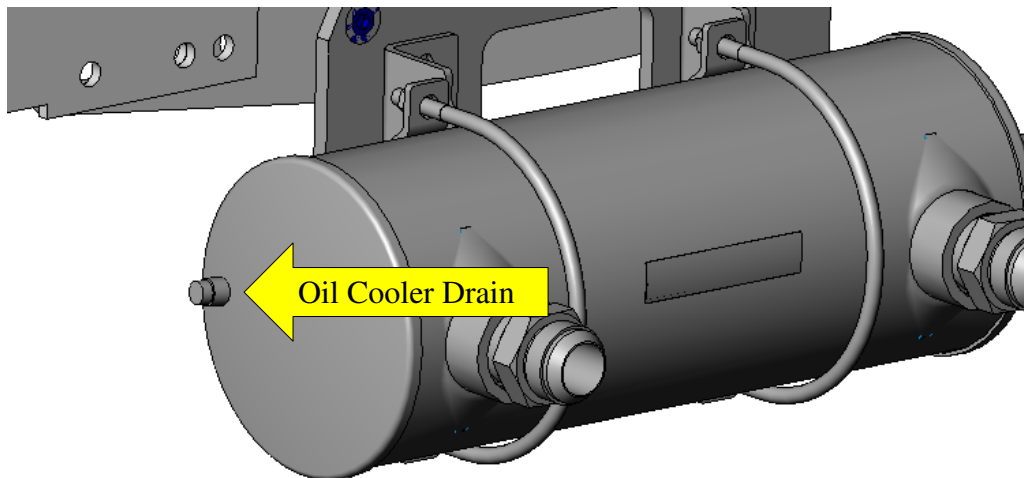

**FIG. 2-1**

5. Drain coolant into a clean approved container. Retain coolant for re-use.
6. Once the coolant has drained completely, place a clean drain pan under the transmission oil cooler.

Technical Service Bulletins are intended for use by Professional Technicians only. They are written to guide Professional Technicians in performing service to vehicles of product specific nature in conjunction with industry standards. Professional Technicians are appropriately trained on industry standards and have the tools and equipment to perform procedures safely and properly.



7. Remove the hose clamps and slide the 90° silicone elbows off of the transmission cooler and drain completely. Retain coolant for re-use.
8. Place an approved drain pan under the transmission fluid lines and remove lines from cooler. Refer to FIG. 3-1. Note the ports each transmission line goes to for reassembly. Allow to drain completely and dispose of transmission fluid in accordance with local regulations.

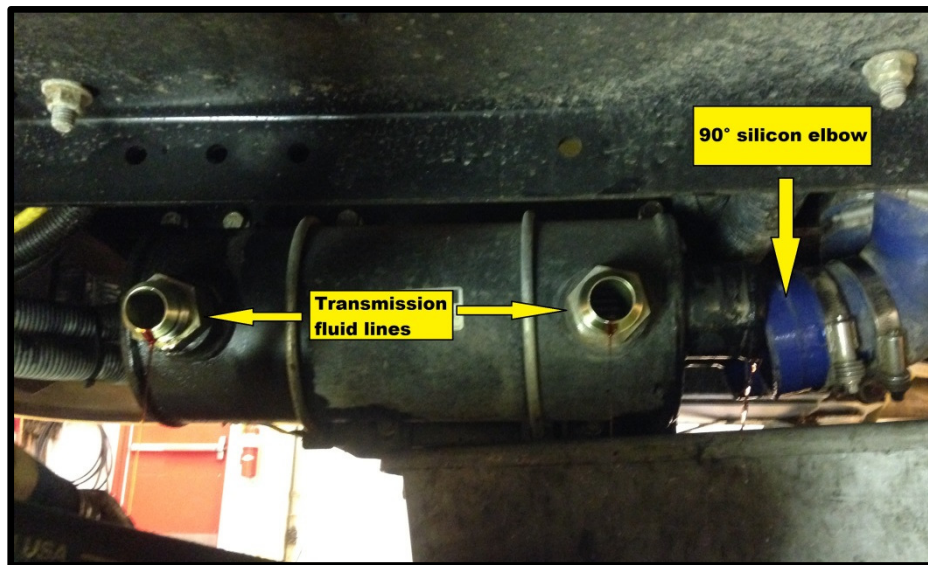

**FIG. 3-1**

**CAUTION**

Transmission cooler is heavy; ensure it is properly supported before removal.

9. Remove two (2), 1/2" fasteners securing the transmission oil cooler bracket to the cross member.
10. Remove bracket from the old cooler and retain for re-use.
11. Lay removed transmission oil cooler next to new floating bundle oil cooler. Line them up by the transmission ports. The mounting brackets on the new cooler will need to be orientated to match those on the removed cooler. Refer to FIG. 4-1.

Technical Service Bulletins are intended for use by Professional Technicians only. They are written to guide Professional Technicians in performing service to vehicles of product specific nature in conjunction with industry standards. Professional Technicians are appropriately trained on industry standards and have the tools and equipment to perform procedures safely and properly.

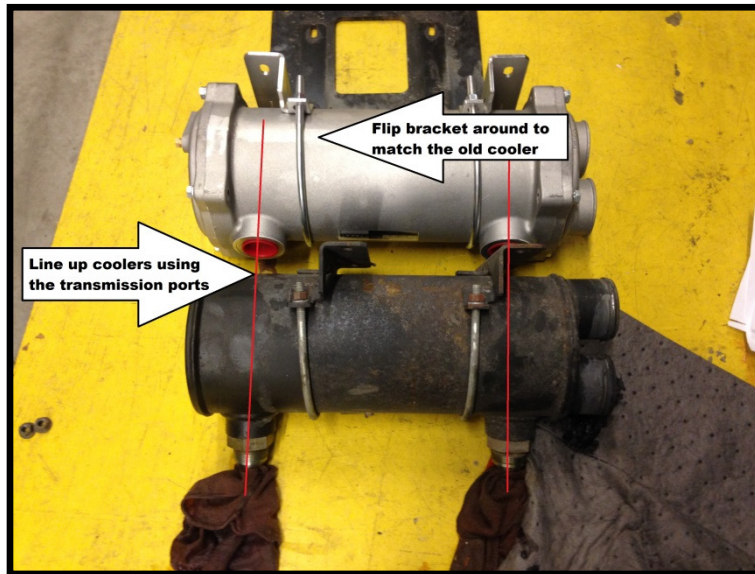

**FIG. 4-1**

12. The hose barb on the new floating bundle is shorter and 3/4" of hose will need to be cut off of each silicone sleeve. Refer to FIG. 4-2. Additionally, only one of the hose clamps will be reused for each hose. Properly dispose of remaining two clamps.

**CAUTION**

Ensure hose is cut straight or the tubes will not seal properly.

**FIG. 4-2**

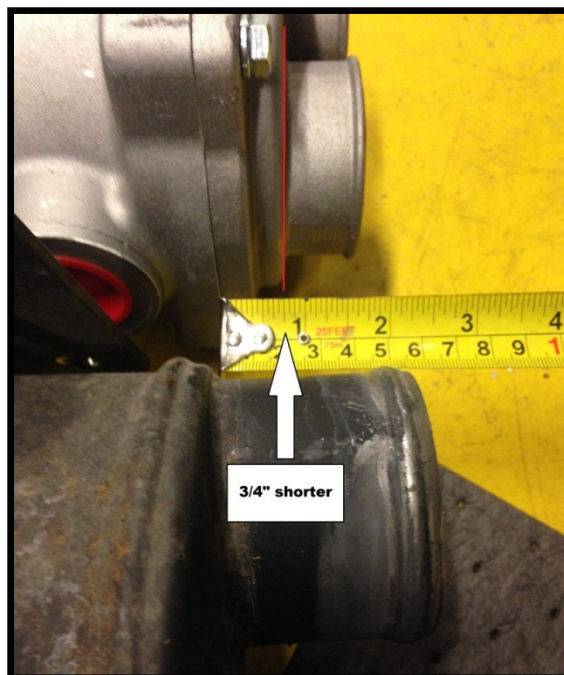

Technical Service Bulletins are intended for use by Professional Technicians only. They are written to guide Professional Technicians in performing service to vehicles of product specific nature in conjunction with industry standards. Professional Technicians are appropriately trained on industry standards and have the tools and equipment to perform procedures safely and properly.



13. Install the transmission oil cooler and brackets to the cross member. Refer to FIG. 5-1 and 5-2. Assemble parts leaving the hardware initially loose to aid in proper final positioning.

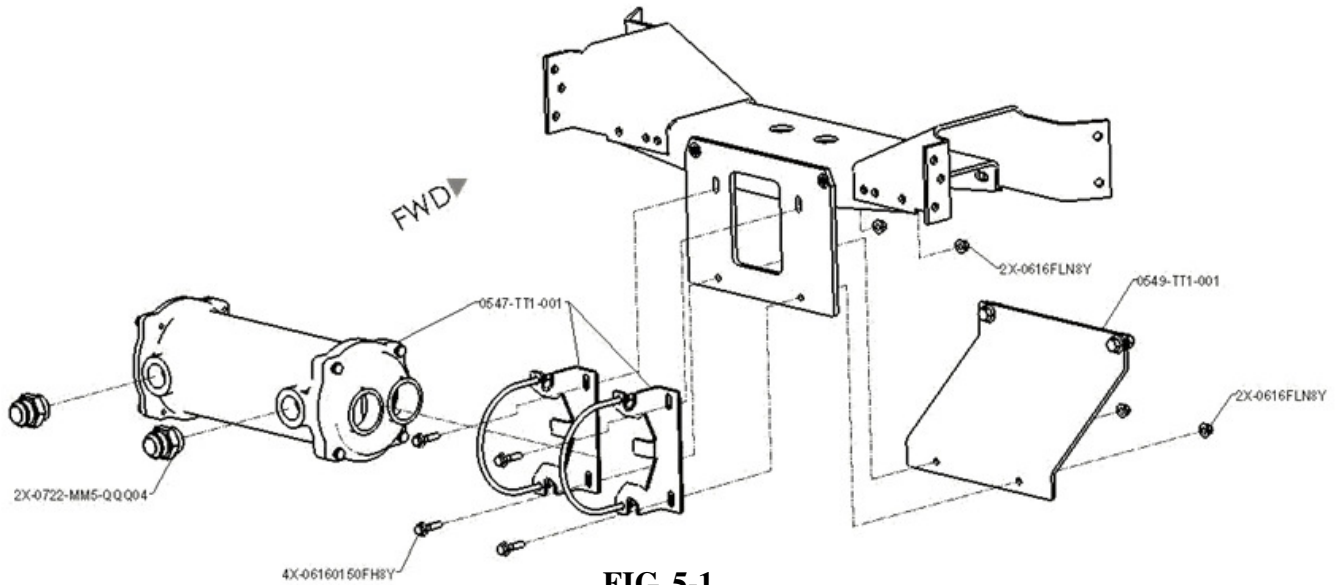

**FIG. 5-1**

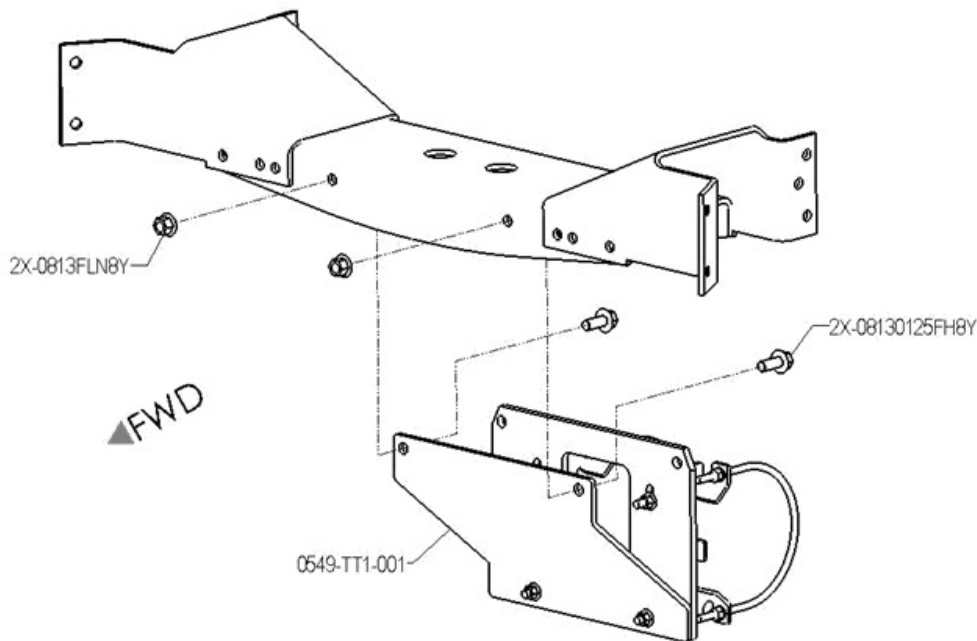
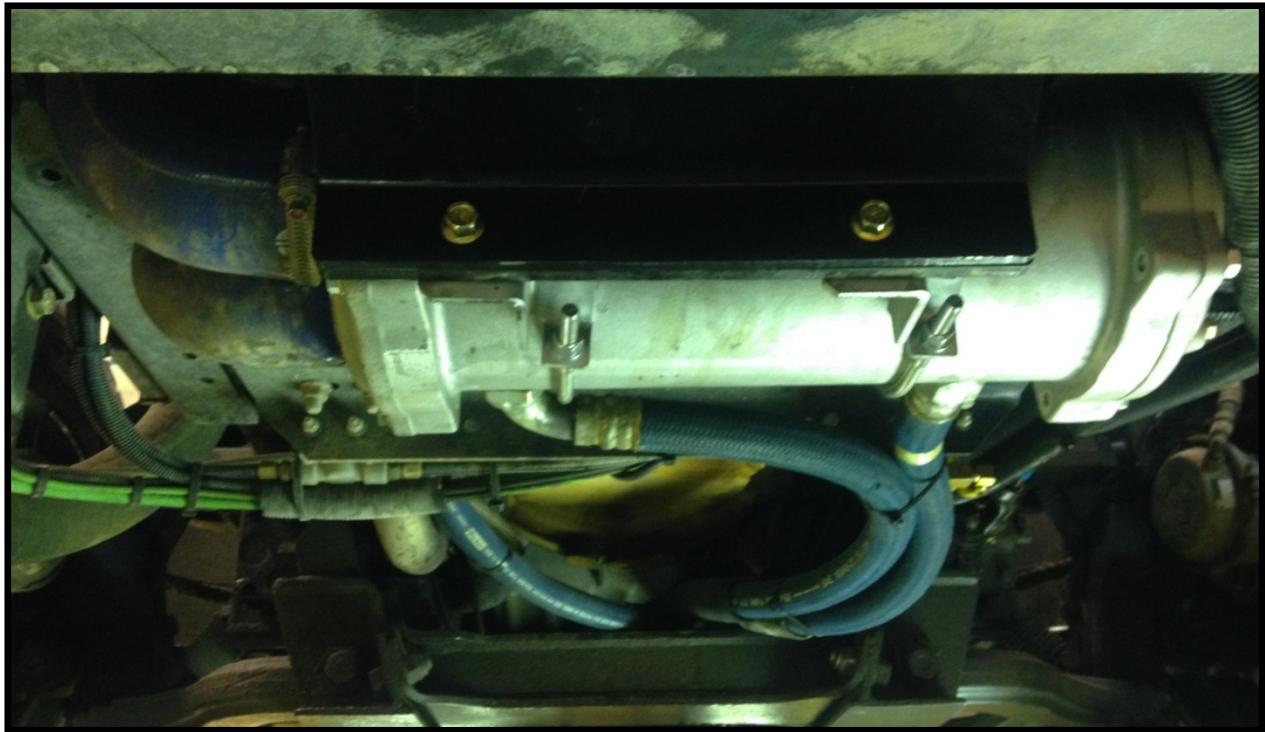

**FIG. 5-2**

Technical Service Bulletins are intended for use by Professional Technicians only. They are written to guide Professional Technicians in performing service to vehicles of product specific nature in conjunction with industry standards. Professional Technicians are appropriately trained on industry standards and have the tools and equipment to perform procedures safely and properly.



14. Position transmission oil cooler so the transmission lines and coolant hoses line up and tighten the hardware to final torque. U-bolts should be torqued to 10-11 lbs.-ft. 3/8" fasteners should be torqued to 27-34 lbs.-ft. on the nut side. 1/2" fasteners should be torqued to 67-82 lbs.-ft. on the nut side. Adjust as needed to ensure adequate clearance (~1/4") of cooler and fittings to any non-mounting component nearby. Additional clearance required to the engine (~3/4").
15. Install silicone elbows and torque clamps to 40-50 lbs.-in.
16. Install transmission cooler line fittings 0722-MM5-QQQ04 and torque to 87-108 lb-ft.
17. Install transmission cooler lines referring to previous installation as removed, and torque to 1 FFWR (Flats from Wrench Resistance) (ref 168 lbs.-in).
18. Use cable ties to secure hoses as needed to ensure they cannot rub or chafe on other components. Refer to FIG. 6-1.



**FIG. 6-1**

19. Install skid plate/recirculation shield if removed and torque hardware appropriately.
20. Insure coolant drains are closed and pump retained coolant back into radiator.

Technical Service Bulletins are intended for use by Professional Technicians only. They are written to guide Professional Technicians in performing service to vehicles of product specific nature in conjunction with industry standards. Professional Technicians are appropriately trained on industry standards and have the tools and equipment to perform procedures safely and properly.



# Spartan Motors Chassis, Inc.

SERVICE BULLETIN

RSB14-270-006A

NHTSA Id: 14V-623

Transport Canada Id: TC14-466

4/6/2015

21. Add approved transmission oil until it reaches the cold fill on the dipstick.
22. Start truck and allow it to heat to operating temp.
23. Follow Allison's instructions for checking proper fluid level.
24. Ensure there are no leaks.
25. Allow truck to cool and re-check engine coolant level and fill as required.

Technical Service Bulletins are intended for use by Professional Technicians only. They are written to guide Professional Technicians in performing service to vehicles of product specific nature in conjunction with industry standards. Professional Technicians are appropriately trained on industry standards and have the tools and equipment to perform procedures safely and properly.