

TECHNICAL INSTRUCTIONS

FOR

SAFETY RECALL E02

REAR LEAF SPRING REPLACEMENT

CERTAIN 2005 – 2011 MODEL YEAR TACOMA

PHASED REMEDY LAUNCH

- VINs will be opened for the remedy based on the vehicle's registered location. Always use TIS to confirm that the remedy is open prior to performing the repair. Vehicles opened for the remedy can have the repair performed at any authorized Toyota dealership regardless of geographical location.
- When each phase of VINs are opened for the E02 remedy phase, a small number of these vehicles that are also involved in campaign E0D or ESD and have had a frame replacement, which includes the replacement of the leaf springs will not require the E02 remedy and will be marked as 'Completed' in TIS.
- If a vehicle is in the interim phase and is exhibiting the Safety Recall condition (fractured leaf spring), dealers are requested to contact their regional representative. The case will be reviewed and further instructions will then be provided

| Phase | State Registration | Notification Type | TIS Designation | Anticipated Remedy Date |
|-------|----------------------------|-------------------|-----------------|-------------------------|
| 1 | MA, ME, NH, RI, VT | Remedy | E02 | Late January, 2016 |
| 2 | CT, NJ, NY | Remedy | E02 | Mid-February, 2016 |
| 3 | DE, MD, PA, VA, WV | Remedy | E02 | Early March, 2016 |
| 4 | IL, IN, MN, WI | Remedy | E02 | Late March, 2016 |
| 5 | KY, MI, OH, TN | Remedy | E02 | Late March, 2016 |
| 6 | AZ, CO, NM, NV, UT, WY | Remedy | E02 | Early April, 2016 |
| 7 | AK, ID, MT, OR, WA | Remedy | E02 | Early April, 2016 |
| 8 | MO, KS, IA, NE, ND, SD | Remedy | E02 | Mid-April, 2016 |
| 9 | Southern California | Remedy | E02 | Mid-April, 2016 |
| 10 | Northern California | Interim | E12 | Mid-April, 2016 |
| 11 | FL, GA, AL, NC, SC | Interim | E12 | Late April, 2016 |
| 12 | AR, LA, MS, OK, TX, HI, PR | Interim | E12 | Early May, 2016 |

The repair quality of covered vehicles is extremely important to Toyota. All dealership technicians performing this repair are required to successfully complete the most current version of the E-Learning course "Safety Recall and Service Campaign Essentials". To ensure that all vehicles have the repair performed correctly; technicians performing this repair are required to currently hold at least one of the following certification levels:

- Certified Technician (Chassis)
- Expert Technician (Chassis)
- Master Technician
- Master Diagnostic Technician

It is the dealership's responsibility to select technicians with the above certification level or greater to perform this repair. Carefully review your resources, the technician skill level, and ability before assigning technicians to this repair. It is important to consider technician days off and vacation schedules to ensure there are properly trained technicians available to perform this repair at all times.

I. OPERATION FLOW CHART

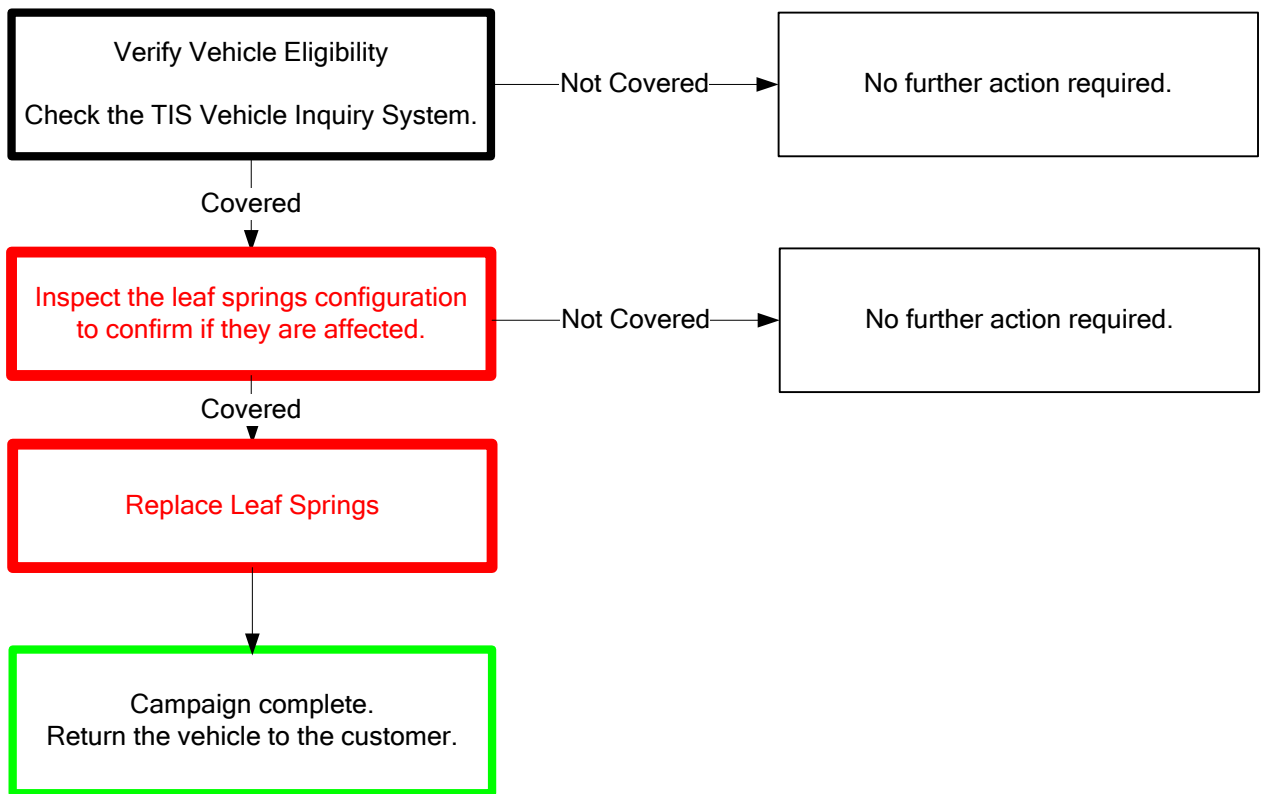

II. IDENTIFICATION OF AFFECTED VEHICLES

A. COVERED VIN RANGE

- Check the TIS Vehicle Inquiry System to confirm the VIN is involved in this Safety Recall, and that the campaign has not already been completed prior to dealer shipment or by another dealer.
- TMS warranty will not reimburse dealers for repairs conducted on vehicles that are not affected or were completed by another dealer.

III. PREPARATION

A. PARTS

Parts Ordering Process - Non SET and GST Parts Ordering Process

Due to limited availability, the parts have been placed on either Manual Allocation Control (MAC) or Dealer Ordering Solutions (DOS). As the parts inventory improves, the ordering process may change. Please check the Toyota Special Activities MAC/DOS report on Dealer Daily for the most up-to-date parts ordering information.

As always, if a customer experiences the condition described, dealers should conduct appropriate diagnosis and order the applicable parts.

All Safety Recall, Service Campaign (SSC/LSC) and Customer Support Program (CSP) parts are eligible for the Monthly Parts Return Program. Please refer to PANT Bulletin 2011-087 for campaign parts that are currently returnable under the Monthly Parts Return Program and additional details.

Leaf Spring Kit Shipping and Receiving of Parts:

Note that the large majority of leaf spring kits will not be stocked at local PDCs; they will be shipped directly from a specific NAPO facility located in Texas. Lead time for these kits is expected to be 5-7 business days depending on dealer location. Toyota is currently working to reduce this lead time to 1-3 days.

The leaf spring kits for this campaign are large and heavy, please take note of the following weight and dimension specs when preparing your parts department for receiving these campaign parts.



Individual Leaf Spring Kits:

- Weight 142 lbs.
- 61" x 16" x 9.5"

Bulk Leaf Spring Kit Packaging:

- Banded in Sets of 6
- Weight 852 lbs.
- Dimension 61" x 32" x 28.5"

Both bulk shipment and individual kits will be capable of being moved by pallet jacks and forklifts.

HARDWARE KIT:

| Part Number | Part Description | Quantity | | | | | | | | | | | | | | | | | | | | | | |
|---|--------------------------|----------|------------------|-----|-------------------------|---|--------------------|---|------|---|-----|----|--------|----|-----|---|--------|---|------|---|--------|---|------------------|---|
| 04005-34104 | Leaf Spring Hardware Kit | 1 | | | | | | | | | | | | | | | | | | | | | | |
| The kit listed above includes the following parts: | | | | | | | | | | | | | | | | | | | | | | | | |
| <table border="1"><thead><tr><th>Part Description</th><th>Qty</th></tr></thead><tbody><tr><td>Rear Spring Bumper No.1</td><td>2</td></tr><tr><td>Spring U-bolt Seat</td><td>2</td></tr><tr><td>Bolt</td><td>4</td></tr><tr><td>Nut</td><td>14</td></tr><tr><td>Washer</td><td>14</td></tr><tr><td>Nut</td><td>2</td></tr><tr><td>Washer</td><td>2</td></tr><tr><td>Bolt</td><td>2</td></tr><tr><td>U-Bolt</td><td>4</td></tr><tr><td>Shackle Bushings</td><td>4</td></tr></tbody></table> | | | Part Description | Qty | Rear Spring Bumper No.1 | 2 | Spring U-bolt Seat | 2 | Bolt | 4 | Nut | 14 | Washer | 14 | Nut | 2 | Washer | 2 | Bolt | 2 | U-Bolt | 4 | Shackle Bushings | 4 |
| Part Description | Qty | | | | | | | | | | | | | | | | | | | | | | | |
| Rear Spring Bumper No.1 | 2 | | | | | | | | | | | | | | | | | | | | | | | |
| Spring U-bolt Seat | 2 | | | | | | | | | | | | | | | | | | | | | | | |
| Bolt | 4 | | | | | | | | | | | | | | | | | | | | | | | |
| Nut | 14 | | | | | | | | | | | | | | | | | | | | | | | |
| Washer | 14 | | | | | | | | | | | | | | | | | | | | | | | |
| Nut | 2 | | | | | | | | | | | | | | | | | | | | | | | |
| Washer | 2 | | | | | | | | | | | | | | | | | | | | | | | |
| Bolt | 2 | | | | | | | | | | | | | | | | | | | | | | | |
| U-Bolt | 4 | | | | | | | | | | | | | | | | | | | | | | | |
| Shackle Bushings | 4 | | | | | | | | | | | | | | | | | | | | | | | |

Parts Continued...

LEAF SPRING KITS:

Only one kit is required per vehicle. Ensure you order the correct set based on the vehicle configuration.

| Part Number | Part Description | Quantity |
|---|--------------------------------------|------------|
| 04005-34204 | Leaf Spring Kit (Regular Cab Models) | 1 |
| The kit listed above includes the following parts: | | |
| Part Description | | Qty |
| Leaf Spring, RH | | 1 |
| Leaf Spring LH | | 1 |

| Part Number | Part Description | Quantity |
|---|---|------------|
| 04005-34304 | Leaf Spring Kit (Access/DBL Cab Models) | 1 |
| The kit listed above includes the following parts: | | |
| Part Description | | Qty |
| Leaf Spring, RH | | 1 |
| Leaf Spring LH | | 1 |

The following leaf spring kit should only be installed on vehicles who previously had T-SB-0359-10, Rear Spring Harsh Ride, performed on the vehicle. This kit will only be needed in rare cases, the inspection procedure in the TI will identify if this kit is needed.

| Part Number | Part Description | Quantity |
|---|---|------------|
| 04005-34404 | Leaf Spring Kit (Access/DBL Cab Models with Mexico and Canada Spec Springs) | 1 |
| The kit listed above includes the following parts: | | |
| Part Description | | Qty |
| Leaf Spring, RH | | 1 |
| Leaf Spring LH | | 1 |

ANCILLARY SHACKLE HOUSING KIT:

The following kit should only be ordered if rear shackle bushing replacement is not feasible. It is anticipated that very few vehicles will require these parts.

| Part Number | Part Description | Quantity |
|-------------|--|----------|
| 04005-65104 | Rear Shackle Housing Kit (contains 2 shackle housings) | 1 |

B. TOOLS & EQUIPMENT

- Standard hand tools
- Torque Wrench
- Press
- Air Hammer
- Panel Cutting Bit

SPECIAL SERVICE TOOLS – These are essential special service tools that the dealership should have.

| SST Number | SST Name |
|------------------|--------------------------|
| 09710-18020-01-2 | Rear Suspension Bush Kit |
| 09951-00190 | 19mm Replacer |
| 09950-70010 | Handle Set |

C. MATERIALS

- Work Gloves
- Protective Glasses
- Tape

IV. BACKGROUND

The subject vehicles' rear suspension system contains leaf springs that are constructed of either three or four leaves. There is a possibility that a leaf could fracture due to stress and corrosion. If this occurs and the vehicle continues to be operated, the broken leaf could move out of position and contact surrounding components, including the fuel tank. If the broken leaf contacts the fuel tank repeatedly, it could puncture the tank and cause a fuel leak. In the presence of an ignition source, this could result in a fire.

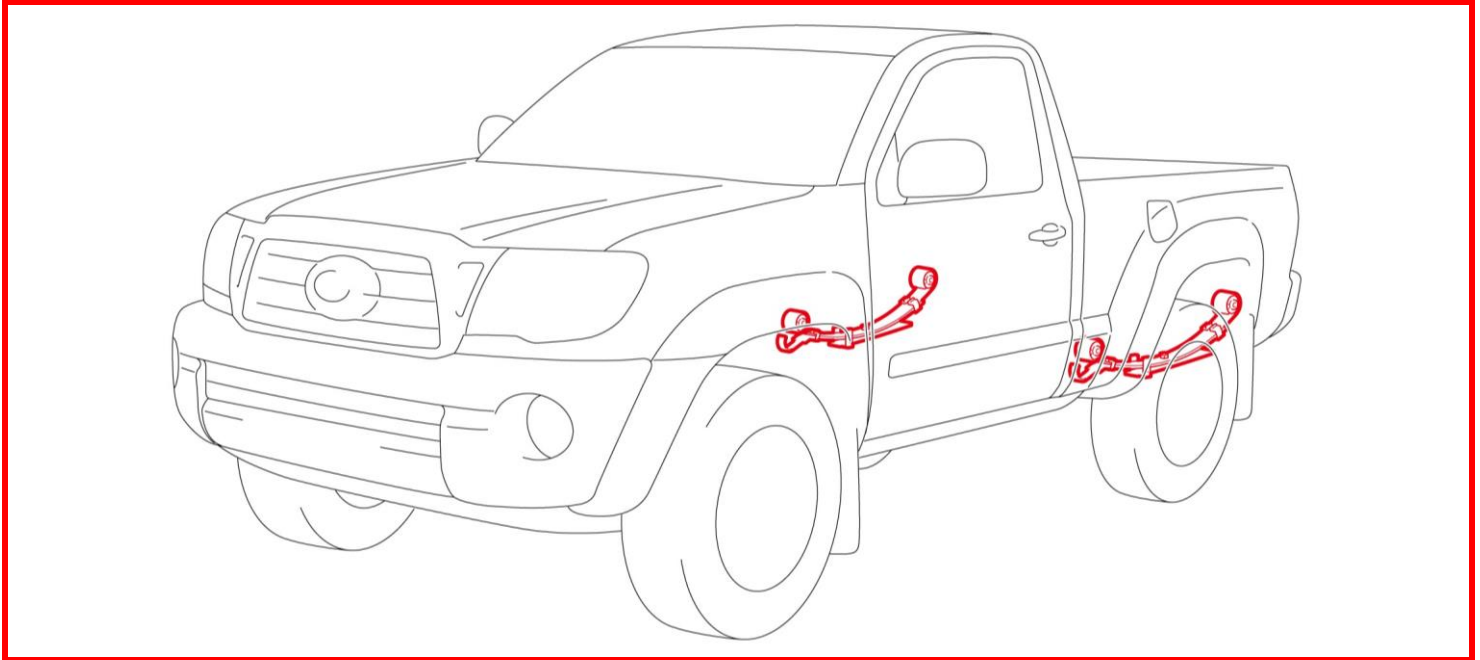

V. LEAF SPRING INSPECTION PROCEDURE

A. INSPECT THE LEAF SPRING CONFIGURATION

1. 3 LEAF SPRING ASSEMBLY CONFIGURATION INSPECTION

a) Inspect the leaf spring assembly and confirm the number of leaf retention clips.

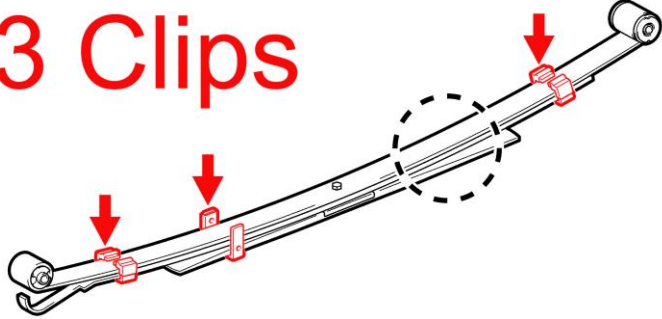
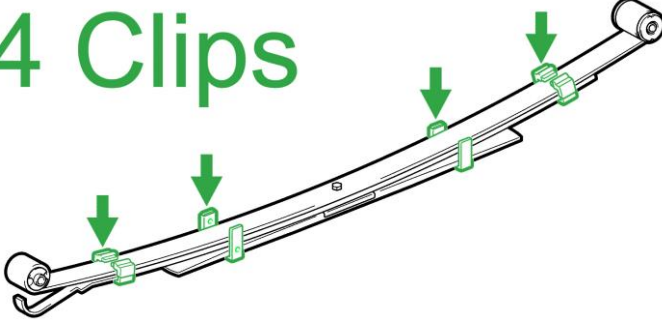
| Result | Quantity of Clips | Action Required |
|-----------|---|--|
| NG | <p>3 Clips</p>  | <p>Rear leaf spring has to be replaced with a NEW one</p> |
| OK | <p>4 Clips</p>  | <p>Rear leaf spring does NOT have to be replaced</p> |

2. 4 LEAF SPRING ASSEMBLY CONFIGURATION INSPECTION

a) Inspect the leaf spring assembly and confirm the number of leaf retention clips.

If the vehicle is equipped with the NG 4 leaf stack identified below the vehicle had the harsh ride TSB performed or was originally equipped with Mexico/Canada spec springs. These vehicles will require leaf spring kit 04005-34404.

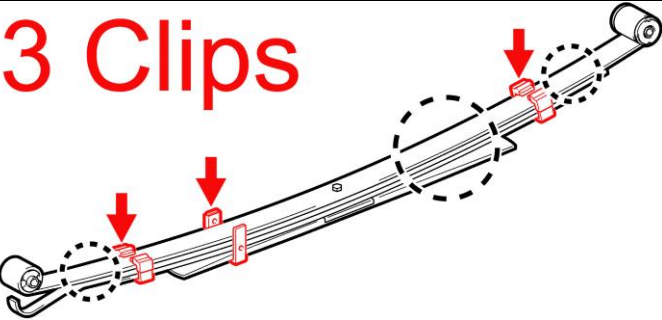
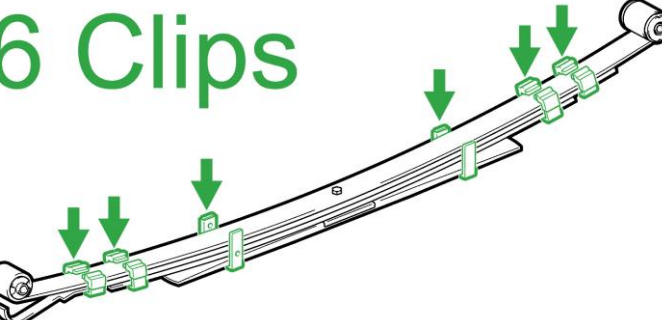
| Result | Quantity of Clips | Action Required |
|-----------|--|--|
| NG | <p>3 Clips</p>  | <p>Rear leaf spring has to be replaced with a NEW one</p> |
| OK | <p>6 Clips</p>  | <p>Rear leaf spring does NOT have to be replaced</p> |

B. INSPECT THE LEAF SPRING CRACKS AND ANCILLARY COMPONENT DAMAGE

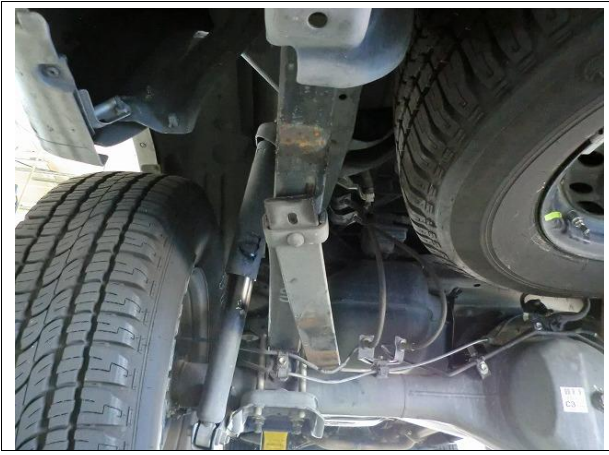

1. CONFIRM THE INTEGRITY OF THE LEAF SPRINGS

- a) Inspect the leaf springs for damage.

Damage or Broken: Continue with Ancillary Part Inspection

No Damage: Proceed to Section VI - Leaf Spring Replacement Procedure

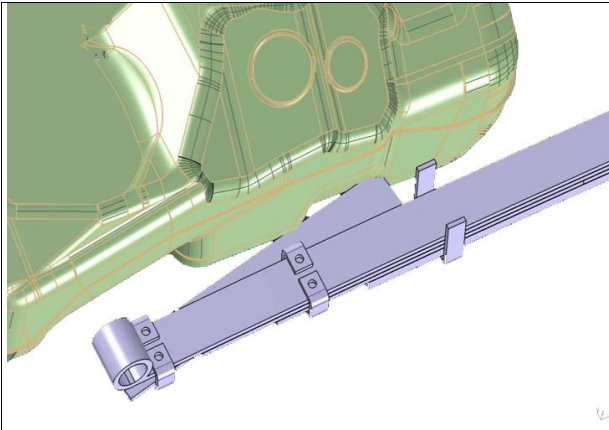

2. INSPECT THE FUEL TANK FOR DAMAGE



3. INSPECT THE SHOCK ABSORBER FOR DAMAGE



4. INSPECT THE BRAKELINE AND ABS WIREHARNES FOR DAMAGE

5. IF COMPONENTS HAVE DAMAGE REPLACE AS NEEDED

VI. LEAF SPRING REPLACEMENT PROCEDURE

A. COMPONENTS

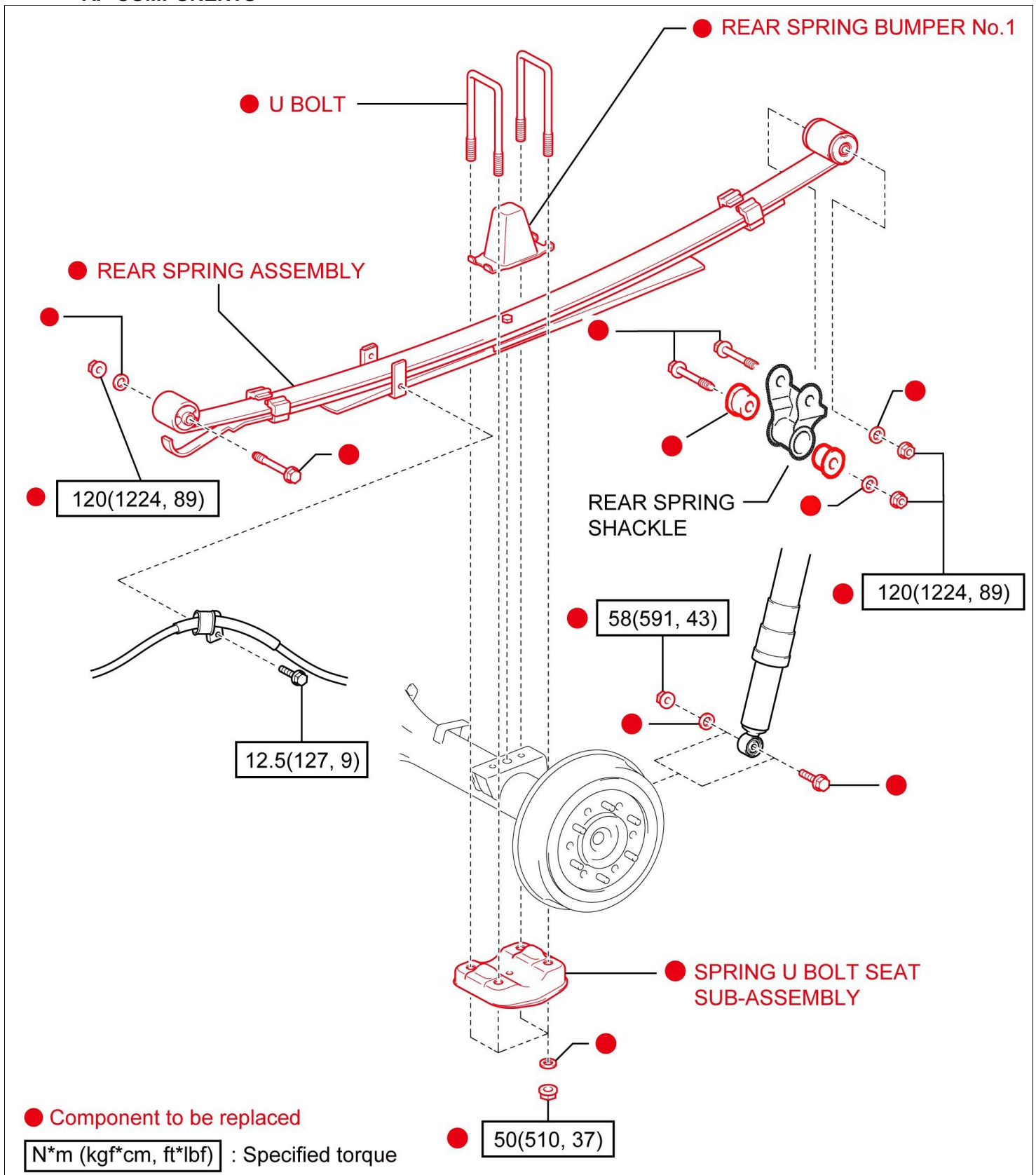

B. LEAF SPRING REMOVAL PROCEDURE

1. SUPPORT THE REAR AXLE USING A SCREW JACK

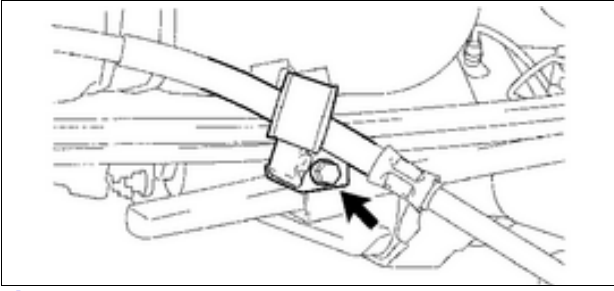

2. REMOVE THE PARKING BRAKE CABLE BRACKET



This bolt will be reused and is a unique length, ensure you place it in a safe place and reinstall it in the correct location.

3. REMOVE THE LOWER SHOCK BOLT AND NUT

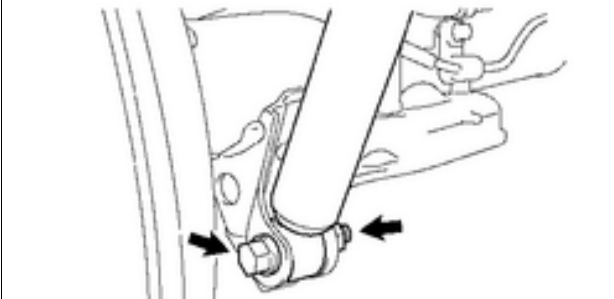

4. REMOVE REAR SPRING U-BOLTS

- Remove the 4 nuts and 4 washers.
- Remove the two U-bolts.
- Remove the rear bump stop.
- Slowly lower the rear axle until the leaf spring guide pin disengages from the rear axle assembly.



Use caution when lowering the rear axle to ensure you do not place tension on the brake hoses.

5. REMOVE REAR LEAF SPRING

- Remove the nut, washer and bolt securing the front of the leaf spring to the frame.
- Remove the nut, washer and bolt securing the shackle to the frame.
- Remove the rear leaf spring.

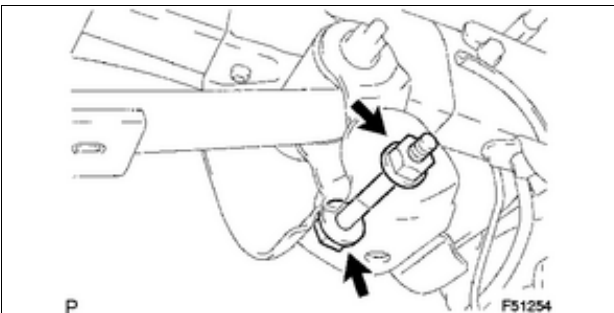
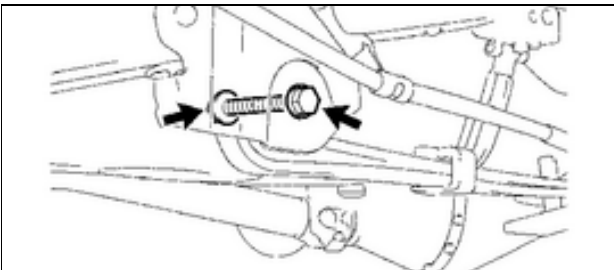
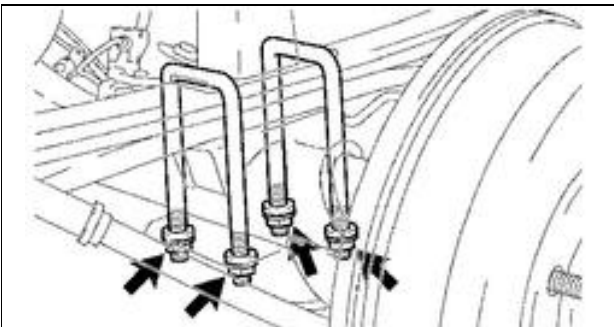

6. REMOVE THE SHACKLE FROM THE LEAF SPRING ASSEMBLY.

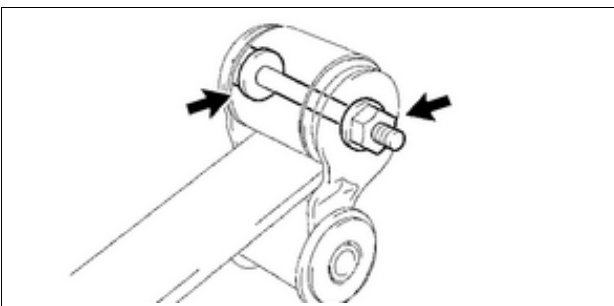

C. SHACKLE ASSEMBLY BUSHING REPLACEMENT PROCEDURE

[Bushing Replacement Supplemental Video](#)

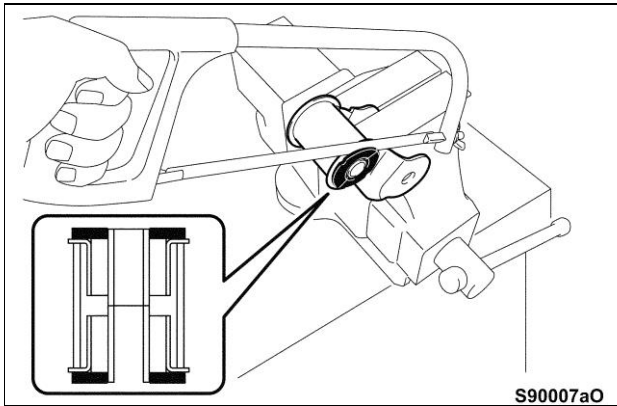

1. CUT THE RUBBER BUSHING FLANGES OFF

- a) Place the shackle in vise as shown.

Note: Place a shop rag in-between the jaws of the vise and the shackle housing to prevent damage to the E-coat.

- b) Using a hack saw cut the bushing flange off of both sides of the shackle.

Note: Do not cut through the inner bushing tube to ensure you have a flat surface to press against.

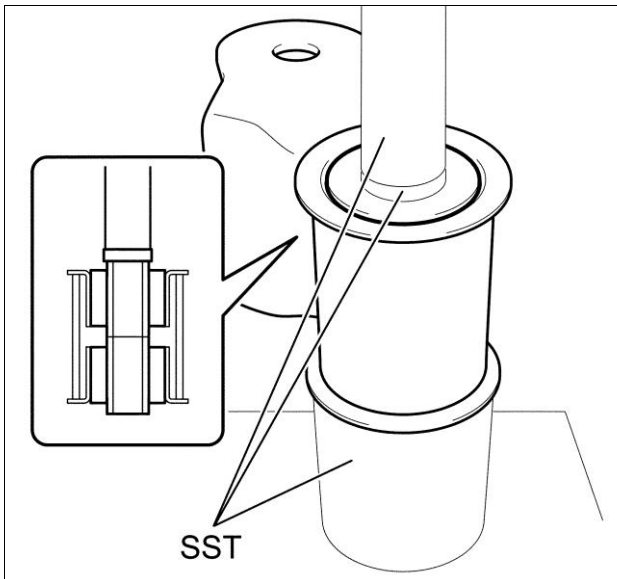

2. PRESS OUT INNER BUSHING TUBE AND BUSHING RUBBER

- a) Using a press and the following SSTs press the inner bushing tube and rubber out of the shackle housing.

Special Service Tools:

- 09710-18020-01-2: Rear Suspension Bush Kit
- 09951-00190 : 19mm Replacer
- 09950-70010: Handle Set



- **ALWAYS** wear eye protection
- Use caution when pressing out the bushing rubber and inner tube

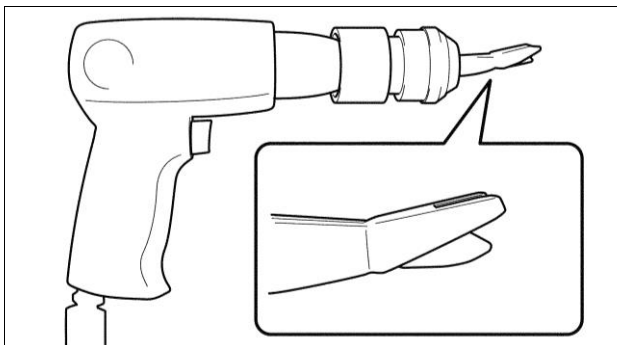

3. REMOVE THE OUTER BUSHING TUBES

- a) Remove the outer bushing tube using an air hammer with a panel cutting bit.

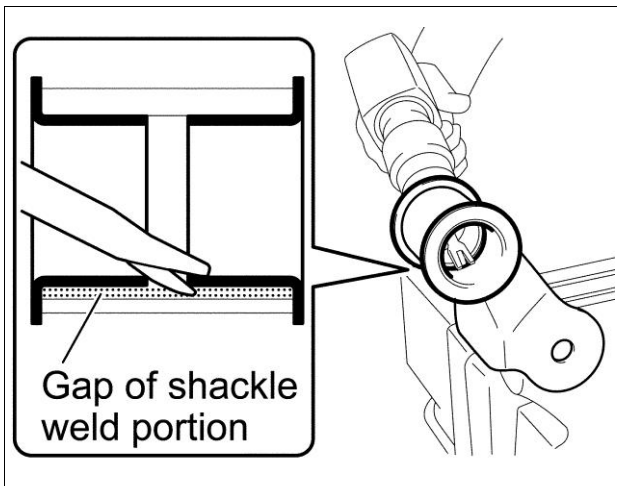

- b) Place the shackle in the vise at the angle shown so the weld of the shackle is located at the 6 o'clock position (as shown).
- c) Place the panel cutting bit on the inner edge of the bushing tube at the 6 o'clock position and drive out the tube.

Note: By placing the bit in this position the backside tooth of the bit will ride in the gap between the welded pieces of metal ensuring that the shackle housing does not get damaged (shown in upper right hand picture).



- Always wear eye protection when performing this step.

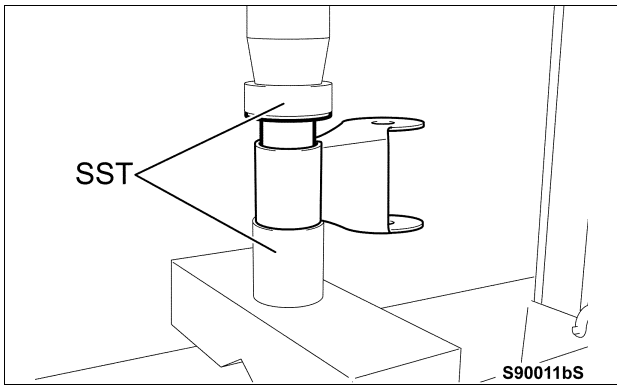

4. INSTALL THE **NEW** BUSHINGS INTO THE SHACKLE

- a) Using a press and the following SSTs press the **NEW** bushings into the shackle housing.

Special Service Tools:

- 09710-18020-01-2: Rear Suspension Bush Kit
- 09710-07062 : 19mm Replacer



- **ALWAYS** wear eye protection
- Use caution when pressing out the bushing rubber and inner tube

D. LEAF SPRING INSTALLATION PROCEDURE

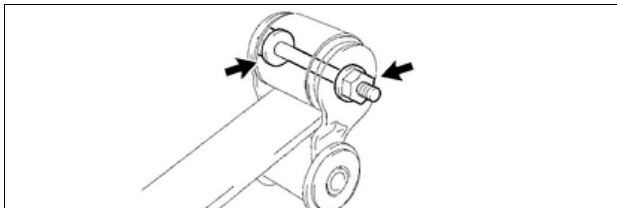

1. INSTALL THE REAR SHACKLE ASSEMBLY ONTO THE **NEW** LEAF SPRING

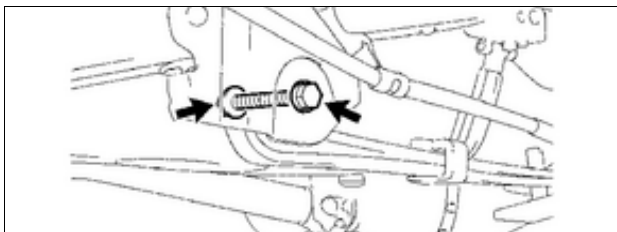

2. INSTALL THE **NEW** LEAF SPRING

- a) Align the holes and install the **NEW** hardware (bolt , washer and nut).

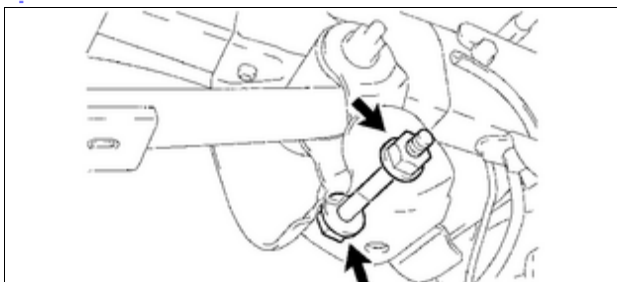

- b) Align the holes and install the **NEW** hardware (bolt , washer and nut).

Note: Ensure the bolt and washer are installed in the correct orientation.

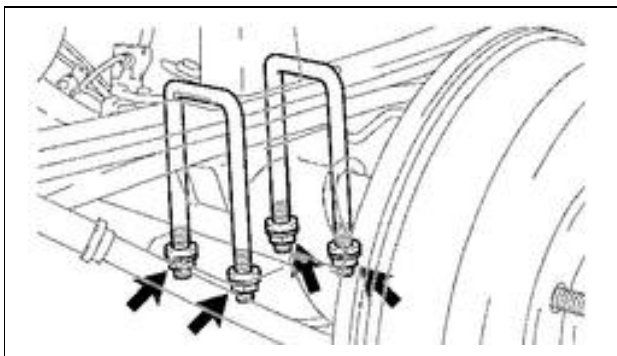

- c) While raising the rear axle assembly align the leaf spring pin with the hole in the rear axle assembly.
- d) Install the leaf spring to the rear axle with the **NEW** hardware:

- Bump Stop (Qty.1)
- U-Bolt Seat Assembly (Qty. 1)
- U-bolts (Qty. 2)
- Washers (Qty. 4)
- Nuts (Qty. 4)

- e) Evenly tighten the nuts on the U-bolts and torque to spec.

Torque Spec: 37ft lbs. (510kgf, 50Nm)

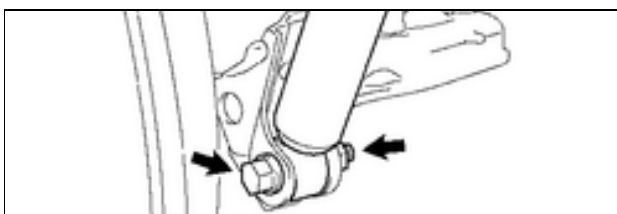

3. INSTALL THE SHOCK ABSORBER

- a) Install the lower shock absorber using the **NEW** hardware (bolt, washer and nut).

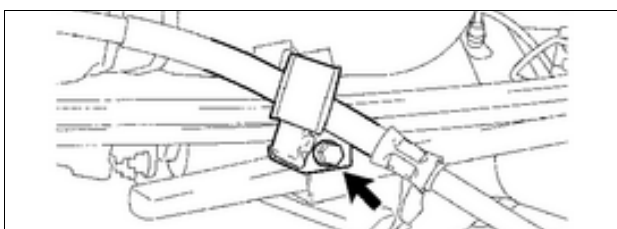

4. REINSTALL THE PARKING BRAKE CABLE BRACKET

Torque Spec: 9ft lbs. (127kgf, 12.5Nm)

5. REPEAT LEAF SPRING REPLACEMENT PROCEDURE FOR THE OTHER SIDE

6. STABILIZE THE SUSPENSION

a) Lower the vehicle and jounce the suspension up and down multiple times to stabilize the suspension.

7. FULLY TIGHTEN REAR SUSPENSION

Components:

- Leaf Spring to Rear Shackle
- Leaf Spring to Frame
- Rear Shackle to Frame

Torque Spec: 89ft lbs. (1224kgf, 120Nm)

Components:

- Rear Shock Absorber to Rear Axle

Torque Spec: 43ft lbs. (591kgf, 58Nm)

8. PERFORM VEHICLE ALIGNMENT

9. TEST DRIVE THE VEHICLE

◀ VERIFY REPAIR QUALITY ▶

- Confirm that the leaf springs were inspected properly
- Confirm that all surrounding components were inspected for damage
- Confirm that the correct leaf spring kit was installed
- Confirm that the rear suspension bolts are torqued properly

If you have any questions regarding this **Safety Recall**, please contact your regional representative.

VII. APPENDIX

A. CAMPAIGN PARTS DISPOSAL

Make sure all campaign parts (original parts) removed from the vehicle are disposed of in a manner in which they will not be reused, **unless requested for parts recovery return.**

B. CAMPAIGN DESIGNATION DECODER

