

TECHNICAL INSTRUCTIONS

FOR

SAFETY RECALL CAMPAIGN E11

CERTAIN 2014 MODEL YEAR AVALON, CAMRY, HIGHLANDER & SIENNA 2GR ENGINE FUEL DELIVERY PIPE SUB-ASSEMBLY INSPECTION

All dealership associates involved in the campaign process are required to successfully complete E-Learning course SC13A. To ensure that all vehicles have the repair performed correctly; technicians performing this recall repair are required to currently hold at least one of the following certifications levels:

- Toyota Certified (any classification)
- Toyota Expert (any classification)
- Master
- Master Diagnostic Technicians

I. OPERATION FLOW CHART

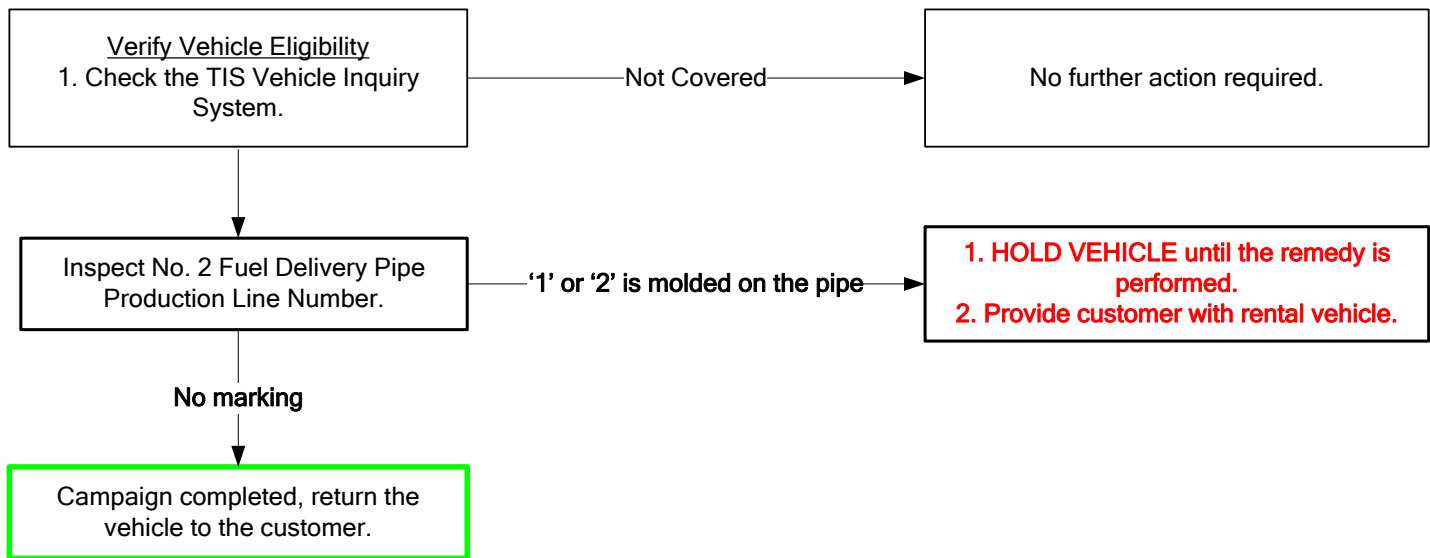

II. IDENTIFICATION OF AFFECTED VEHICLES

NOTE:

- Check the TIS Vehicle Inquiry System to confirm the VIN is involved in this SSC and that the campaign has not already been completed prior to dealer shipment or by another dealer.
- **TMS warranty will not reimburse dealers for repairs conducted on vehicles that are not affected or were completed by another dealer.**

III. PREPARATION

A. PARTS

No parts are needed to perform the inspection

B. TOOLS & EQUIPMENT

- Flash light
- Small Inspection Mirror
- Borescope (optional)

IV. BACKGROUND

In the subject vehicles, the Bank 1 (cowl side) fuel delivery pipe end cap could have been insufficiently welded during the manufacturing process. This condition can lead to a fuel leak in the engine compartment. Fuel leakage in the presence of an ignition source, could increase the risk of a vehicle fire.

V. COMPONENTS

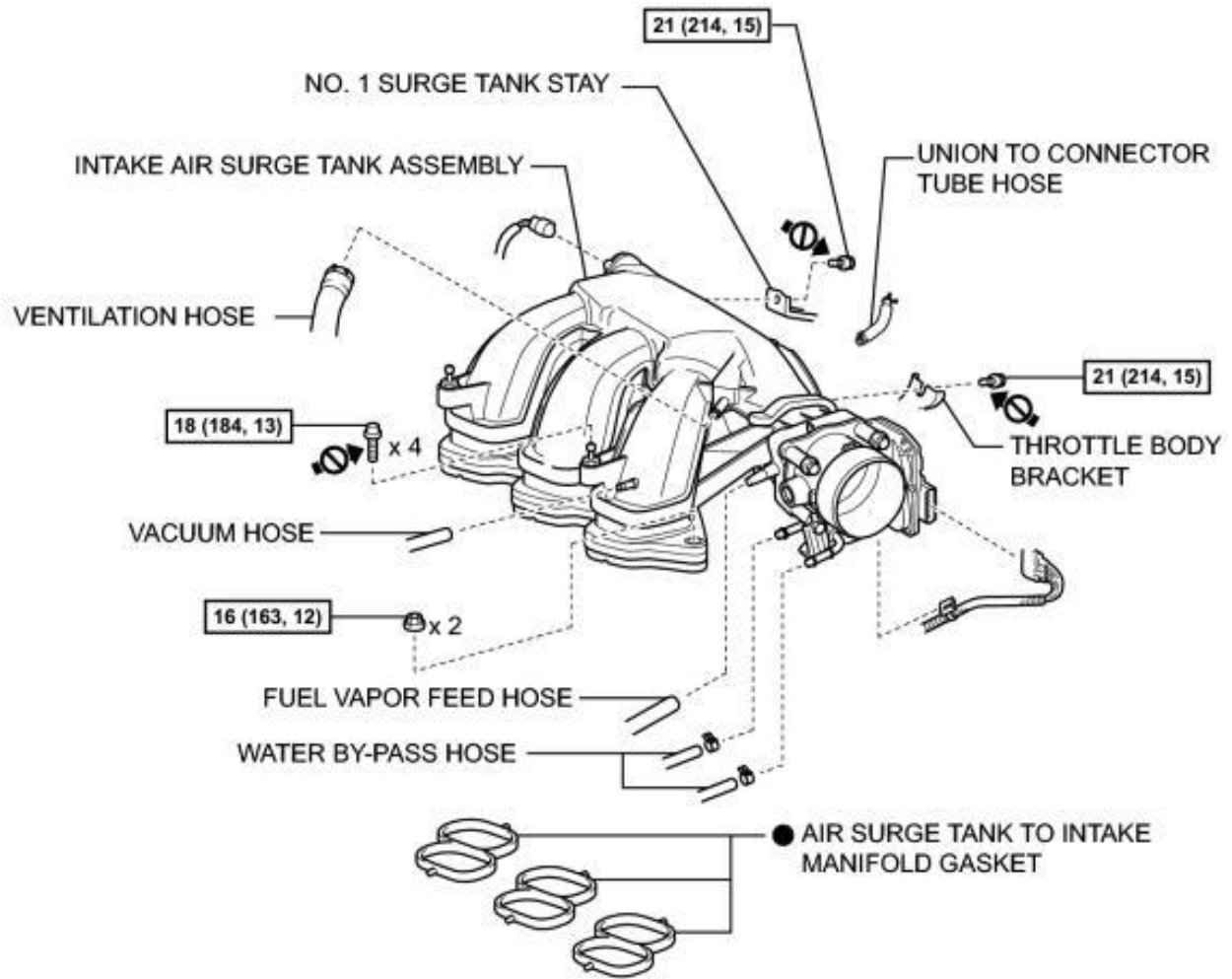

N*m (kgf*cm, ft.*lbf): Specified torque

● Non-reusable part

⚡ Do not apply lubricants (to the threaded parts)

c

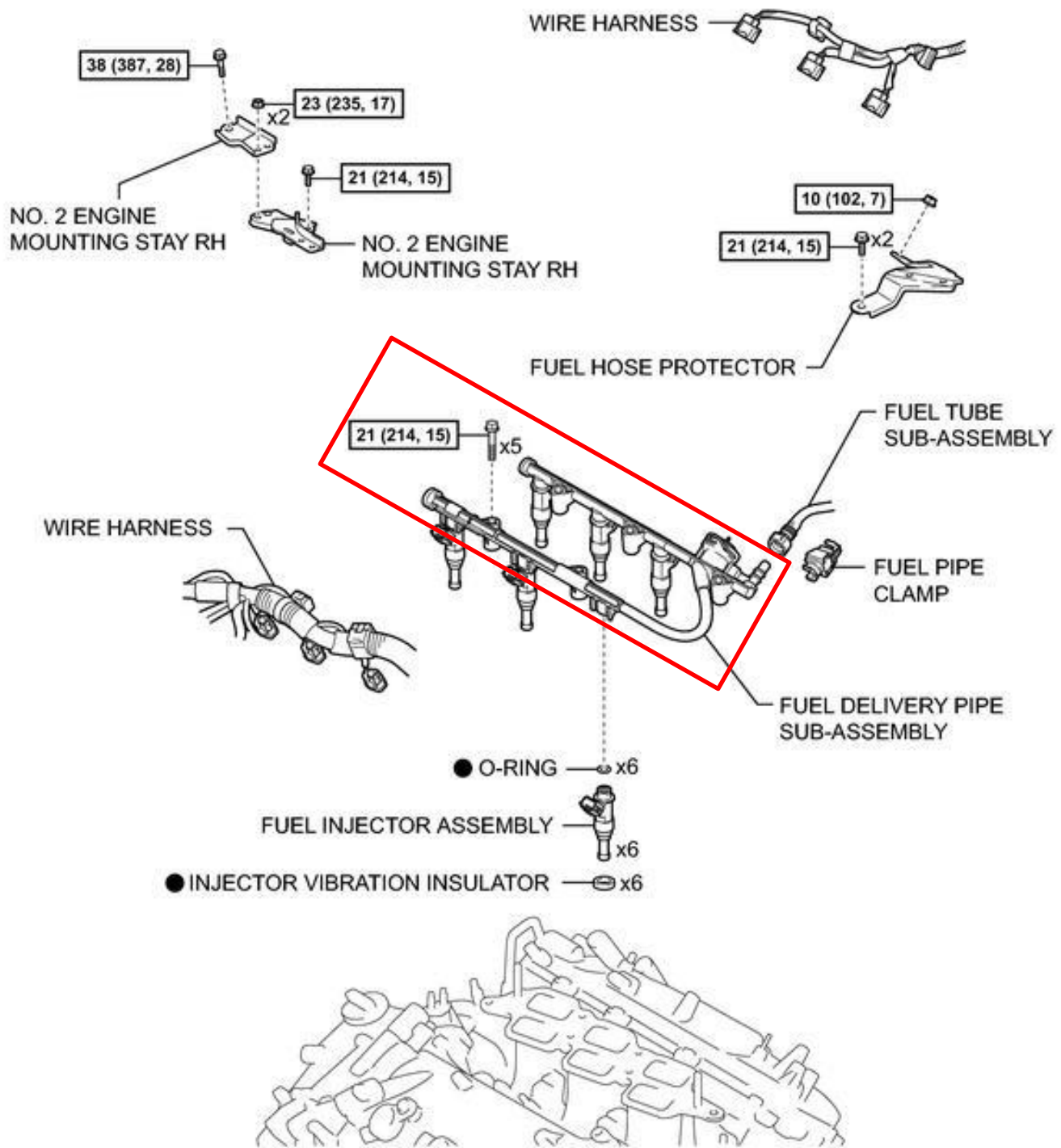

N*m (kgf*cm, ft.*lbf): Specified torque

● Non-reusable part

VI. WORK PROCEDURE

1. INSPECT FUEL DELIVERY PIPE

2. REMOVE THE V-BANK COVER SUB ASSEMBLY

Avalon, Camry and Highlander

- a) Hold the rear of the V-bank cover sub-assembly and raise it to disengage the 2 retainers on the front side.
- b) Raise the V-bank cover sub-assembly to disengage the retainer on the rear side and remove the V-bank cover sub-assembly.

Sienna

- a) Hold the front of the V-bank cover sub-assembly and raise it to disengage the 2 retainers on the front of the V-bank cover sub-assembly.
- b) Continue to raise the V-bank cover sub-assembly to disengage the 2 retainers on the rear of the V-bank cover sub-assembly and remove the V-bank cover sub-assembly.

NOTE: Attempting to disengage both front and rear retainers at the same time may cause the V-bank cover sub-assembly to break.

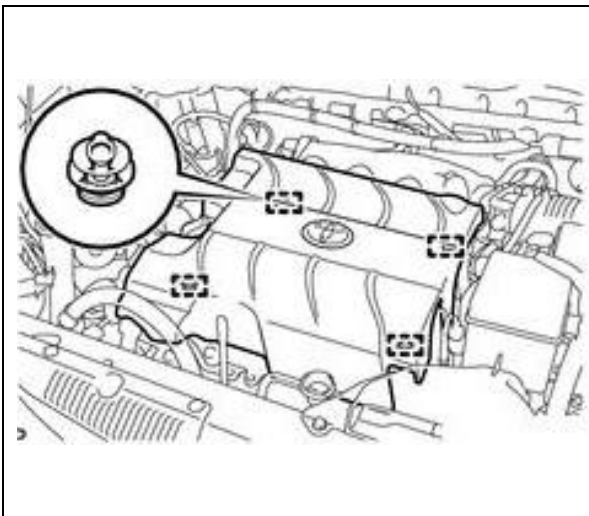
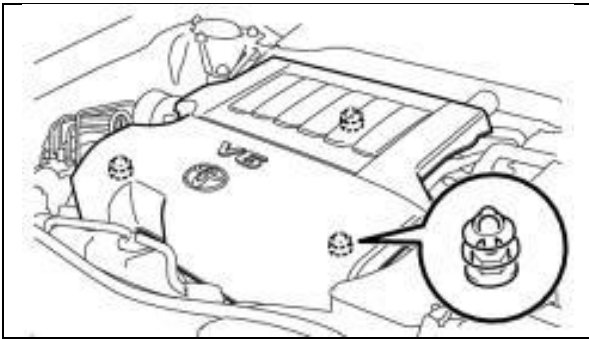

3. INSPECT THE No. 2 FUEL DELIVERY PIPE PRODUCTION LINE NUMBER

a) Using a mirror (or borescope) inspect the No. 2 fuel delivery pipe production line number.

NOTE: The production line number is located next to the injector at the front of the cylinder head.



- It is very important to look at this area very carefully at multiple angles with good lighting.
- The mirror needs to fit directly under the fuel pipe.

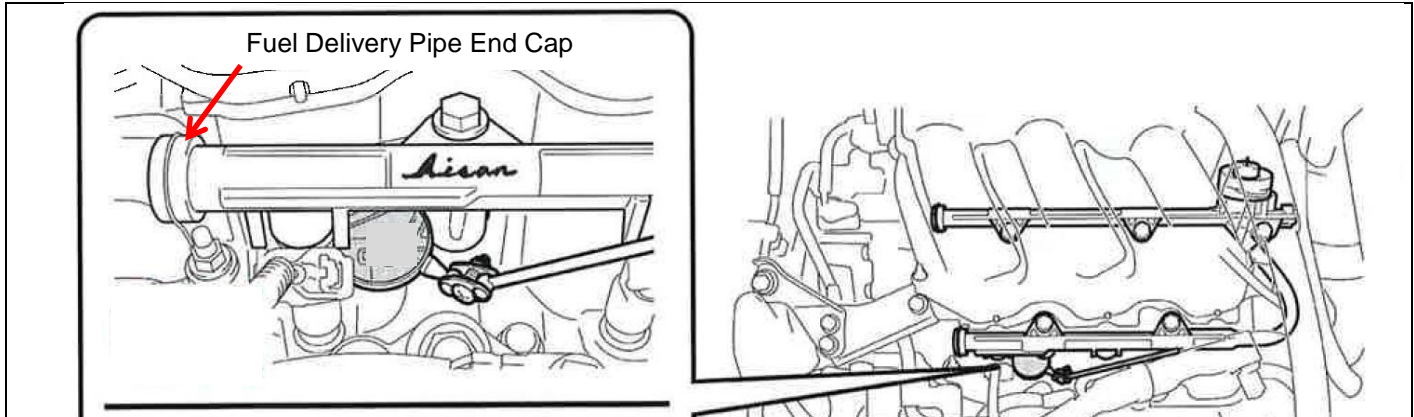

RESULTS

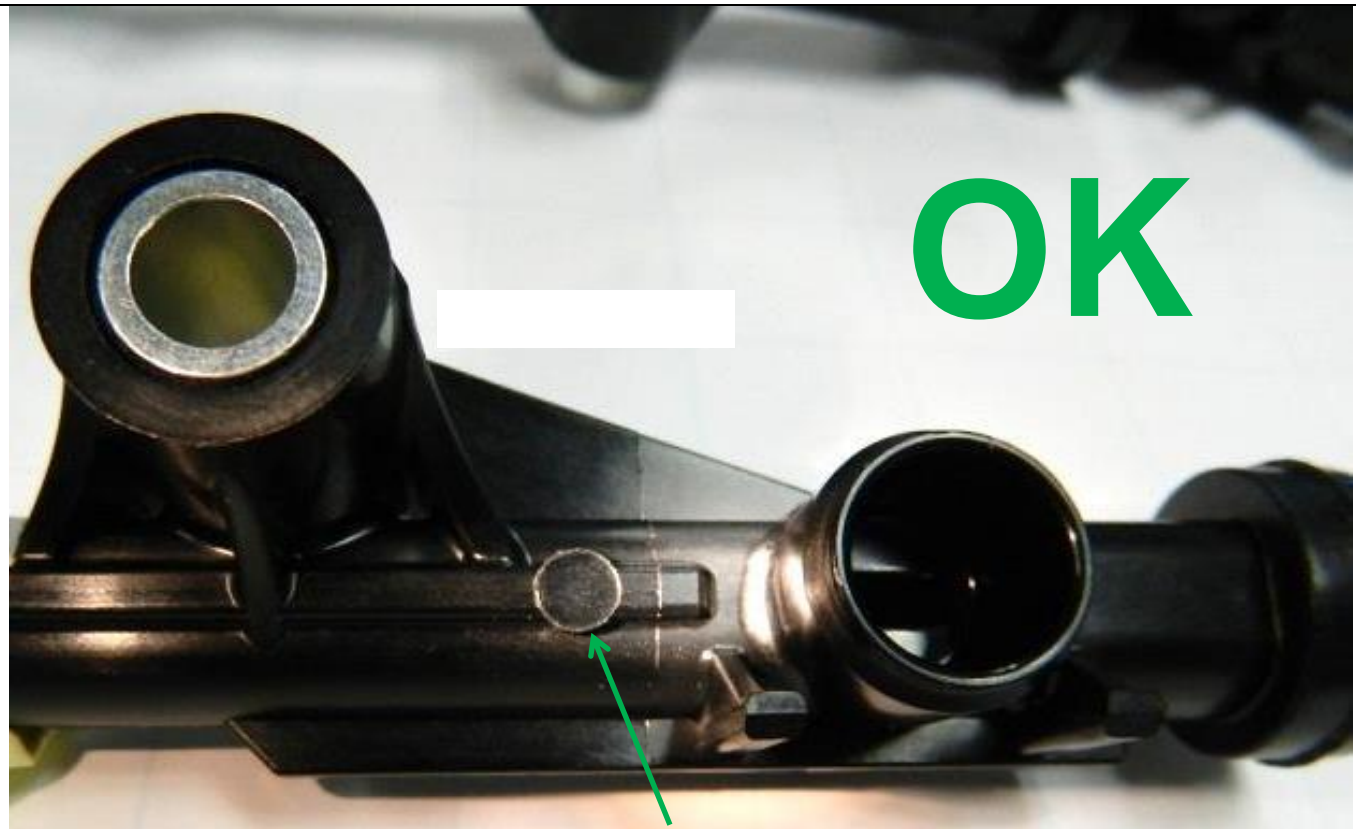

Blank

If there is no number on the fuel delivery pipe **Proceed to Step 4.**

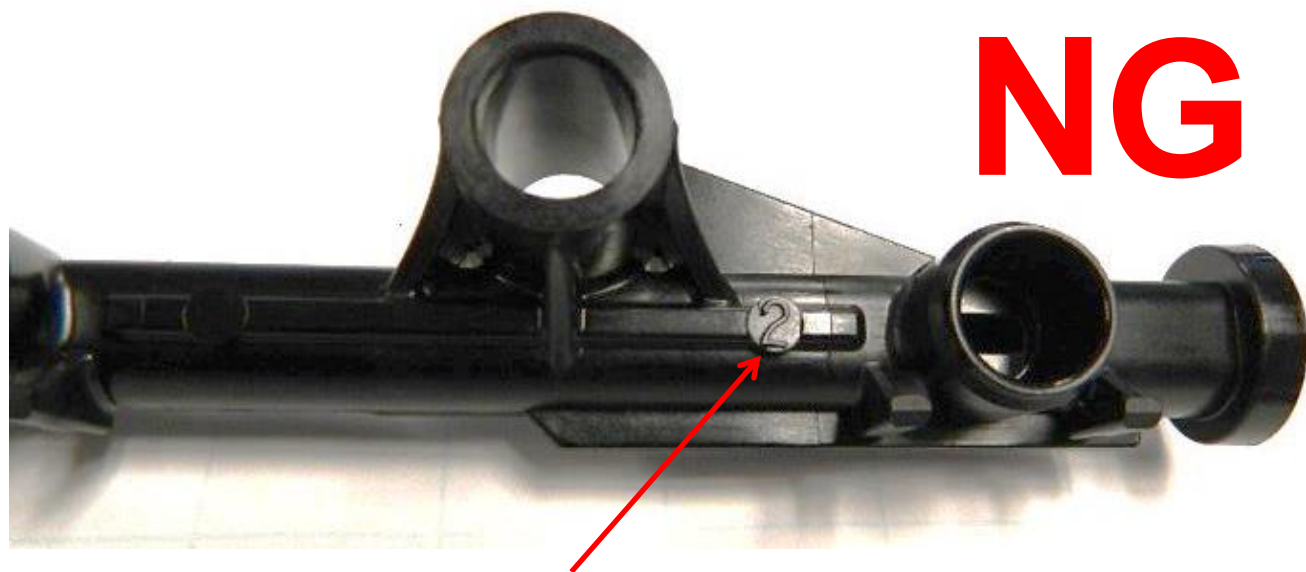

If the fuel delivery pipe has a **1** or **2** molded on to the pipe **HOLD THE VEHICLE** and wait to perform the repair. Provide customer with rental vehicle. . Refer to the dealer letter for additional information.

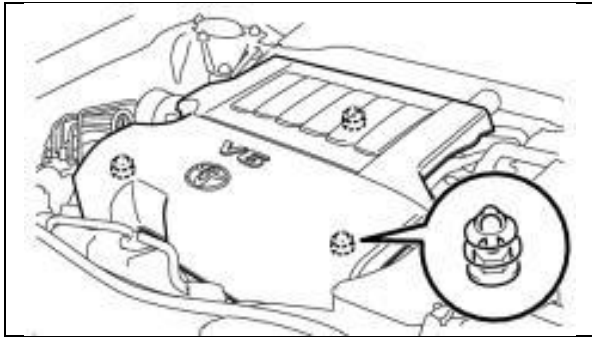

4. REINSTALL THE V-BANK COVER SUB ASSEMBLY

Avalon, Camry and Highlander

- a) Fit the 3 retainers and install the V-bank cover sub-assembly.
- b) Campaign complete.

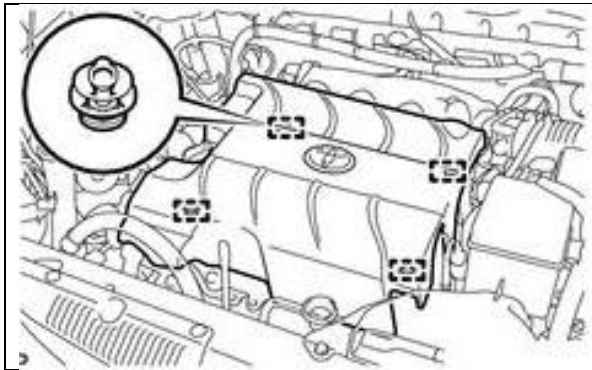

Sienna

- a) Fit the 4 retainers and reinstall the V-bank cover sub-assembly.
- b) Campaign complete.

◀ VERIFY REPAIR QUALITY ▶

If you have any questions regarding this campaign, please contact your Region representative.

VII. APPENDIX

A. CAMPAIGN DESIGNATION DECODER

