

TECHNICAL INSTRUCTIONS

FOR

SAFETY RECALL CAMPAIGN E01

CERTAIN 2014 MODEL YEAR AVALON, CAMRY, HIGHLANDER & SIENNA 2GR ENGINE FUEL DELIVERY PIPE SUB-ASSEMBLY

All dealership associates involved in the campaign process are required to successfully complete E-Learning course SC13A. To ensure that all vehicles have the repair performed correctly; technicians performing this recall repair are required to currently hold at least one of the following certifications levels:

- Toyota Certified (any classification)
- Toyota Expert (any classification)
- Master
- Master Diagnostic Technicians

I. OPERATION FLOW CHART

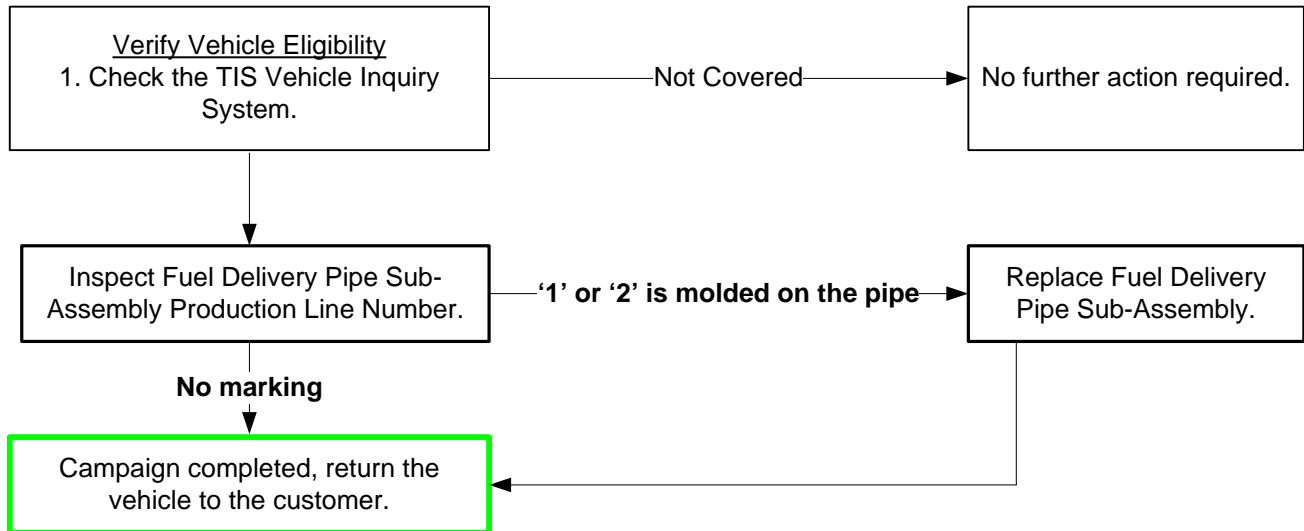

II. IDENTIFICATION OF AFFECTED VEHICLES

NOTE:

- Check the TIS Vehicle Inquiry System to confirm the VIN is involved in this SSC and that the campaign has not already been completed prior to dealer shipment or by another dealer.
- **TMS warranty will not reimburse dealers for repairs conducted on vehicles that are not affected or were completed by another dealer.**

III. PREPARATION

A. PARTS

Part Number	Part Description	Quantity
23870-0P011	Fuel delivery pipe	1
90301-07033	Injector "O"-Rings	6
23291-23010	Injector vibration insulator	6
17176-0P021	Air surge tank gasket	3
22271-0P020	Throttle body gasket	1

Parts are only needed if the vehicle fails the inspection

B. TOOLS & EQUIPMENT

- Flash light
- Small Inspection Mirror
- Borescope (optional)
- Standard Hand Tools
- Torque Wrench
- Techstream

IV. BACKGROUND

In the subject vehicles, the Bank 1 (cowl side) fuel delivery pipe end cap could have been insufficiently welded during the manufacturing process. This condition can lead to a fuel leak in the engine compartment. Fuel leakage in the presence of an ignition source, could increase the risk of a vehicle fire.

V. INSPECTION COMPONENTS

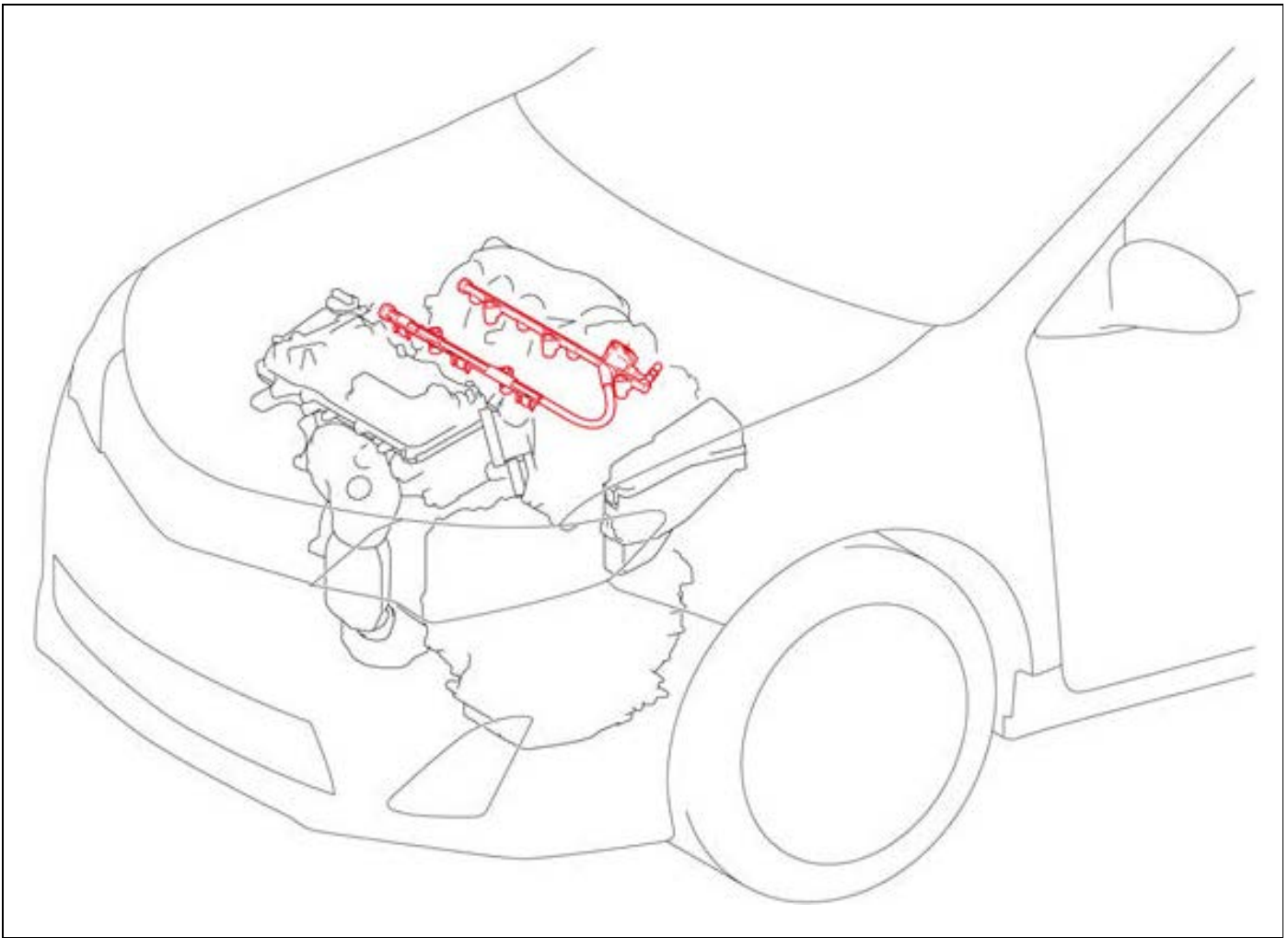

VI. WORK PROCEDURE

1. INSPECT FUEL DELIVERY PIPE

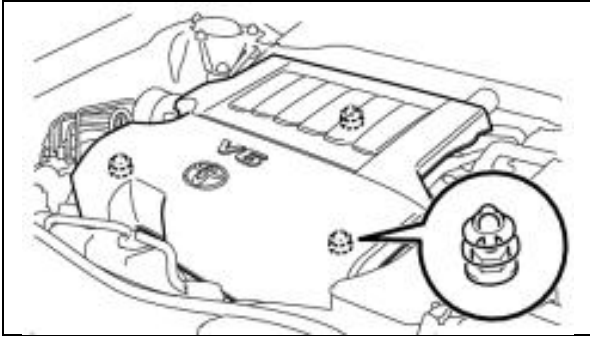

2. REMOVE THE V-BANK COVER SUB ASSEMBLY

Avalon, Camry and Highlander

- a) Hold the rear of the V-bank cover sub-assembly and raise it to disengage the 2 retainers on the front side.
- b) Raise the V-bank cover sub-assembly to disengage the retainer on the rear side and remove the V-bank cover sub-assembly.

Sienna

- a) Hold the front of the V-bank cover sub-assembly and raise it to disengage the 2 retainers on the front of the V-bank cover sub-assembly.
- b) Continue to raise the V-bank cover sub-assembly to disengage the 2 retainers on the rear of the V-bank cover sub-assembly and remove the V-bank cover sub-assembly.

NOTE: Attempting to disengage both front and rear retainers at the same time may cause the V-bank cover sub-assembly to break.

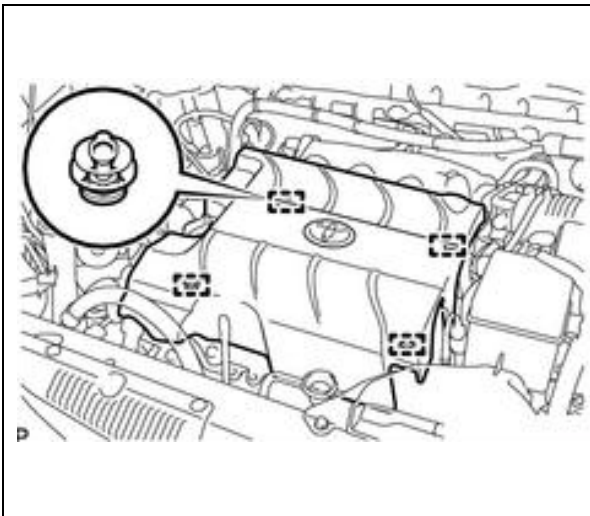

3. INSPECT THE No. 2 FUEL DELIVERY PIPE PRODUCTION LINE NUMBER

a) Using a mirror (or borescope) inspect the No. 2 fuel delivery pipe production line number.

NOTE: The production line number is located next to the injector at the front of the cylinder head.



- It is very important to look at this area very carefully at multiple angles with good lighting.
- The mirror needs to fit directly under the fuel pipe.

Fuel Delivery Pipe End Cap

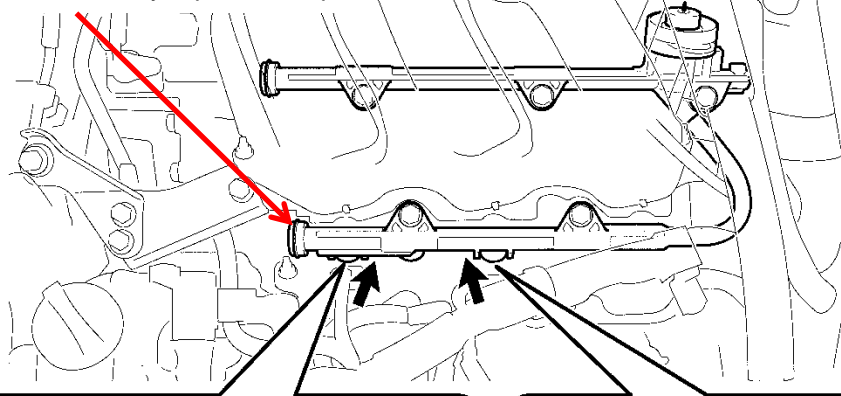

Correct

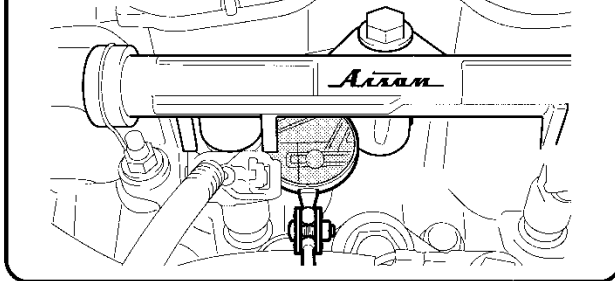

Incorrect

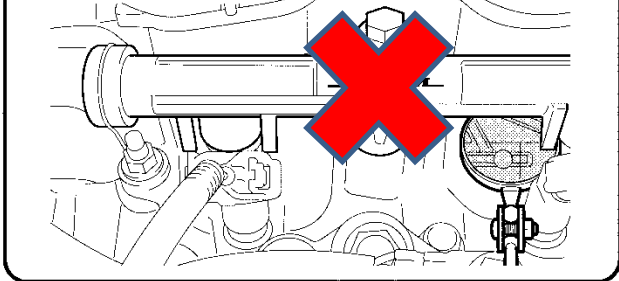

S80001bS

RESULTS

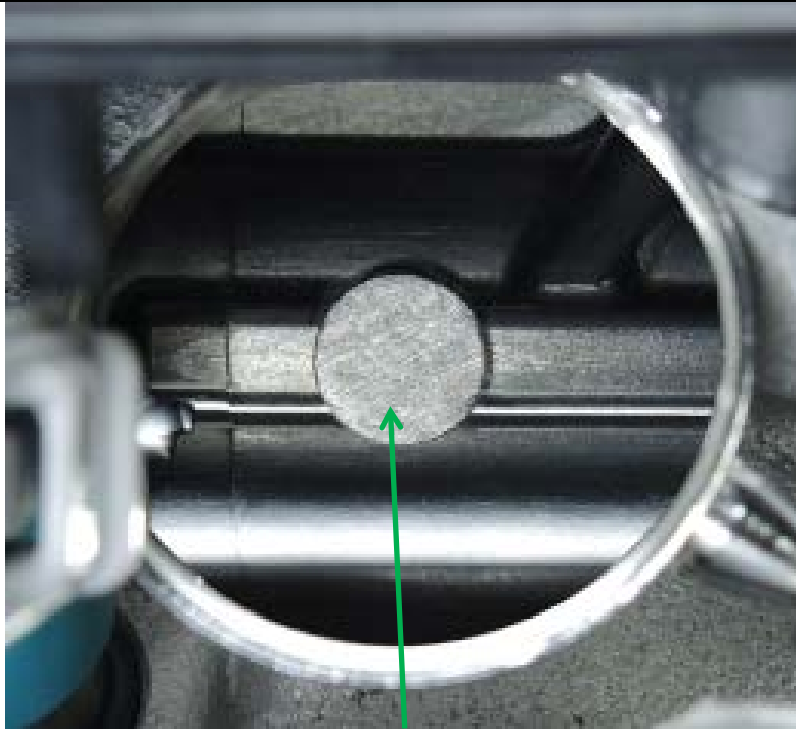

OK

Blank

If there is no number on the fuel delivery pipe **Proceed to Step 4.**

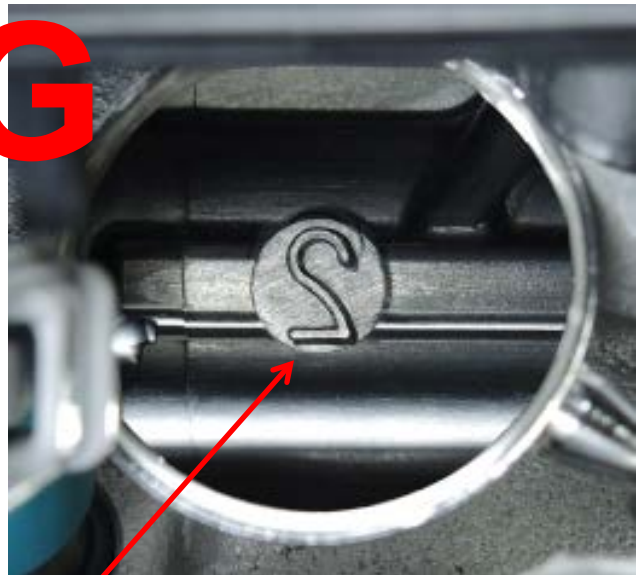
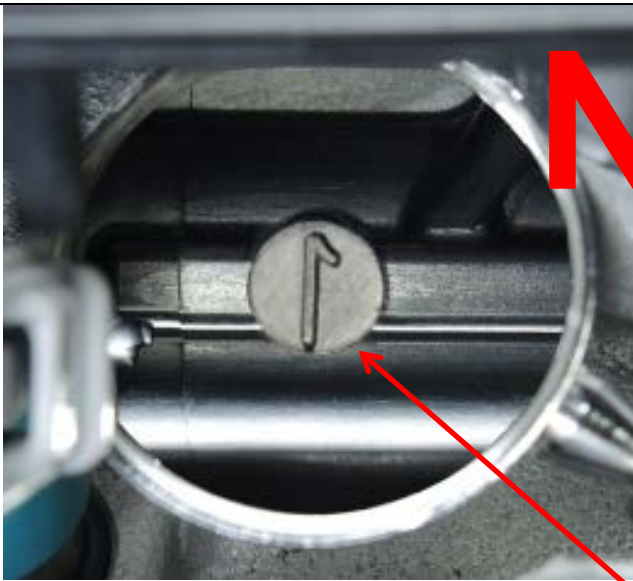

NG

If the fuel delivery pipe has a **1** or **2** molded on to the pipe
Proceed to Section VII Fuel Delivery Pipe Replacement.

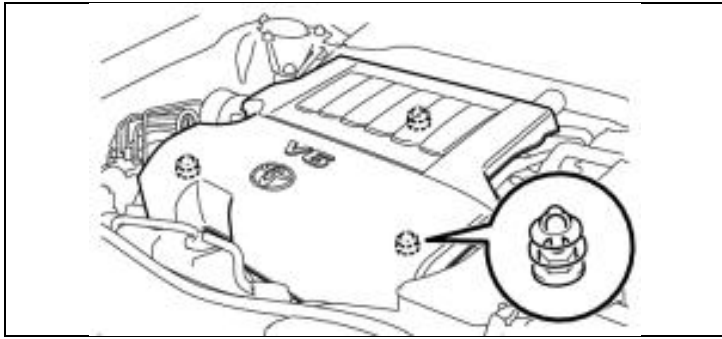

4. REINSTALL THE V-BANK COVER SUB ASSEMBLY

Avalon, Camry and Highlander

- a) Fit the 3 retainers and install the V-bank cover sub-assembly.
- b) Campaign complete.

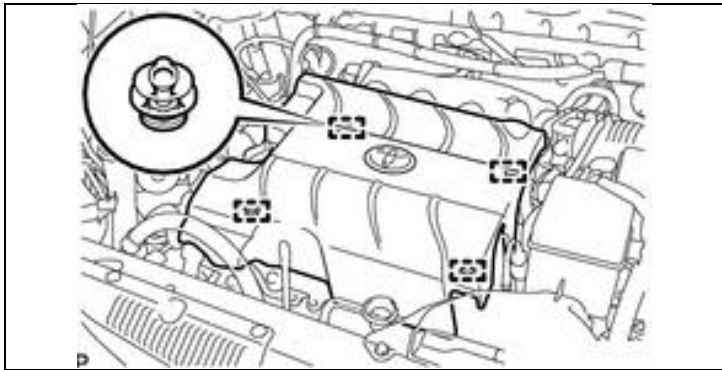

Sienna

- a) Fit the 4 retainers and reinstall the V-bank cover sub-assembly.
- b) Campaign complete.

VII. FUEL DELIVERY PIPE REPLACEMENT

A. REPLACEMENT COMPONENTS

for AVALON,CAMRY,HIGHLANDER

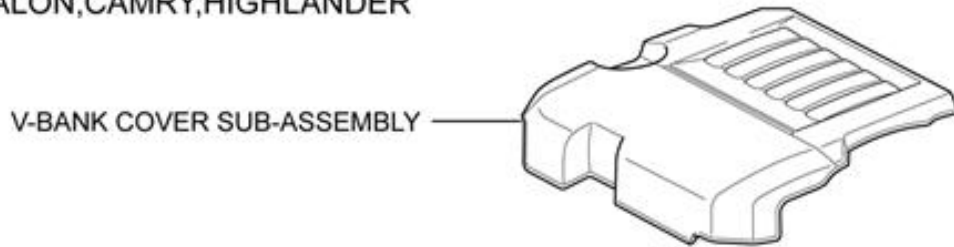

for AVALON,CAMRY

NO.2 VENTILATION HOSE

MASS AIR FLOW
METER CONNECTOR

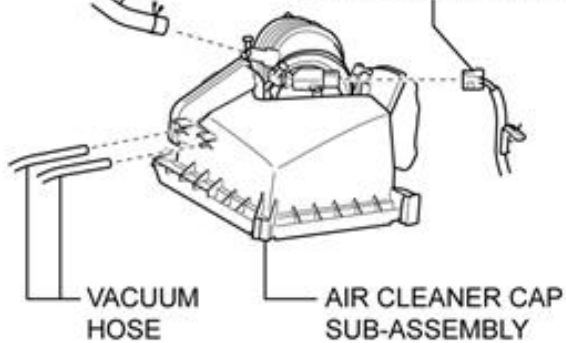

for HIGHLANDER

FUEL VAPOR FEED
HOSE

NO.2
VENTILATION
HOSE

MASS AIR FLOW
METER CONNECTOR

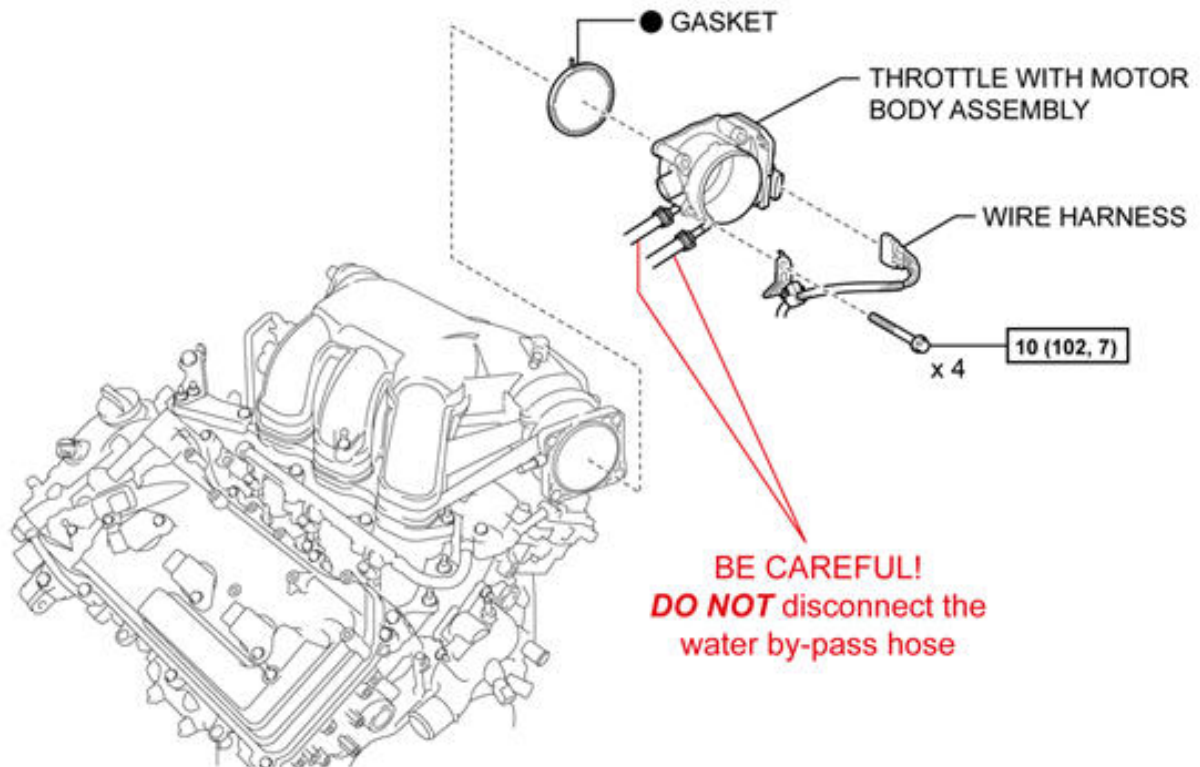
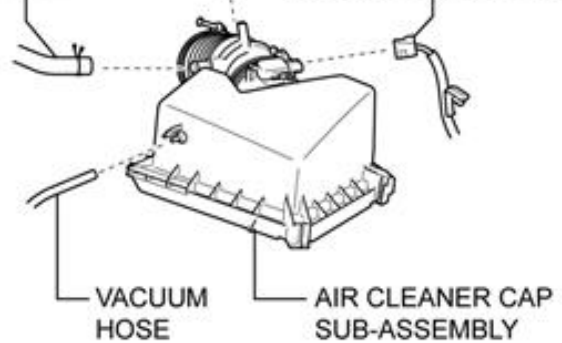

N*m (kgf*cm, ft*lb) : Specified torque

for SIENNA

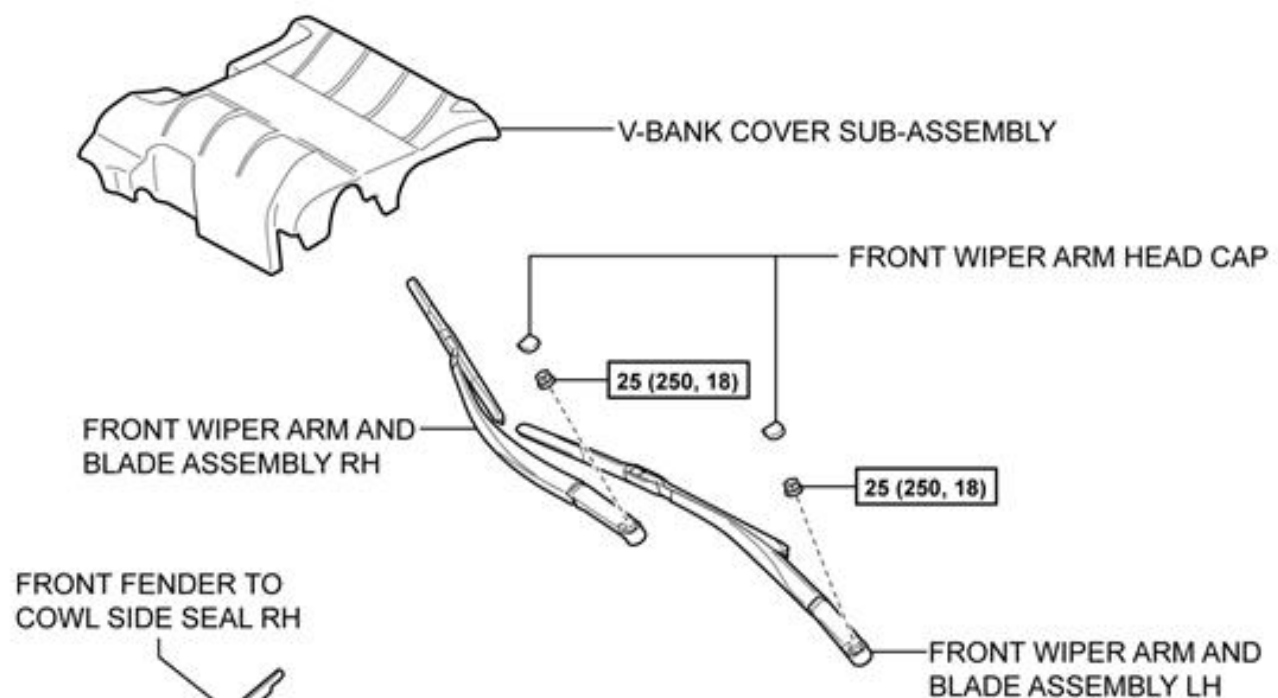

BE CAREFUL!
DO NOT remove the front fender to cowl side seal from the vehicle

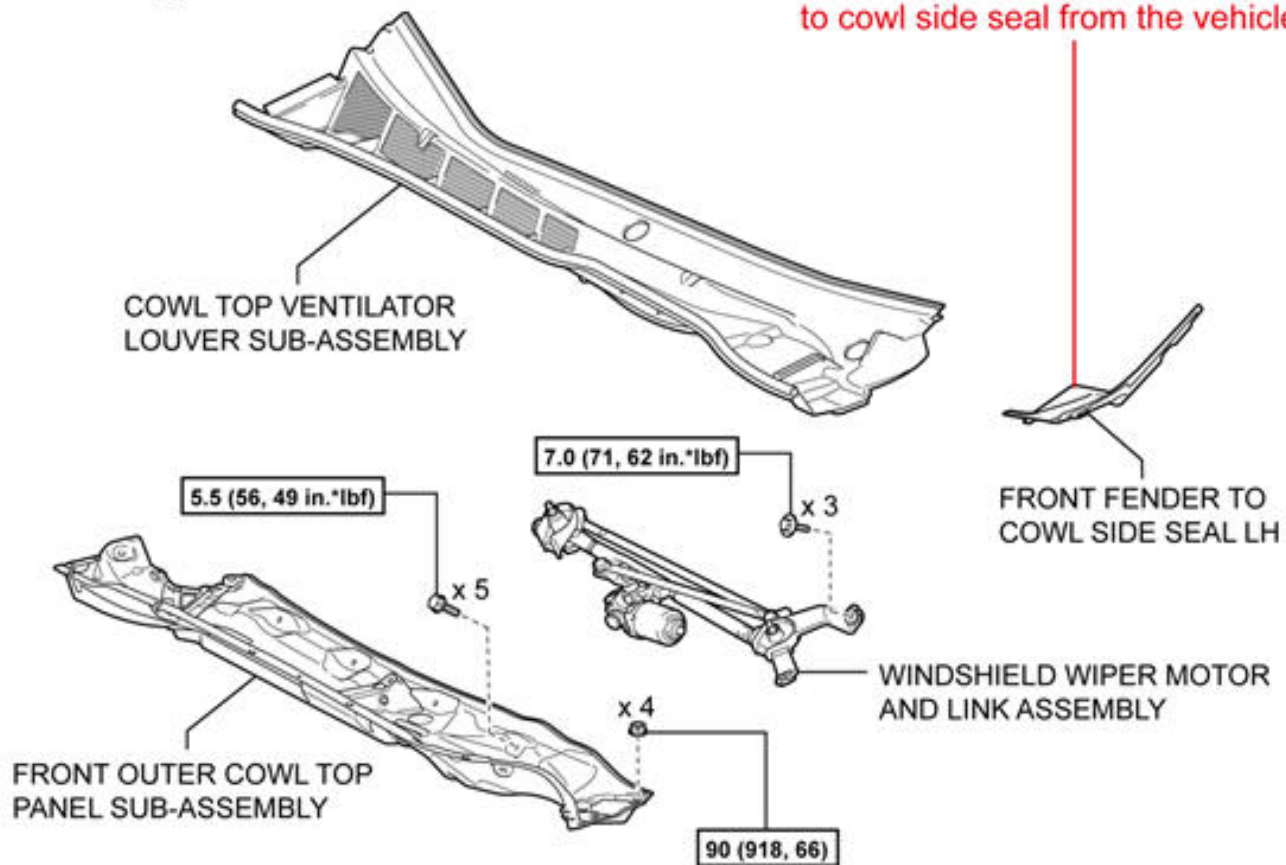

N*m (kgf*cm, ft*lbf) : Specified torque

for SIENNA

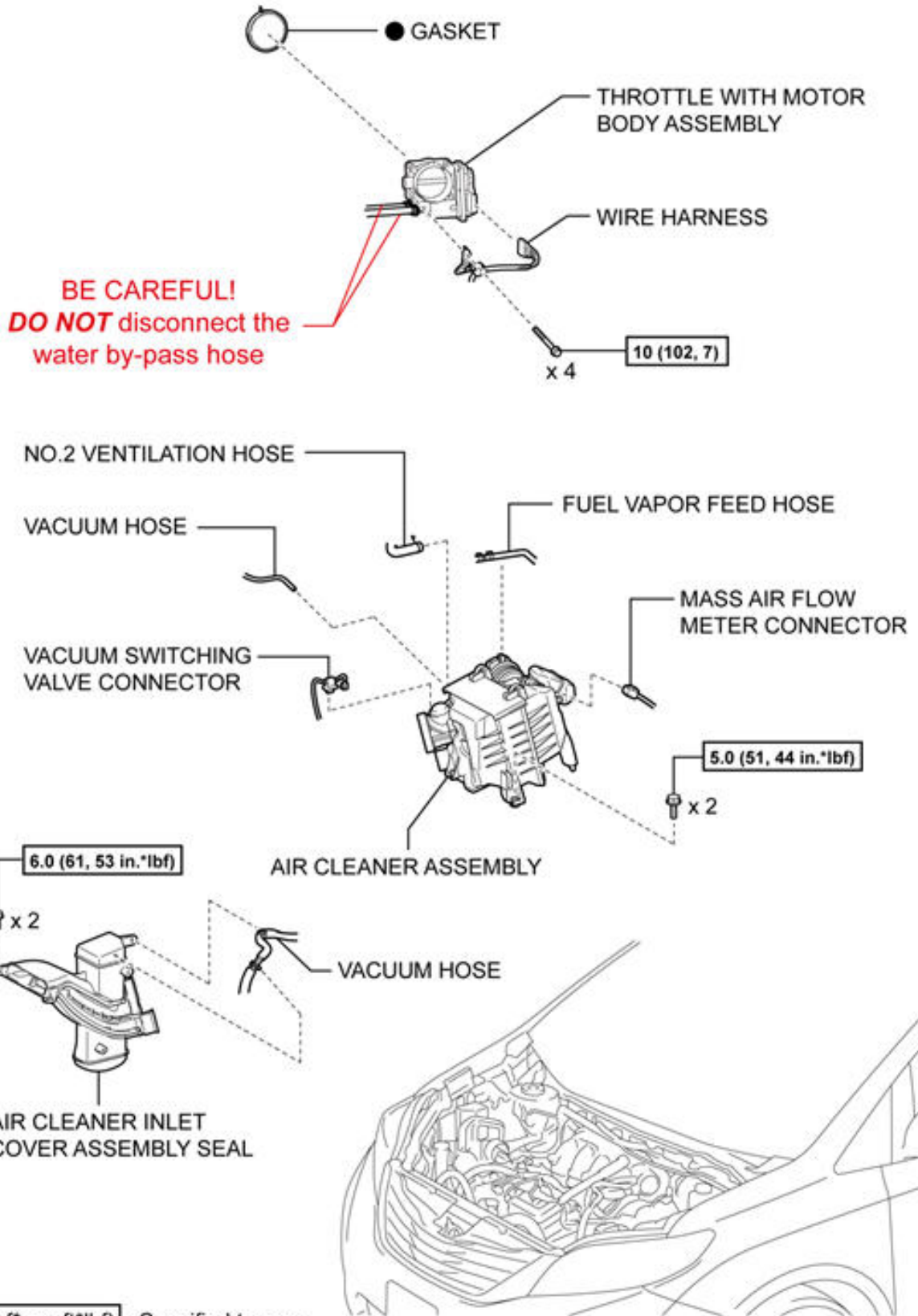

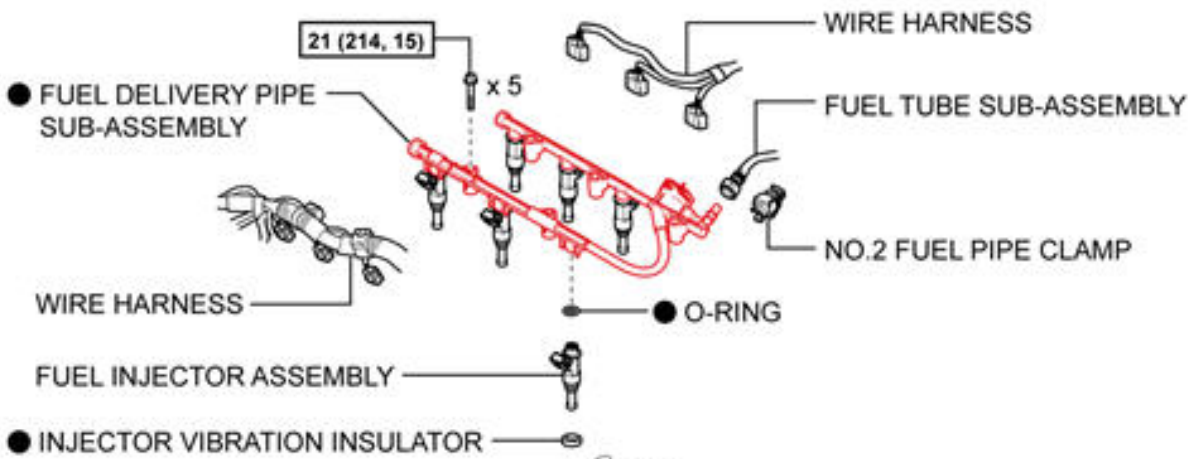
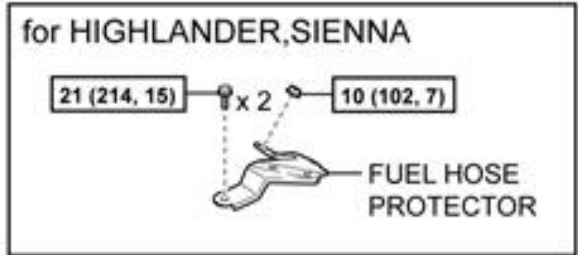
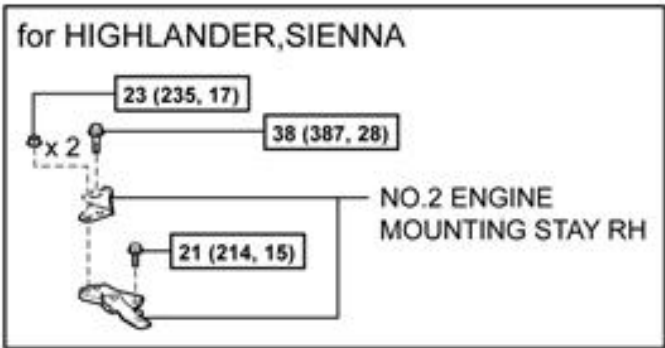
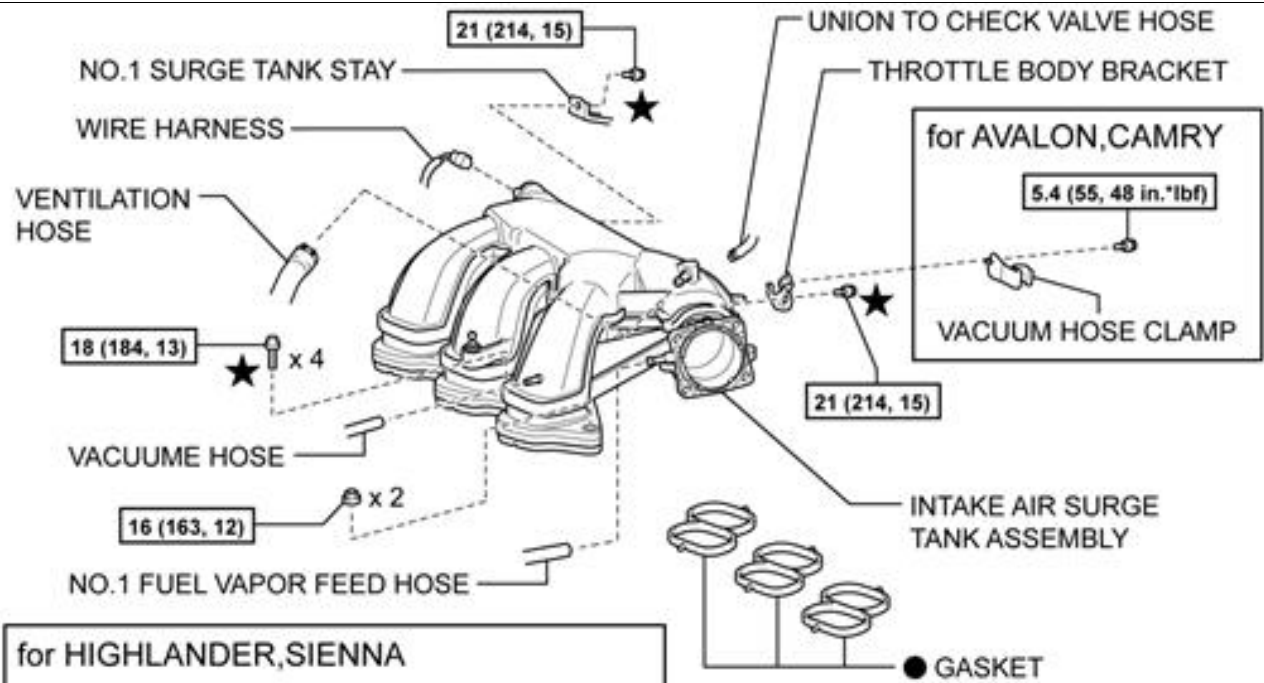

N*m (kgf*cm, ft*lbf) : Specified torque

● Component to be replaced

★ DO NOT apply oil

S80023aS

C. WORK PROCEDURE

- a) Check system for DTC's.



This campaign only covers the inspection and replacement of the fuel delivery pipe if needed. No other components in the engine management or fuel system are covered by this campaign.

Refer to the Technical Information System (TIS), using the applicable vehicle and model year.

Fuel Delivery Pipe Removal

Avalon Camry Highlander Sienna

Fuel Delivery Pipe Installation

Avalon Camry Highlander Sienna

NOTE: Do not remove the coolant lines from the Throttle Body. Remove the Throttle Body from the Surge Tank and place it out of the way.

The information in TIS is for replacing the fuel injectors. However, the operation is the same to remove and replace the fuel delivery pipe but **reusing the old injectors.**

When replacing the fuel delivery pipe mark each injector so they are reinstalled into the same cylinder location. (i.e. injector for cylinder #1 is reinstalled on to the fuel delivery pipe for cylinder #1)

- b) After replacement of the fuel delivery pipe is completed. Active test the fuel pump using Teachstream and check for fuel leaks around the injectors and fuel delivery pipe.
- c) Start the engine and check system for DTC's.
- d) Test drive vehicle.

◀ VERIFY REPAIR QUALITY ▶

- Check for fuel leaks and odors around the injectors and fuel delivery pipe.

If you have any questions regarding this campaign, please contact your area representative.

VIII. APPENDIX

A. CAMPAIGN DESIGNATION DECODER

