



SERVICE BULLETIN

SB1272

ADDRESSEES	: ABC Customer Care and Parts Source Owners and operators of coaches listed under 'Application'
VEHICLE MODEL	: TD925US
MANUAL SECTION	: 12.6 Axles – front axle
BULLETIN TYPE	: Safety Recall NHTSA 14V-569
DATE	: October 20th, 2014
SUBJECT	: To inspect LH and RH steering knuckle carriers of front axle
TERMS & CONDITIONS	: Refer to the warranty section further in this Bulletin.

APPLICATION:

The recall campaign, subject of this Bulletin, is applicable to following units:

Model	VIN
TD925US (non-steered tag axle)	42395, 42465 → 42608, 42616 → 42627
TD925US (with steered tag axle)	42630

DESCRIPTION:

- Van Hool NV has determined that a defect which relates to motor vehicle safety may exist in the above-mentioned coaches.
- The material of certain front steering knuckle carriers do not meet the minimum requirements. Early fatigue may lead to cracks and finally loss of functionality. The driver might feel some vibrations in the steering wheel. In case of total failure however, a wheel could separate from the coach.
- Owners and operators of the affected units should first identify and register the LH and RH steering knuckle carriers and, if necessary, change the affected steering knuckle carrier(s).

Refer to the procedures in this Service bulletin for instructions. The terms and conditions of the campaign have been detailed in the warranty section.

Continued on next page

MATERIAL:

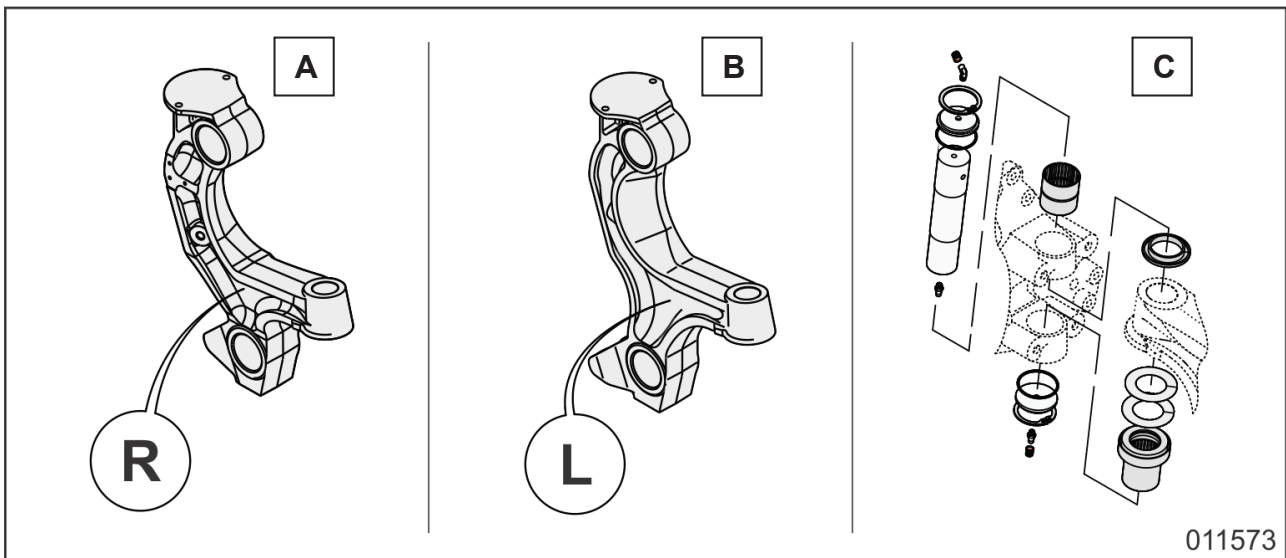

Figure 1: RH/LH steering knuckle carriers and king-pin repair kit

VH reference	Description	Figure 1	Qty.
10737763	RH steering knuckle carrier	A	1
10737761	LH steering knuckle carrier	B	1
N442056042	King-pin repair kit	C	1
660207210	Shock absorber fixing nut (M16x1.5 grade 8)	-	1*
L019023413	Brake carrier fixing screw	-	6*
624317270	Rubber bushings of suspension arms, steering knuckle side	-	4*
11431005	Articulation assembly bolt (includes screw, nut and two special spring washers)	-	2*
660207214	Fixing nut (M16x1.5 grade 10) of upper suspension arms	-	4*
660207287	Fixing nut (M18x1.5 grade 10) of lower suspension arms	-	4*
10543971	Cotter pin for castle nut of tie-rod	-	1*

*Quantity suited for one side

Continued on next page

PREPARATIONS:

- Park the vehicle on a level-surfaced pit with the front wheels straight. Apply the parking brake, stop the engine, switch off all systems and turn off the battery master switch on the dashboard. When using portable post lifts (always use 6 post lifts) instead of a service pit, always lower the suspension first.
- Turn off the mechanical battery switch.
- Put a “DO NOT OPERATE” tag on the instrument panel before beginning any inspection or performing any repair.
- Place chocks in front of and behind the drive axle wheels.
- Read the entire procedure before beginning to work.



WARNING!

Observe safe shop practices at all times.

PROCEDURE:

Step	Action
1	Identify the RH and LH steering knuckle carriers of the front axle.
2	Register the RH and LH steering knuckle carriers via the “Vehicle Check Form” to determine if a steering knuckle carrier is affected.
3	Change an affected steering knuckle carrier.
4	Register the RH and LH steering knuckle carriers of the front axle again via the “Vehicle Check Form” (refer to step 2 for procedure).

STEP 1: Identify the RH and LH steering knuckle carriers of the front axle

1. General:

If identification codes are not immediately visible, clean the area with a stiff wire brush to remove dirt and residue.

NOTE: If the steering knuckle carrier is not affected, repaint the cleaned area with a primer for cast iron to prevent rusting.

2. Identify the steering knuckle carriers of the front axle:

The steering knuckle carriers can be cast by two foundries. The location of the identification codes (refer to figures 2A and 2B) and the shape of the carrier end exterior is different according to the foundry.

Follow all the instructions below for identification of RH and LH steering knuckle carriers.

Continued on next page

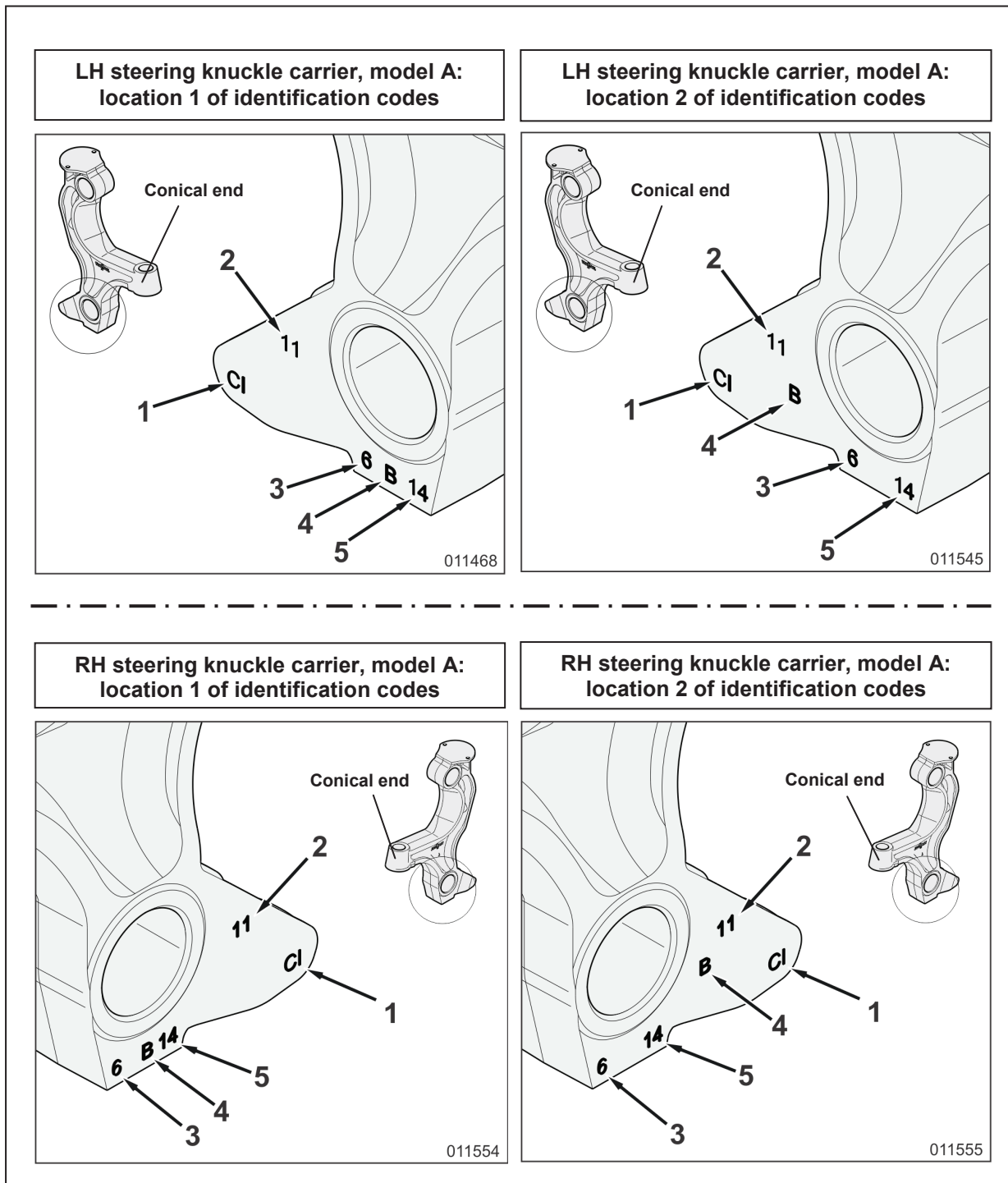

Figure 2A: Identification of model A steering knuckle carriers (location may vary)

1. Foundry initials
2. Cast production year (“11” stands for the year 2011)
3. Cast production day (“6” stands for the 6th day of the month)
4. Cast production month (letter code: “B” stands for “February”)
5. Batch number (“14” stands for batch 14 of the day)

Continued on next page

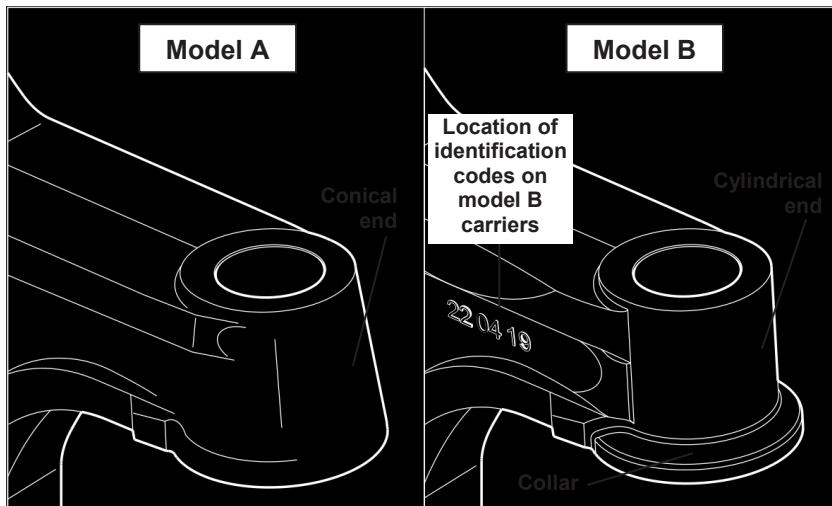

Figure 2B: Shape of carrier end exterior

Step	Action										
A	<p><i>NOTE: For steering knuckle carriers with the identification codes at the bottom, if the foundry initials are not readable, look at the shape of the carrier-end exterior. A conical shaped end has equal value as the foundry initials "C" and "CI".</i></p> <p>Does the RH steering knuckle carrier have "C" or "CI" as foundry initials at the bottom?</p> <ul style="list-style-type: none"> If yes, locate all five identification codes of the RH steering knuckle carrier (refer to figure 2A) and fill out all five codes of the RH steering knuckle carrier in the table below for reference during registration. Fill out "Not readable" in case of not readable codes. If not, fill out the letters "CF" in field (1) of the table. The other fields of the table may remain blank. <table border="1" style="width: 100%; text-align: center;"> <tr> <td>(1)</td> <td>(2)</td> <td>(3)</td> <td>(4)</td> <td>(5)</td> </tr> <tr> <td> </td> <td> </td> <td> </td> <td> </td> <td> </td> </tr> </table>	(1)	(2)	(3)	(4)	(5)					
(1)	(2)	(3)	(4)	(5)							
B	<p><i>NOTE: For steering knuckle carriers with the identification codes at the bottom, if the foundry initials are not readable, look at the shape of the carrier-end exterior. A conical shaped end has equal value as the foundry initials "C" and "CI".</i></p> <p>Does the LH steering knuckle carrier have "C" or "CI" as foundry initials at the bottom?</p> <ul style="list-style-type: none"> If yes, locate all five identification codes of the LH steering knuckle carrier (refer to figure 2A) and fill out all five codes of the LH steering knuckle carrier in the table below for reference during registration. Fill out "Not readable" in case of not readable codes. If not, fill out the letters "CF" in field (1) of the table. The other fields of the table may remain blank. <table border="1" style="width: 100%; text-align: center;"> <tr> <td>(1)</td> <td>(2)</td> <td>(3)</td> <td>(4)</td> <td>(5)</td> </tr> <tr> <td> </td> <td> </td> <td> </td> <td> </td> <td> </td> </tr> </table>	(1)	(2)	(3)	(4)	(5)					
(1)	(2)	(3)	(4)	(5)							

STEP 2: Register RH and LH steering knuckle carriers of the front axle

Should you require assistance with the registration, please contact ABC Companies Tech Support at 877-427-7278.

Step	Action
2.1	Note vehicle identification number (only last five digits) and mileage.

Continued on next page

2.2

Go to www.vanhool.be/SB1272. Fill in your personal data and click on “Register”.



Figure 3

You will receive an email with a link to the “Vehicle Check Form”.

2.3

Open the email and click on the link.

2.4

Fill out vehicle identification number (VIN) and mileage. Select the identification codes of the steering knuckle carriers.

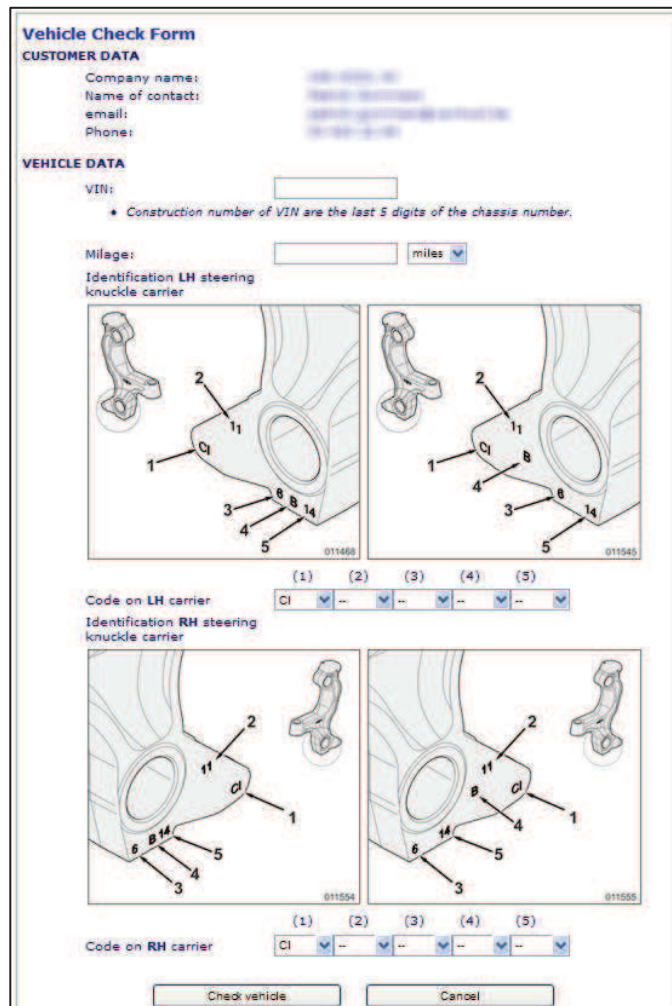

Figure 4

2.5

Click on “Check vehicle” to determine if a steering knuckle carrier is affected.

Continued on next page

2.6	<p>Are one or both steering knuckle carriers affected?</p> <ul style="list-style-type: none"> • If yes, a message on the screen appears telling you the steering knuckle carrier(s) is/are affected and replacement is mandatory. ABC Companies will contact you as soon as possible to make further appointments (distribution of parts, need for assistance, ...). • If not, no further actions required. <p>Thanks for your cooperation.</p>
------------	-------------------------------------------------------------------------------------------------------------------------------------------------------------------------------------------------------------------------------------------------------------------------------------------------------------------------------------------------------------------------------------------------------------------------------------------------------------------------

STEP 3: Change an affected steering knuckle carrier

1. General:

This job has to be carried out by a technician experienced in suspension systems. If you deem yourself not qualified, please contact ABC Companies Tech Support at 877-427-7278.

2. Special tools, equipment or services:

This job requires the use of special tools:

VH reference	Description
10695670	Tool set to free suspension arms from steering knuckle carrier
11432697	Tool set to pull articulation assembly shaft out of steering knuckle carrier

3. To remove steering knuckle carrier:



Step	Action
3.1	Ensure chocks are placed in front of and behind the drive axle wheels. Jack up the vehicle until the front wheels clear the ground. Support the chassis with stands or wooden blocks.
3.2	Discharge all the air from the air system by opening the drain valves of all air tanks.
3.3	Remove the road wheel at the side of the steering knuckle carrier that is to be removed.
3.4	<p>Disconnect the leveling valve connection rod from its lower attachment on the front axle. Pull down the leveling valve actuating lever to deflate the air bellows.</p> <div style="text-align: center;">  </div> <p style="text-align: right;">004317</p>

Figure 5: Leveling valve

- 1. Actuating lever**
- 2. Connection rod**

Continued on next page

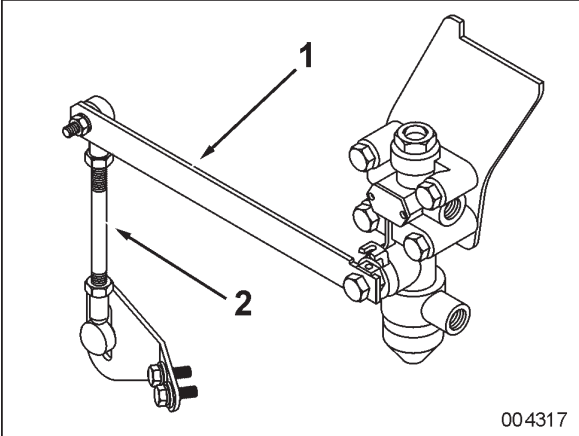
3.5	Disconnect the brake chamber air hose.
3.6	<p> WARNING! The brake caliper/carrier assembly is very heavy, take great care in handling! Do not fasten any lifting device to the brake pad retainer since it can be damaged. Be sure it is well supported, before undoing the fixing screws.</p> <p>Remove the brake caliper/carrier assembly from the steering knuckle (refer to the Knorr-Bremse Service manual in the appropriate Van Hool Maintenance Manual for brake caliper/carrier assembly removal instructions).</p>
3.7	<p> WARNING! The wheel flange/brake disc assembly is very heavy, take great care in handling! Be sure it is well supported, before undoing the fixing screws.</p> <p>Remove the twelve screws retaining the wheel flange/brake disc assembly to the hub unit and remove the wheel flange/brake disc assembly.</p>  <p style="text-align: right;">011575 Figure 6</p>
3.8	Disconnect the tie-rod by removing the ball-pillar nut and drawing the ball-pillar out of the tie-rod arm.
3.9	Remove the king-pin (outlined further on under "To remove king-pin") and remove the steering knuckle/hub assembly.
3.10	<p>Unscrew the outer nuts of the suspension arms upper tie-rod. Screw the inner nuts of the upper tie-rod as far as possible away from the suspension arms. Pull the upper tie-rod out of the holes in the suspension arms.</p>  <p style="text-align: right;">011551 Figure 7</p>

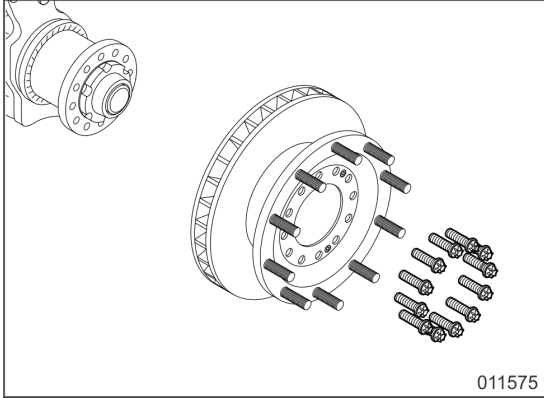
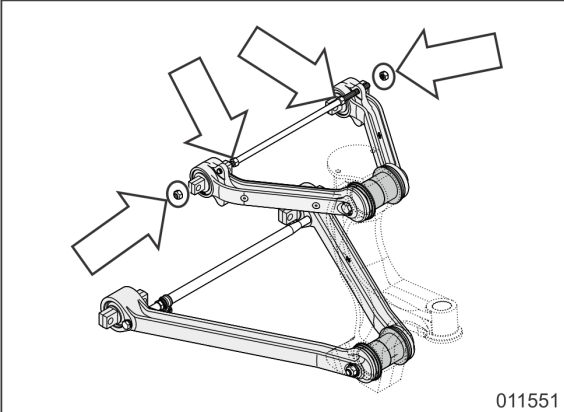
Continued on next page



<p>3.11</p>	<p>Slacken the bolts at the front and rear of the suspension arms lower tie-rod. Because there is not enough space to remove the bolts right away, the bolts and the lower tie-rod will be removed further on in step 3.16.</p> <div data-bbox="571 322 1121 719" data-label="Image"> </div> <p style="text-align: right;">011552 Figure 8</p>
<p>3.12</p>	<div data-bbox="360 772 443 857" data-label="Image"> </div> <p>WARNING! Make sure that the steering knuckle carrier assembly is well supported.</p> <p>Roll a trolley lift under the steering knuckle carrier assembly.</p>
<p>3.13</p>	<p>Disconnect the shock absorber from the steering knuckle carrier.</p>
<p>3.14</p>	<p>Remove the screws securing the air bellows piston to the steering knuckle carrier.</p>
<p>3.15</p>	<p><i>NOTE: Make note of the number and the position of the camber adjustment spacers, for re-use during assembly.</i></p> <p>Remove the nuts of the four bolts securing the upper suspension arms to the chassis, then remove the four nuts of the lower suspension arms. To keep the opposite axle half in place, reinstall the fixing bolts of the lower suspension arms.</p> <div data-bbox="608 1207 1158 1603" data-label="Image"> </div> <p style="text-align: right;">011528 Figure 9</p>
<p>3.16</p>	<p>Carefully withdraw the steering knuckle carrier assembly from under the vehicle. Unscrew the bolts at the front and the rear of the suspension arms lower tie-rod and remove the lower tie-rod when the steering knuckle carrier is withdrawn a little from under the vehicle.</p>
<p>3.17</p>	<p>Free the suspension arms from the steering knuckle carrier (outlined further on under “To free suspension arms from steering knuckle carrier”).</p>

Continued on next page

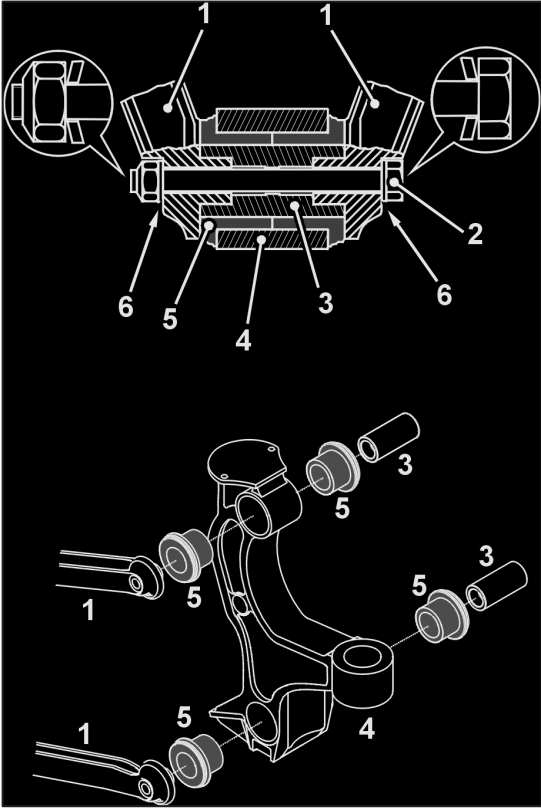
4. To install new steering knuckle carrier:

Step	Action
4.1	Install the new rubber bushings and the articulation assembly shafts into the steering knuckle carrier as follows: <ol style="list-style-type: none"> Degrease the steering knuckle carrier bore. Wipe with a clean cloth. Apply clean water (no soapy water) to the rubber bushings and the bore in the steering knuckle carrier to ease assembly. Push both rubber bushings and the articulation assembly shaft into the bore of the steering knuckle carrier.
4.2	<div style="display: flex; align-items: flex-start;"> <div style="margin-right: 10px;">  </div> <div> <p>CAUTION!</p> <p>Suspension arms are not interchangeable. An upper suspension arm is located at the correct position when the snap-ring of the flexible ball-joint is orientated to the front of the vehicle and the cast rib with the hole to receive the tie rod is at the top. A lower suspension arm is located at the correct position when the snap-ring of the flexible ball-joint is orientated to the rear of the vehicle.</p> </div> </div> <p>Push the suspension arms in the articulation assembly shaft. If necessary, use a soft hammer.</p>
4.3	<p>Install the new articulation assembly bolts. The “hollow” side of the spring washers must be directed towards the suspension arm (refer to figure 10). Hand-tighten the nut of the articulation assembly bolts.</p> <div style="text-align: center;">  </div> <div style="margin-top: 10px;"> <p>Figure 10: Articulation joint, steering knuckle carrier side</p> <ol style="list-style-type: none"> 1. Suspension arm 2. Articulation assembly bolt (with self-locking nut) 3. Articulation assembly shaft 4. Steering knuckle carrier 5. Rubber bushing 6. Special spring washer </div>

Continued on next page

4.4	Using a trolley lift, offer the steering knuckle carrier assembly under the vehicle.
4.5	<p>Install the lower tie-rod before the steering knuckle carrier assembly is completely in position under the vehicle. Installation at a later stage is not possible!</p> <p> CAUTION! Make sure that the recessed section of the lower tie-rod face the relay rod of the front steering system.</p> <div data-bbox="486 450 1358 891" data-label="Image"> </div>
4.6	<p> CAUTION! If the fixation bolts cannot be inserted freely in the suspension arms bolt holes, the tie-rod length must be adjusted until the bolt holes coincide with the holes in the chassis. This to avoid pre-load on the ball-joints when tightening the bolts securing the suspension arms to the chassis.</p> <p>Install the suspension arms tie-rods and adjust the tie-rods length:</p> <ul style="list-style-type: none"> • For the lower tie-rod: loosen bolt (1) and the nut of clamp bolt (2), and turn hexagon (3) to adjust the length. Tighten bolt (1) to a torque of $140 + 10 \text{ Nm}$ ($105 + 5 \text{ ft.lbf}$), nut of clamp bolt (2) to a torque of $50 \pm 5 \text{ Nm}$ ($35 \pm 4 \text{ ft.lbf}$) <div data-bbox="555 1335 1185 1789" data-label="Image"> </div> <ul style="list-style-type: none"> • For the upper tie-rod: loosen the outer nuts and turn the inner nuts to adjust the length. Tighten the nuts of the upper tie rod to a torque of $110 \pm 15 \text{ Nm}$ ($80 \pm 10 \text{ ft.lbf}$).

Continued on next page

<p>4.7</p>	<p>Starting with the upper suspension arms, secure the suspension arms to the chassis with new nuts. Install the camber adjustment spacers as found during the removal. Refer to figure 13 for the correct spacer orientation.</p> <div data-bbox="429 309 895 647" data-label="Image"> </div> <p>Figure 13: Camber adjustment spacers must be orientated so that the openings are horizontal and to the outside</p>
<p>4.8</p>	<p>Finally tighten the bolts securing the suspension arms to the chassis.</p> <ul style="list-style-type: none"> • Tightening torque for nuts of upper suspension arms (M16x1.5 grade 10): 280 + 30 Nm (205 + 20 ft.lbf) • Tightening torque for nuts of lower suspension arms (M18x1.5 grade 10): 390 ± 60 Nm (285 ± 40 ft.lbf).
<p>4.9</p>	<p>Secure the air bellows piston to the steering knuckle carrier. Tighten the screws to a torque of 70 ± 10 Nm (52 ± 7 ft.lbf).</p>
<p>4.10</p>	<p>Secure the steering knuckle/hub assembly with a new king-pin to the steering knuckle carrier (outlined further on under "To install king-pin").</p>
<p>4.11</p>	<p>Reconnect the tie-rod. Tighten the castle nut to a torque of 265 ± 15 Nm (195 ± 10 ft.lbf). Install a new cotter pin.</p>
<p>4.12</p>	<p>Secure the shock absorber to the steering knuckle carrier with a new self-locking nut. Tighten the new self-locking nut to a torque of 100 Nm (70 ft.lbf).</p>
<p>4.13</p>	<p>Jack up the steering knuckle carrier until the suspension arms are horizontal.</p> <p><i>NOTE: Both rubber bushings must be twisted equally strong when the wheel moves up and down. Therefore the articulation assembly bolt may only be fastened while the suspension arms are in horizontal position.</i></p>
<p>4.14</p>	<p>Tighten the articulation assembly bolts to a torque of 300 + 50 Nm (220 + 35 ft.lbf).</p>
<p>4.15</p>	<p>Position the wheel flange/brake disc assembly onto the hub unit in such a way that the screw holes coincide. Install the twelve fixing screws and tighten them crosswise in steps to a torque of 430 ± 30 Nm (320 ± 20 ft.lbf).</p> <div data-bbox="584 1473 1131 1870" data-label="Image"> </div> <p>Figure 14</p> <p>011575</p>

Continued on next page

4.16	Install the brake caliper/carrier assembly on the steering knuckle. Tighten the six new fixing screws of the brake carrier to a torque of 410 Nm (300 ft.lbf) (<i>refer to the Knorr-Bremse Service manual in the appropriate Van Hool Maintenance Manual for brake caliper/carrier assembly installation instructions</i>).
4.17	Refit the brake chamber air hose.
4.18	Adjust the pad to disc running clearance of the disc brake (<i>refer to the Knorr-Bremse Service manual in the appropriate Van Hool Maintenance Manual</i>).
4.19	Reconnect the leveling valve connection rod to its lower attachment.
4.20	Install the road wheel and lower the vehicle (<i>refer to the appropriate Van Hool Maintenance Manual for wheel installation instructions</i>).
4.21	Fill the air system.
4.22	Only if LH steering knuckle carrier assembly of a TD925US with steered tag axle has been changed: reprogram the position of the angle sensor on top of the king-pin to the control unit of the tag axle steering system (outlined further on under "To reprogram the position of the angle sensor to the control unit of the tag axle steering system").
4.23	Check the front axle alignment (<i>refer to the appropriate Van Hool Maintenance Manual for instructions</i>).
4.24	Road-test the vehicle and recheck the front axle alignment.

Continued on next page

5. To remove king-pin:

Special tool	Description
VH A996066146	Press
VH A996206008	Pump
VH A996170183	Drift
VH A996040228	Distance sleeve
VH A996170179	Drift
VH A996350051	Sleeve
VH A996170190	Mandrel

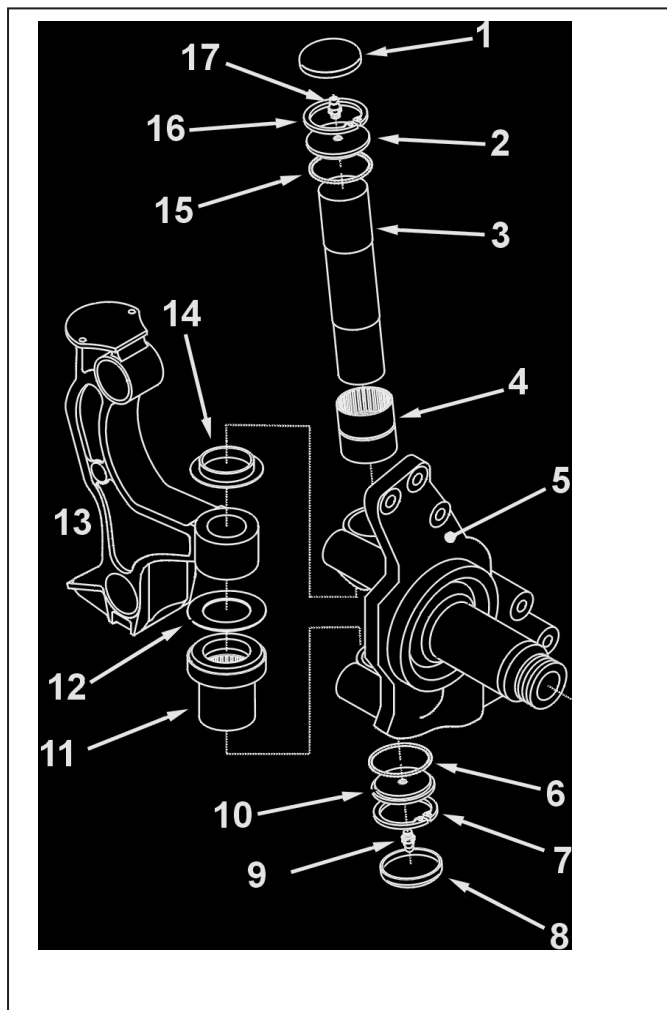

Figure 15: Steering knuckle assembly

1. End cap (if installed)
2. Plug
3. King-pin
4. Upper needle roller bearings
5. Steering knuckle
6. O-ring
7. Snap ring
8. End-cap (if installed)
9. Grease nipple
10. Plug
11. Lower needle roller bearing unit
12. Shim
13. Steering knuckle carrier
14. Grease seal
15. O-ring
16. Snap ring
17. Grease nipple

Step	Action
5.1	Lever off, if installed, king-pin end caps (1-Figure 15) and (8 -Figure 15).
5.2	Remove snap rings (7-Figure 15) and (16-Figure 15).
5.3	Remove plugs (2-Figure 15) and (10-Figure 15). <i>On a TD925US with steered tag axle only: instead of plug (2-Figure 15) an angle sensor for the tag axle steering system is installed on top of the left front king-pin. Remove the angle sensor.</i>
5.4	Remove O-rings (6-Figure 15) and (15-Figure 15)

Continued on next page

- 5.5** Roll the portable press (1) of Figure 16, with the ram at the bottom, under the steering knuckle. Align the ram with the king-pin. Secure steering knuckle (2) with tension belt (3). Connect the hydraulic pump to the press.

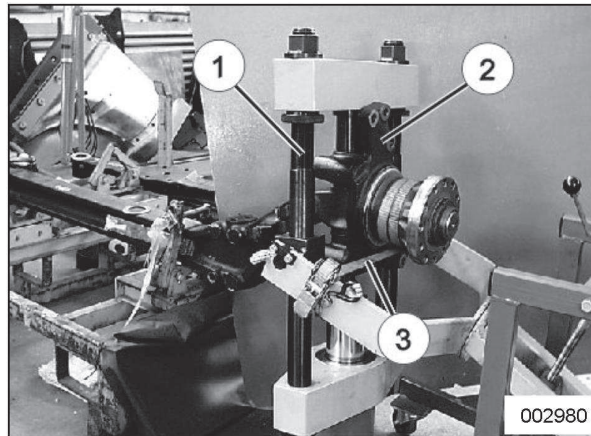

Figure 16:

VH No. press: A996066146
VH No. pump: A996206008

- 5.6** Push down lip (1) of lower needle bearing unit dust shield.

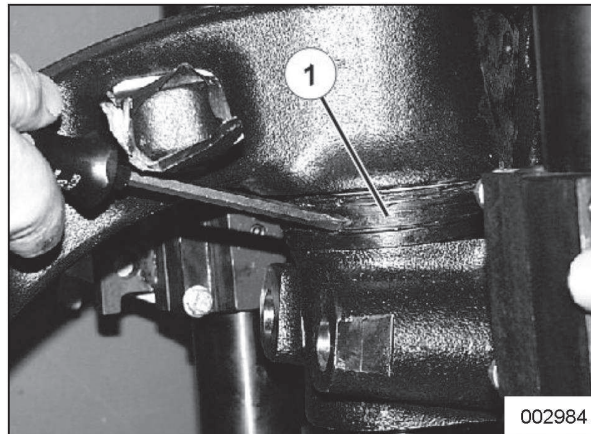

Figure 17

- 5.7** Position drift (1) on top of the ram and distance sleeve (2) on top of the steering knuckle. Press out the king-pin from the bottom.

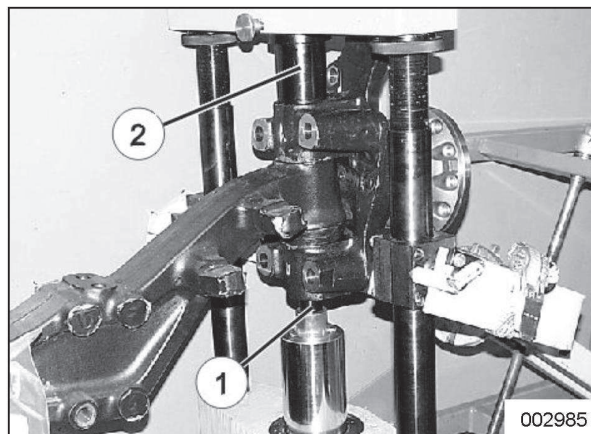
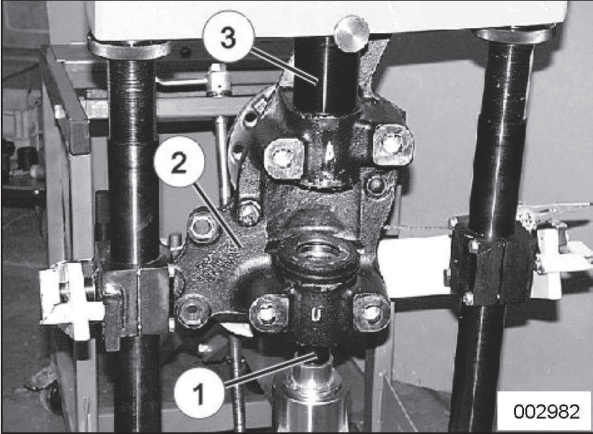
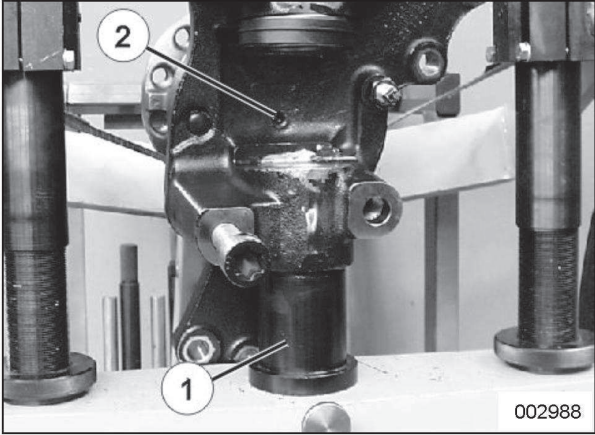
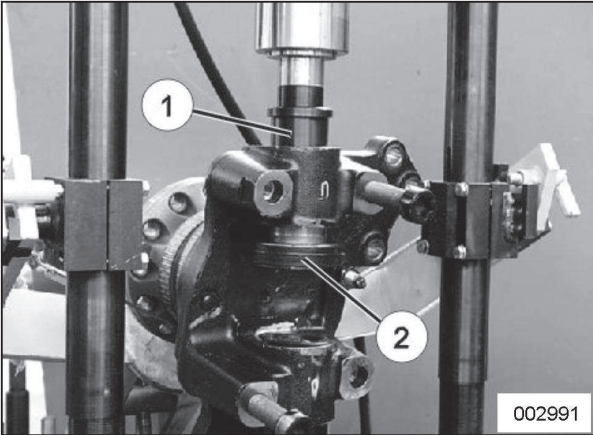

Figure 18:

VH No. drift: A996170183
VH No. sleeve: A996040228

Continued on next page

5.8	Withdraw the king-pin by using a magnet.
5.9	<p>Pump down the press. Remove the drift and replace it by drift A996170179 (1). Apply pressure and center steering knuckle (2) between distance sleeve (3) and drift (1). Remove steering knuckle assembly from steering knuckle carrier.</p>  <p style="text-align: right;">002982 Figure 19</p>
5.10	<p>Proceed as follows to remove the lower needle bearing unit:</p> <p>a) Install steering knuckle (2) upside down onto distance sleeve (1). Install the steering knuckle assembly into the press with the ram on top. Secure the steering knuckle with a tension belt.</p>  <p style="text-align: right;">002988 Figure 20: VH No. drift: A996170183</p> <p>b) Press out lower needle bearing unit (2) by using sleeve (1).</p>  <p style="text-align: right;">002991 Figure 21: VH No. sleeve: A996350051</p>

Continued on next page

5.11

Proceed as follows to remove the upper needle bearings:

- a) With the steering knuckle in the same position as for the removal of the lower needle bearing unit, remove grease seal (1).

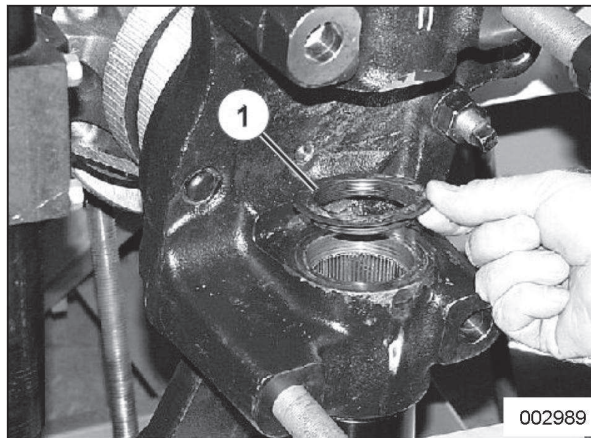

Figure 22

- b) Press out the upper needle bearings using mandrel (2) and sleeve (1).

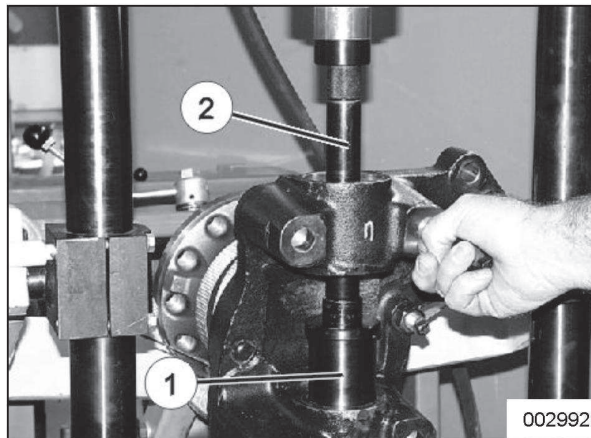

Figure 23:

VH No. mandrel: A996170190
VH No. sleeve: A996350051

Continued on next page

6. To install king-pin:

Special tool	Description
VH A996066146	Press
VH A996206008	Pump
VH A996350049	Sleeve
VH A996350050	Sleeve
VH A996350051	Sleeve
VH A996256001	Pliers
VH A996040228	Distance sleeve
VH A996170179	Drift
VH A996170196	Guide pin
VH A996170197	Magnetic guide
VH A996170190	Mandrel

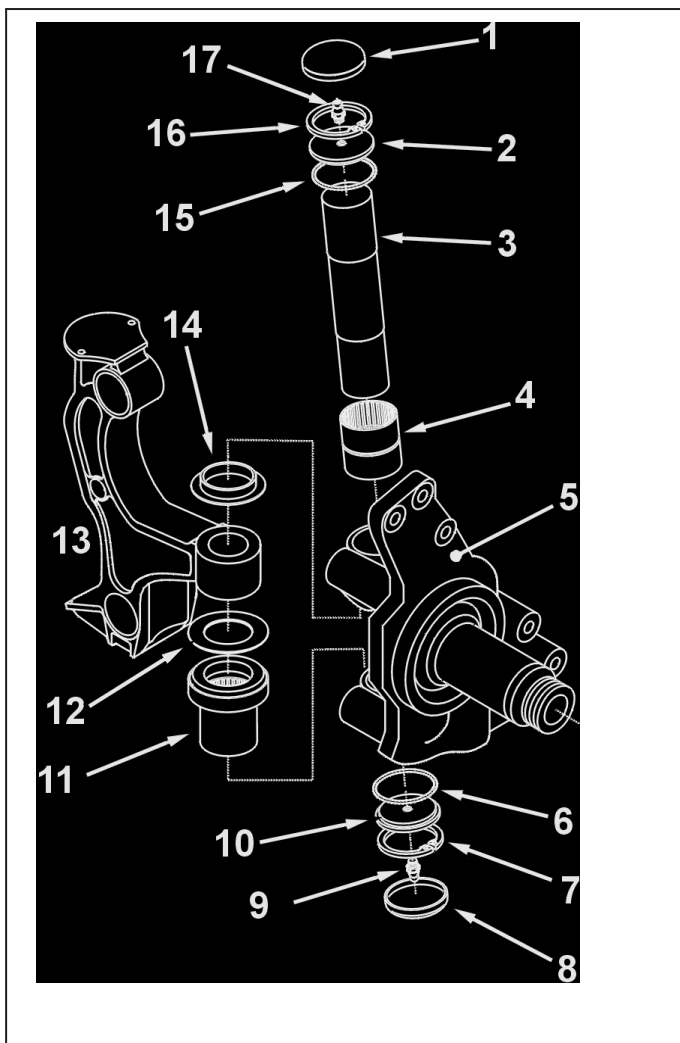

Figure 24: Steering knuckle assembly

1. End cap (if installed)
2. Plug
3. King-pin
4. Upper needle roller bearings
5. Steering knuckle
6. O-ring
7. Snap ring
8. End-cap (if installed)
9. Grease nipple
10. Plug
11. Lower needle roller bearing unit
12. Shim
13. Steering knuckle carrier
14. Grease seal
15. O-ring
16. Snap ring
17. Grease nipple

Continued on next page

Step	Action
6.1	<div data-bbox="359 264 443 349" data-label="Image"> </div> <div data-bbox="469 275 676 315" data-label="Section-Header"> <p>CAUTION!</p> </div> <div data-bbox="469 322 1378 383" data-label="Text"> <p>Before handling the steering knuckle, always install the packing inserts into the needle bearings to prevent the rollers from falling out.</p> </div> <div data-bbox="354 421 928 450" data-label="Text"> <p>Install the upper needle bearings as follows:</p> </div> <div data-bbox="411 481 1011 916" data-label="Image"> </div> <div data-bbox="1046 770 1398 898" data-label="Caption"> <p>Figure 25: VH No. sleeve (2): A996350050 VH No. sleeve (3): A996350051 VH No. mandrel: A996170190</p> </div> <div data-bbox="400 981 1417 1514" data-label="List-Group"> <ul style="list-style-type: none"> a) Invert the steering knuckle. b) Remove the packing insert from the upper needle bearings. c) Slide the upper needle bearings onto sleeve (2). d) Locate sleeve (2) together with the upper needle bearings above the steering knuckle bore. e) Install mandrel (4). f) Locate sleeve (3) in the lower yoke of the steering knuckle to act as a pilot for the mandrel. g) By applying pressure to mandrel (4), press the upper needle bearings into the bore until stop. </div>

Continued on next page

6.2

Install the lower needle bearing unit as follows:

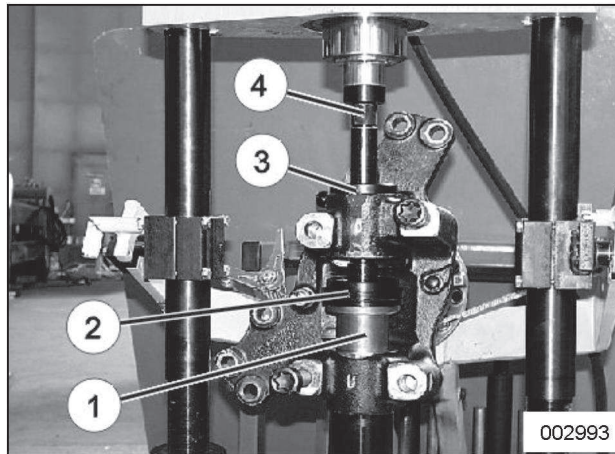

Figure 26:

VH No. sleeve (2): A996350049

VH No. sleeve (3): A996350050

VH No. mandrel: A996170190

- a) Invert the steering knuckle so that its upper yoke is at the top.
- b) Slide the lower needle bearing unit (1) onto sleeve (2). Leave the packing insert in place.
- c) Locate sleeve (2) together with the bearing unit above the steering knuckle bore.
- d) Install mandrel (4).
- e) Locate sleeve (3) in the upper yoke of the steering knuckle to act as a pilot for the mandrel.
- f) By applying pressure to mandrel (4), press the bearing unit into the bore until stop.

6.3

Install the grease seal.

Continued on next page

6.4

Check the axial clearance. Select the appropriate shim washer thickness as follows:

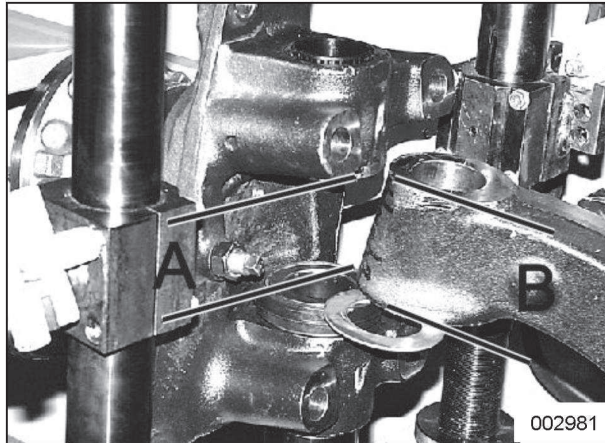

Figure 27

- a) Gauge the internal dimension between the lower needle bearing unit and the upper steering knuckle yoke (measure "A").
- b) Gauge between the machined upper and lower faces of the carrier center (measure "B").
- c) Gauge the thickness of the shim washer (measure "C").
- d) Axial clearance: **$E = A - (B+C)$**

Maximum allowable axial clearance is 0.2 mm (0.008 inch). If necessary, use a thicker shim washer.

6.5

With the ram of the press on top, center steering knuckle (1) between drift (2) and distance sleeve (3). Position the steering knuckle assembly on the carrier center while you slide the proper shim washer between the lower face of the carrier center and the lower needle bearing unit.

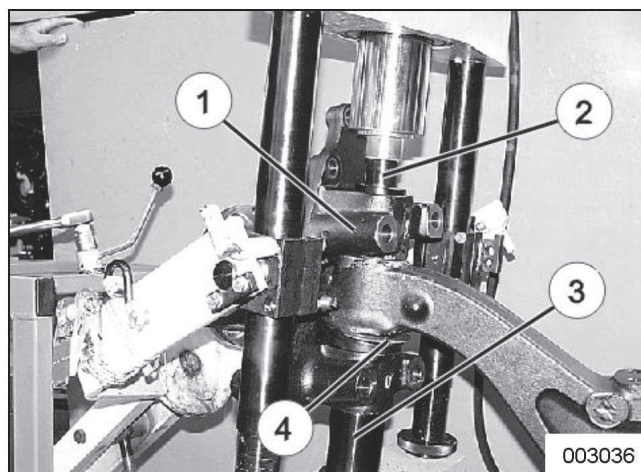

Figure 28:

VH No. drift: A996170179
VH No. sleeve : A996040228

Continued on next page

6.6

Carefully remove the portable press. Secure the steering knuckle with a sling (1) and hoist against falling down. Shift the steering knuckle with one hand and insert guide pin (2) from the top into the king-pin bore with the other hand. Carefully align the steering knuckle and shim washer with the carrier center.

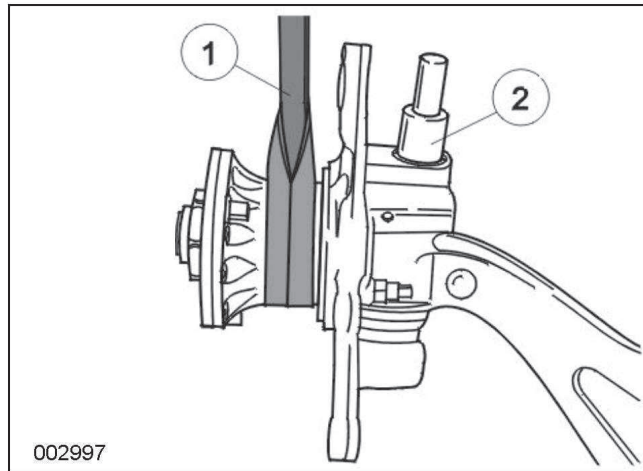

Figure 29:

VH No. guide pin: A996170196

6.7



CAUTION!

The king-pin can only be installed through the top of the steering knuckle. The king-pin must be dry, free of grease and clean.

Position king-pin (1), with the smaller diameter at the bottom, together with magnetic guide (2) into the steering knuckle.

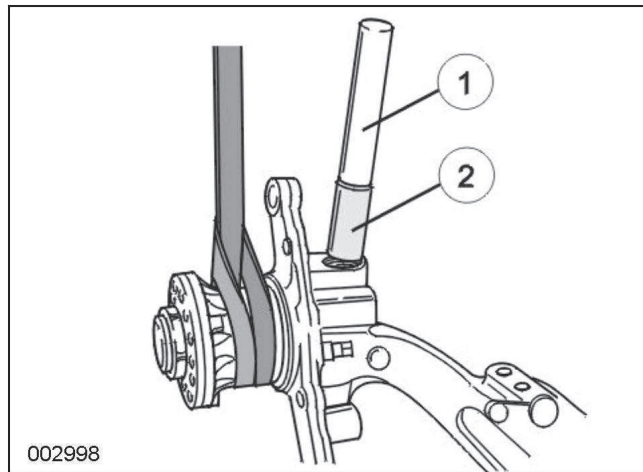

Figure 30:

VH No. guide: A996170197

6.8

Remove the sling and hoist. Roll the press, with the ram on the top, under the steering knuckle.

Continued on next page

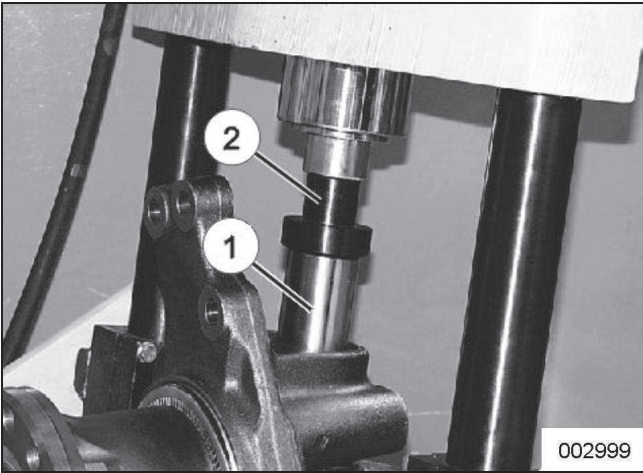
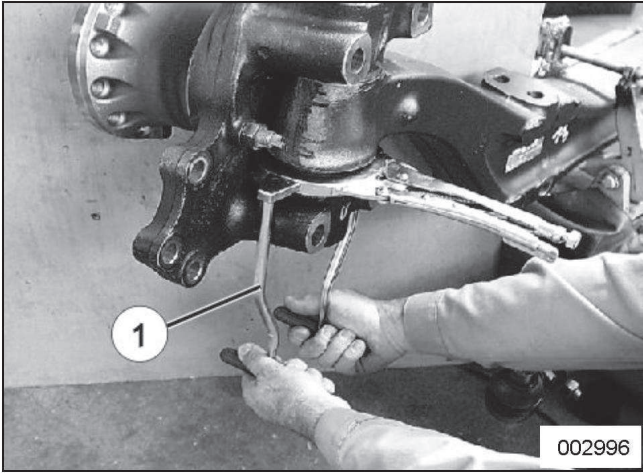
<p>6.9</p>	<p>Position drift (2) on top of king-pin (1). Press in the king-pin until stop.</p>  <p>Figure 31: VH No. drift: A996170179</p>
<p>6.10</p>	<p>Remove the press tool.</p>
<p>6.11</p>	<p>Using special pliers (1), lift the needle bearing dust shield lip until it locks into position.</p>  <p>Figure 32: VH No. pliers: A996256001</p>
<p>6.12</p>	<p>Install plug (2-Figure 24) with O-ring (15-Figure 24) and snap ring (16-Figure 24). LH steering knuckle of a TD925US with steered tag axle only: install instead of plug (2-Figure 24) the angle sensor for the trailing axle steering system with O-ring (15-Figure 24) and snap ring (16-Figure 24) (<i>refer to the appropriate Van Hool Maintenance Manual for angle sensor installation instructions</i>).</p>
<p>6.13</p>	<p>Install plug (10-Figure 24) with O-ring (6-Figure 24) and snap ring (7-Figure 24).</p>
<p>6.14</p>	<p>Using a high-pressure grease gun, lubricate the upper and lower needle roller bearings with FUCHS Renolit LX-OTP 2 grease.</p>

Continued on next page

7. To free suspension arms from steering knuckle carrier:

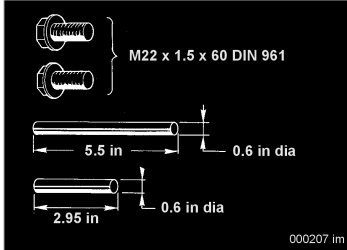
Special tool		Description
VH10695670		Tool set to free suspension arms from steering knuckle carrier
VH11432697		Tool set to pull articulation assembly shaft out of steering knuckle carrier

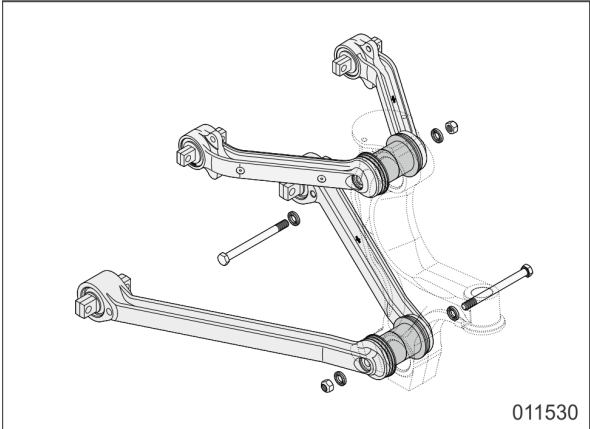
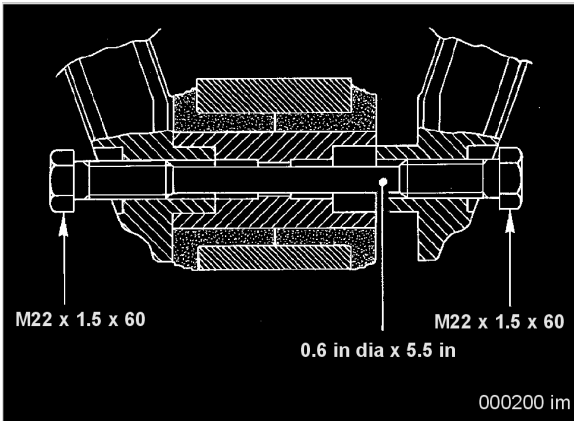
Step	Action
7.1	<p>Remove the articulation assembly bolts.</p>  <p style="text-align: right;">011530 Figure 33</p>
7.2	<p>Separate the first suspension arm from the steering knuckle carrier by using the two M22 screws and the long 0.6 inch dia. pin of tool set 10695670.</p>  <p style="text-align: right;">000200 im Figure 34</p>

Continued on next page

7.3

Separate the second suspension arm from the steering knuckle carrier by using the two M22 screws and the short 0.6 inch dia. pin of tool set 10695670.

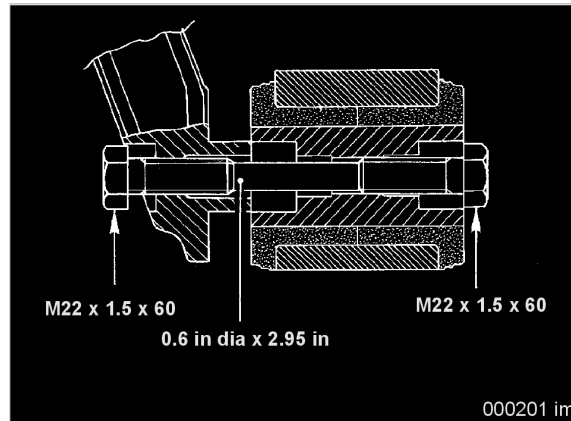

Figure 35

7.4

Repeat step 7.2 and 7.3 for the other suspension arms.

7.5

Pull the articulation assembly shafts out of the rubber bushings by using tool set 11432697.

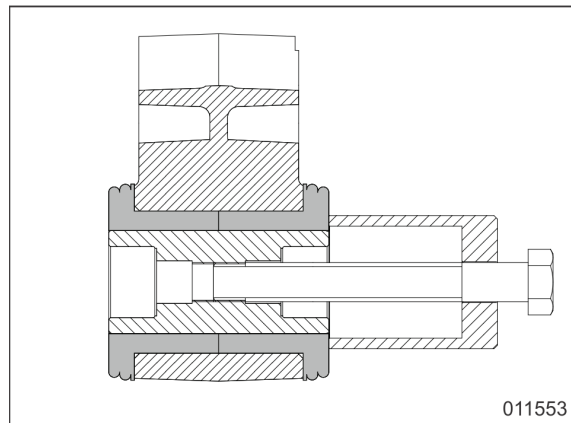

Figure 36

Continued on next page

8. To reprogram the position of the angle sensor to the control unit of the tag axle steering system:

The angle sensor is reprogrammed in three steps:

- with the front wheels in the straight-ahead position (“0” on display)
- with the front wheels fully steered to the left (“LEFT” on display)
- with the front wheels fully steered to the right (“RIGHT” on display)

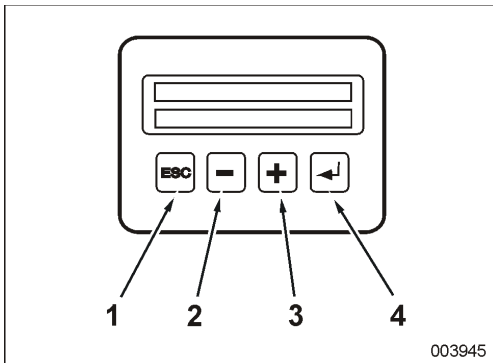
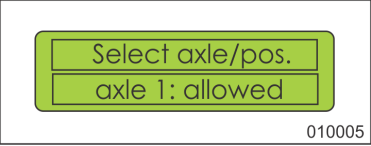
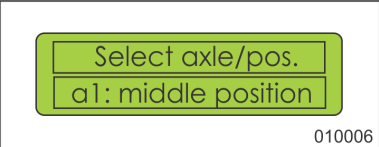
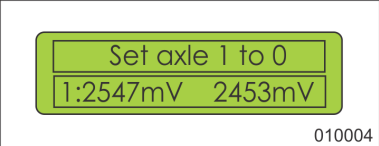
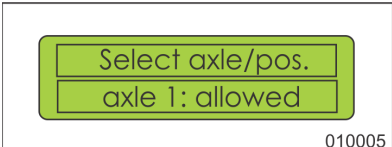
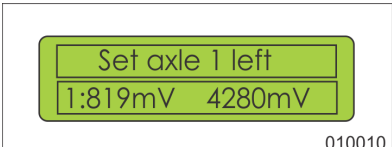

Figure 37: Control panel on control unit of tag axle steering system

Step	Action
8.1	Start the engine.
8.2	Set the front wheels in the straight-ahead position.
8.3	Press key (4) during 3 seconds. On the screen disappears “STANDBY” and appears “OPERATING DATA”.
8.4	Browse with key (2) or (3) through the main menu until on the screen “ACCESS CODE” appears, and confirm with key (4). On the screen appears: <div data-bbox="785 1193 1114 1323" data-label="Image"> </div>
8.5	Enter the numeric code “167”. Enter the first digit with keys (2) and (3), and confirm with key (4). Repeat this for the other digits. On the screen appears: <div data-bbox="785 1429 1114 1559" data-label="Image"> </div>
8.6	Wait a few seconds. The screen automatically returns to the main menu.
8.7	Browse with key (2) or (3) through the main menu until on the screen “ALIGNMENT” appears, and confirm with key (4). On the screen appears: <div data-bbox="785 1724 1123 1854" data-label="Image"> </div>

Continued on next page

<p>8.8</p>	<p>Browse with key (2) or (3) through the menu until on the screen “M3:CALIBRATION BY AXLE + POS” appears, and confirm with key (4). On the screen appears:</p> 
<p>8.9</p>	<p>Browse with key (2) or (3) until on the screen “AXLE 1: ALLOWED” appears, and confirm with key (4). On the screen appears (example):</p> 
<p>8.10</p>	<p>Press key (4) On the screen appears: adjustment phase at the top, current angle sensor output voltages at the bottom (example)</p> 
<p>8.11</p>	<p>Is each of the voltage values between 2350 mV and 2650 mV?</p> <ul style="list-style-type: none"> • If so go to step 8.12. • If not, adjust the mid-position of the angle sensor by repositioning the sensor on its support. Then go to step 8.12.
<p>8.12</p>	<p>Press key (4) to store the values in the memory. On the screen appears:</p> 
<p>8.13</p>	<p>Press key (4). On the screen appears (example):</p> 
<p>8.14</p>	<p>Turn the front wheels completely to the left.</p>
<p>8.15</p>	<p>Is the left voltage value situated between 200 mV and 2100 mV, and the right between 2900 mV and 4800 mV?</p> <ul style="list-style-type: none"> • If so go to step 8.16. • If not, you have to install a new sensor and perform the adjusting procedure again.

Continued on next page

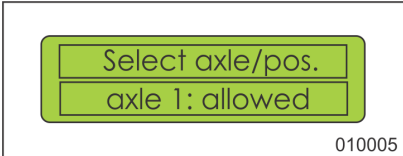
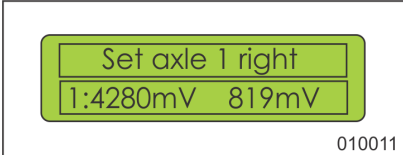
<p>8.16</p>	<p>Press key (4) to store the values in the memory. On the screen appears:</p>  <p>010005</p>
<p>8.17</p>	<p>Press key (4). On the screen appears (example):</p>  <p>010011</p>
<p>8.18</p>	<p>Turn the front wheels completely to the right.</p>
<p>8.19</p>	<p>Is the left voltage value situated between 2900 mV and 4800 mV, and the right between 200 mV and 2100 mV?</p> <ul style="list-style-type: none"> • If so go to step 8.20. • If not, you have to install a new sensor and perform the adjusting procedure again.
<p>8.20</p>	<p>Press key (4) to store the values in the memory.</p>
<p>8.21</p>	<p>Press key (4) three times to close the alignment procedure and exit the adjusting menu.</p>

Continued on next page

WARRANTY:

1. Application:

The recall campaign, subject of this Bulletin is applicable to following units:

Model	VIN
TD925US (non-steered tag axle)	42395, 42465 → 42608, 42616 → 42627
TD925US (with steered tag axle)	42630

2. Terms and conditions:

Van Hool/ABC-Companies will accept warranty claims for this repair as follows:

Parts:

- Parts supply: parts will be supplied through regular channels, free of charge.
- Parts disposal: return affected parts to ABC properly labeled with VIN ID tag.

Labor allowance: hours of labor will be awarded as follows

- Identification: 0.5 (half) hour
- Replacement of one steering knuckle carrier assembly: 18 hours
- Front axle alignment: 2 hours
- Reprogramming of tag axle steering system angle sensor: 10 minutes

Campaign target date: Service Bulletin issue date + 0,5 year

3. Claim references:

- Job code for identification: O06200N
- Job code for replacement: O06200V
- Job code for front axle alignment: D21087R
- Job code for reprogramming of tag axle steering system angle sensor: D21069

Claim submission: If there are any questions regarding this campaign, please call ABC Customer Care & Parts Source toll-free for guidance on 1-877-427-7278. Listen for the prompts for warranty and select that option.

INFORMATION HANDLING:

Important supplements to and modifications of the technical information not yet included in the Van Hool manuals are communicated by means of Service Bulletins.

File the Service Bulletins at the back of your manual, in numerical order.

To make sure that you will be reminded of the Bulletins that have appeared in the meantime while paging the manual, mark the pages concerned by hand with the Service Bulletin number.