



Recall Bulletin



F/CMVSS NONCOMPLIANCE RECALL

SUBJECT: Park Brake Cable Not Connected

MODELS: 2015 Chevrolet Corvette

It is a violation of Federal law for a dealer to deliver a new motor vehicle or any new or used item of motor vehicle equipment (including a tire) covered by this notification under a sale or lease until the defect or noncompliance is remedied.

All involved vehicles that are in dealer inventory must be held and not delivered to customers, dealer traded, or used for demonstration purposes until the repair contained in this bulletin has been performed on the vehicle.

CONDITION

General Motors has decided that certain 2015 model year Chevrolet Corvettes may fail to conform to S7.12 of Federal/Canada Motor Vehicle Standard (FMVSS/CMVSS) 135 (parking brake). Some of these vehicles have been built without one of the rear parking brake cables fully seated and engaged. In this condition, the parking brake will only operate on one of the rear park brake drums leading to a reduction in the parking brake's operational capability. This reduction in operational capability may cause the vehicle to roll away if parked on a steep gradient, which would render a vehicle noncompliant with FMVSS/CMVSS 135 and increase the risk of a crash.

CORRECTION

Dealers are to inspect, and if required, attach one or both of the rear park brake cables.

VEHICLES INVOLVED

All involved vehicles are identified by Vehicle Identification Number on the Investigate Vehicle History screen in GM Global Warranty Management system. Dealership service personnel should always check this site to confirm vehicle involvement prior to beginning any required inspections and/or repairs. It is important to routinely use this tool to verify eligibility because not all similar vehicles may be involved regardless of description or option content.

For dealers with involved vehicles, a listing with involved vehicles containing the complete vehicle identification number, customer name, and address information has been prepared and will be provided to US and Canadian dealers through the GM GlobalConnect Recall Reports, or

sent directly to export dealers. Dealers will not have a report available if they have no involved vehicles currently assigned.

The listing may contain customer names and addresses obtained from Motor Vehicle Registration Records. The use of such motor vehicle registration data for any purpose other than follow-up necessary to complete this recall is a violation of law in several states/provinces/countries. Accordingly, you are urged to limit the use of this report to the follow-up necessary to complete this recall.

PART INFORMATION

No parts are required.

SERVICE PROCEDURE

Note: The park brake cable attachment at a single rear corner drum in hat may NOT be installed properly. If rear wheel spin is detected during the inspection, inspect the park brake cable attachment at the rear corner drum in hat location where the rear wheel spin is detected.

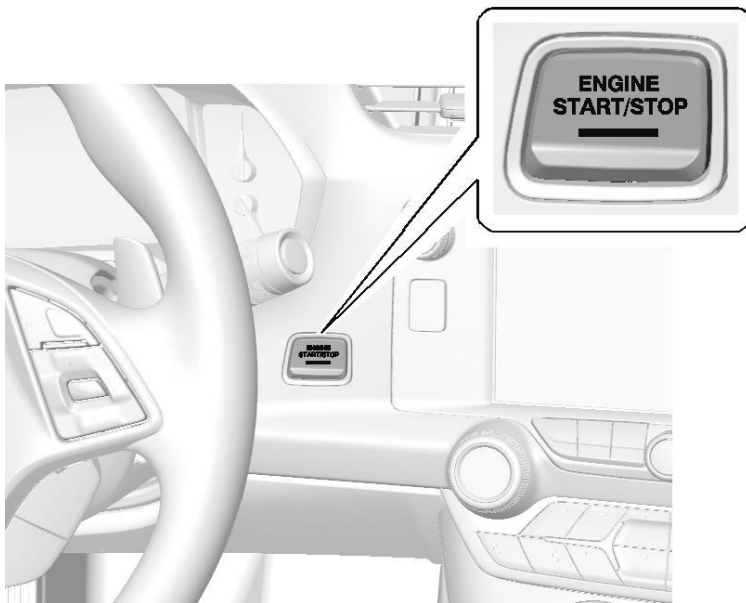

3277694

1. Raise and support the vehicle. Refer to *Lifting and Jacking the Vehicle* in SI. Ensure that you can gain access to the ENGINE START/STOP button and electric parking brake (EPB) button while the vehicle is on a lift. Raise the vehicle enough to ensure the four wheels are not touching the ground.
2. Turn the vehicle to the ON position (green light on, but engine off) by pressing the ENGINE START/STOP button. To obtain the ON position without starting the engine, apply the brake pedal and press the button once to place the ignition system in ON/RUN/START. Release the button BEFORE the engine begins cranking.
3. Place the vehicle in N (Neutral).
4. Apply the electric parking brake (EPB). The EPB switch is on the center console. The red parking brake status light will flash and then stay on once the EPB is fully applied.
5. Attempt to spin the left and right rear wheel.
 - If no wheel spin is detected, the park brake is installed properly on the left and right side of the vehicle. Proceed to step 13.

- If wheel spin is detected, release the EPB and inspect the park brake cable connection to the drum in hat on the wheel that spins. Proceed to step 6.

Note: The park brake cable tension is controlled by the electronic park brake (EPB) module. Tension can be fully released from the park brake cables to allow for service of the park brake system.

6. Perform a parking brake cable adjuster disabling procedure.
 - 6.1 Turn the ignition switch to the ON/RUN position with the engine OFF.
 - 6.2 Place the transmission in PARK (automatic) or NEUTRAL (manual).
 - 6.3 Apply and hold the brake pedal. The brake pedal must remain applied throughout the park brake cable tension release process.
 - 6.4 Press and hold down the electronic park brake (EPB) switch approximately 10 seconds.
 - 6.5 Observe the PARK BRAKE lamp on the instrument cluster.
 - 6.6 When the PARK BRAKE lamp flashes, release then immediately press and release the EPB switch.
 - 6.7 Release the brake pedal. The parking brake cable tension is fully released.

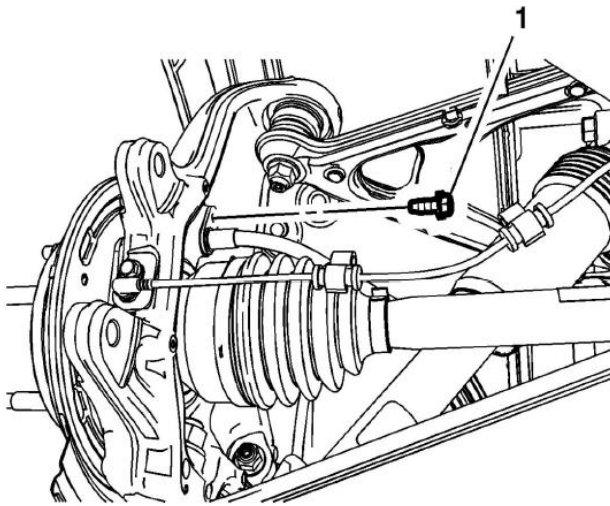

3355581

7. Remove the parking brake rear cable bolt (1) from the rear suspension knuckle.

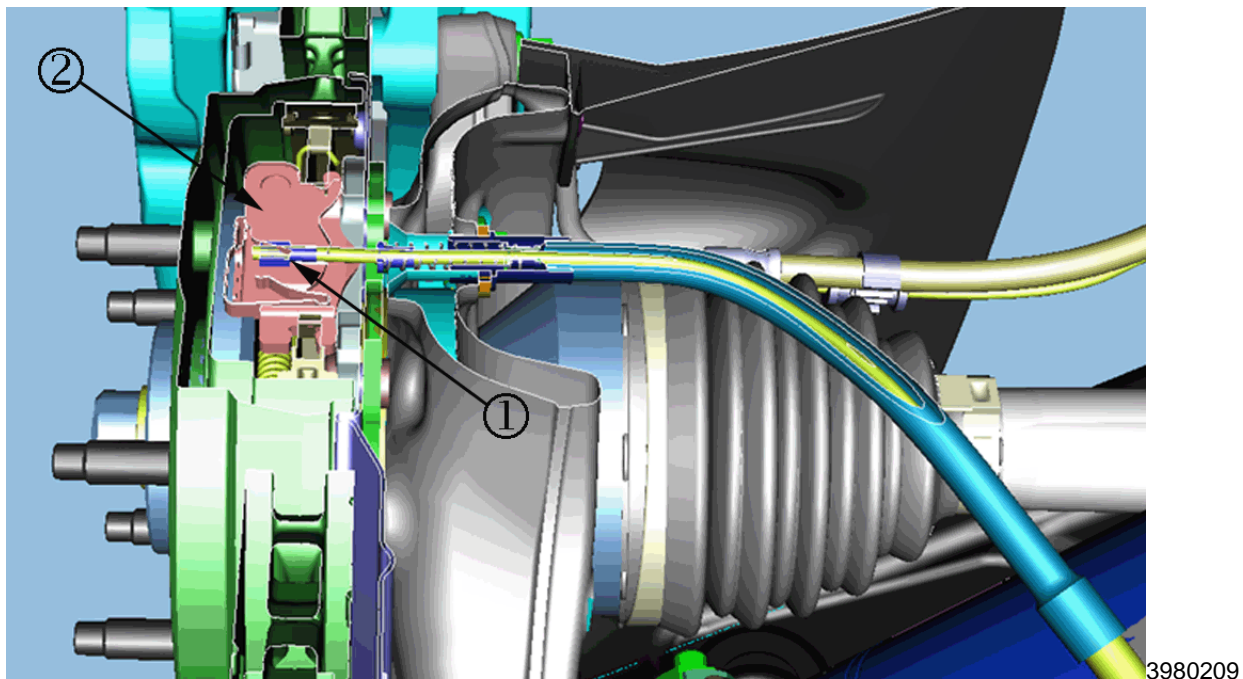

Illustration shown with wheel and brake rotor off of vehicle. Wheel and rotor removal are NOT required to insert the parking cable into the actuator lever.

8. Insert the parking brake rear cable fitting (1) into the actuator lever (2). Angle the cable end rearward into the actuator lever. The cable will snap into the actuator lever. You will hear and feel the cable snap into the actuator lever.
9. Pull on the cable end to ensure the cable is secure in the actuator lever.
10. Install the parking brake rear cable bolt (1) to the rear suspension knuckle and tighten to **9 Nm (80 lb in)**.
11. Apply the EPB. The EPB switch is on the center console. The red parking brake status light will flash and then stay on once the EPB is fully applied.
12. Attempt to spin the rear wheel (s) to ensure the EPB is working properly. If no wheel spin is detected, the park brake is installed properly on the left and right side of the vehicle. Apply and release the park brake 5 times to relearn home position of the EPB. Proceed to step 13.
13. Lower the vehicle. Refer to *Lifting and Jacking the Vehicle* in SI.
14. Place the vehicle in gear and apply the park brake (if manual) or in Park (if automatic).
15. Turn off the vehicle.

COURTESY TRANSPORTATION – For US and Canada

The General Motors Courtesy Transportation program is intended to minimize customer inconvenience when a vehicle requires a repair that is covered by the New Vehicle Limited Warranties. The availability of courtesy transportation to customers whose vehicles are within the warranty coverage period and involved in a product program is very important in maintaining customer satisfaction. Dealers are to ensure that these customers understand that shuttle service or some other form of courtesy transportation is available and will be provided at no charge. Dealers should refer to the General Motors Service Policies and Procedures Manual for Courtesy Transportation guidelines.

WARRANTY TRANSACTION INFORMATION

Submit a transaction using the table below. All transactions should be submitted as a ZFAT transaction type, unless noted otherwise.

Labor Code	Description	Labor Time
9100941	Inspect Electric Parking Brake – No Further Action Required	0.3
9100944	Inspect and Repair Electric Parking Brake --- Left or Right Rear	0.5
9100945	Inspect and Repair Electric Parking Brake --- Both Sides	0.6

CUSTOMER NOTIFICATION – For US and Canada

General Motors will notify customers of this recall on their vehicle.

CUSTOMER NOTIFICATION – For Export

Letters will be sent to known owners of record located within areas covered by the US National Traffic and Motor Vehicle Safety Act.

DEALER RECALL RESPONSIBILITY – For US and Export (US States, Territories, and Possessions)

It is a violation of Federal law for a dealer to deliver a new motor vehicle or any new or used item of motor vehicle equipment (including a tire) covered by this notification under a sale or lease until the defect or noncompliance is remedied.

The US National Traffic and Motor Vehicle Safety Act provides that each vehicle that is subject to a recall of this type must be adequately repaired within a reasonable time after the customer has tendered it for repair. A failure to repair within sixty days after tender of a vehicle is prima facie evidence of failure to repair within a reasonable time. If the condition is not adequately repaired within a reasonable time, the customer may be entitled to an identical or reasonably equivalent vehicle at no charge or to a refund of the purchase price less a reasonable allowance for depreciation. To avoid having to provide these burdensome remedies, every effort must be made to promptly schedule an appointment with each customer and to repair their vehicle as soon as possible. In the recall notification letters, customers are told how to contact the US National Highway Traffic Safety Administration if the recall is not completed within a reasonable time.

This bulletin is notice to you that the new motor vehicles included in this recall may not comply with the standard identified above. Under Title 49, Section 30112 of the United States Code, it is illegal for a dealer to sell a new motor vehicle which the dealer knows does not comply with an applicable Federal Motor Vehicle Safety Standard. As a consequence, if you sell any of these motor vehicles without first performing the recall correction, your facility may be subject to a civil penalty for each such sale.

DEALER RECALL RESPONSIBILITY - All

All unsold new vehicles in dealer's possession and subject to this recall must be held and inspected/repaired per the service procedure of this recall bulletin before customers take possession of these vehicles.

Dealers are to service all vehicles subject to this recall at no charge to customers, regardless of mileage, age of vehicle, or ownership, from this time forward.

Customers who have recently purchased vehicles sold from your vehicle inventory, and for which there is no customer information indicated on the dealer listing, are to be contacted by the dealer. Arrangements are to be made to make the required correction according to the instructions contained in this bulletin

In summary, whenever a vehicle subject to this recall enters your vehicle inventory, or is in your facility for service in the future, you must take the steps necessary to be sure the recall correction has been made before selling or releasing the vehicle.

