

July 31, 2014

ATB 52056 (1407)

Safety Recall: Wrong A-Pillar Trim Is Installed

AFFECTED VEHICLES

| Year | Model | Trim | VIN Range |
|------|-------|------|---|
| 2015 | Fit | ALL | Check the iN VIN status for eligibility |

BACKGROUND

A small number of vehicles had the wrong A-pillar trim installed during assembly, which could cause the A-pillar trim to eject into the cabin if the side curtain airbag deploys in the event of a collision.

CORRECTIVE ACTION

Inspect and, if necessary, replace the left and/or right A-pillar trim.

CUSTOMER NOTIFICATION

Owners of affected vehicles will be sent a notification of this campaign beginning in August 2014.

Do an iN VIN status inquiry to make sure the vehicle is shown as eligible.

Some vehicles affected by this campaign may be in your new or used vehicle inventory. These vehicles must be repaired before they are sold.

Should a dealership sell an unrepaired vehicle that subsequently causes an injury or damage because of the recalled item, the dealership will be solely responsible to the damaged party, and will be required to defend and indemnify American Honda for any resulting claims. To see if a vehicle in inventory is affected by this campaign, do a VIN status inquiry before selling it.

PARTS INFORMATION

| Part Name | Part Number | Quantity |
|--|-----------------|----------|
| Left A-Pillar Trim (comes with upper and lower clips) | 84151-T5R-A01ZA | 1 |
| Right A-Pillar Trim (comes with upper and lower clips) | 84101-T5R-A01ZA | 1 |

NOTE: Parts will be called in for each replaced A-pillar trim under this recall. If any good A-pillar trim is replaced, your dealership may be debited.

CUSTOMER INFORMATION: The information in this bulletin is intended for use only by skilled technicians who have the proper tools, equipment, and training to correctly and safely maintain your vehicle. These procedures should not be attempted by "do-it-yourselfers," and you should not assume this bulletin applies to your vehicle, or that your vehicle has the condition described. To determine whether this information applies, contact an authorized Honda automobile dealer.

WARRANTY CLAIM INFORMATION

| Operation Number | Description | Flat Rate Time | Template ID | Failed Part Number |
|------------------|--|----------------|-------------|--------------------|
| 8575A3 | Inspect the left and right A-pillar trim (on service drive). | 0.2 hour | 14-048A | 84151-T5R-A01ZA |
| A | Replace the left and/or right A-pillar trim | 0.2 hour | 14-048B | |

NOTE: The flat rate for replacing one or both A-pillar trims pays 0.2 hour.

Defect Code: 5YP00

Symptom Code: JF900

Skill Level: Repair Technician

INSPECTION

1. Look for a "SIDE CURTAIN AIRBAG" stamp on the left and right A-pillar trim.
 - If the A-pillar trim has "SIDE CURTAIN AIRBAG" stamped on it, the vehicle is OK. No further action is needed.
 - If the A-pillar trim does not have "SIDE CURTAIN AIRBAG" stamped on it, go to REPAIR PROCEDURE.



REPAIR PROCEDURE

1. Remove the A-pillar lower trim.

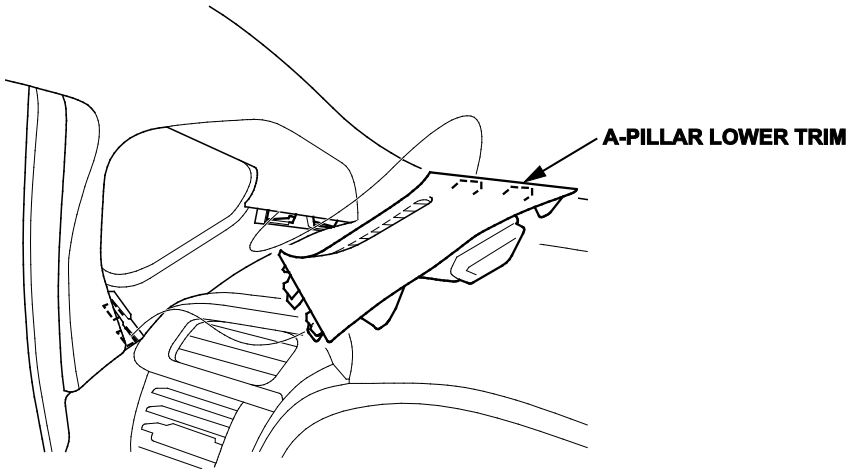

2. Pull out the A-pillar trim.

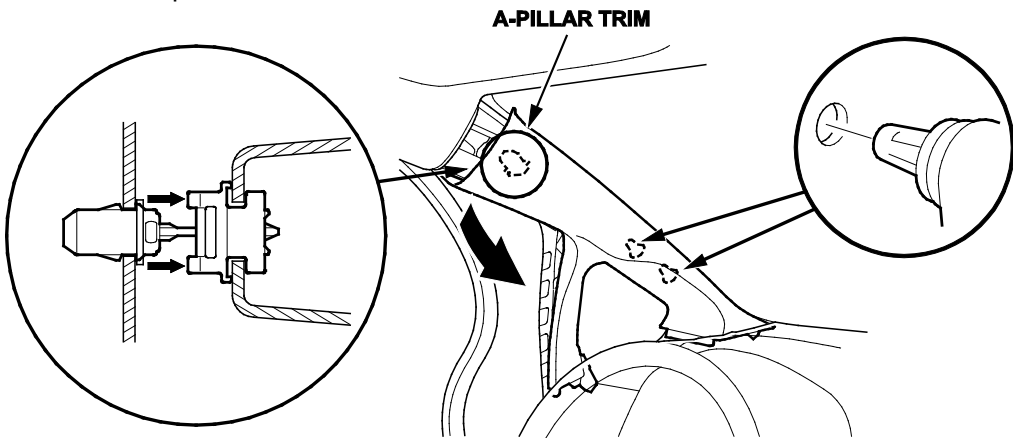

3. Put a shop towel in the opening between the A-pillar and the dashboard to prevent dropping the A-pillar clips.

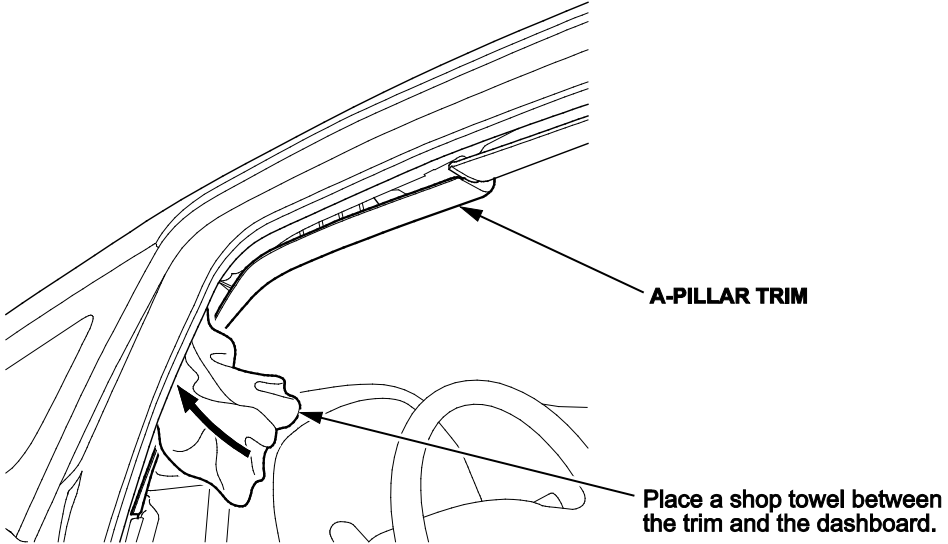

4. Remove the A-pillar trim.

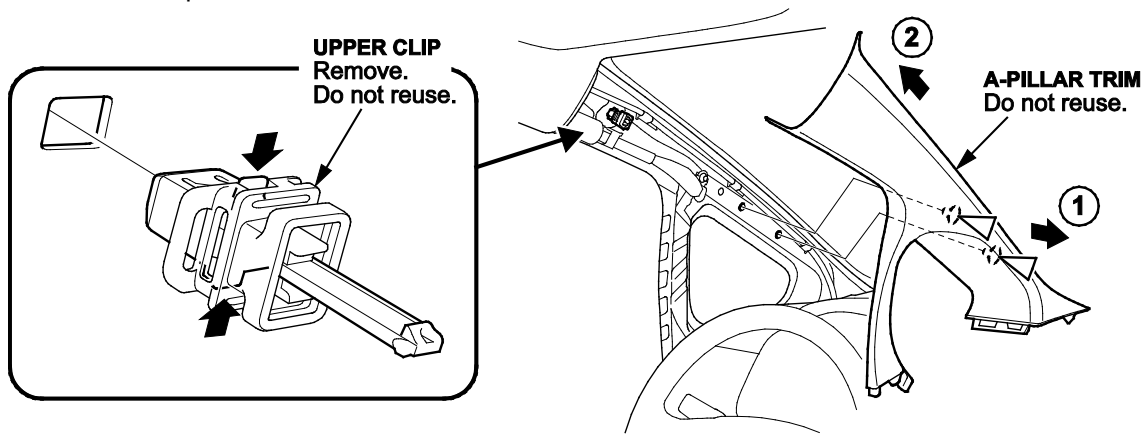

5. Remove the upper clip from the body and discard it.
6. Install the new upper clip into the new A-pillar trim and install the clips.
7. Install the new A-pillar and the lower A-pillar trim.
8. Repeat steps 1 through 7 on the other side if needed.

END