



# SAFETY RECALL BULLETIN

SUBJECT:			No: <b>SR-14-009REV</b>
<b>4B1 ENGINE DRIVE BELT DETACHMENT – SAFETY RECALL CAMPAIGN</b>			DATE: <b>June 2018</b>
			MODEL: <b>See Below</b>
CIRCULATE TO:	<input checked="" type="checkbox"/> GENERAL MANAGER	<input checked="" type="checkbox"/> PARTS MANAGER	<input checked="" type="checkbox"/> TECHNICIAN
<input checked="" type="checkbox"/> SERVICE ADVISOR	<input checked="" type="checkbox"/> SERVICE MANAGER	<input checked="" type="checkbox"/> WARRANTY PROCESSOR	<input checked="" type="checkbox"/> SALES MANAGER

*This bulletin supercedes SR-14-009, issued October 2014, to add a new tensioner and associated flange bolts part numbers for Naturally Aspirated engines. Changes are italicized and indicated by ◀.*

## PURPOSE

The build material of the drive belt equipped on affected vehicles may cause the pulley to wear unevenly, potentially resulting in a detached drive belt. A detached drive belt can lead to battery depletion and an overheated engine. A loss of power steering assist can also occur in vehicles with hydraulic power steering.

This campaign bulletin instructs dealers to replace the drive belt with a countermeasure belt and determine if the idler pulley or auto-tensioner assemblies require replacement.

## AFFECTED VEHICLES

- Certain 2008 – 2011 Lancer built September 26, 2006 – March 30, 2011
- Certain 2008 – 2011 Lancer Evolution and built August 7, 2007 – April 22, 2011
- Certain 2009 – 2011 Lancer/Lancer Sportback Ralliart built November 29, 2007 – April 19, 2011
- Certain 2009 – 2011 Lancer Sportback built September 30, 2008 – December 15, 2010
- Certain 2008 – 2011 Outlander built October 23, 2007 – June 22, 2011
- Certain 2011 Outlander Sport built August 26, 2010 – December 20, 2010

**IMPORTANT**

**Affected new or used inventory vehicles must be repaired before the vehicle is delivered. Dealers must check their inventory vehicles' VINs on the Warranty Super Screen to verify whether the vehicle is involved in this recall campaign. It is a violation of Federal law for a dealer to deliver a new motor vehicle or any new or used item of motor vehicle equipment (including a tire) covered by the notification under a sale or lease until the defect or noncompliance is remedied.**

## CUSTOMER NOTIFICATIONS

A letter will be sent to all owners of affected vehicles requesting them to bring their vehicle to a local Authorized Mitsubishi dealer to have their vehicle remedied. A copy of the customer notification letter appears at the end of this bulletin.

## REQUIRED OPERATIONS

Before starting this campaign procedure, **CHECK THE WARRANTY SUPERSCREEN** to verify if the vehicle is an affected VIN for this campaign and this campaign procedure has not already been completed.

## REPAIR PROCEDURE

1. Place the vehicle on a lift. Shift the selector to "P" (Park) position if applicable, turn the vehicle OFF, and engage the parking brake.
2. Raise the vehicle. Remove the circled undercover(s).
  - a. Lancer and Lancer Sportback (except Ralliart)

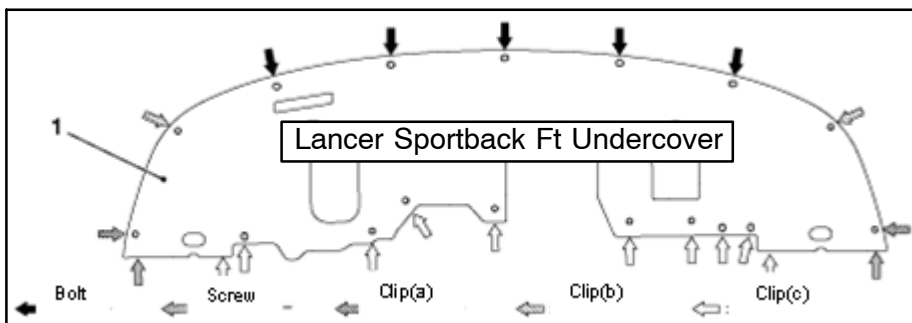
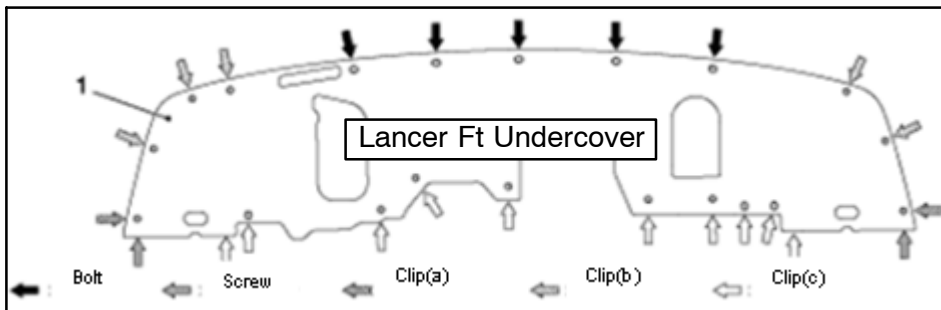
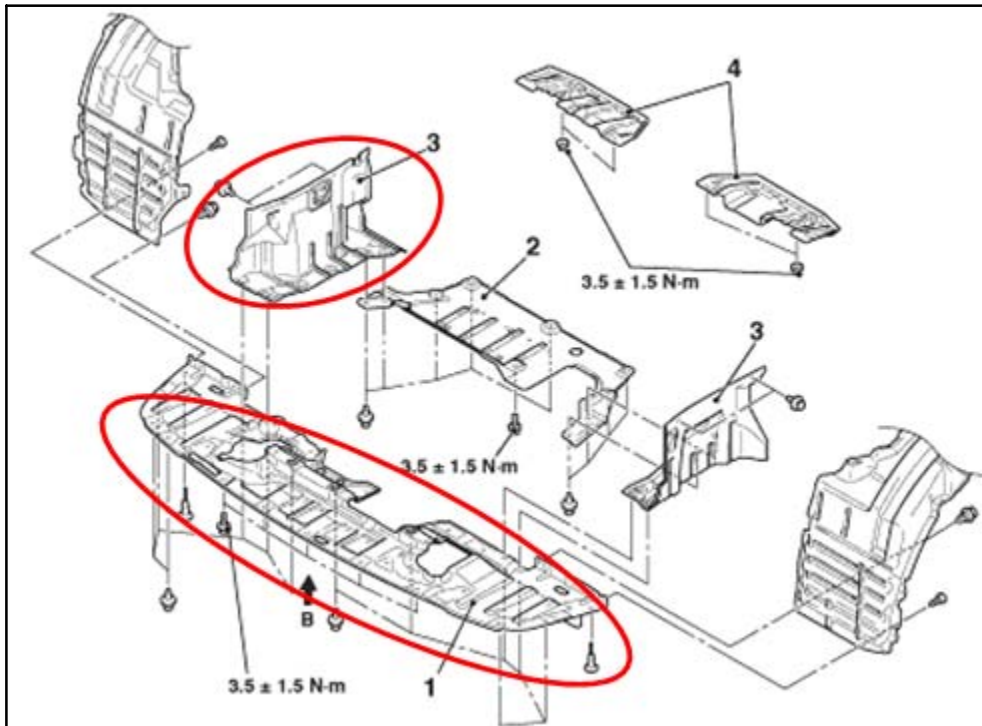

b. Lancer Ralliart and Lancer Sportback Ralliart

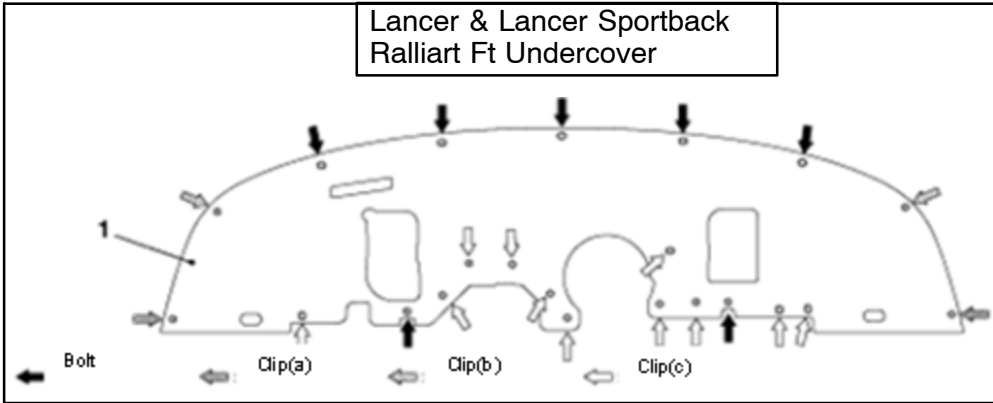
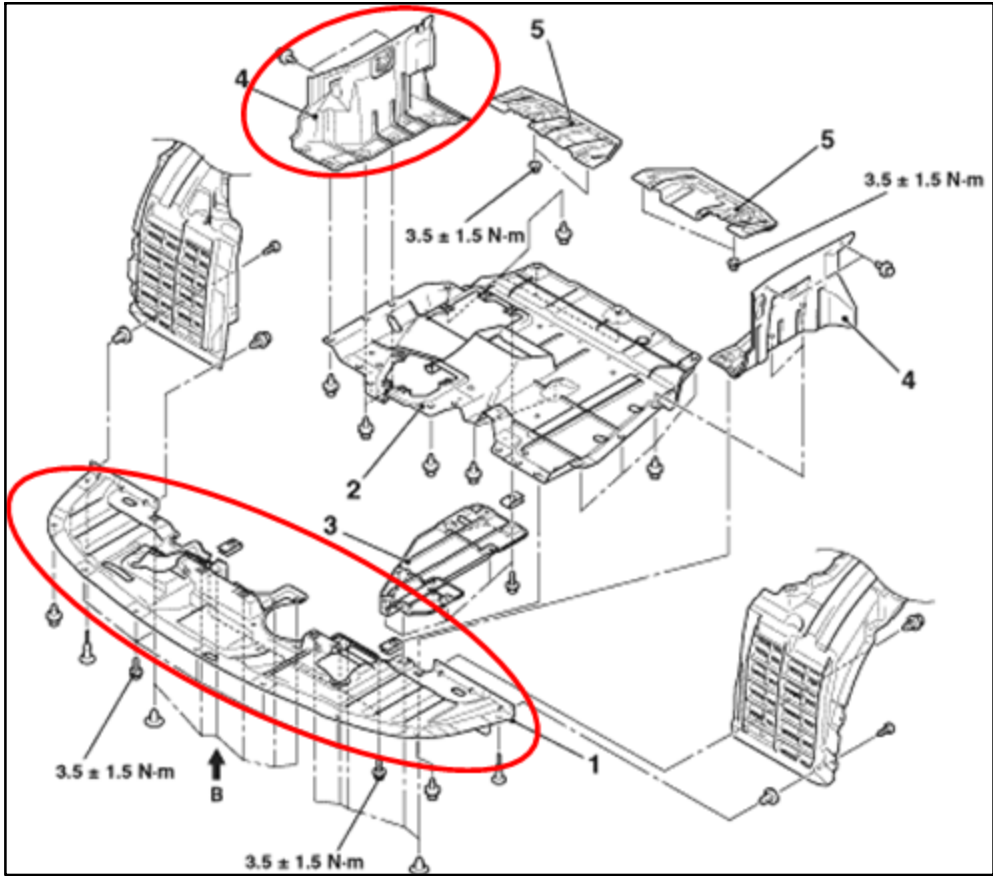

c. Lancer Evolution

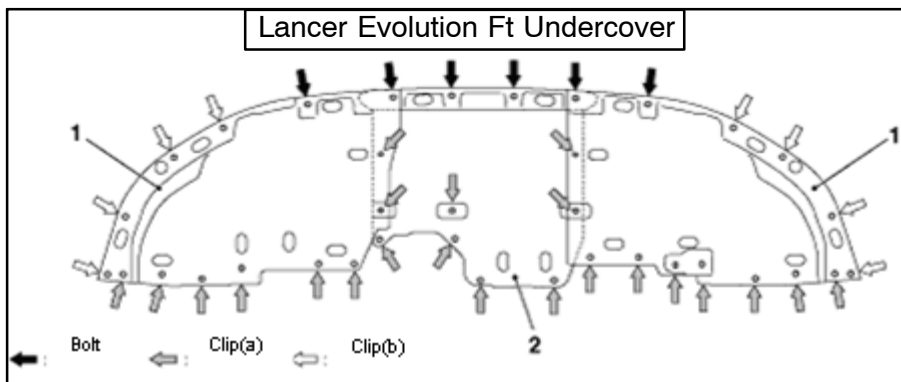
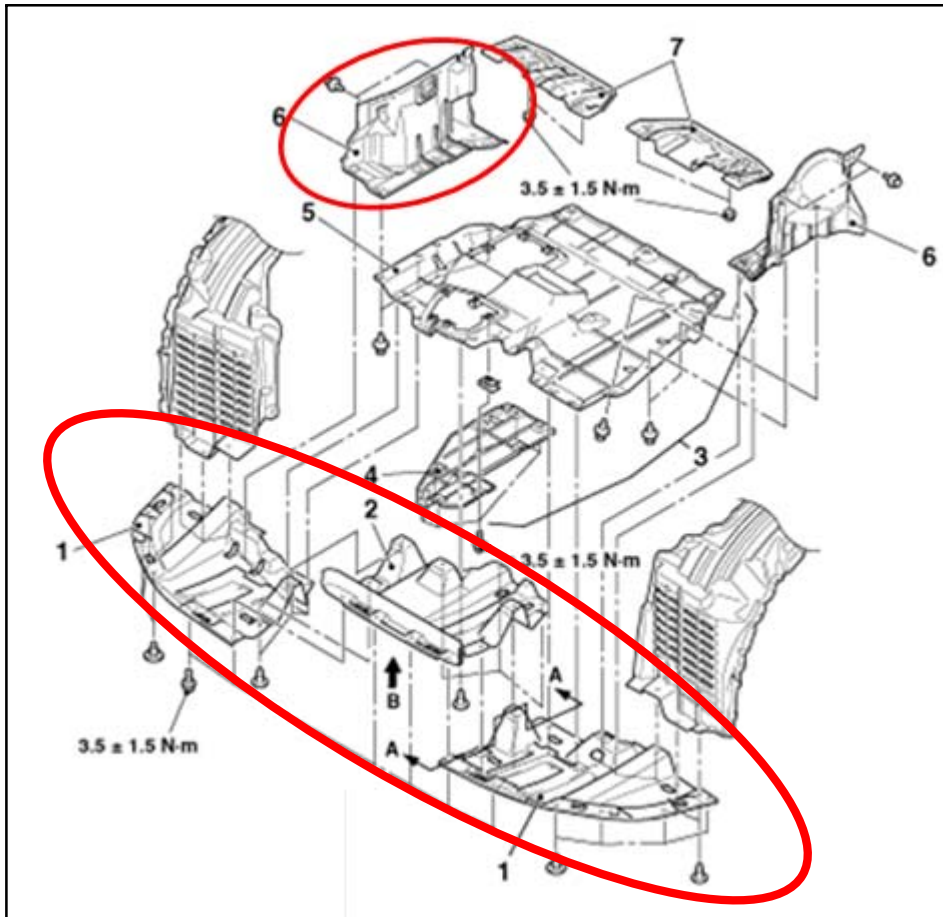

d. Outlander

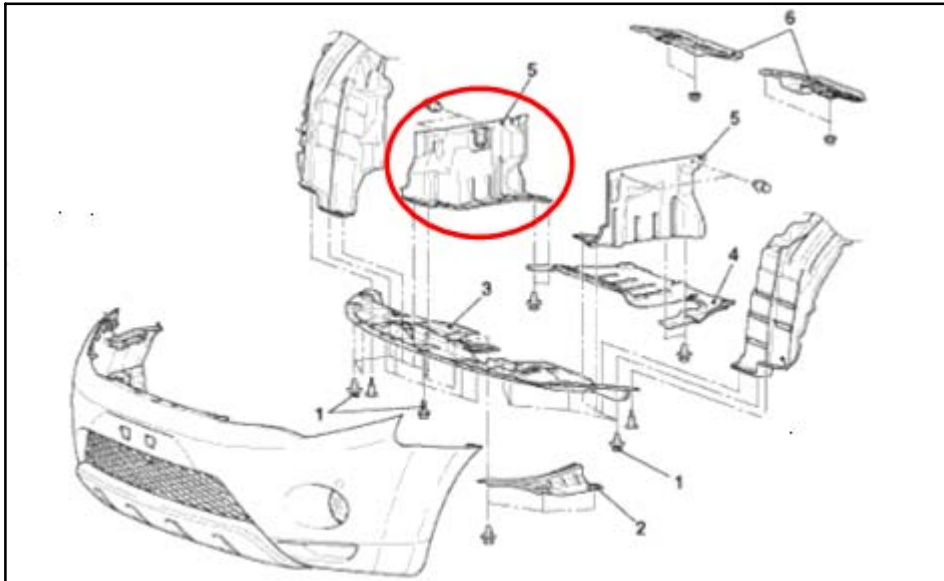

e. Outlander Sport/RVR

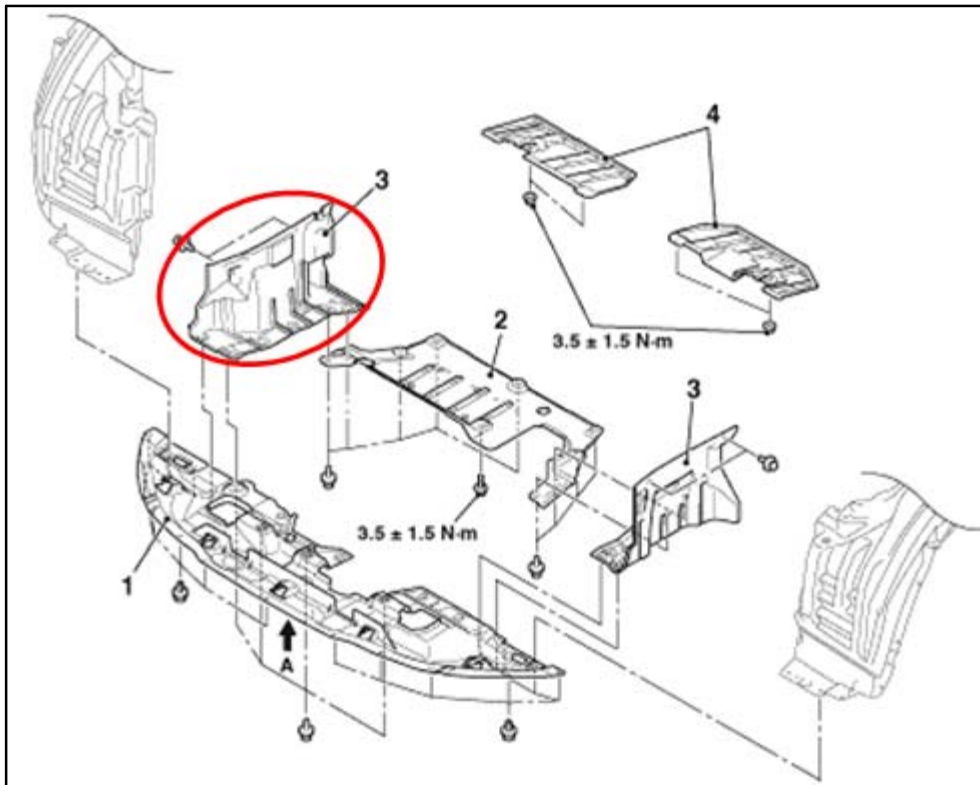

3. Remove the radiator condenser tank:
  - a. For NA vehicles, remove the mounting bolt.
  - b. For TC vehicles, remove it from the mounting bracket.

- From under the vehicle, use a 45° long offset wrench (16mm) to rotate the auto-tensioner pulley bolt counter clockwise to release the tension.

Once the tension is released, insert an L-shaped hexagon wrench into the auto-tensioner hole to lock the auto-tensioner assembly in position.

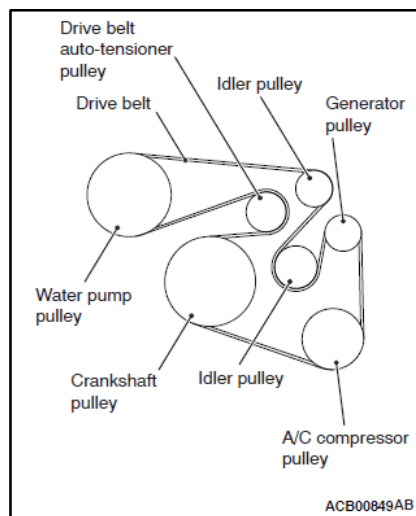
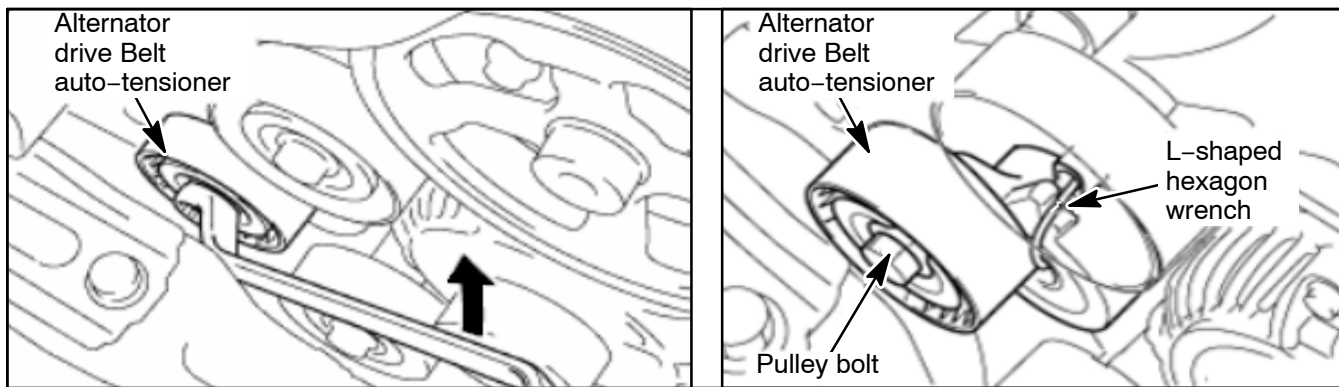

- Remove the drive belt.
- Remove the idler pulley and auto-tensioner assemblies:

**CAUTION** Be careful not to drop any assemblies during removal.



### Naturally Aspirated (NA) Engine

- a. From the engine bay, remove the upper idler pulley.
- b. Apply protective tape around the surface of the auto-tensioner assembly and remove it from the engine bay.

**NOTE:** The auto-tensioner assembly with protective tape applied is shown removed from the vehicle for illustration purposes only.

- c. From underneath the vehicle, remove the lower idler pulley.

### Turbo Charged (TC) Engine

- d. Disconnect the negative battery terminal.
- e. From the engine bay, remove the upper idler pulley.
- f. From underneath the vehicle, remove the lower idler pulley.
- g. Remove the alternator's upper mounting bolt.

Use a felt tip marker and mark an alignment reference point between the alternator and the mounting plate. This will assist you in aligning the two components during reinstallation of the upper mounting bolt.



- h. Loosen the alternator's lower mounting bolt and rotate the alternator towards the front of the vehicle to gain access to the auto-tensioner assembly.

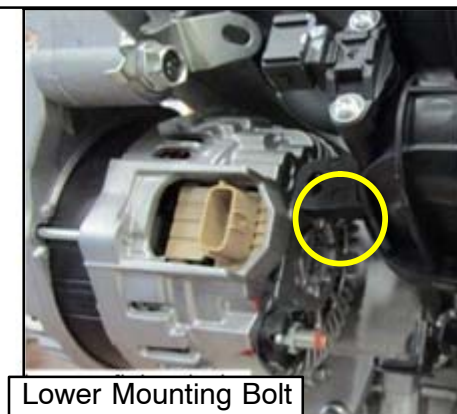
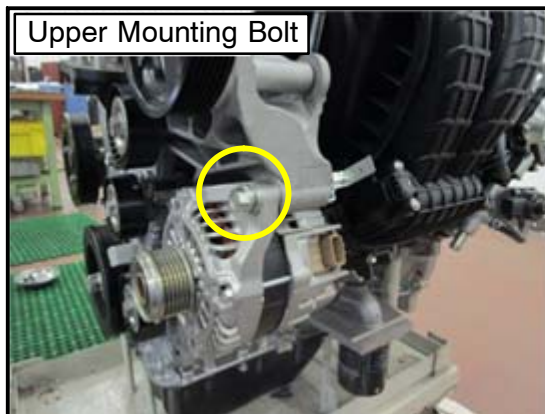

- i. Apply protective tape around the surface of the auto-tensioner assembly and remove it from underneath the vehicle by following Steps 1-4 in the diagram below.

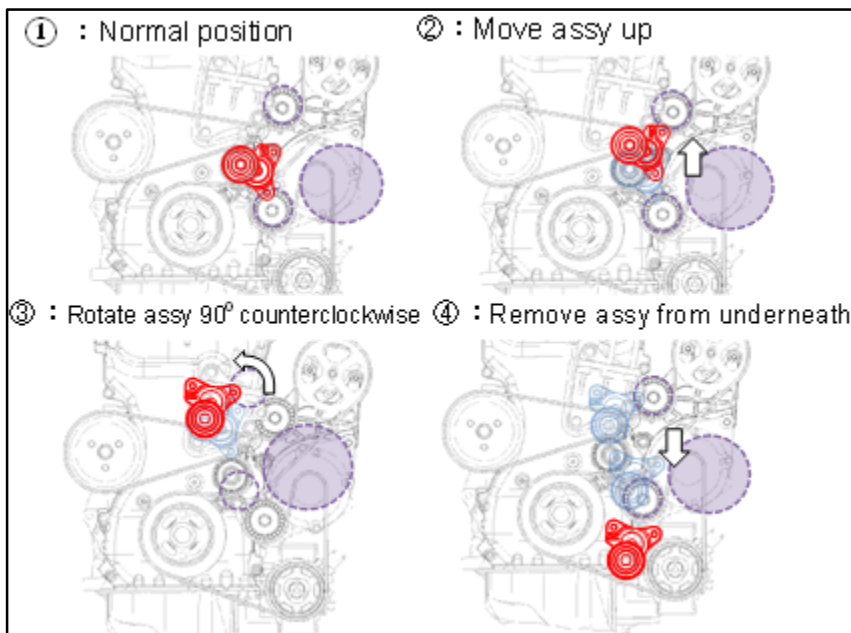

7. Measure the wear on the upper and lower idler pulleys:

- a. Disassemble the upper idler pulley and set it on a surface plate.

**NOTE:** Apply temporary markings (felt tip marker, tape) to distinguish between the upper pulley and lower pulley.

- b. Measure the wear with a vernier caliper.



Before disassembling



Measuring pulley

- (1) Make four measurements to the nearest hundredth decimal (e.g. 69.15mm) every 45° across the top side (Positions 1-4). Repeat on the bottom side (Positions 5-8). Record all eight measurements, determine the minimum and maximum values, and reference the table below.

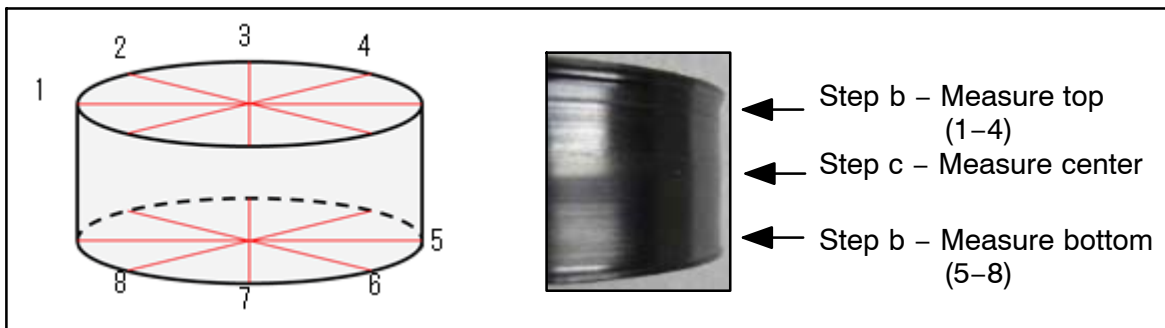

**NOTE:** Avoid measuring ridges when measuring the pulley.

	Position 1	Position 2	Position 3	Position 4	Position 5	Position 6	Position 7	Position 8
<b>Upper Idler Pulley Measurement</b>								

Minimum Value =	Maximum Value =
-----------------	-----------------

If Minimum Value is	And Maximum Value is	Then	Example
Less than 69.70 mm	Anything	Replace idler pulley assembly and proceed to Step 7d	Min = 69.00mm Max = 70.00mm Result = Replace
69.70mm or more	At least 0.20mm greater than minimum value	Replace idler pulley assembly and proceed to Step 7d	Min = 69.70mm Max = 70.00mm Result = Replace
69.70mm or more	0 – 0.19mm greater than minimum value	Set caliper to 0.20mm less than maximum value and proceed to Step 7c	Min = 70.00mm Max = 70.10mm Result = Set caliper to 69.90mm
69.70mm or more	Under 69.90mm	Set Caliper to 69.70mm and proceed to Step 7c	Min = 69.70mm Max = 69.85mm Result = Set caliper to 69.70mm

- c. Place the set vernier caliper around the pulley's center (setting is determined in Step 7b above):
  - (1) If the pulley's center can fit between the caliper's measurements, replace the pulley.
  - (2) If the pulley's center cannot fit between the caliper's measurement, reuse the pulley.
- d. Install the upper idler pulley and torque to  $36 \pm 5$  ft-lb ( $48 \pm 7$  N-m).
- e. Repeat Steps 7a – 7d for the lower idler pulley.

	Position 1	Position 2	Position 3	Position 4	Position 5	Position 6	Position 7	Position 8
<b>Lower Idler Pulley Measurement</b>								

Minimum Value =	Maximum Value =
-----------------	-----------------

8. Remove the protective tape from the auto-tensioner assembly and measure the wear by vernier caliper.

<b>⚠ CAUTION</b> Do not disassemble the auto-tensioner assembly.
--



- a. Make four measurements to the nearest hundredth decimal (e.g. 69.15mm) every 45° across the top side (Positions 1–4) . Repeat on the bottom side (Positions 5–8). Record all eight measurements, determine the min and max values, and reference the appropriate table below (NA or TC).

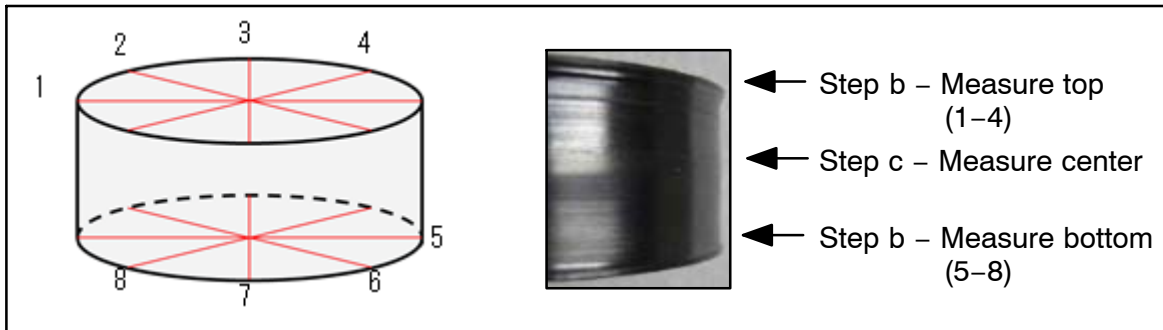

	Position 1	Position 2	Position 3	Position 4	Position 5	Position 6	Position 7	Position 8
<b>Auto-tensioner Assembly Measurement</b>								

Minimum Value =	Maximum Value =
-----------------	-----------------

<b>For NA Engine</b>			
<b>If Minimum Value is</b>	<b>And Maximum Value is</b>	<b>Then</b>	<b>Example</b>
Less than 64.70 mm	Anything	Replace auto-tensioner assembly and proceed to Step 9	Min = 64.50mm Max = 65.00mm Result = Replace
64.70mm or more	At least 0.20mm greater than minimum value	Replace auto-tensioner assembly and proceed to Step 9	Min = 64.70mm Max = 66.85mm Result = Replace
64.70mm or more	0 – 0.19mm greater than minimum value	Set caliper to 0.20mm less than maximum value and proceed to Step 8b	Min = 65.70mm Max = 65.80mm Result = Set caliper to 65.60mm
64.70mm or more	Under 64.90mm	Set Caliper to 64.70mm and proceed to Step 8b	Min = 64.70mm Max = 64.80mm Result = Set caliper to 64.70mm

For TC Engine			
If Minimum Value is	And Maximum Value is	Then	Example
Less than 69.70mm	Anything	Replace auto-tensioner assembly and proceed to Step 9	Min = 69.50mm Max = 71.50mm Result = Replace
69.70mm or more	At least 0.20mm greater than minimum value	Replace auto-tensioner assembly and proceed to Step 9	Min = 69.70mm Max = 72.50mm Result = Replace
69.70mm or more	0 – 0.19mm greater than minimum value	Set caliper to 0.20mm less than maximum value and proceed to Step 8b	Min = 70.00mm Max = 70.10mm Result = Set caliper to 69.90mm
69.70mm or more	Under 69.90mm	Set Caliper to 69.70mm and proceed to Step 8b	Min = 69.70mm Max = 69.80mm Result = Set caliper to 69.70mm

- b. Place the set vernier caliper around the pulley's center (setting is determined in Step 8a above):
- (1) If the pulley's center can fit between the caliper's measurements, replace the auto-tensioner assembly.
  - (2) If the pulley's center cannot fit between the caliper's measurement, reuse the auto-tensioner assembly.

9. Install the auto-tensioner assembly and torque to  $16 \pm 3$  ft-lb ( $22 \pm 4$  N-m).

**NOTE:** You must use new flange bolts (part # MF911363) if auto-tensioner assembly part # 1345A158 is used. The old, unused flange bolts may be discarded.

10. If the vehicle is equipped with a TC engine:

- a. Realign the alternator and reinstall the upper alternator mounting bolt. Torque the upper and lower alternator mounting bolt to  $32 \pm 7$  ft-lb ( $44 \pm 10$  N-m).
- b. Reinstall the negative battery terminal and torque to  $44 \pm 9$  in-lb ( $5 \pm 1$  N-m).

11. Install the new countermeasure drive belt.

 <b>CAUTION</b>	Ensure the drive belt's notched side is mated correctly to the notched pulleys. Ensure the drive belt's flat side is centered on the flat pulleys.
--	---

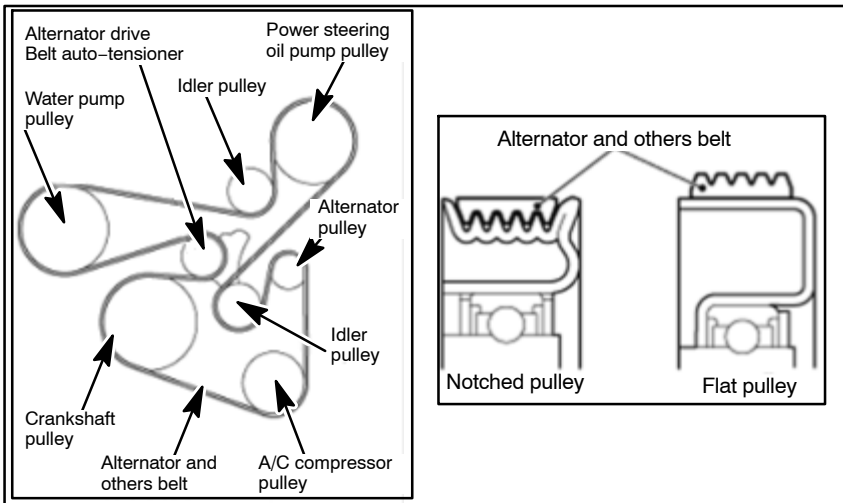

12. Use a 45° long offset wrench (16mm) to rotate the auto-tensioner's pulley bolt counter clockwise to release the tension
13. Remove the L-shaped hexagon wrench inserted in Step 4, or if the auto-tensioner assembly was replaced, remove the pre-installed pin.
14. Apply tension to the drive belt by slowly rotating the auto-tensioner's pulley bolt clockwise. Ensure the auto-tensioner's indicator mark is within the "A" area as shown below.

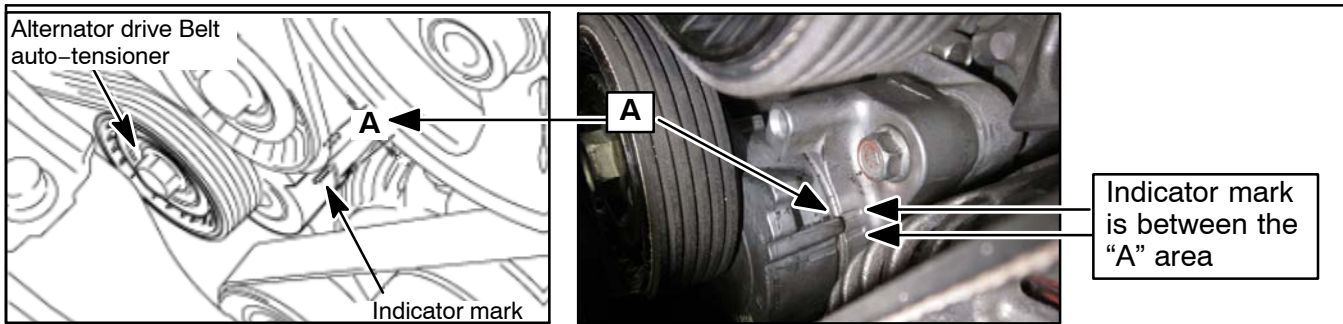

15. Reinstall the radiator condenser tank.
  - a. NA engine – torque to  $9 \pm 1$  ft-lb ( $12 \pm 2$  N-m).
  - b. TC engine – reinsert back into its mounting plate.
16. Reinstall the undercover(s). Torque bolts to  $31 \pm 13$  in-lb ( $3.5 \pm 1.5$  N-m).
17. The repair is now complete. Lower the vehicle and turn the engine ON. Ensure the drive belt operates properly. Return the vehicle to the customer when you have verified the repair is completed satisfactorily. Copy the previously recorded measurements to the measurement summary table located at the end of this bulletin, detach and keep it for your records.

## PARTS INFORMATION

Use the genuine Mitsubishi Part listed below:

Description	Part Number	Qty
Drive Belt (NA Engine w/ Hydraulic Power Steering)	4451A114	1
Drive Belt (NA Engine w/ Electrical Power Steering)	1340A123	1
Drive Belt (TC Engine w/ A/C)	4451A115	1
Auto-Tensioner Assy (NA Engine)	1345A079	1*
<i>or</i>		
Auto-Tensioner Assy (NA Engine)	1345A158	1*
<i>Plus Flange Bolts (only if 1345A158 is used)</i>	MF911363	2*
Auto-Tensioner Assy (TC Engine)	1345A052	1*
Pulley Assy, Idler (NA Engine)	1341A005	2*
Pulley Assy, Idler (TC Engine)	1341A029	2*

\*If Required

## WARRANTY INFORMATION

There are 6 possible repair scenarios plus 6 additional scenarios to cover repairs done at the same time as other recently launched campaigns. Review the scenario selection chart to choose the correct model and operation scenario.

#	Repair Scenarios	Operation Scenario and Labor Time
1	Replace V-Ribbed Belt Only	See Chart
2	Replace V-Ribbed Belt and 1 Pulley	
3	Replace V-Ribbed Belt and 2 Pulleys	
4	Replace V-Ribbed Belt and Tensioner	
5	Replace V-Ribbed Belt, Tensioner and 1 Pulley	
6	Replace V-Ribbed Belt, Tensioner and 2 Pulleys	

#	Repair Scenarios with a .1 hr Reduction Required When Done At Same Time as other Campaigns	Operation Scenario and Labor Time
7	Replace V-Ribbed Belt Only	See Chart
8	Replace V-Ribbed Belt and 1 Pulley	
9	Replace V-Ribbed Belt and 2 Pulleys	
10	Replace V-Ribbed Belt and Tensioner	
11	Replace V-Ribbed Belt, Tensioner and 1 Pulley	
12	Replace V-Ribbed Belt, Tensioner and 2 Pulleys	

**WARRANTY / RECALL CAMPAIGN CLAIM INFORMATION**

Enter all claims as claim type 'C' – Recall/Campaign Claims

Please follow the campaign instructions when entering each claim in order to select the operation code that correctly matches up with the work that was actually performed (next page).

**Campaign Claim Header Section: 4B1 Engine Drive Belt Detachment**

MITSUBISHI DEALER LINK Service Warranty Warranty Claim Help

Claim Entry Vehicle Information PQR/VQR

**Campaign Information**

Campaign Operation No: C1409Z\_\_

Miles/Km: 50000

VIN: JA.....

Service Technician: Emp No:

Spec Value \* Duplicate Recall \*

Dealer: 99320 Ref No: VIN: Claim No: Adj: Claim Status: Incomplete Model and Year:

Save & Continue Main Menu

Enter in the first 6 characters of this campaign labor operation: C1409Z.

This campaign is for the replacement of the drive belt on certain 2008-11 MY Lancer, Lancer Sportback, Lancer Evolution, Lancer Ralliart, Lancer Sportback Ralliart, Outlander Sport (RVR in Canada) and Outlander models. All were MMC models built in Japan.

Check the "Open Recall" area of the Superscreen each time to be certain of a vehicle's eligibility.

Note: There are 214,819 vehicles in the US, Puerto Rico, and Canada involved in this campaign.

This campaign has 12 different repair operation scenarios to select from depending on the vehicle model. Not all scenarios apply to all vehicles. Please study this chart and compare the repair described on the related RO to the scenarios shown. The scenarios for the Outlander and Outlander Sport/RVR require you to select a scenario with a reduced labor time if this campaign was performed at the same time as another campaign announced at the same time (see chart).

When entering the claim, you will need to select the applicable repair scenario from the drop down menu on the MDL claim entry screen. The scenario selected will dictate what parts and labor time are allowed to be claimed.

TSB: SR-14-009		Campaign Number: C1409Z					
Campaign Operations - Select from Claim Drop Down Menu			Labor Times by Model				
Select the repair actually performed and the corresponding operation scenarios and times shown below. Check the repair order to be sure you are selecting the correct repair.							
Repair Descriptions		Operation Scenarios	Lancer, Lancer Sportback	Lancer Evolution, Ralliart & Ralliart			
Replace V-Ribbed Belt Only		C1409Z01	.9 hrs	1.3 hrs			
Replace V-Ribbed Belt and 1 Pulley		C1409Z02					
Replace V-Ribbed Belt and 2 Pulleys		C1409Z03					
Replace V-Ribbed Belt and Tensioner		C1409Z04					
Replace V-Ribbed Belt, Tensioner and 1 Pulley		C1409Z05					
Replace V-Ribbed Belt, Tensioner and 2 Pulleys		C1409Z06					
The repair scenarios apply only Outlander & Outlander Sport/RVR ->			Outlander		Outlander Sport/RVR		
Repair Descriptions		Operation Scenarios	If done alone	If done with SR-14-010	If done alone	If done with SR-14-008	
Replace V-Ribbed Belt Only		C1409Z01	1.0 hrs		.9 hrs		
		C1409Z07		.9 hrs		.8 hrs	
Replace V-Ribbed Belt and 1 Pulley		C1409Z02	1.0 hrs		.9 hrs		
		C1409Z08		.9 hrs		.8 hrs	
Replace V-Ribbed Belt and 2 Pulleys		C1409Z03	1.0 hrs		.9 hrs		
		C1409Z09		.9 hrs		.8 hrs	
Replace V-Ribbed Belt and Tensioner		C1409Z04	1.0 hrs		.9 hrs		
		C1409Z10		.9 hrs		.8 hrs	
Replace V-Ribbed Belt, Tensioner and 1 Pulley		C1409Z05	1.0 hrs		.9 hrs		
		C1409Z11		.9 hrs		.8 hrs	
Replace V-Ribbed Belt, Tensioner and 2 Pulleys		C1409Z06	1.0 hrs		.9 hrs		
		C1409Z12		.9 hrs		.8 hrs	
Repairs to VINS in over-lapping recalls that are performed at the same time where the reduced time was not selected are subject to chargeback							

After entering the required customer data, vehicle information and applicable campaign labor operation number, depending on the "Repair Performed" scenario that is selected from the drop down menu, hitting the "Save and Continue" button will automatically fill-in several fields.

**PARTS:**

Only the parts listed in the TSB are allowed and only those parts associated with the actual repair scenario performed may be claimed.

Description	Part Number	Qty
Drive Belt (NA Engine w/ Hydraulic Power Steering)	4451A114	1
Drive Belt (NA Engine w/ Electrical Power Steering)	1340A123	1
Drive Belt (TC Engine w/ A/C)	4451A115	1
Auto-Tensioner Assy (NA Engine)	1345A079	1*
<i>or</i>		
Auto-Tensioner Assy (NA Engine)	1345A158	1*
<i>Plus Flange Bolts (only if 1345A158 is used)</i>	MF911363	2*
Auto-Tensioner Assy (TC Engine)	1345A052	1*
Pulley Assy, Idler (NA Engine)	1341A005	2*
Pulley Assy, Idler (TC Engine)	1341A029	2*

\*If Required

**LABOR:**

The labor operation and labor time will depend on which one of the 12 repair scenarios was selected. The associated labor time will be automatically filled in based on the scenario selection.

Delete	Sublet	Labor Op	Labor Operation Description	Qty	Hours / Sublet Amt	Total Labor Amt
		C1409Z01	Replace V-Ribbed Belt Only	1	XX	XX.XX
<i>or</i>						
		C1409Z12	Replace V-Ribbed Belt, Tensioner and 2 Pulleys	1	XX	XX.XX

**OTHER CHARGES:**

In rare cases, towing and/or a rental car may be necessary. The lower portion of the labor page has the fields that must be filled in if there are such charges.

Select	Labor Operation	Labor Operation Description	Amount
<input type="checkbox"/>	SHO	SPECIAL HANDLING ORDER	SHO Parts Order
<input type="checkbox"/>	RENTACAR	RENTAL CAR CHARGES	Days Reason <Select one> Rental Company Invoice Number
<input type="checkbox"/>	95300040	FREIGHT CHARGES	Freight Company Invoice Number
<input type="checkbox"/>	95200040	TOWING CHARGES	Towing Company Invoice Number

**REPLACEMENT PARTS AND STORAGE RETENTION:**

**Retain all replaced idler pulley and auto-tensioner assemblies for at least 30 days after the payment of the related campaign claim.** The 30 days begins the day after the claim appears in the "PAID" section of your warranty claim statement. If the part is requested during those 30 days, you must return the subject part(s) as indicated on the parts return request letter. If you do not receive a request after thirty days from the claim payment date, you may scrap the pulley assembly(s).

**MEASUREMENT SUMMARY TABLE**

VIN \_\_\_\_\_

DATE \_\_\_\_\_

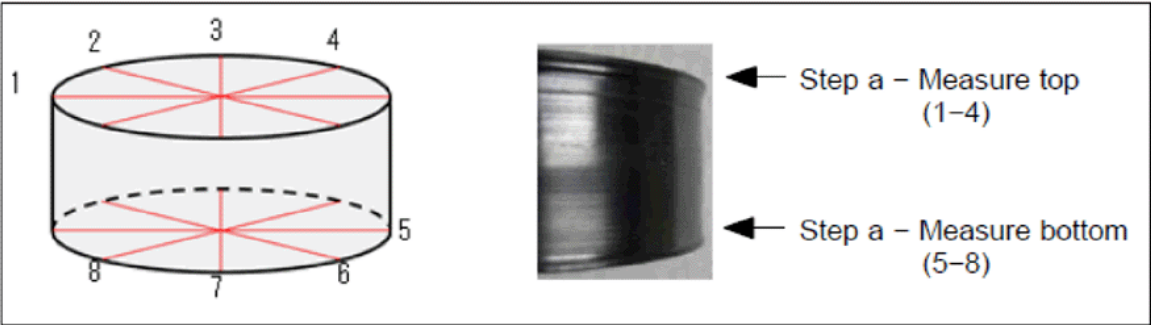

	Position 1	Position 2	Position 3	Position 4	Position 5	Position 6	Position 7	Position 8
Upper Idler Pulley Measurement								

Minimum Value =	Maximum Value =
-----------------	-----------------

	Position 1	Position 2	Position 3	Position 4	Position 5	Position 6	Position 7	Position 8
Lower Idler Pulley Measurement								

Minimum Value =	Maximum Value =
-----------------	-----------------

	Position 1	Position 2	Position 3	Position 4	Position 5	Position 6	Position 7	Position 8
Auto-tensioner Assembly Measurement								

Minimum Value =	Maximum Value =
-----------------	-----------------



## IMPORTANT SAFETY RECALL

**Mitsubishi Motors North America, Inc.**

6400 Katella Avenue  
Cypress, CA 90630  
Telephone: 714-372-6000  
www.mitsubishicars.com

This notice applies to your vehicle, \_\_\_\_\_.

This notice has been sent to you in accordance with the requirements of the National Traffic and Motor Vehicle Safety Act.

Date: October, 2014

Dear Mitsubishi Owner,

**Reason for notice:** Mitsubishi Motors North America, Inc. (MMNA) has decided that a defect which relates to motor vehicle safety exists in certain 2008 - 2011 Lancer, Lancer Evolution, and Outlander vehicles, 2009 - 2011 Lancer Sportback vehicles, and 2011 Outlander Sport vehicles. Due to the build material of the drive belt, the pulleys in the drive belt system can experience unusual wear, resulting in possible detachment of the drive belt.

A detached drive belt could result in battery depletion and an overheated engine, which could cause a moving vehicle to stall and may increase the risk of a crash. A loss of power steering assist could occur in vehicles with hydraulic power steering, resulting in increased steering effort and may also increase the risk of a crash. Engine warning lamp(s) illumination will alert the vehicle operator in the event of drive belt detachment.

**What you should do:** Please contact your local Authorized Mitsubishi Motors dealer and schedule an appointment to have the recall remedy performed on your vehicle. When you bring your vehicle in, please show the dealer this letter. (If you misplace this letter, the dealer will still make this inspection/repair to your vehicle, free of charge.)

**What your dealer will do:** The dealership will replace the drive belt with a countermeasure part, and if necessary, replace the pulley and/or tensioner assemblies with a new part.

**How long will it take?** Depending on the vehicle, the time needed for this remedy is approximately **1.5 hrs.** The dealer may need your vehicle for a longer period of time due to service scheduling issues, but every effort will be made to minimize your inconvenience.

If you experience any problem having your vehicle repaired promptly and/or at no charge, please inform us by calling the Mitsubishi Customer Relations Department at **888-648-7820**. Hours: Monday through Friday 7 a.m. to 4 p.m. (Pacific Time)

If, after contacting Mitsubishi Customer Relations, you still have a problem getting this repair made promptly and/or without charge, write to the Administrator, National Highway Traffic Safety Administration, 1200 New Jersey Avenue SE, Washington, D.C. 20590, or call the toll-free Vehicle Safety Hotline at 1-888-327-4236 (TTY: 1-800-424-9153), or go to <http://www.safercar.gov>.

If you have already encountered a problem with the drive belt, pulley and tensioner assemblies and had them replaced as a result of this specific condition and have paid for the repair, you may send your original repair order or invoice, **and** original receipt/proof of payment to the following address for reimbursement consideration:

Mitsubishi Customer Relations Department, P.O. Box 6400, Cypress, CA 90630-0064

**If you are the lessor of this vehicle**, please forward a copy of this notice to the lessee within ten days to comply with federal regulations.

We appreciate your prompt attention to this matter.

Sincerely,

Mitsubishi Motors North America, Inc.

**C1409Z**