



# Recall Bulletin



## PRODUCT SAFETY RECALL

**SUBJECT: Compressed Natural Gas (CNG) High Pressure Regulator**

**MODELS: 2011-2014 Chevrolet Express and GMC Savana  
Dedicated CNG Vans (RPO LC8&FHZ&UFP&UFM)**

**It is a violation of Federal law for a dealer to deliver a new motor vehicle or any new or used item of motor vehicle equipment (including a tire) covered by this notification under a sale or lease until the defect or noncompliance is remedied.**

**All involved vehicles that are in dealer inventory must be held and not delivered to customers, dealer traded, or used for demonstration purposes until the repair contained in this bulletin has been performed on the vehicle.**

### CONDITION

General Motors has decided that a defect which relates to motor vehicle safety exists in certain 2011-2014 model year Chevrolet Express and GMC Savana dedicated compressed natural gas (CNG) vans (RPO LC8&FHZ&UFP&UFM). Some of these vehicles may have a CNG high pressure regulator that leaks natural gas into the atmosphere. This could cause an explosion or a fire if an ignition source is present.

**If a leak is suspected, the customer should not start the engine or drive the vehicle. The customer should immediately contact their dealer to have the vehicle towed and repaired.**

### CORRECTION

Dealers are to replace the CNG high pressure regulator.

### VEHICLES INVOLVED

All involved vehicles are identified by Vehicle Identification Number on the Investigate Vehicle History screen in GM Global Warranty Management system. Dealership service personnel should always check this site to confirm vehicle involvement prior to beginning any required inspections and/or repairs. It is important to routinely use this tool to verify eligibility because not all similar vehicles may be involved regardless of description or option content.

For dealers with involved vehicles, a listing with involved vehicles containing the complete vehicle identification number, customer name, and address information has been prepared and will be provided to U.S. and Canadian dealers through the GM GlobalConnect Recall Reports. Dealers will not have a report available if they have no involved vehicles currently assigned.

The listing may contain customer names and addresses obtained from Motor Vehicle Registration Records. The use of such motor vehicle registration data for any purpose other than follow-up necessary to complete this recall is a violation of law in several states/provinces/countries. Accordingly, you are urged to limit the use of this report to the follow-up necessary to complete this recall.

### PART INFORMATION

Parts required to complete this recall are to be obtained from General Motors Customer Care and Aftersales (GMCCA). Please refer to your "involved vehicles listing" before ordering parts. Normal orders should be placed on a DRO = Daily Replenishment Order. In an emergency situation, parts should be ordered on a CSO = Customer Special Order.

Part Number	Description	Quantity/Vehicle
19330022	Regulator Kit, CNG High Press	1
Obtain Locally	Parker O-Lube, P/N 884-4 (4 oz. tube), Petroleum Jelly, or Equivalent	As Needed (submit as Net Item)
Obtain Locally	Swagelok Snoop® or equivalent liquid leak detector	As Needed (submit as Net Item)

### SERVICE PROCEDURE

#### Special Tools

J45878 CNG Leak Detector, Robinair TIF8800X CNG Leak Detector or equivalent.

**Note:** Prior to performing this repair, please review GM GlobalConnect Message G\_0000197735 and ensure the vehicle has the new fuel filler door label, glove box hang tag and Owner Manual insert. If any of these items are missing, please follow the instructions provided in the message.

#### CNG High Pressure Regulator Kit

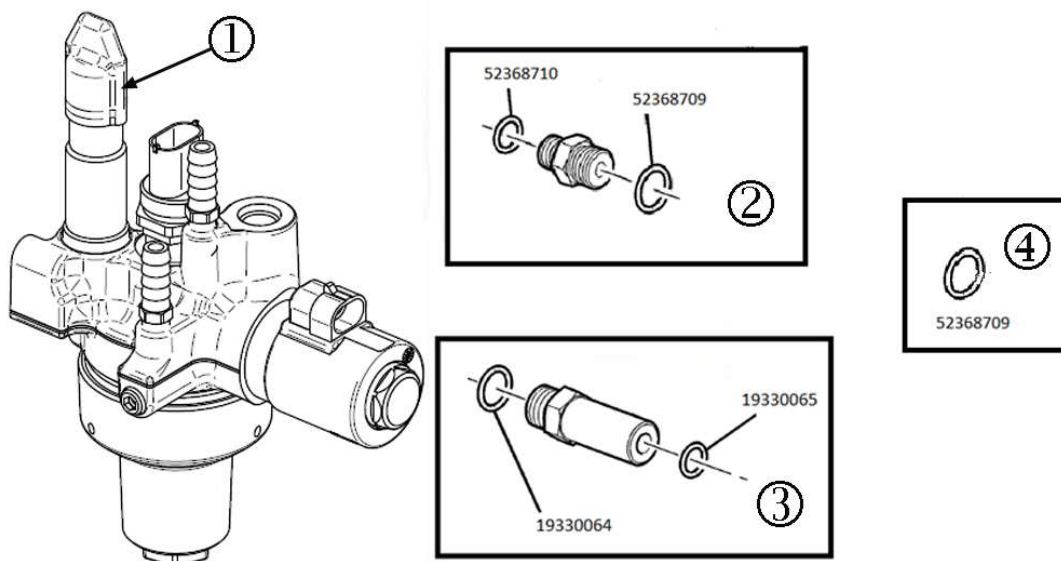

3995239

**Note:** The CNG high pressure regulator kit includes a new regulator, O-ring (4) and two fittings (2) (3) with two O-rings each. Remove and discard the regulator and fittings on the vehicle.

The regulator, O-ring and two fittings included in the kit **MUST** be used to complete the repair in this field action bulletin. The high pressure regulator comes equipped with a vent cap (1) on the pressure relief tube. This cap (1) prevents contaminants from entering the regulator and should **NOT** be removed.

1. Determine if safety recall 13139 has been performed on the vehicle by checking IVH for labor code 9100037.
  - If recall 13139 HAS been performed on the vehicle, proceed to step 2 below to perform this repair.
  - If recall 13139 has NOT yet been performed on the vehicle, perform the repair in bulletin **13139A PRIOR** to performing this repair.
2. Remove the CNG High Pressure Regulator. Refer to *CNG High Pressure Regulator Replacement* in SI.
3. Install the new CNG High Pressure Regulator provided in the parts kit. Refer to *CNG High Pressure Regulator Replacement* in SI.



3996039

4. Record the 10-digit serial number of the new CNG High Pressure Regulator on the vehicle repair order in the comments section. This is important because the serial number must be entered when submitting the warranty transaction. Failure to do so may result in the transaction being debited. Refer to the call-out in the photograph above for the location of the 10-digit serial number.
5. **FOR CALIFORNIA VEHICLES ONLY:** Install a Recall Identification Label and complete a "Proof of Correction" certificate upon recall completion.

#### RECALL IDENTIFICATION LABEL – California Vehicles Only

Place a Recall Identification Label on each vehicle corrected in accordance with the instructions outlined in this Product Recall Bulletin. Each label provides a space to include the recall number and the five-digit dealer code of the dealer performing the recall service. This information may be inserted with a ballpoint pen.

Put the Recall Identification Label on a clean and dry surface of the radiator core support in an area that will be visible to people servicing the vehicle.

When installing the Recall Identification Label, be sure to pull the tab to allow adhesion of the clear protective covering. Additional Recall Identification Labels for US dealers can be obtained from Dealer Support Materials by ordering on the web from DWD Store, [www.gmglobalconnect.com](http://www.gmglobalconnect.com), and then click on the DWD Store link. Request Item Number S-1015 when ordering.



### CUSTOMER REIMBURSEMENT - For U.S.

Customer requests for reimbursement of previously paid repairs for the recall condition are to be submitted to the dealer by October 31, 2015, unless otherwise specified by state law. If this is not convenient for the customer, they may mail the completed Customer Reimbursement Request Form and all required documents to the GM Customer Assistance Center.

**All reasonable and customary costs to correct the condition described in this bulletin should be considered for reimbursement. Any questions or concerns should be reviewed with your GM representative prior to processing the request.**

When a customer requests reimbursement, they must provide the following:

- A completed Customer Reimbursement Request Form. This form is mailed to the customer or can be obtained through GM GlobalConnect.
- The name and address of the person who paid for the repair.
- Paid receipt confirming the amount of the repair expense, a description of the repair, and the person or entity performing the repair.

**IMPORTANT:** GM requires dealers to approve or deny a reimbursement request within 30 days of receipt. If a reimbursement request is approved, the dealer should immediately issue a check to the customer and submit an appropriate warranty transaction for the incurred expense. If a reimbursement request is denied, the dealer MUST provide the customer with a clear and concise explanation, in writing, as to why the request was denied. The bottom portion of the Customer Reimbursement Request Form may be used for this purpose. If the denial was due to missing documents, the customer can resubmit the request when the missing documents are obtained, as long as it is still within the allowed reimbursement period.

Warranty transactions for customer reimbursement of previously paid repairs are to be submitted as required by GM Global Warranty Management. Additional information can also be found in Warranty Administration Bulletin 11-00-89-004.

### CUSTOMER REIMBURSEMENT - For Canada

Customer requests for reimbursement of previously paid repairs to correct the condition described in this bulletin are to be submitted to the dealer prior to or by October 31, 2015.

When a customer requests reimbursement, they **MUST** provide the following:

- Proof of ownership at time of repair.
- Original paid receipt confirming the amount of unreimbursed repair expense(s) (including Service Contract deductibles), a description of the repair, and the person or entity performing the repair.

All reasonable and customary costs to correct the condition described in this bulletin should be considered for reimbursement. Any questions or concerns should be reviewed with your GM representative prior to processing the request.

### COURTESY TRANSPORTATION – For U.S. and Canada

The General Motors Courtesy Transportation program is intended to minimize customer inconvenience when a vehicle requires a repair that is covered by the New Vehicle Limited Warranties. The availability of courtesy transportation to customers whose vehicles are within the warranty coverage period and involved in a product program is very important in maintaining customer satisfaction. Dealers are to ensure that these customers understand that shuttle service or some other form of courtesy transportation is available and will be provided at no charge. Dealers should refer to the General Motors Service Policies and Procedures Manual for Courtesy Transportation guidelines.

### WARRANTY TRANSACTION INFORMATION

Submit a transaction using the table below. All transactions should be submitted as a ZFAT transaction type, unless noted otherwise.

**Note:** To avoid having to "H" route the customer reimbursement transaction for approval, it must be submitted prior to the repair transaction.

Labor Code	Description	Labor Time	Net Item
9100993	Replace CNG High Pressure Regulator *	0.8	**
9100994	Customer Reimbursement Approved	0.2	***
9100995	Customer Reimbursement Denied - For U.S. dealers only	0.1	N/A

**Note:** Customer reimbursement will not close this recall. The service procedure must also be performed on the vehicle.

- \* The serial number of the new CNG high pressure regulator, which was recorded in the comments section on the vehicle repair order, must be entered when submitting the warranty transaction. Failure to do so may result in the transaction being debited.
- \*\* The amount identified in "Net Item" should represent the sum total of the lube and leak detector needed to perform the required repairs, not to exceed \$2.00 USD, \$2.30 CAD, plus applicable Mark-Up.
- \*\*\* The amount identified in "Net Item" should represent the dollar amount reimbursed to the customer.

### CUSTOMER NOTIFICATION – For U.S. and Canada

General Motors will notify customers of this recall on their vehicle.

### DEALER RECALL RESPONSIBILITY – For U.S. States, Territories, and Possessions

It is a violation of Federal law for a dealer to deliver a new motor vehicle or any new or used item of motor vehicle equipment (including a tire) covered by this notification under a sale or lease until the defect or noncompliance is remedied.

The U.S. National Traffic and Motor Vehicle Safety Act provides that each vehicle that is subject to a recall of this type must be adequately repaired within a reasonable time after the customer

has tendered it for repair. A failure to repair within sixty days after tender of a vehicle is prima facie evidence of failure to repair within a reasonable time. If the condition is not adequately repaired within a reasonable time, the customer may be entitled to an identical or reasonably equivalent vehicle at no charge or to a refund of the purchase price less a reasonable allowance for depreciation. To avoid having to provide these burdensome remedies, every effort must be made to promptly schedule an appointment with each customer and to repair their vehicle as soon as possible. In the recall notification letters, customers are told how to contact the U.S. National Highway Traffic Safety Administration if the recall is not completed within a reasonable time.

### DEALER RECALL RESPONSIBILITY – All

All unsold new vehicles in dealers' possession and subject to this recall must be held and inspected/repaired per the service procedure of this recall bulletin before customers take possession of these vehicles.

Dealers are to service all vehicles subject to this recall at no charge to customers, regardless of mileage, age of vehicle, or ownership, from this time forward.

Customers who have recently purchased vehicles sold from your vehicle inventory, and for which there is no customer information indicated on the dealer listing, are to be contacted by the dealer.

Arrangements are to be made to make the required correction according to the instructions contained in this bulletin. Recall follow-up cards should not be used for this purpose, since the customer may not as yet have received the notification letter.

In summary, whenever a vehicle subject to this recall enters your vehicle inventory, or is in your dealership for service in the future, you must take the steps necessary to be sure the recall correction has been made before selling or releasing the vehicle.

