

SUBJECT: Safety Recall Campaign “VG”;
Evaporative Emissions Canister Air Vent Line Replacement

MODEL(S): Kizashi (A6B424)

YEAR: All 2010-2012 and certain 2013

PRODUCTION: October 13, 2009 through July 05, 2012

CONDITION: The vehicle’s evaporative emissions canister’s air vent line becomes restricted. If this occurs, air flow through the evaporative emissions system may be impacted in that excessive negative pressure is created in the fuel tank. This can cause deformation of the fuel tank, which can lead to fuel tank cracks. If the fuel tank becomes cracked, fuel leakage and venting of fuel vapors can occur, increasing the risk of a fire.

CAUSE: Suzuki Motor Corporation has determined that all 2010-2012 and certain 2013 Suzuki Kizashi vehicles were manufactured with an evaporative emissions canister air vent line that is not sufficiently protected. Reported restrictions have been a result of spiders that have entered the evaporative emissions canister air vent line and weaved webs.

CORRECTION: Authorized Suzuki Service Providers will replace the evaporative emissions canister air vent line on affected vehicles with a vent line that has a filter on the end. If the canister vent line is found to be obstructed, the fuel tank will also be replaced.

Affected Departments:

The following departments in your dealership should be notified of this information:

Management Service Warranty Sales Parts Accessories

Suzuki bulletins are intended for use by professional technicians, NOT a “do-it-yourselfer.” They are written to inform these technicians of conditions that may occur on some vehicles, or to provide information that could assist in the proper service of a vehicle. Properly trained technicians have the equipment, tools, safety instructions, and know-how to do a job properly and safely. If a condition is described, DO NOT assume that the bulletin applies to your vehicle, or that your vehicle will have that condition. See your authorized Suzuki Service Provider for information on whether your vehicle may benefit from the information. Suzuki reserves the right to change technical specifications at any time without prior notice.



Repair Kit Contents

PART(S) INFORMATION			
Description	Year	Part Number	Qty.
Pipe Set, Suct	All	18500-50830-RX0	1

WARRANTY INFORMATION				
Campaign Code	Operation Code	Complaint Code	Defect Code	Labor Time
Please refer to the Service Campaign Bulletin SC-70 for claim submission instructions and labor times.				

Work Flow

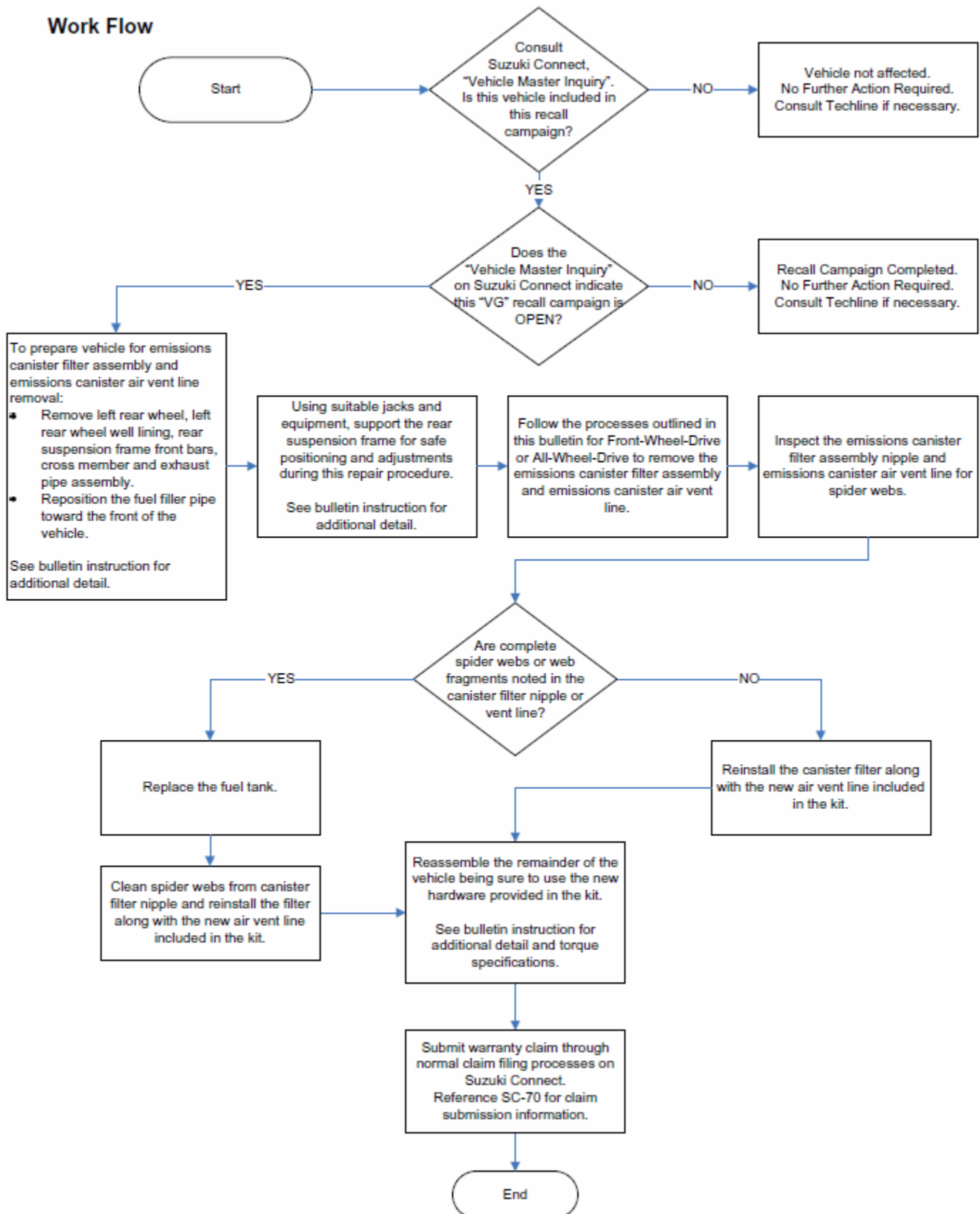

Removal Procedure

1. Hoist the vehicle and remove the left rear wheel.
2. Remove the left rear fender well lining.

NOTE:

The rear fender lining is fixed with three types of clips. Remove the clips as indicated.

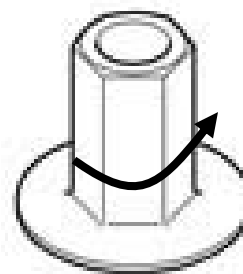
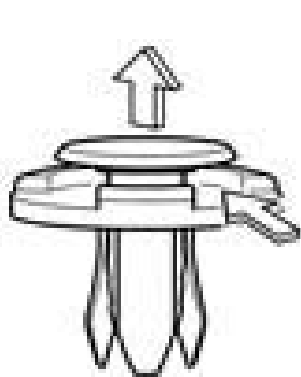

3. Remove the 2 fuel filler bolts.
4. Remove the fuel filler cap and insert a clean dry shop towel suitable to prevent debris from entering the fuel tank.



5. Remove the fuel tank filler neck bolt at the wheel well.



6. Remove the emission canister air vent line from its 2 clamps.



7. Slide the filler neck toward the front of the vehicle.



8. While the filler neck is positioned toward the front of the vehicle, move the emissions canister air vent line out from behind and away from the fuel filler neck.



9. Remove the cross-member from the vehicle.
- Remove 2 bolts and 2 clips of the underbody panels that cover the 4 cross-member bolts.
 - Remove the 4 cross-member bolts (2 each side) and remove the cross-member from the vehicle.

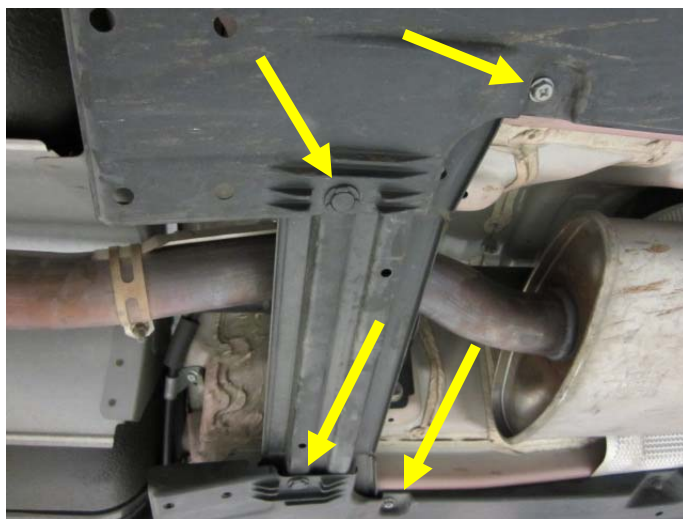
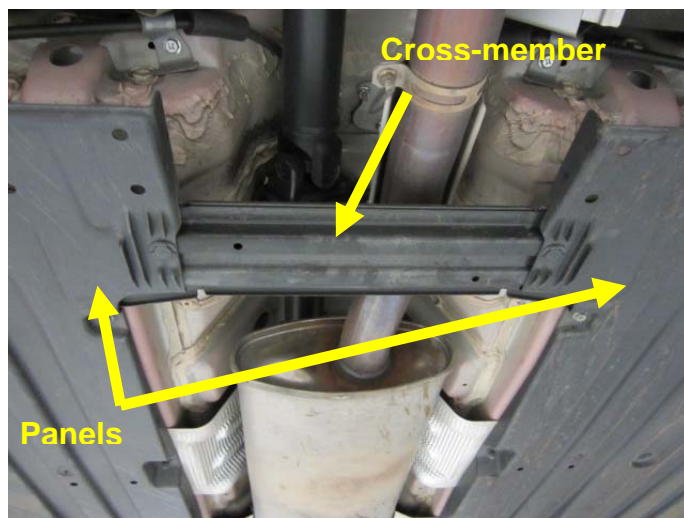

10. Remove the exhaust pipe assembly from the vehicle at "A" and "B".

▲ CAUTION

Working on the vehicle while the exhaust system is still hot can cause a burn.

Ensure that the exhaust system is cool before beginning work.

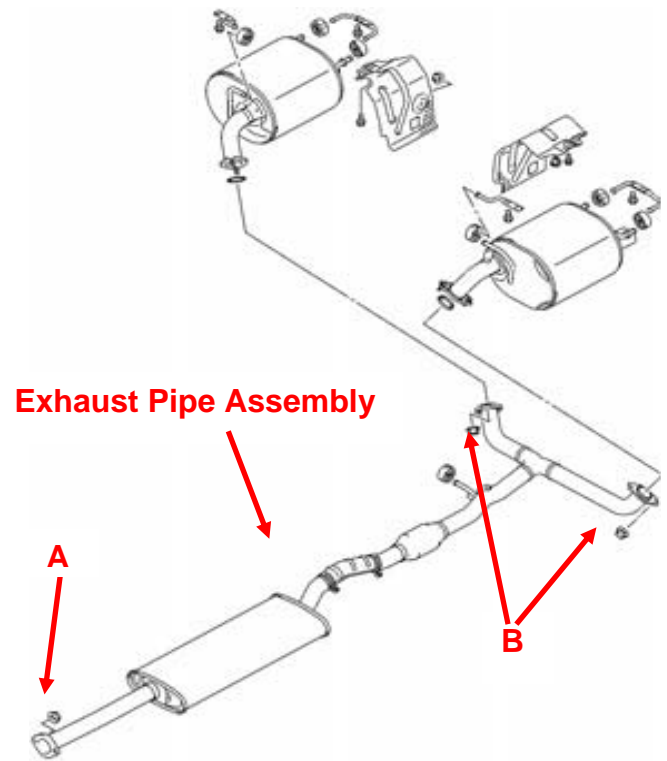

Step #11 is for front-wheel-drive models only.
For all-wheel-drive models skip this step and go to step 13.

11. Support the rear suspension frame with a transmission jack at supporting points "A" and "B".

12. For front-wheel-drive models go to step 14.
For All-wheel-drive models go to step 13.

NOTE:

Because the height is different between the front and rear supporting points of the rear suspension frame, adjust the height using pieces of wood "C" or similar.

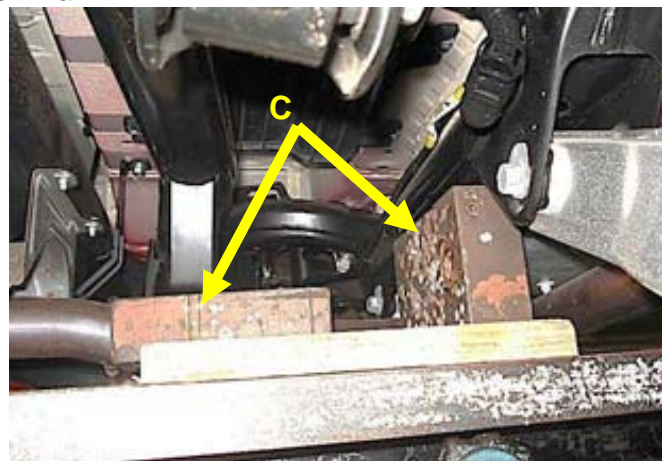
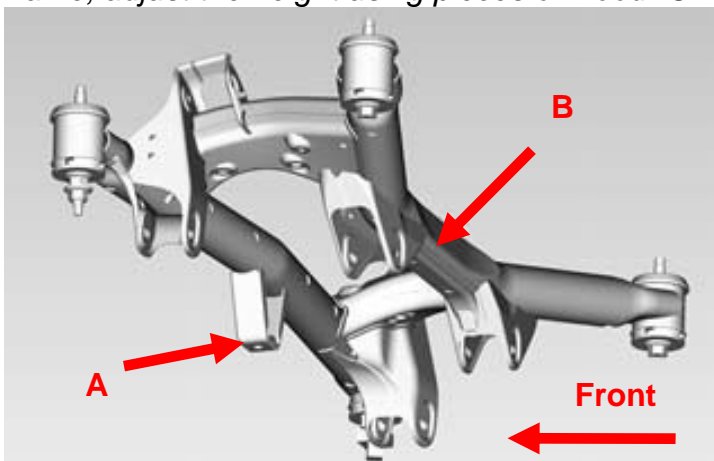

Step #13 is for all-wheel-drive models only.

13. Support the rear differential mount "A" at the rear side of the suspension frame with a transmission jack.

NOTE:

Because the rear differential mount is at a higher position than the rear differential, it is required to use a piece of wood "B" or similar to make the support.

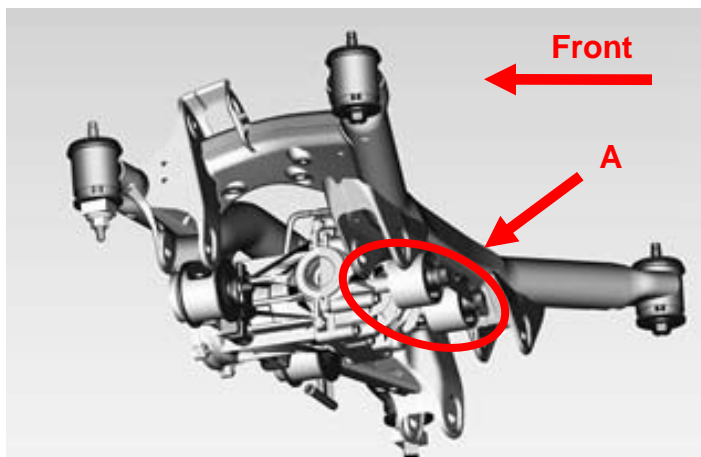

14. Remove the bolts "A" and the nuts "B" to remove the front frame bars "C".

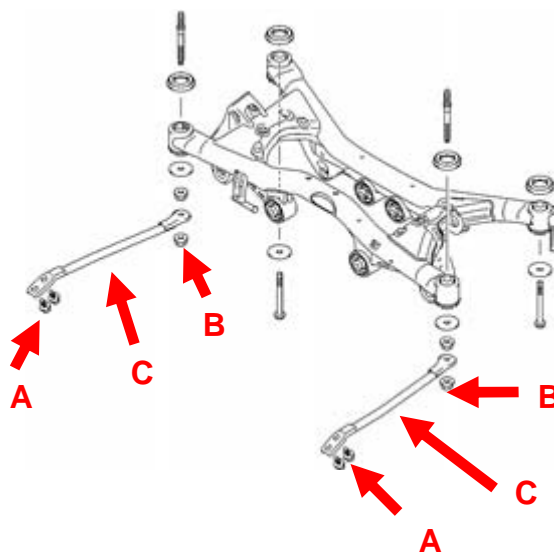

15. Loosen the rear suspension frame front nuts "A". Do Not remove the nuts from the stud bolts "B".

▲ CAUTION

If the rear suspension frame front nuts are completely pulled off of the stud bolt, the rear suspension frame may slip out of the transmission jack which may result in personal injury or damage to vehicle parts.

Do not remove the rear suspension frame front nuts completely until the replacement of the canister air vent line is completed and the rear suspension frame is about to be installed.

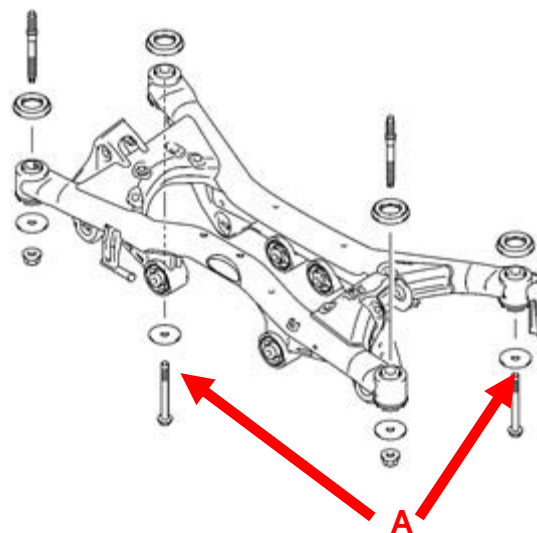
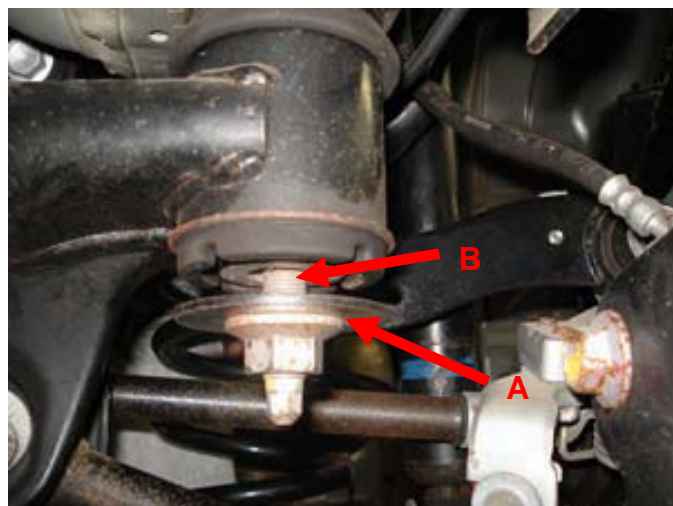
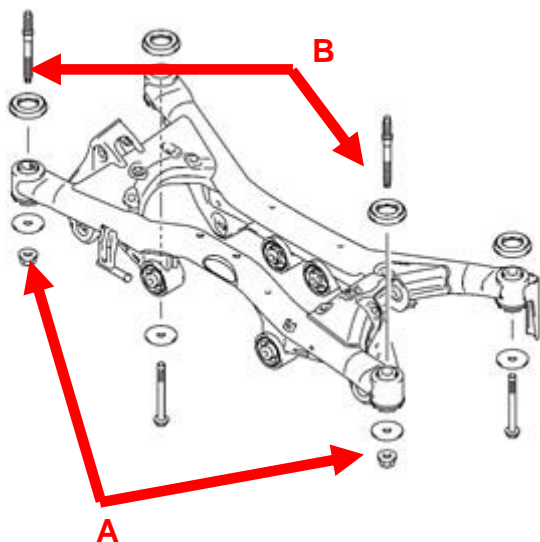

16. Remove the rear suspension frame rear bolts "A" with their washers.

17. Lower the transmission jack until the clearance between the rear left part of the rear suspension frame and the vehicle body becomes dimension "H".

Dimension H for front-wheel-drive models: 30 mm
Dimension H for all-wheel-drive models: 55 mm



▲ CAUTION

The rear suspension frame will become unstable and can drop off causing personal injury and vehicle damage when lowering the jack to lower the frame.

To prevent the rear suspension frame from being unstable and Dropping off, work with special care not to swing the rear suspension frame or move the vehicle body unnecessarily.

▲ CAUTION

If the rear suspension frame is lowered by more than dimension H, the propeller shaft and shock absorber could be damaged.

Do not lower the rear suspension frame more than dimension H.

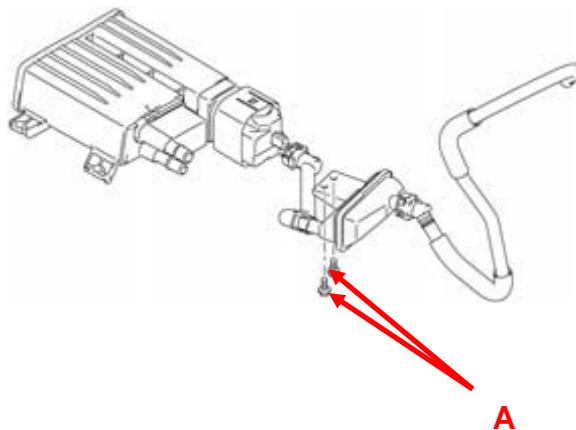

18. Remove the emissions canister suction filter bolts "A".

19. Locate the emissions canister pipe "A", canister filter "B" and canister air vent line "C".

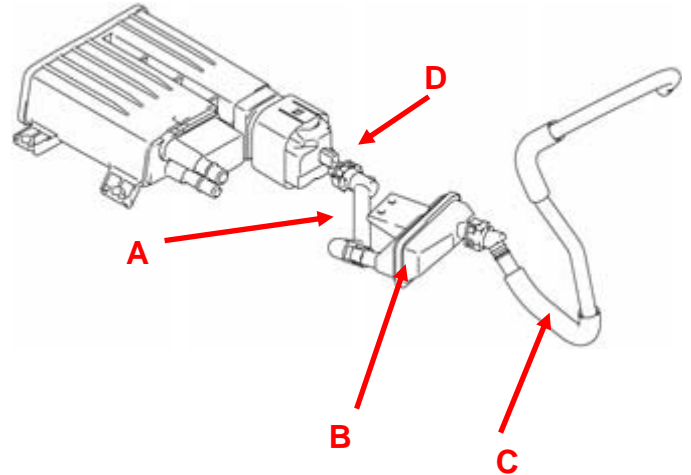

20. Disconnect the pipe "A" at connector "D".

a. Unlock the connector by squeezing the end of the connector to lift the locking tabs from the molded shoulder of the nipple.



21. To facilitate removal, inside the wheel well, cut the evaporative emissions canister air vent line at point "D".
22. Set aside (do not discard) the upper portion of the air vent line. Both the upper portion and lower portion of the air vent line just cut will be inspection later in this bulletin.



Step #23 is for front-wheel-drive models only.
For all-wheel-drive models skip this step and go to step 25.

23. Remove the emissions canister filter and vent tube from the location indicated in the photographs.
24. For front-wheel-drive models go to step 28.
For all-wheel-drive models go to step 25.

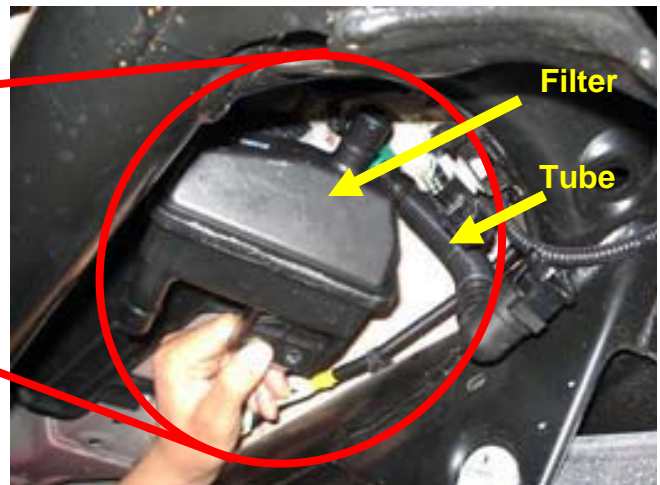
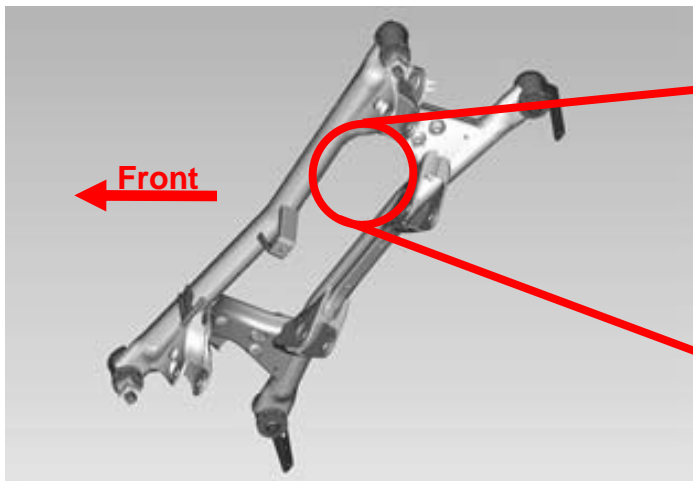

Steps 25, 26 and 27 are for all-wheel-drive models only.

25. Disconnect and reposition the electrical connector so that it is not damaged in the following steps.

▲ CAUTION

When moving the canister suction filter toward the rear of the vehicle, it may interfere with this wiring harness and damage the harness.

Move the canister suction filter carefully to avoid interference and prevent damage.



26. Place your hands through the clearance between rear suspension frame, drive shaft and control rod.



27. Move the emissions canister filter "A" toward the rear of the vehicle and remove through the clearance between rear suspension frame and vehicle body "B".

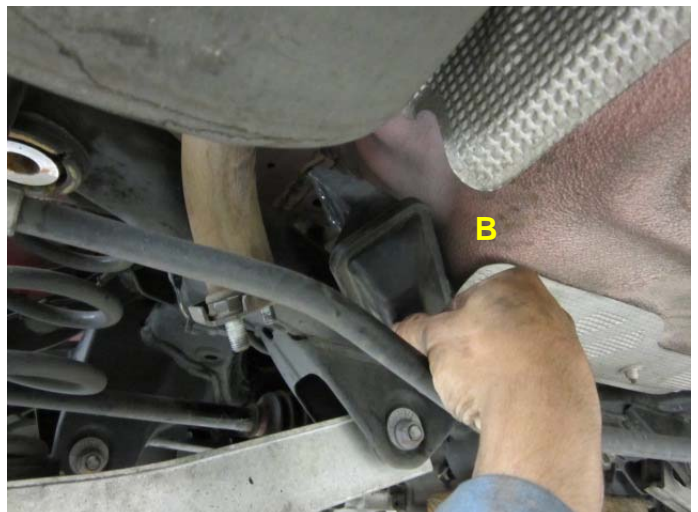

28. Cut the canister suction pipe at each position "A" to "M". Point "D" was cut in step 21.



29. Check for the presence of a spider web or parts of a spider web by inspecting the connector nipple part "A" of the canister filter. If a spider web "B" or parts of a spider web are found in the connector nipple part of the canister filter, remove the spider web. Re-use filter and replace the fuel tank if webs were noted. **Be sure to take a clear picture of the spider web before cleaning. Your warranty claim may be adjusted if you can not provide a clear photo of the web inside the filter nipple area.**



30. Check for the presence of a spider web or broken parts of a spider web by inspecting each cut section of the canister suction pipe "A". If a spider web or broken parts of a spider web are found inside any part of the vent tube, install a new fuel tank, then go to step 31. **Do not remove the webs from any tube section and keep all tube sections for warranty claim review if requested.**



Step #31 is for front-wheel-drive models only.

For all-wheel-drive models skip this step and go to step #33.

31. Position the emissions canister filter "A" and the new canister vent line "B" at their installed positions (do not fasten in place). Connect the canister vent line to the canister filter. A click sound will be heard when the connection has been made. Confirm that the connection is secure by lightly pulling the connector.

32. For front-wheel-drive models go to step #35.
For all-wheel-drive models go to step #33.

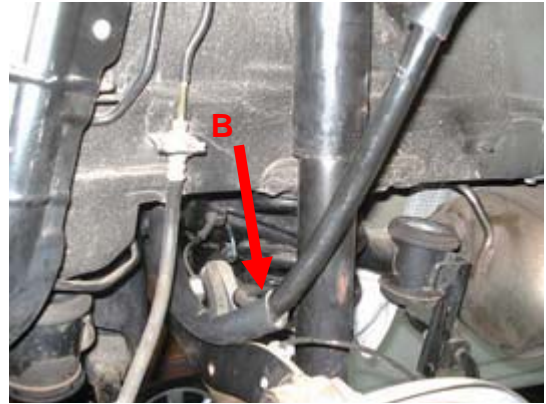

Step #33 is for all-wheel-drive models only.

33. Place the emissions canister filter at its installed position by inserting it between the rear suspension frame and vehicle body. Do not fasten in place.

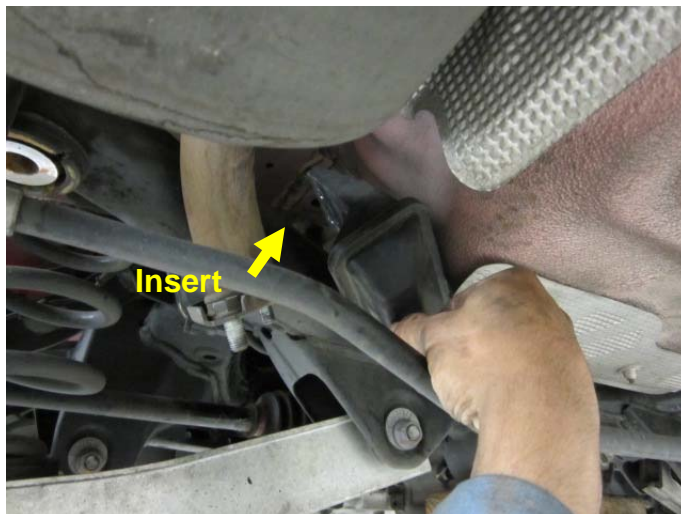

34. Place the emissions canister vent tube "A" at its install position and connect the canister vent line to the canister filter. A click sound will be heard when the connection has been made. Confirm that the connection is secure by lightly pulling the connector.



35. Connect the canister pipe "A". A click sound will be heard when the connection has been made. Confirm that the connection is secure by lightly pulling the connector.

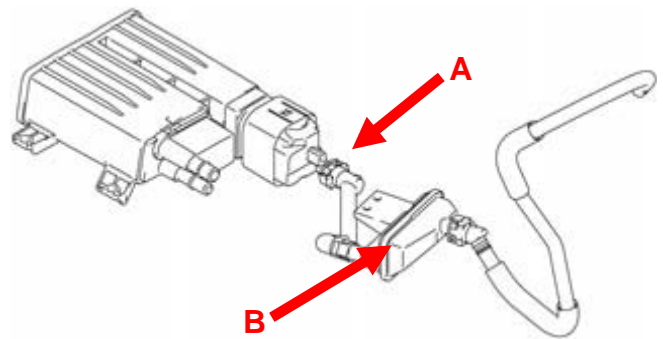

36. Install the canister filter bolts and tighten the bolts to the specification.

Tighten: 10 N.m (1.0 kgf-m, 7.5 lb-ft)



37. On All-Wheel-Drive vehicles, reconnect the electrical connector repositioned earlier.



38. Lift rear suspension frame into place and loosely install new rear suspension frame rear bolts included in the parts kit.

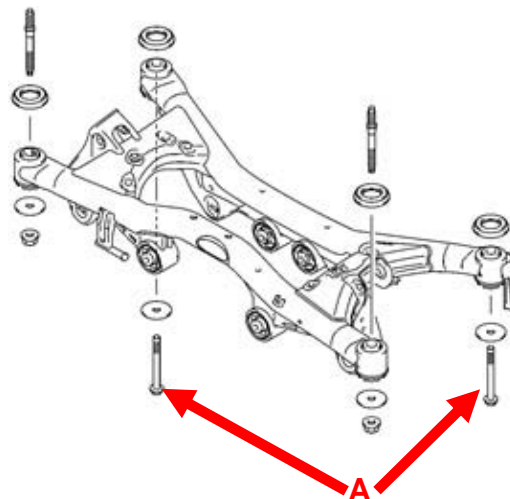

39. Remove the rear suspension frame front nuts and loosely install new rear suspension frame front nuts included in the parts kit.

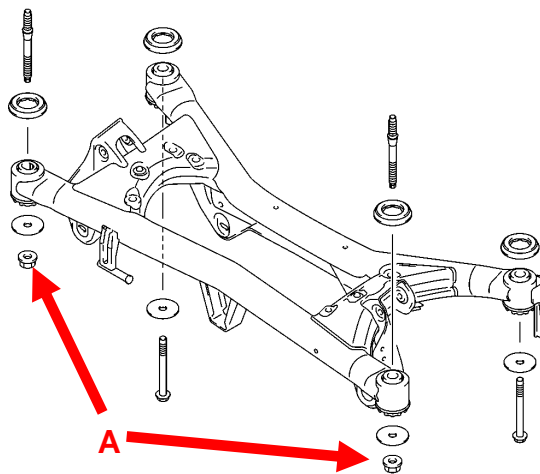

▲ CAUTION

If the rear suspension frame front nuts are completely pulled off of the stud bolt, the rear suspension frame may slip out of the transmission jack which may result in personal injury or damage to vehicle parts.

Do not remove the rear suspension frame front nuts completely until the rear suspension frame is verified to be securely positioned on the transmission jack.

40. Tighten the new rear suspension frame bolts and nuts:

Bolts: 110 N-m (11.2 kgf-m, 81.5 lb-ft)
Nuts: 110 N-m (11.2 kgf-m, 81.5 lb-ft)

41. Loosely install the rear suspension frame front bars "C" with the new bolts "A" and new nuts "B" included in the parts kit. Then tighten:

Bolts: 65 N·m (6.6 kgf-m, 48.0 lb-ft)
Nuts: 110 N·m (11.2 kgf-m, 81.5 lb-ft)

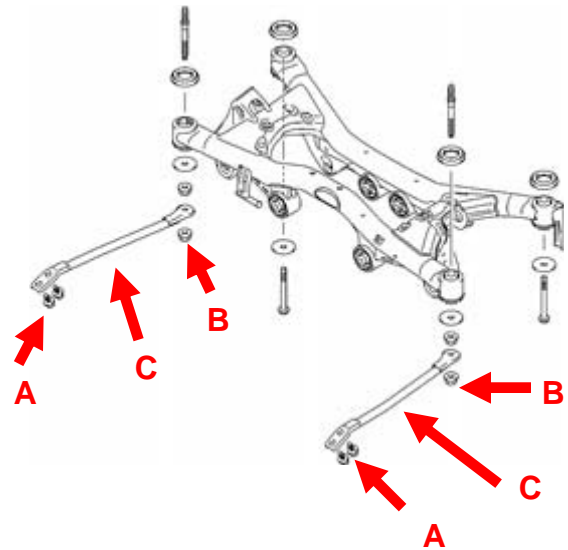

42. Re-install the exhaust pipe assembly at "A" and "B". Tighten exhaust pipe assembly:

"A": 50 N·m (5.1 kgf-m, 37.0 lb-ft)
"B": 50 N·m (5.1 kgf-m, 37.0 lb-ft)

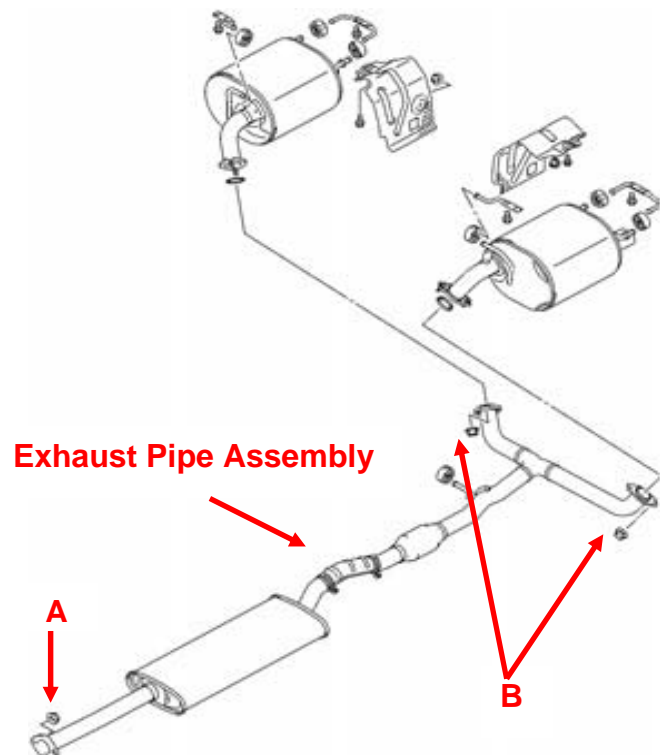

43. Install the cross-member. Tighten 4 places:

Bolts: 37 N·m (3.8 kgf-m, 27.5 lb-ft)



44. Install the underbody panels. Install 2 clips and 2 bolts. Tighten:

Bolts: 5.5 N-m (0.56 kgf-m, 4.0 lb-ft)

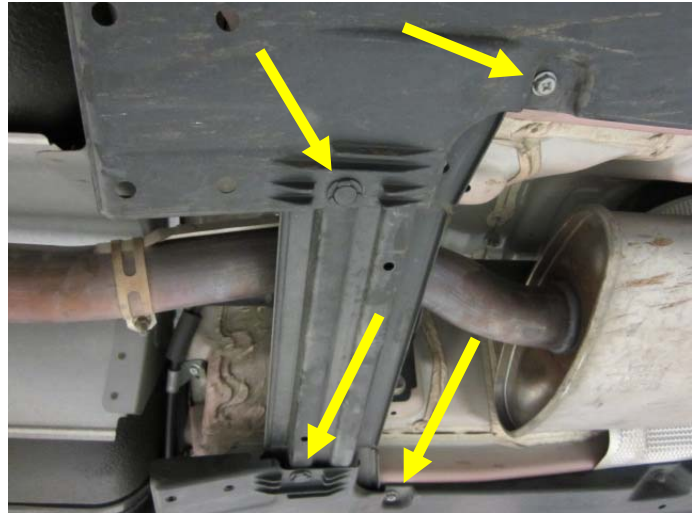

45. Install the emissions canister air vent line into its retaining clips.

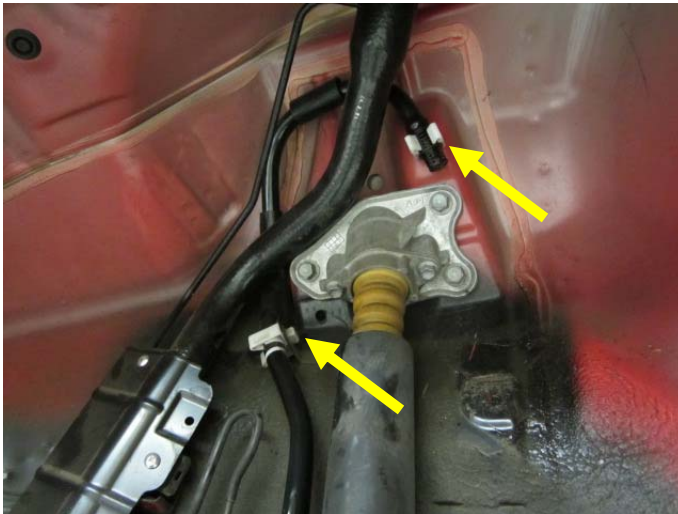

46. Position the fuel tank filler tube into place, remove the shop towel and install the fuel cap. Tighten the filler neck bolts:

Bolts: 3.0 N-m (0.3 kgf-m, 2.2 lb-ft)



47. Tighten the filler neck bolt at the wheel well:

Bolt: 5.5 N·m (0.6 kgf-m, 4.1 lb-ft)



48. Install wheel well cover at all points.



49. Install wheel. Tighten:

Lug Nuts: 140 N·m (14.3 kgf-m, 103.5 lb-ft)

50. Submit warranty claim through normal claim filing processes on Suzuki Connect. Reference SC-70 for claim submission information.