

June 13, 2014

BTB 51769 (1406)

## Safety Recall: ILX Headlights

### AFFECTED VEHICLES

Year	Model	Trim	VIN Range
2013–14	ILX, ILX Hybrid	Base (halogen headlights)	Check the iN VIN status for eligibility

### BACKGROUND

In certain conditions, the design of the headlight assembly will not allow sufficient heat dissipation when the vehicle is not in motion. Over longer periods of time, the higher temperatures may damage the reflector unit and, in extreme conditions, the headlight might overheat causing smoke, melting or fire.

### CORRECTIVE ACTION

Replace the left and right headlight assemblies with improved ones.

### CUSTOMER NOTIFICATION

Owners of affected vehicles will be sent a notification of this campaign beginning in July 2014.

Do an iN VIN status inquiry to make sure the vehicle is eligible.

Some vehicles affected by this campaign may be in your new or used vehicle inventory. These vehicles must be repaired before they are sold.

Should a dealership sell an unrepaired vehicle that subsequently causes an injury or damage because of the recalled item, the dealership will be solely responsible to the damaged party, and will be required to defend and indemnify American Honda for any resulting claims. To see if a vehicle in inventory is affected by this campaign, do a VIN status inquiry before selling it.

### PARTS INFORMATION

Part Name	Part Number	Quantity
Left Headlight Assembly	33150-TX6-A02	1
Right Headlight Assembly	33100-TX6-A02	1

### WARRANTY CLAIM INFORMATION

Operation Number	Description	Flat Rate Time	Template ID	Failed Part Number
7121J8	Replace the left and right headlight assemblies (includes headlight adjustment)	1.0 hr	14-018N	33150-TX6-A01

Defect Code: 5UX00

Symptom Code: JE900

Skill Level: Repair Technician

**CLIENT INFORMATION:** The information in this bulletin is intended for use only by skilled technicians who have the proper tools, equipment, and training to correctly and safely maintain your vehicle. These procedures should not be attempted by “do-it-yourselfers,” and you should not assume this bulletin applies to your vehicle, or that your vehicle has the condition described. To determine whether this information applies, contact an authorized Acura automobile dealer.

## REPAIR PROCEDURE

1. Remove the front bumper.
2. Remove the headlight with the corner upper beam as an assembly and disconnect the connectors.

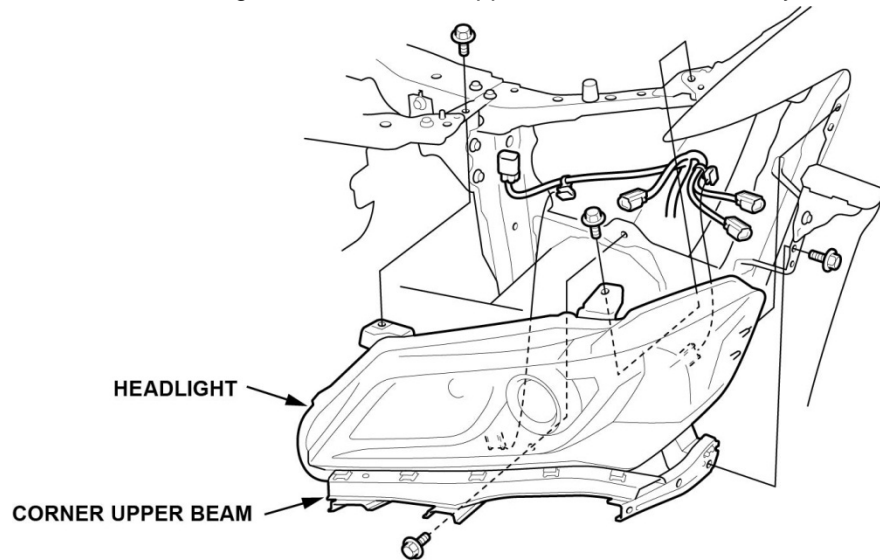

3. Remove the corner upper beam from the headlight.

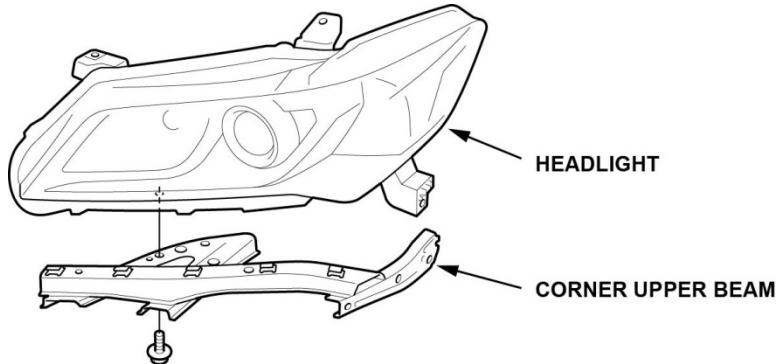

4. Install the corner upper beam to the new headlight and tighten the bolt to **9.3 N·m (6.9 lb-ft)**.

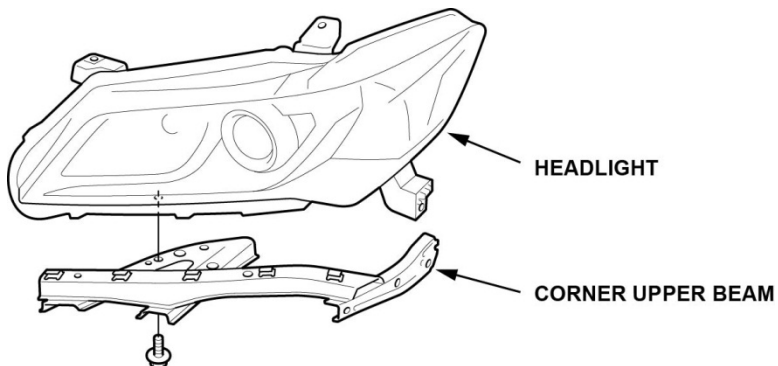

NOTE: Just in case the headlight assemblies get mixed up on your work bench, the improved head light assemblies

have the letter (A) in front of the date code.

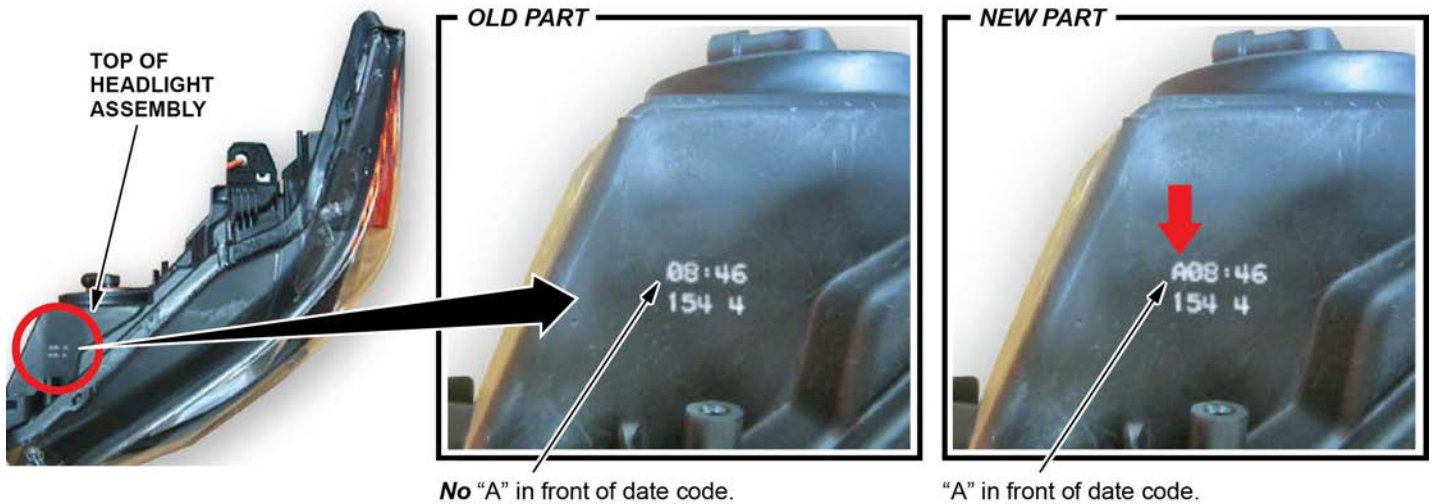

5. Install the new headlight, tighten the bolts to **9.3 N·m (6.9 lb-ft)** and reconnect the connectors. Then make sure the headlight bulbs are set into the headlight assembly.

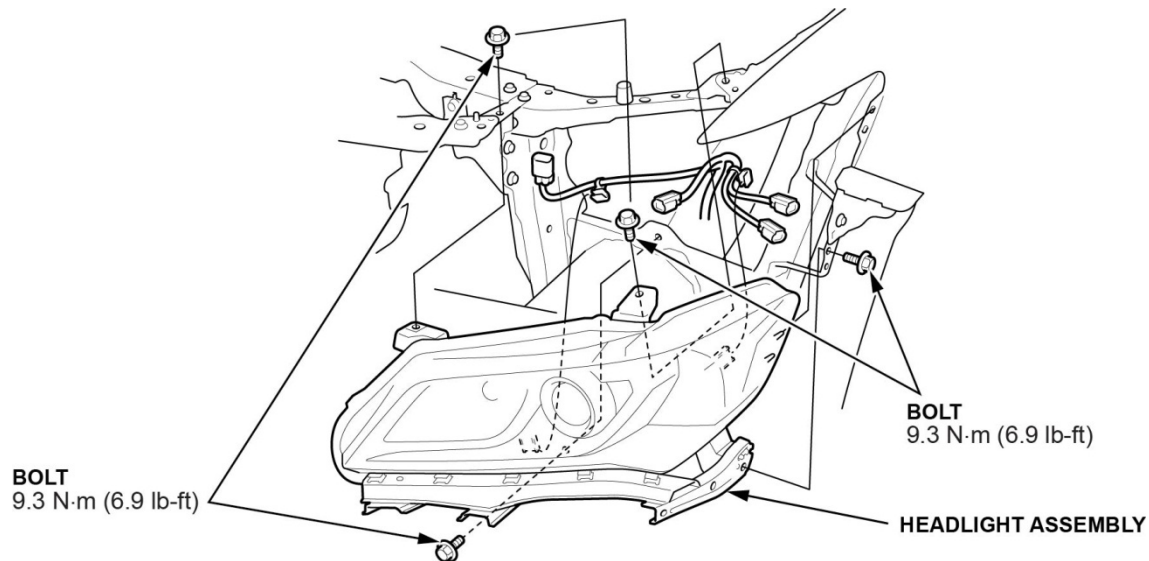

6. Repeat steps 2 through 5 on the other side.
7. Drill a  $\frac{1}{2}$ " hole in the lens of the old headlight assemblies to render them useless.
8. Before adjusting the headlights, do this:
  - Unload the vehicle.
  - Make sure the tire pressures are correct.
  - The driver or someone who weighs the same should sit in the driver's seat (or use an equivalent weight).
9. Make sure the outer lens is clean so that you can see the center of the headlights.

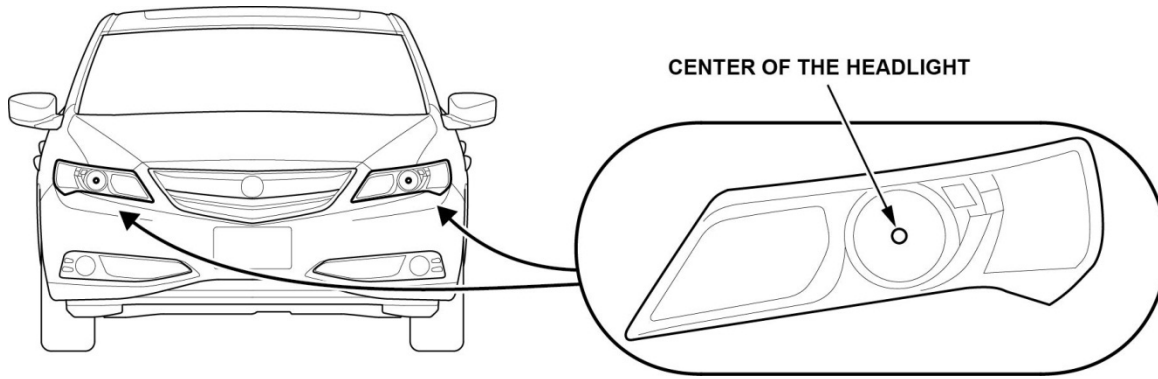

10. Park the vehicle on a level surface so that the center mark of the headlight is **7.5 m (24.6 ft)** away from a wall or screen.

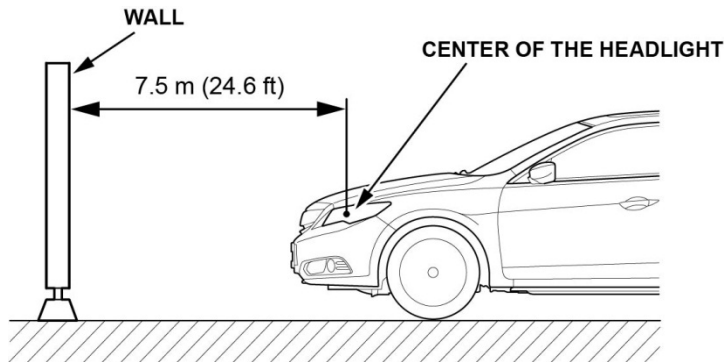

11. Measure the height of the headlight's center mark, then on the wall or screen, mark the same height of the headlights with masking tape in a straight line.

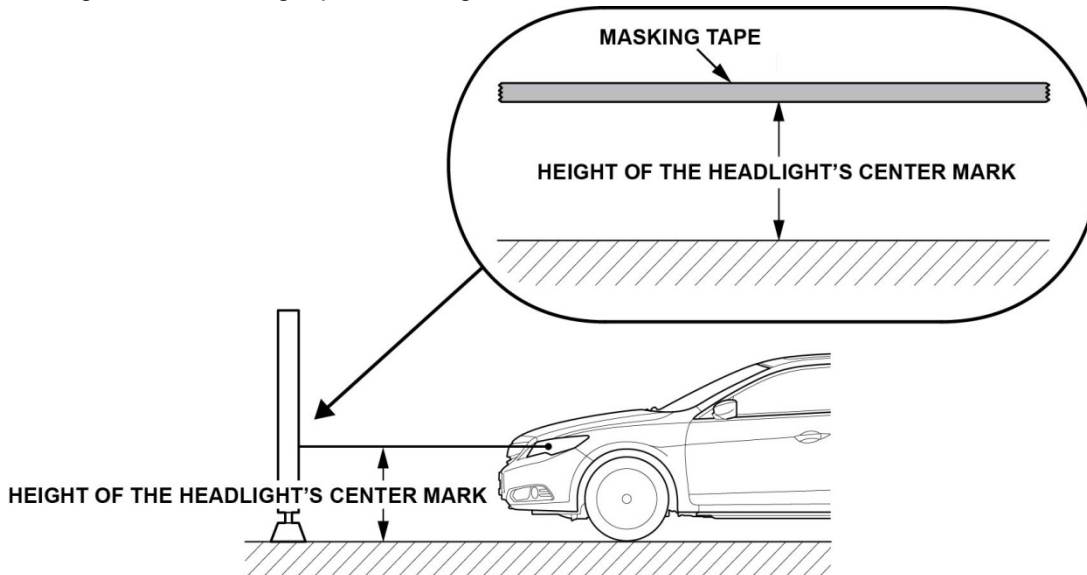

12. Turn on the low beam headlights.

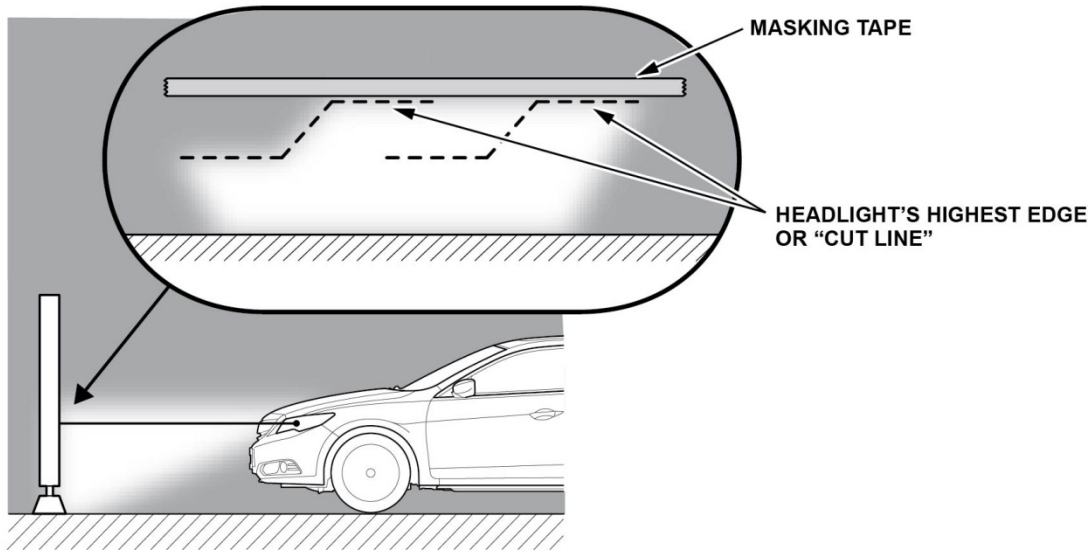

13. To see if the headlights are adjusted properly, look at the beams of the light projected on the wall or screen. The highest edge or cut line of the headlights should be equal with the masking tape.  
 NOTE: To help determine if a headlight is out of adjustment, block one of the beams with a large piece of cardboard or equivalent and look at the other beam on the wall or screen. Repeat this for the other headlight.
14. If adjustment is necessary, open the hood and adjust the headlights to local requirements by turning the adjuster.  
 NOTE: The headlights can only be adjusted vertically.

