

**May 15, 2014**

ATB 51545 (1405)

## Safety Recall: Right-Side Driveshaft

### AFFECTED VEHICLES

Year	Model	Trim	VIN Range
2013	Fit	ALL with M/T	Check the iN VIN status for eligibility

### BACKGROUND

Due to improper heat treatment, cracks may form, which can cause the right-side driveshaft to become inoperable when engine power is applied.

### CUSTOMER NOTIFICATION

Owners of affected vehicles will be sent a notification of this campaign in June 2014.

Do an iN VIN status inquiry to make sure the vehicle is shown as eligible.

Some vehicles affected by this campaign may be in your new or used vehicle inventory. These vehicles must be inspected, and if necessary, repaired before they are sold.

Should a dealership sell an unrepaired vehicle that subsequently causes an injury or damage because of the recalled item, the dealership will be solely responsible to the damaged party, and will be required to defend and indemnify American Honda for any resulting claims. To see if a vehicle in inventory is affected by this campaign, do a VIN status inquiry before selling it.

### CORRECTIVE ACTION

Inspect the vehicle's right-side inboard boot band, and depending on the serial number, replace the right-side driveshaft.

### PARTS INFORMATION

Part Name	Part Number	Quantity
Driveshaft Repair Kit (includes: Right-Side Drive Shaft Assembly, Spindle Nut, Drain Plug Washer 14 mm Drain Plug Washer 20 mm, Castle Nut, Set-Ring)	06440-TF0-305	1

### REQUIRED MATERIALS

Part Name	Part Number	Quantity
Moly 60 Paste (one tube repairs 50 vehicles)	08734-00001	1

### TOOL INFORMATION

Part Name	Tool Number	Quantity
Ball Joint Thread Protector	071AF-S3VA000	1
Ball Joint Remover	07MAC-SL0A202	1

Available through the Honda Tool and Equipment Program at **888-424-6857**.

**CUSTOMER INFORMATION:** The information in this bulletin is intended for use only by skilled technicians who have the proper tools, equipment, and training to correctly and safely maintain your vehicle. These procedures should not be attempted by "do-it-yourselfers," and you should not assume this bulletin applies to your vehicle, or that your vehicle has the condition described. To determine whether this information applies, contact an authorized Honda automobile dealer.

## WARRANTY CLAIM INFORMATION

### NOTE:

- When the warranty claim is filed and a part is replaced, you must retain the failed part for 30 calendar days after the final claim payment notification appears on your Weekly Warranty Claim Statement. Make sure to follow the warranty parts retention and return guidelines outlined in the Service Operations Manual, Sections 8.8, 8.9, and 8.10.
- **Make sure that you enter the right-side inboard boot serial number** in the DTC fields of the warranty entry screen. The 9-digit number will require using two DTC fields. Failure to enter the serial number may result in your claim being debited.

Operation Number	Description	Flat Rate Time	Template ID	Failed Part Number
2195A9	Inspect the right-side inboard boot band. Replacement not necessary.	0.3	14-024A	44305-TF0-N20
2191W8	Inspect right-side inboard boot band. Replace the driveshaft (includes alignment & test drive)	0.9	14-024B	

Defect Code: 5YY00

Symptom Code: JE400

Skill Level: Repair Technician

## DIAGNOSIS

1. Raise the vehicle on a lift.
2. Locate and write down on the RO the inboard boot band serial number located on the right side of the transmission. The warranty clerk will need the serial number to file a claim.

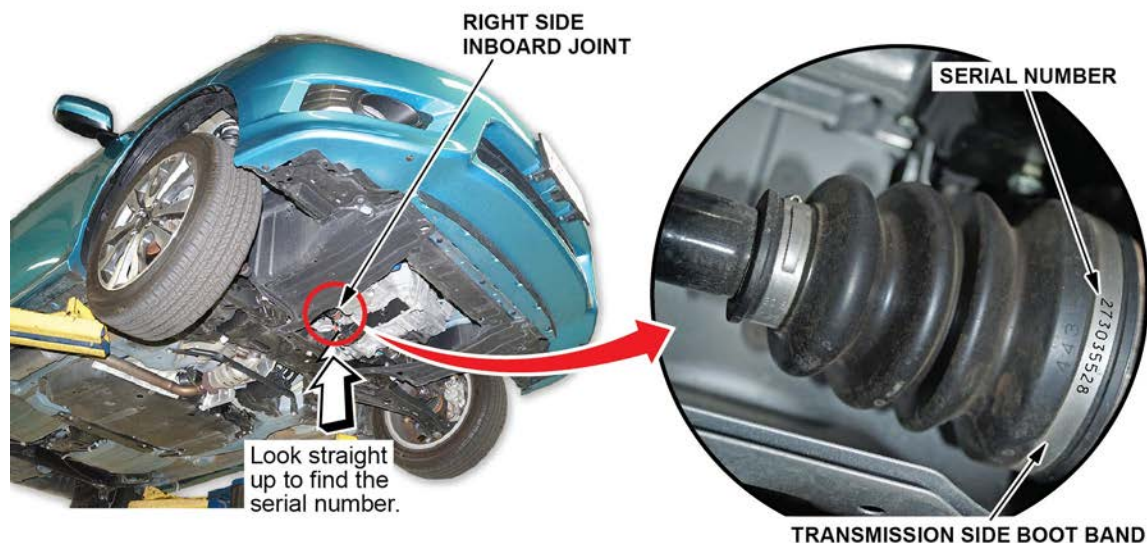

3. Compare the number from the boot band against the list below to determine if the driveshaft is affected.

- If the serial number is listed as **affected** based on the listed ranges, go to REPAIR PROCEDURE.
- If the serial number is listed as **not affected** based on the listed ranges, this bulletin does not apply.

**NOTE: Check the number you have written down on your RO and compare it to the list below. Only repair vehicles that have a boot band serial number from the list. To simplify the look-up on the list, use the first three digits of the boot band number to find the serial number in the table. For example, (352011697) will be in the third row.**

Starts with Boot Band Number	Serial Numbers
351	351012116 thru 351012163
351	351014236 thru 351014368
352	352011657 thru 352011737
352	352013525 thru 352013614
355	355000018
361	361000945 thru 361001014
361	361004290 thru 361004296
361	361012028 thru 361012087
362	362000842 thru 362000889
362	362003459 thru 362003511
365	365000099

## REPAIR PROCEDURE

1. Remove the passenger's front wheel.
2. Pry up the stake on the spindle nut, then remove the nut.

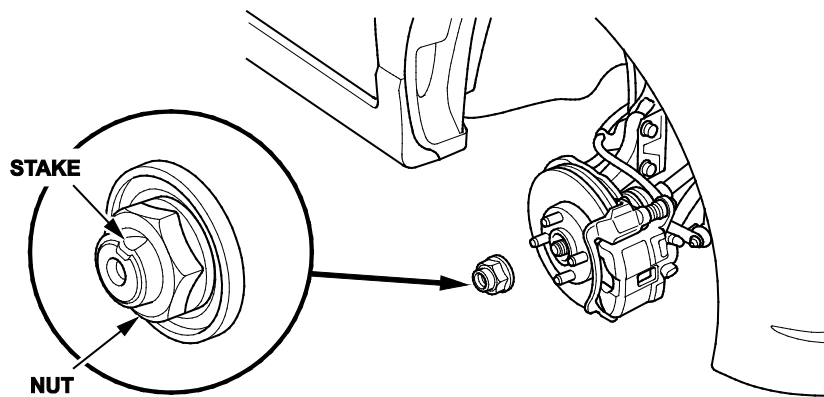

3. Remove the lock pin from the lower arm ball joint, then remove the castle nut. Separate the ball joint from the knuckle using a 14 mm ball joint thread protector and the 28 mm ball joint remover.

NOTE:

- To avoid damaging the ball joint, install the ball joint thread protector onto the threads of the ball joint.
- Be careful not to damage the ball joint boot when installing the remover.
- Do not force or hammer on the lower arm, or pry between the lower arm and the knuckle. You could damage the ball joint.

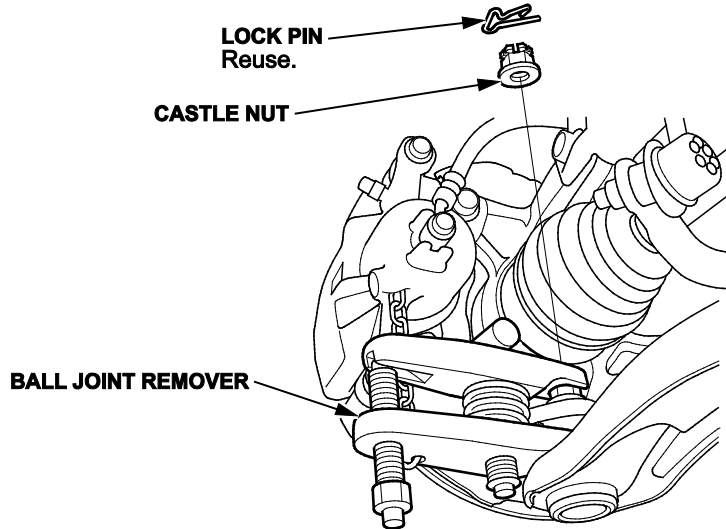

4. Pull the knuckle outward, and separate the outboard joint from the front hub using a plastic hammer.

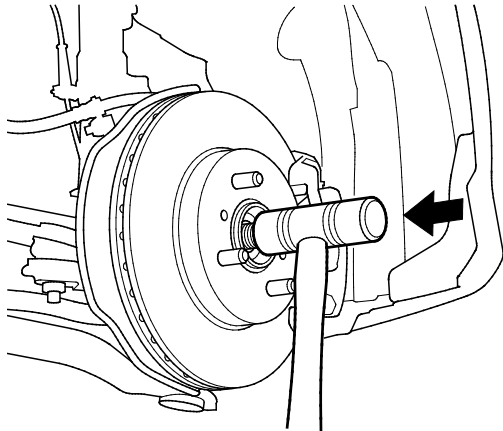

5. Pry the inboard joint from the differential using a pry bar. Remove the driveshaft assembly.

**NOTE:**

- Do not pull on the driveshaft, or the inboard joint may come apart. Pull the inboard joint straight out to avoid damaging the oil seal.
- Be careful not to damage the oil seal or the end of the inboard joint with the pry bar.

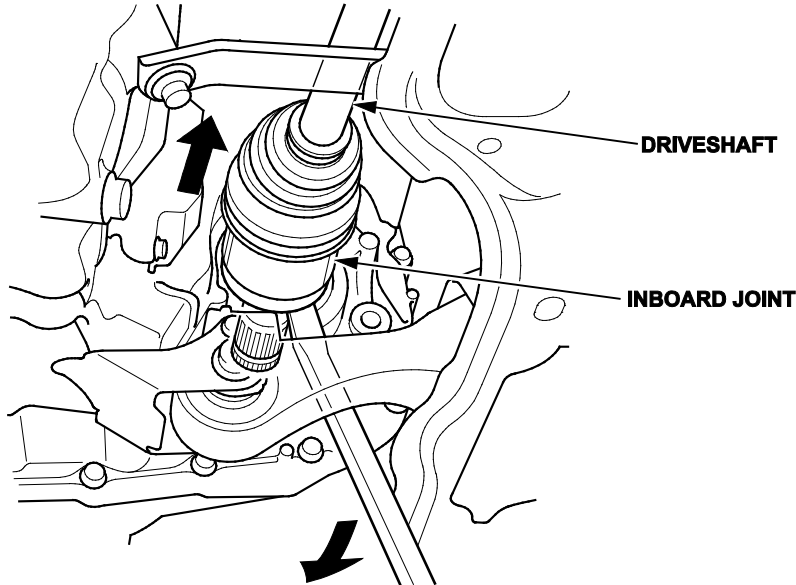

6. Apply about 5 g (0.18 oz) of moly 60 paste to the contact area of the outboard joint and the front wheel bearing to help prevent noise and vibration.

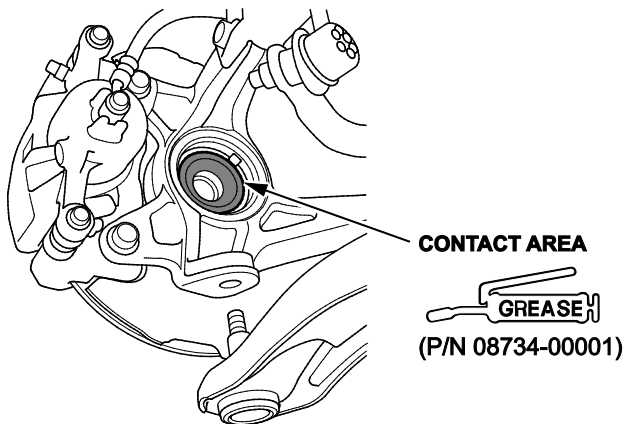

7. Clean the areas where the driveshaft contacts the differential thoroughly with solvent or brake cleaner, and dry them with compressed air.

**NOTE:** Do not wash the rubber parts with solvent.

8. Insert the inboard end of the new driveshaft into the differential until the set ring locks in the groove.

NOTE: Insert the driveshaft horizontally to prevent damaging the oil seal.

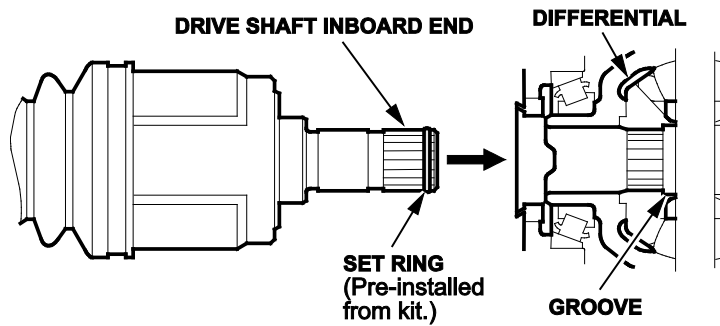

9. Install the outboard joint into the front hub on the knuckle.

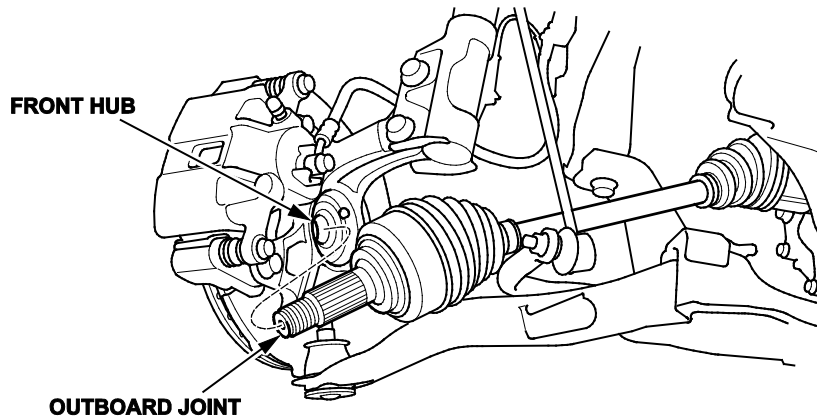

10. Wipe off any grease contamination from the ball joint tapered section and threads, then install the knuckle onto the lower arm. Be careful not to damage the ball joint boot. Wipe off the grease before tightening the castle nut at the ball joint. Torque the new castle nut to the lower torque setting **64-74 N·m (47-54 lb-ft)**, then tighten it only far enough to align the slot with the ball joint pin hole.

NOTE:

- Make sure the ball joint boot is not damaged or cracked.
- Do not align the nut by loosening it.

11. Install the lock pin into the ball joint hole.

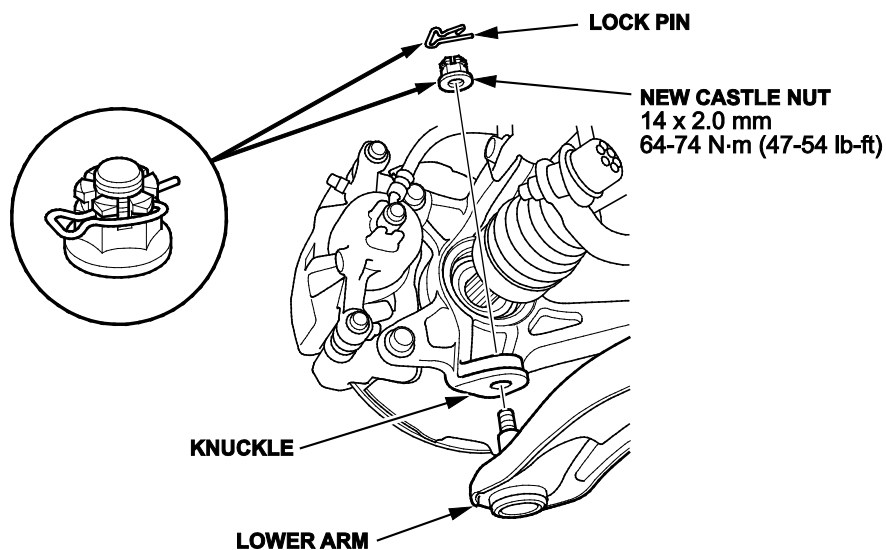

12. Apply a small amount of engine oil to the seating surface of the new spindle nut.
13. Install the spindle nut, then tighten it to **181 N·m (133 lb-ft)**. After tightening, use a drift to stake the spindle nut shoulder against the driveshaft.

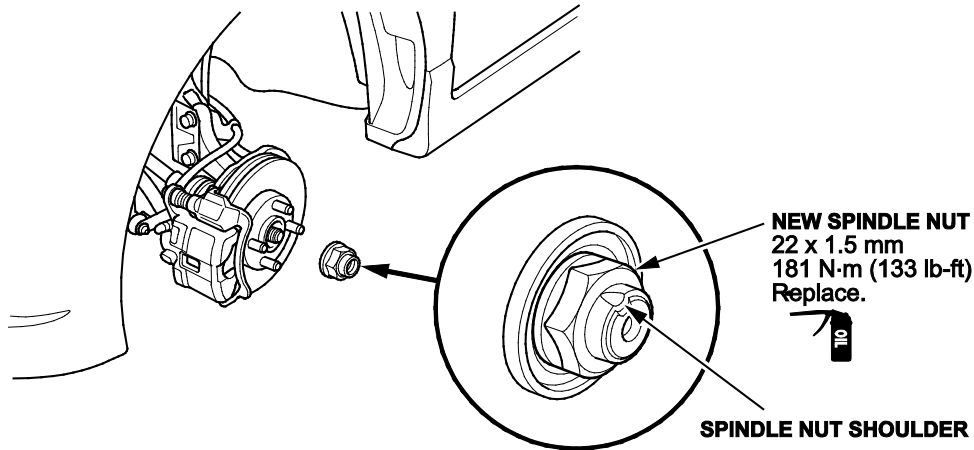

14. Clean the mating surfaces of the brake disc and the wheel, then install the front wheels.
15. Turn the front wheel by hand, and make sure there is no interference between the driveshaft and surrounding parts.
16. Check the MTF level; unscrew the filler bolt and check the fluid level. If it is low, fill it up, then install the new washer included in the kit.

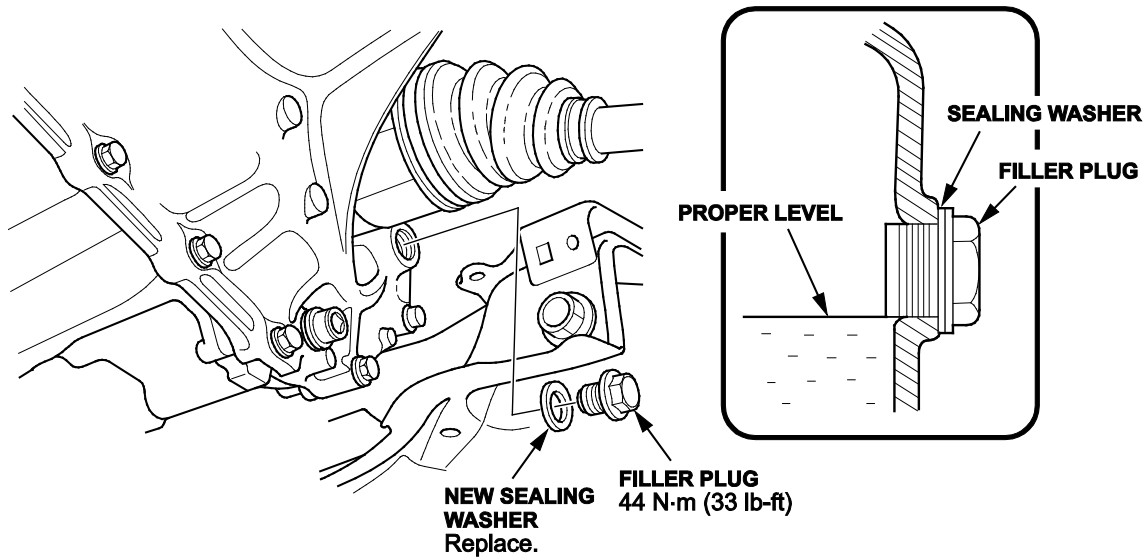

17. Lower the vehicle.
18. Do the wheel alignment.
19. Test-drive the vehicle.