



Recall Bulletin



PRODUCT SAFETY RECALL

SUBJECT: Transmission Shift Cable Fracture

MODELS: 2004-2007 Chevrolet Malibu Maxx
2004-2008 Chevrolet Malibu
2005-2008 Pontiac G6
2007-2008 Saturn AURA
Equipped with 4-Speed Automatic Transmission (ME7/MN5)

The Warranty Transaction Information section has been revised. The repair labor code has changed. Please discard all copies of bulletin 14152.

Due to part availability, this recall will be administered in phases. The first phase will be all AURA vehicles. As parts become available, the bulletin will be revised to include part numbers for the balance of the vehicles.

CONDITION

General Motors has decided that a defect which relates to motor vehicle safety exists in certain 2004-2007 model year Chevrolet Malibu Maxx, 2004-2008 model year Chevrolet Malibu, 2005-2008 model year Pontiac G6, and 2007-2008 model year Saturn AURA vehicles equipped with a 4-speed automatic transmission (ME7/MN5). These vehicles have a condition in which the transmission shift cable may fracture at any time. When the fracture occurs, the driver may not be able to select a different gear, remove the key from the ignition or place the transmission in park. If the driver cannot place the vehicle in park, and exits the vehicle without applying the park brake, the vehicle could roll away and a crash could occur without prior warning.

CORRECTION

Dealers are to install a shift cable assembly and mounting bracket.

VEHICLES INVOLVED

All involved vehicles are identified by Vehicle Identification Number on the Investigate Vehicle History screen in GM Global Warranty Management system. Dealership service personnel should always check this site to confirm vehicle involvement prior to beginning any required inspections and/or repairs. It is important to routinely use this tool to verify eligibility because not all similar vehicles may be involved regardless of description or option content.

For dealers with involved vehicles, a listing with involved vehicles containing the complete vehicle identification number, customer name, and address information has been prepared and will be provided to US and Canadian dealers through the GM GlobalConnect Recall Reports, or sent directly to export dealers. Dealers will not have a report available if they have no involved vehicles currently assigned.

The listing may contain customer names and addresses obtained from Motor Vehicle Registration Records. The use of such motor vehicle registration data for any purpose other than follow-up necessary to complete this recall is a violation of law in several states/provinces/countries. Accordingly, you are urged to limit the use of this report to the follow-up necessary to complete this recall.

PART INFORMATION

Parts required to complete this recall are to be obtained from General Motors Customer Care and Aftersales (GMCC&A). Please refer to your "involved vehicles listing" before ordering parts. Normal orders should be placed on a DRO = Daily Replenishment Order. In an emergency situation, parts should be ordered on a CSO = Customer Special Order.

Note: Due to part availability, this recall is being administered in phases. The first phase will be all AURA vehicles. As parts become available, the bulletin will be revised to include part numbers for the balance of the vehicles.

Part Number	Description	Quantity/Vehicle
23237999	Cable Kit, A/Trans Range Sel Lvr (AURA)	1
25907374	Bracket, A/Trans Range Sel Lvr Cbl (AURA)	1

SERVICE PROCEDURE

1. Remove and discard the floor shift control cable. Refer to *Floor Shift Control Cable Replacement* in SI.

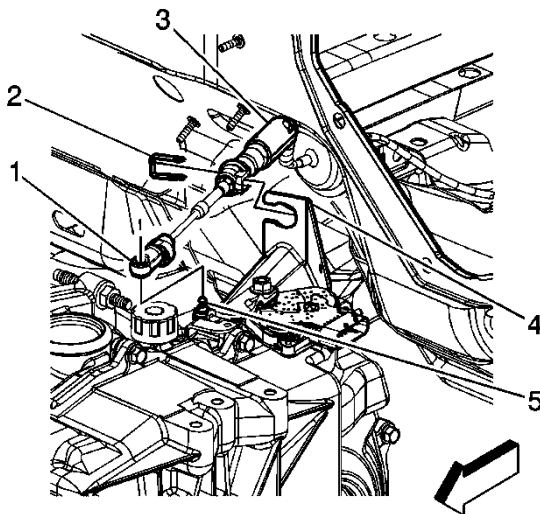

1765068

2. Remove and discard the shift cable bracket (4) attached to the transmission.

3. Install a new floor shift control cable and new bracket. Refer to *Floor Shift Control Cable Replacement* in SI.

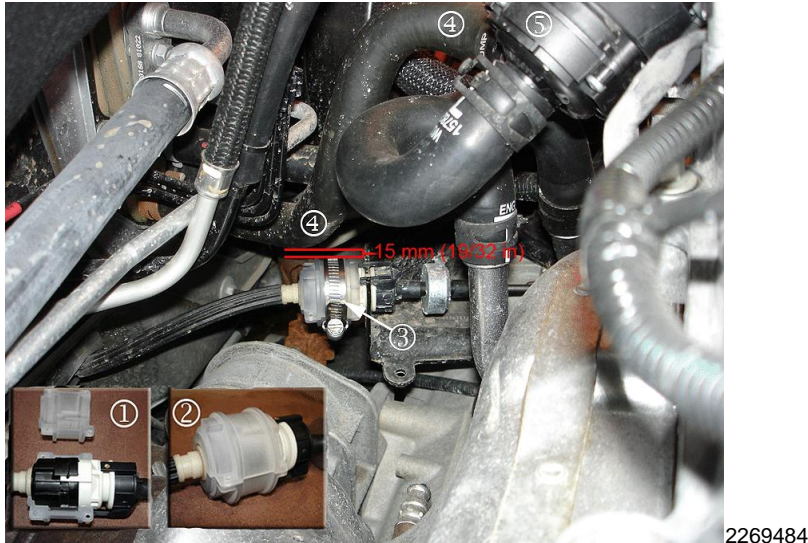

Hybrid vehicle shown. Combustion engine vehicle is similar.

- (1) Clam Shell in Two Pieces
- (2) Clam Shell Around Shift Cable Locking Tabs
- (3) Clamp on Clam Shell
- (4) Inlet Coolant Hose and
- (5) Heater Cooler Pump.

4. Install the clam shell (1) (2) over the shifter cable locking tabs.
5. Install the service clamp over the clam shell (3). Position the clamp fastener head away from the inlet coolant hose (4). **Tighten the clamp to 4 N·m (35 lb-in).**
6. Ensure that there is 15 mm (19/32 in) of clearance between the inlet coolant hose (4) and the clam shell (3). On hybrid equipped vehicles, it may be necessary to reposition the inlet coolant hose (4) to achieve the required 15 mm (19/32 in) of clearance. **To reposition the inlet coolant hose (4) on hybrid equipped vehicles, locate the heater cooler pump (5) and perform Steps 6.1-6.5.**

Caution: Do not kink or damage the inlet coolant hose (4) when repositioning the hose to obtain the 15 mm (19/32 in) clearance. To avoid damaging the hose clamp, use J-38185 or equivalent hose clamp pliers to loosen the hose clamp.

- 6.1. Remove the generator control module cover. Refer to *Generator Control Module Cover Replacement* in SI.
- 6.2. Using J-38185 or equivalent hose clamp pliers, loosen the inlet coolant hose (4) connected to the heater cooler pump (5). Note the location of the clamp on the inlet coolant hose (4).
- 6.3. Rotate the inlet coolant hose (4) clockwise until 15 mm (19/32 in) of clearance between the inlet coolant hose (4) and clam shell (3) is achieved.
- 6.4. Ensure that the inlet coolant hose clamp is secure on the inlet coolant hose (4) in the production location.
- 6.5. Install the generator control module cover. Refer to *Generator Control Module Cover Replacement* in SI.
7. Close the hood.

CUSTOMER REIMBURSEMENT - For US

Customer requests for reimbursement of previously paid repairs for the recall condition are to be submitted to the dealer by July 31, 2015, unless otherwise specified by state law. If this is not convenient for the customer, they may mail the completed Customer Reimbursement Request Form and all required documents to the GM Customer Assistance Center.

All reasonable and customary costs to correct the condition described in this bulletin should be considered for reimbursement. Any questions or concerns should be reviewed with your GM representative prior to processing the request.

When a customer requests reimbursement, they must provide the following:

- A completed Customer Reimbursement Request Form. This form is mailed to the customer or can be obtained through GM GlobalConnect.
- The name and address of the person who paid for the repair.
- Paid receipt confirming the amount of the repair expense, a description of the repair, and the person or entity performing the repair.

IMPORTANT: GM requires dealers to approve or deny a reimbursement request within 30 days of receipt. If a reimbursement request is approved, the dealer should immediately issue a check to the customer and submit an appropriate warranty transaction for the incurred expense. If a reimbursement request is denied, the dealer MUST provide the customer with a clear and concise explanation, in writing, as to why the request was denied. The bottom portion of the Customer Reimbursement Request Form may be used for this purpose. If the denial was due to missing documents, the customer can resubmit the request when the missing documents are obtained, as long as it is still within the allowed reimbursement period.

Warranty transactions for customer reimbursement of previously paid repairs are to be submitted as required by GM Global Warranty Management. Additional information can also be found in Warranty Administration Bulletin 11-00-89-004.

CUSTOMER REIMBURSEMENT - For Canada and Export

Customer requests for reimbursement of previously paid repairs to correct the condition described in this bulletin are to be submitted to the dealer prior to or by July 31, 2015.

When a customer requests reimbursement, they must provide the following:

- Proof of ownership at time of repair.
- Original paid receipt confirming the amount of unreimbursed repair expense(s) (including Service Contract deductibles), a description of the repair, and the person or entity performing the repair.

All reasonable and customary costs to correct the condition described in this bulletin should be considered for reimbursement. Any questions or concerns should be reviewed with your GM representative prior to processing the request.

COURTESY TRANSPORTATION – For US and Canada

The General Motors Courtesy Transportation program is intended to minimize customer inconvenience when a vehicle requires a repair that is covered by the New Vehicle Limited Warranties. The availability of courtesy transportation to customers whose vehicles are within the warranty coverage period and involved in a product program is very important in maintaining customer satisfaction. Dealers are to ensure that these customers understand that shuttle service or some other form of courtesy transportation is available and will be provided at no charge. Dealers should refer to the General Motors Service Policies and Procedures Manual for Courtesy Transportation guidelines.

WARRANTY TRANSACTION INFORMATION

Submit a transaction using the table below. All transactions should be submitted as a ZFAT transaction type, unless noted otherwise.

Note: To avoid having to "H" route the customer reimbursement transaction for approval, it must be submitted prior to the repair transaction.

Labor Code	Description	Labor Time	Net Item
9100564	Replace Transmission Shift Cable (inc install transmission shift cable kit) Add: Hybrid Vehicle	1.1 0.1	N/A
9100562	Customer Reimbursement Approved	0.2	*
9100563	Customer Reimbursement Denied - For US dealers only	0.1	N/A

Note: Customer reimbursement will not close this recall. The service procedure must also be performed on the vehicle.

* The amount identified in "Net Item" should represent the dollar amount reimbursed to the customer.

CUSTOMER NOTIFICATION – For US and Canada

General Motors will notify customers of this recall on their vehicle (see copy of customer letter included with this bulletin).

CUSTOMER NOTIFICATION – For Export

Letters will be sent to known owners of record located within areas covered by the US National Traffic and Motor Vehicle Safety Act. For owners outside these areas, dealers should notify customers using the attached sample letter.

DEALER RECALL RESPONSIBILITY – For US and Export (US States, Territories, and Possessions)

It is a violation of Federal law for a dealer to deliver a new motor vehicle or any new or used item of motor vehicle equipment (including a tire) covered by this notification under a sale or lease until the defect or noncompliance is remedied.

The US National Traffic and Motor Vehicle Safety Act provides that each vehicle that is subject to a recall of this type must be adequately repaired within a reasonable time after the customer

has tendered it for repair. A failure to repair within sixty days after tender of a vehicle is prima facie evidence of failure to repair within a reasonable time. If the condition is not adequately repaired within a reasonable time, the customer may be entitled to an identical or reasonably equivalent vehicle at no charge or to a refund of the purchase price less a reasonable allowance for depreciation. To avoid having to provide these burdensome remedies, every effort must be made to promptly schedule an appointment with each customer and to repair their vehicle as soon as possible. In the recall notification letters, customers are told how to contact the US National Highway Traffic Safety Administration if the recall is not completed within a reasonable time.

DEALER RECALL RESPONSIBILITY – All

All unsold new vehicles in dealers' possession and subject to this recall must be held and inspected/repaired per the service procedure of this recall bulletin before customers take possession of these vehicles.

Dealers are to service all vehicles subject to this recall at no charge to customers, regardless of mileage, age of vehicle, or ownership, from this time forward.

Customers who have recently purchased vehicles sold from your vehicle inventory, and for which there is no customer information indicated on the dealer listing, are to be contacted by the dealer. Arrangements are to be made to make the required correction according to the instructions contained in this bulletin. A copy of the customer letter is provided in this bulletin for your use in contacting customers. Recall follow-up cards should not be used for this purpose, since the customer may not as yet have received the notification letter.

In summary, whenever a vehicle subject to this recall enters your vehicle inventory, or is in your dealership for service in the future, you must take the steps necessary to be sure the recall correction has been made before selling or releasing the vehicle.

