



## MATERIAL

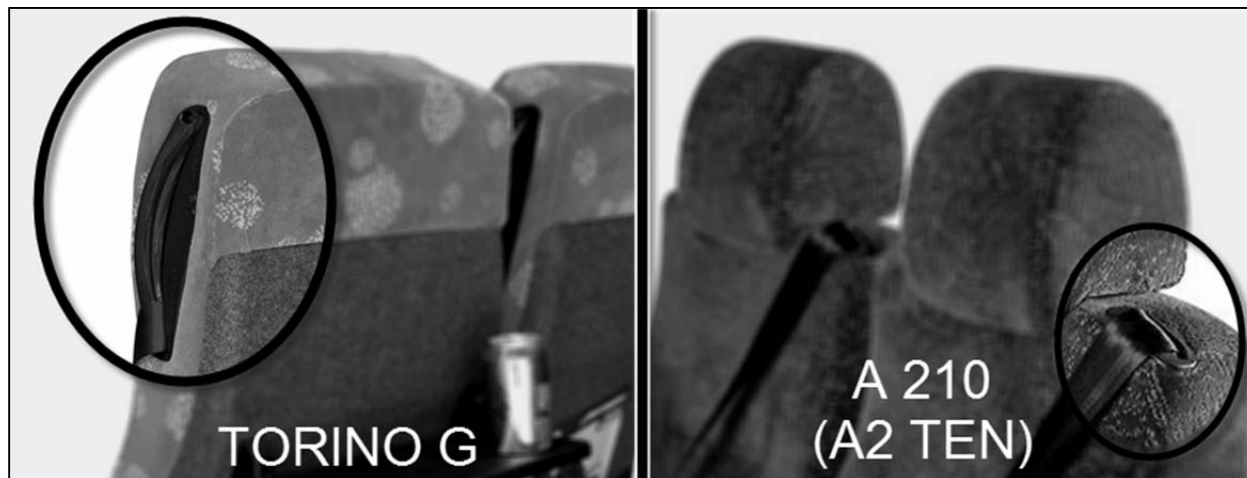

Figure 1: Seat differentiation

Depending on seat model (Fig 1), order one of the following kits for each belt to replace:

TORINO G seats: **SR14-26-1**" which includes:

Part No.	Description	Qty
864114	Replacement seat belt, <b>TORINO G</b>	1
500594	Hex Nut Nylon lock 7/16 x 20 GR8	1
5001734	Hex Screw 7/16 x 20 GR8	1
500897	Flat washer 0.438 x 1.0 x 0.083	1

A210 seats: "**SR14-26-2**" which includes:

Part No.	Description	Qty
865217	Replacement Seat belt <b>A210</b>	1
500594	Hex Nut Nylon lock 7/16 x 20 GR8	1
5001734	Hex Screw 7/16 x 20 GR8	1
500897	Flat washer 0.438 x 1.0 x 0.083	1

<b>NOTE</b>
<i>Material can be obtained through regular channels.</i>

## PROCEDURE



### DANGER

Park vehicle safely, apply parking brake, stop engine. In the battery box, set the battery cut-off switch to the OFF position prior to working on the vehicle.

The outboard (wall side) seat belt anchor of all flip-up seats must be inspected for damage. (fig 2 & 3).

**Note:** the damage to the belt can sometimes be hard to see. Use a flash light, if necessary and expose the underside of the belt that is located in and around the anchor loop.

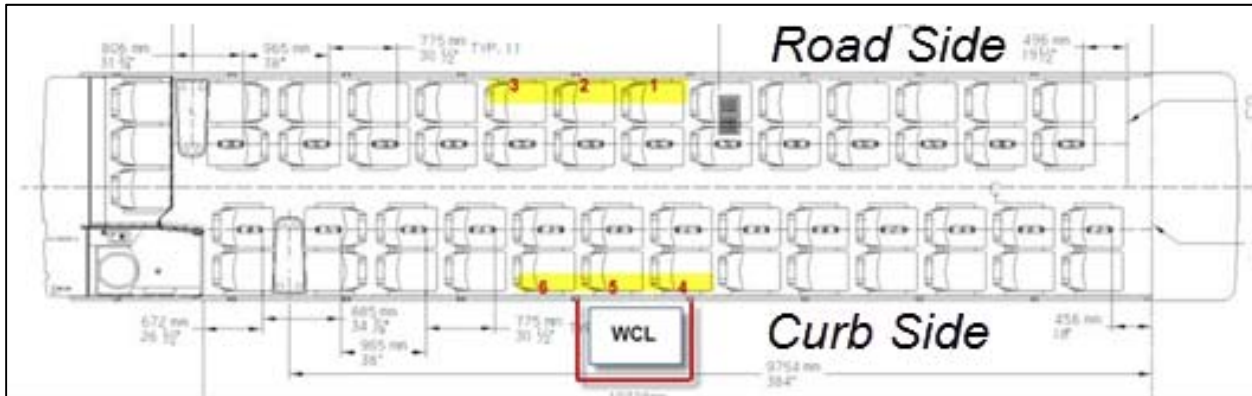

Figure 2

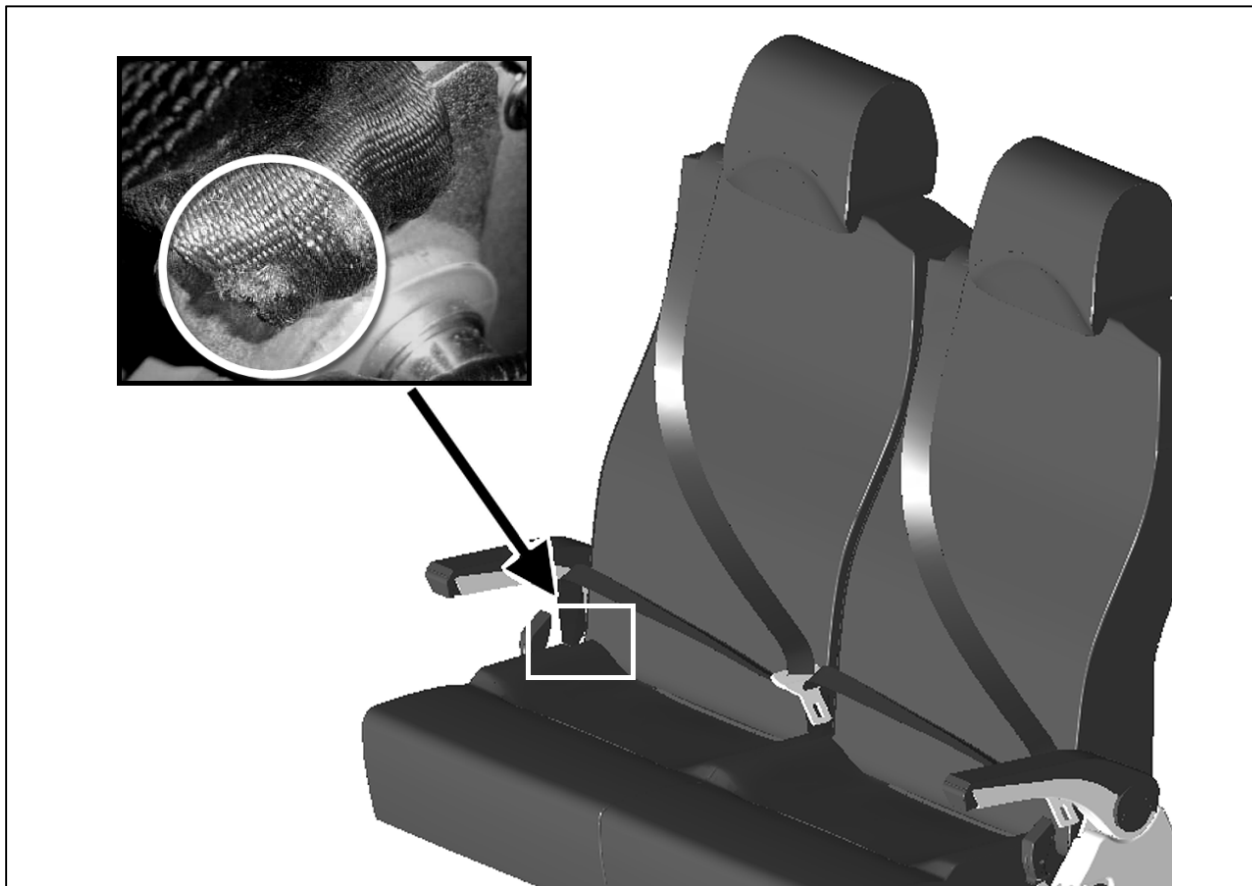

Figure 3: Typical belt damage (Curb side seat)

1. Remove seat cushion assembly bolts located at pivot location.

Two bolts, left and right. Remove wall side seat belt anchor (fig 4)

Keep hardware for re-use.

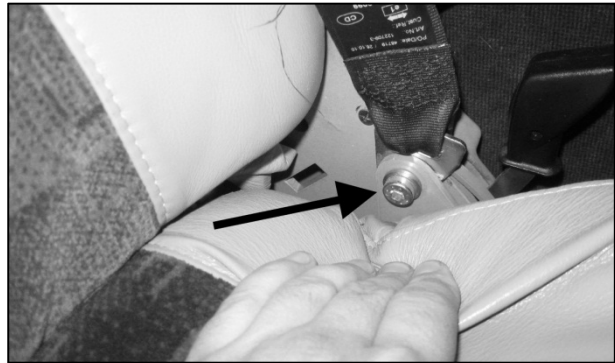

Figure 4 seat pivot and belt anchor (Road side)

2. Inspect belt condition.

If it is damaged (Fig 5), replace with a new belt.

For Torino G models, order kit SR14-26-1.

For A210 models, order kit SR14-26-2.

Order one kit per belt to replace.

Seat belt replacement instructions from AMAYA are included at the end of this document.

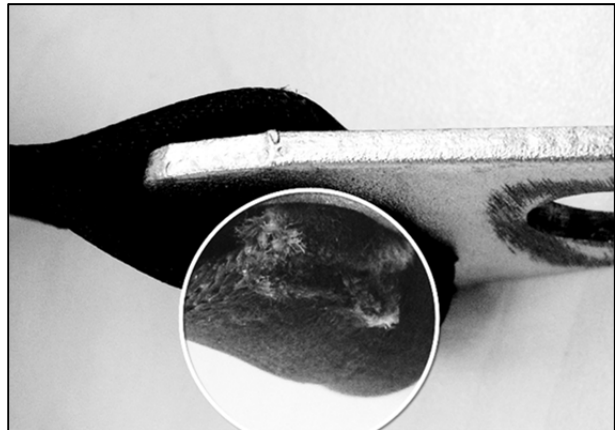

Figure 5: Typical Damaged belt

3. For Road Side seats only: Seat frame removal

*Make sure pedestals are locked in position before removing seat frame. Not doing so may compromise the sliding capacity of the seat.*

*Two persons are required for this step as seat may be heavy.*

Leave pedestals in locked position and remove seat from pedestals.

Front nuts are readily accessible.(Fig 6)

Keep hardware for re-use.



Figure 6 Front nuts.

4. Remove access panel (4 screws) to reach the rear nuts. (Fig 7).

Keep hardware for re-use.

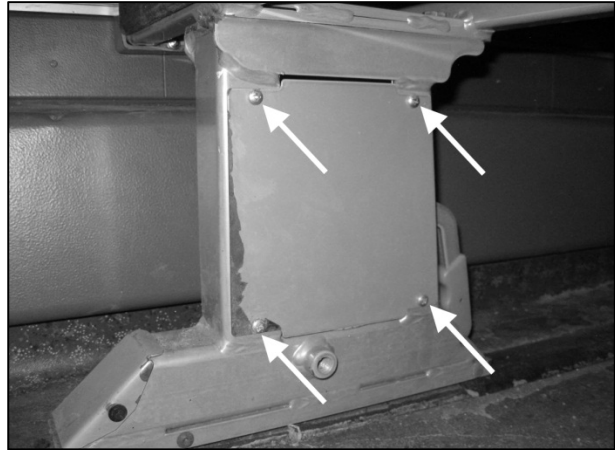

Figure 7: Access to rear nuts (Road side seat)

5. Remove the screws retaining the plastic cover, (Fig 8, Fig 9)  
(4 places, from the inside)

Long screwdriver tips may be required for the rear screws. Keep hardware.

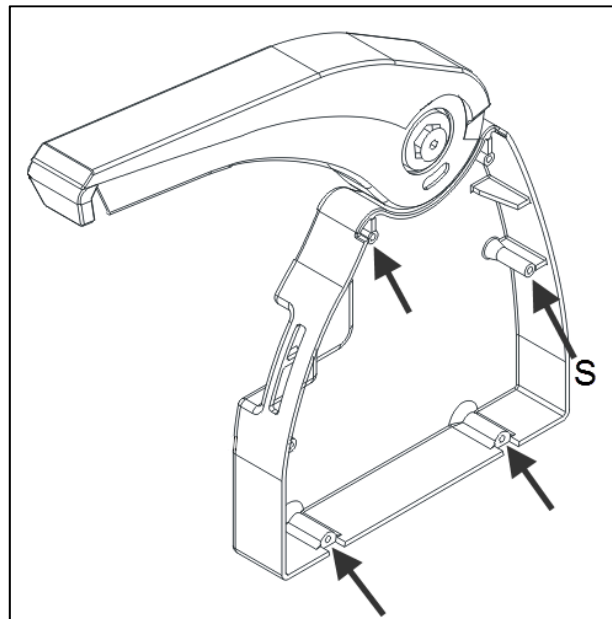

Figure 8: Screw locations

6. Rear screw "S" is in a blind location. You will find it near the upper rear cross tube of the seat frame above the adjustable flip cushion stopper.

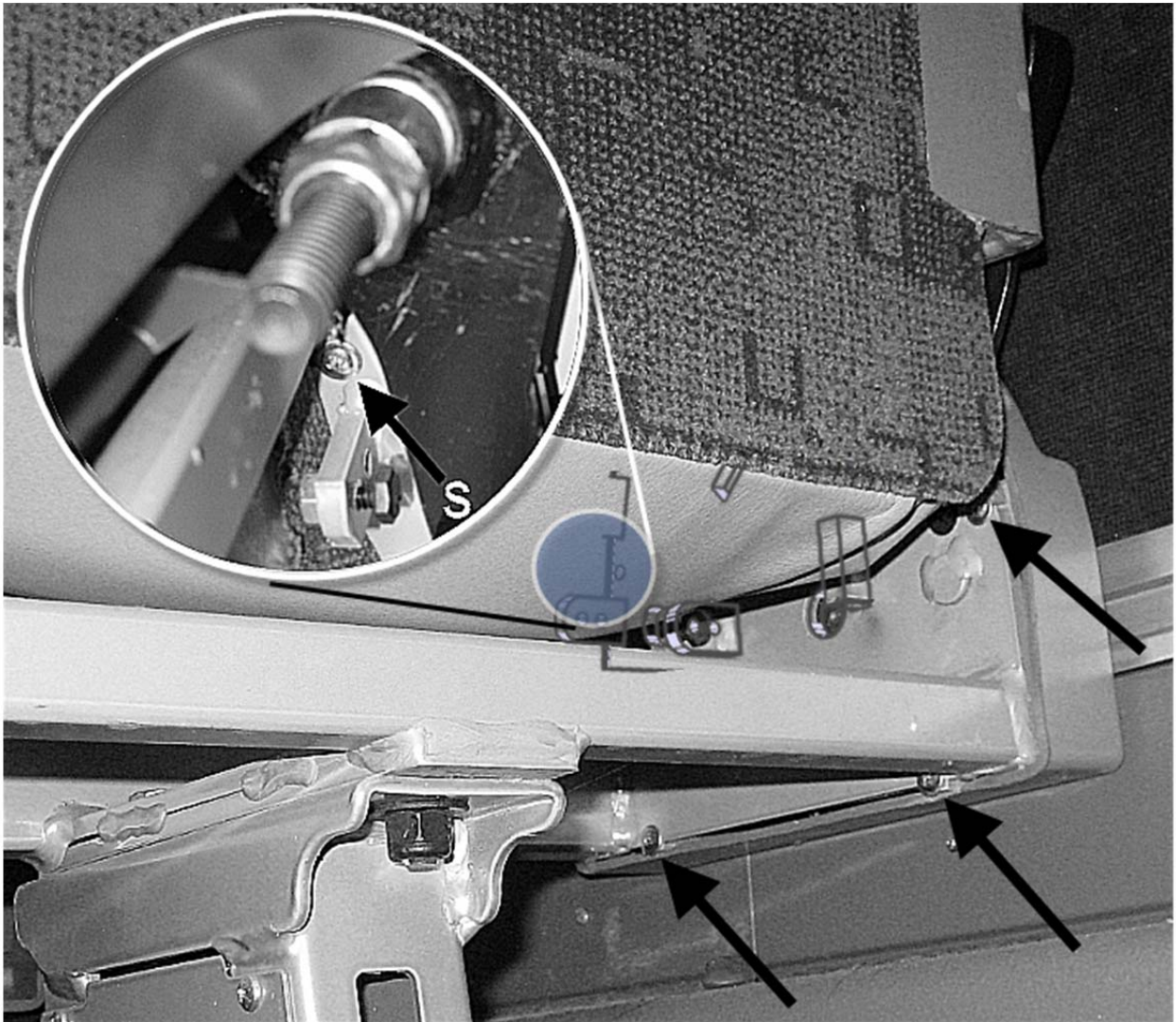

Figure 9: Blind screw "S" location

7. Re-install belt anchor in new location as shown, away from pivot. (Fig 10 & 11)

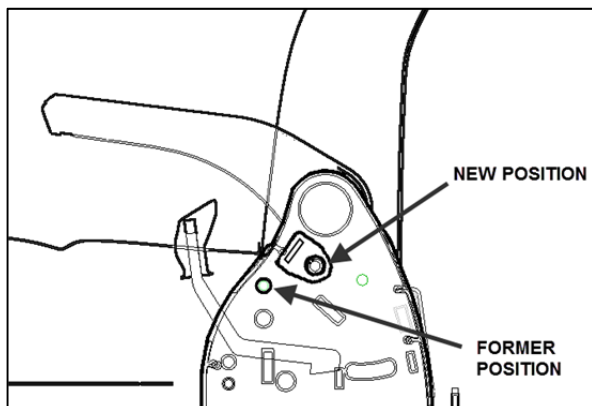

Figure 10: New position of belt anchor.

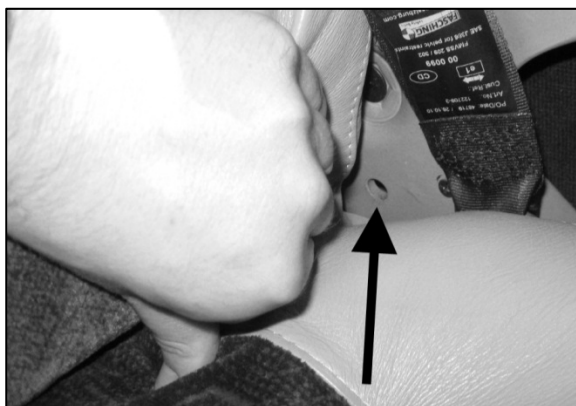

Figure 11: New position

8. Belt anchor plate should be installed parallel to seat frame.

Install with:  
5001734 Screw  
500897 Washer  
500594 Nut

**Tighten to:35 lbf-ft**

Apply torque seal mark to confirm belt relocation. (Fig 12)

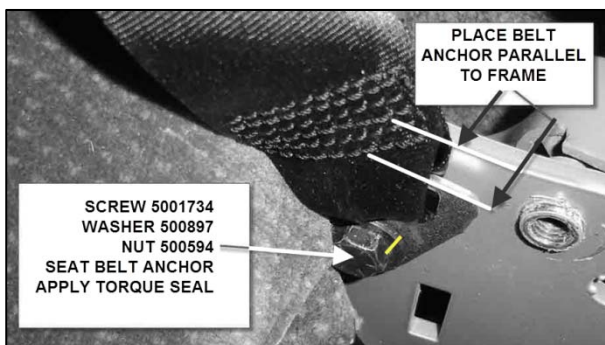

Figure 12: New hardware and torque seal

9. Plastic cover must be cut to provide clearance for new hardware.(Fig 13)
10. Re-install plastic cover
11. For road side seats: reinstall seats on pedestals

**Tighten to 27 lbf-ft.**

Reinstall access panels (Fig 7)

12. Re-install cushion assembly.(Fig 4)



Figure 13

## PARTS DISPOSITION

All replaced parts must be returned to Prevost according to the Return Shipping Instructions available on [www.prevostcar.com](http://www.prevostcar.com) (under service / warranty section) for full reimbursement. A copy of the warranty claim form must be enclosed with the shipment.

Discard waste according to applicable environmental regulations (Municipal/State[Prov.]/ Federal)

## WARRANTY

This modification is covered by Prevost's normal warranty. We will reimburse you one and a half hour ( 1½h ) for inspection and relocation of all belts affected by the recall, *and* for damaged belts only, the part(s) plus 15 minutes ( 1/4 h ) of labor per replaced belt up to a maximum of 6 belts (1 1/2h) upon receipt of the replaced parts and a completed A.F.A.

Please submit claim via our Online Warranty System, available at [www.prevostcar.com](http://www.prevostcar.com) (under service \ warranty section). Use Claim Type: "Bulletin/Recall" and select "Safety Recall SR14-26".

## OTHER

VBC Bulletin	n/a
Fail Code	18.03-2
Defect Code	09
Syst.Cond.	R
Causal Part	864115

Access all our Service Bulletins on  
<http://prevostparts.volvo.com/technicalpublications/en/pub.asp>  
or scan the QR-Code with your smart phone.

E-mail us at [technicalpublications\\_prev@volvo.com](mailto:technicalpublications_prev@volvo.com) and type  
"ADD" in the subject to receive our warranty bulletins by e-mail.

