



SERVICE REPAIR PROCEDURE

14V-180 Repair Procedure Instructions

14V-180

Page - 1 - of 2

BY: Timothy Downey

DEPARTMENT: Compliance

DATE: 10/16/2013

REVISION: A

MODEL:

Installation procedure is applicable to the following models of vehicle;

Trans Tech Bus SST

Trans Tech Bus ST-Aero

Trans Tech Bus Roadstar

Trans Tech Bus CST

Trans Tech Bus SST-FFL

ISSUE:

The vehicle may have improperly installed seat legs on 39SB11 and/or 39QS11 model C.E. White seats. This installation does not conform to the requirements of CFR 49 Section 571.207 and 571.210 regulations.

PROCEDURE:

- Vehicle Preparation -

1. The ignition key must be off to perform this procedure.
2. Make sure proper safety attire is worn during this procedure.
3. Vehicle parking brake is engaged.
4. Ensure there is adequate lighting and ventilation to perform this procedure. Additional lighting may be required to be able to properly view the repair area under certain conditions.

- Required Tools -

1. Measuring Tape
2. 1/2" Drill Bit
3. Portable Screw Gun
4. Phillips Head Bit
5. 7/16" Socket
6. Hydraulic over Pneumatic Rivet Gun

- Available Trans Tech Supplied Parts & Equipment -

1. Additional Leg Install Kit (for 39QS11 Seats) Trans Tech Part #600680
2. Tether Install Kit (for 39SB11 Seats) Trans Tech Part #600679



SERVICE REPAIR PROCEDURE

14V-180 Repair Procedure Instructions

14V-180

Page - 2 - of 2

BY: Timothy Downey	DEPARTMENT: Compliance	DATE: 10/16/2013	REVISION: A
--------------------	------------------------	------------------	-------------

- Inspection -

Using the attached VIN list, begin inspecting buses that have 39" seating from C.E. White installed. The measurement that the leg must be at is 28.375". Seats that do not comply are at any point closer to the wall than this dimension.

Subsequently, you should fill out the included response card and begin mailing of the card for the type and quantity of repair kits is required.

- Repair -

Using the attached engineering drawings, alter the mounting anchorages to match the approved assembly method. All fasteners and equipment not counting tools should be included for your convenience.

Subsequently, when repairs are completed, you should fill out the included response card and begin mailing of the card for the reimbursement of labor time and other materials if applicable.

At this point, test and check the entire system ensuring that it all works as originally designed. Clean the entire area from all solvents, dirt and remaining installation materials.

REPAIR OPERATION TIME: #600679 Repair (39SB11 Repair) – 15 Minutes per tether.
#600680 Repair (39QS11 Repair) – 35 Minutes per leg.

OTHER APPLICABLE ARTICLES: Not Applicable

WARRANTY STATUS: Warrantable

8

7

6

5

4

3

2

1

NOTES:

- 1) MATERIAL TO BE: SEE INDIVIDUAL PARTS
- 2) FINISH TO BE: SEE INDIVIDUAL PARTS
- 3) USE ELECTRONIC STEP FILE FOR 3D GEOMETRY, AND THIS DRAWING FOR MATERIAL SPECS AND CHECK DIMENSIONS.

REVISIONS					
ZONE	REV.	DESCRIPTION	DRAWN	DATE	APPROVED

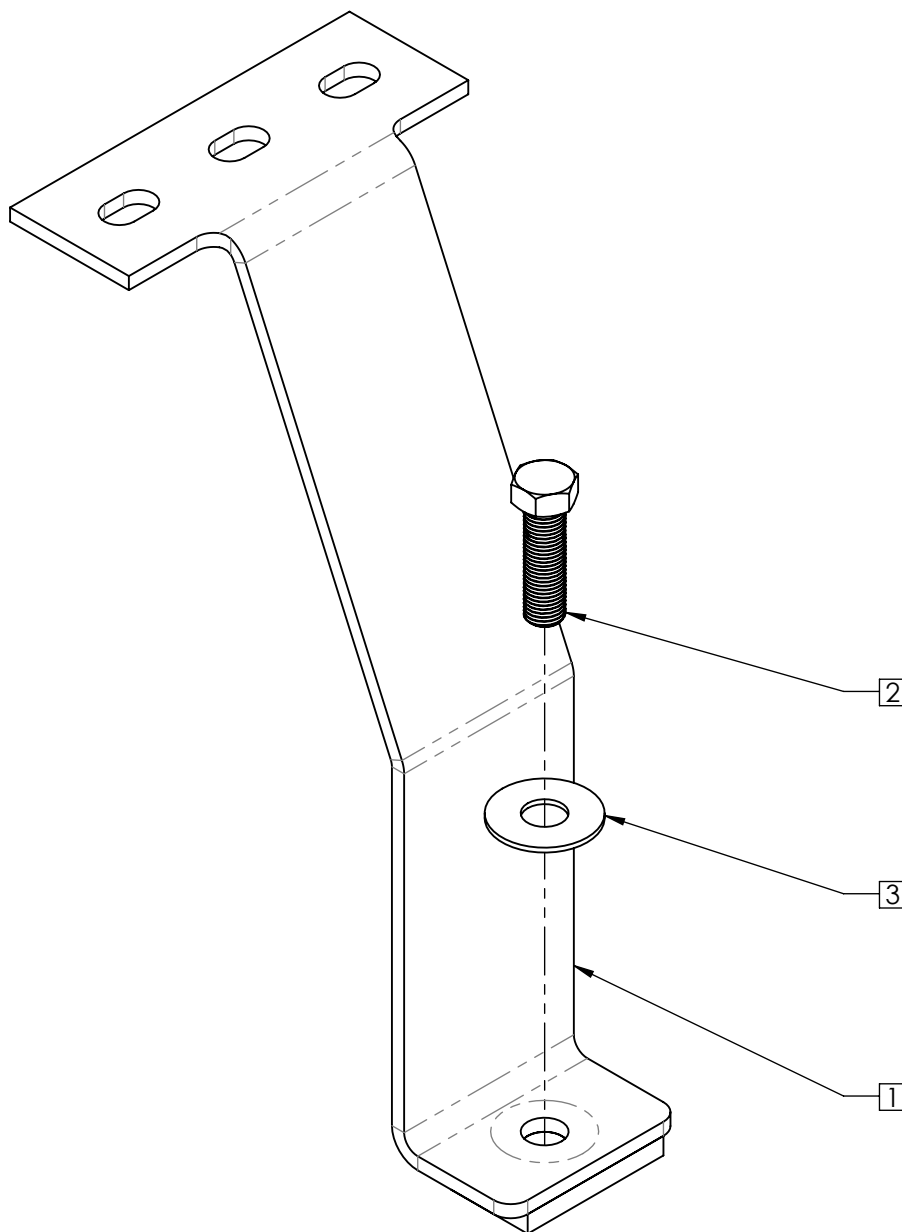

ITEM NO.	PART NUMBER	Rev	DESCRIPTION	QTY.
1	600670	-	LEG REINFORCEMENT, CE WHITE, STANDARD	1
2	600681	-	CAP SCREW, 7/16-20x1-1/2, HEX, GRADE 8, ZINC PLATED	1
3	589310	-	1/2" ID x 1-1/4"OD WASHER	1

UNLESS OTHERWISE SPECIFIED: DIMENSIONS ARE IN INCHES TOLERANCES ANGULAR ± 1° DECIMAL X.XXX ± 0.031 X.XX ± 0.063 FRACTIONAL ± 1/8			<h1 style="text-align: center;">TRANS TECH</h1> <p style="text-align: center;"><i>a TCI Company</i></p>		
PROPRIETARY AND CONFIDENTIAL THE INFORMATION CONTAINED IN THIS DRAWING IS THE SOLE PROPERTY OF TRANS TECH BUS. ANY REPRODUCTION IN PART OR AS A WHOLE WITHOUT THE WRITTEN PERMISSION OF TRANS TECH BUS IS PROHIBITED.					
MODEL	CJI	4/7/2014	SIZE	PART. NO.	REV
DRAWN	CJI	4/7/2014	B	600679	-
APPROVED	-	-	SCALE: 1:2	-	SHEET: 1 OF 1
Published on: Wednesday, April 09, 2014					

8

7

6

5

4

3

2

1

8 7 6 5 4 3 2 1

D

D

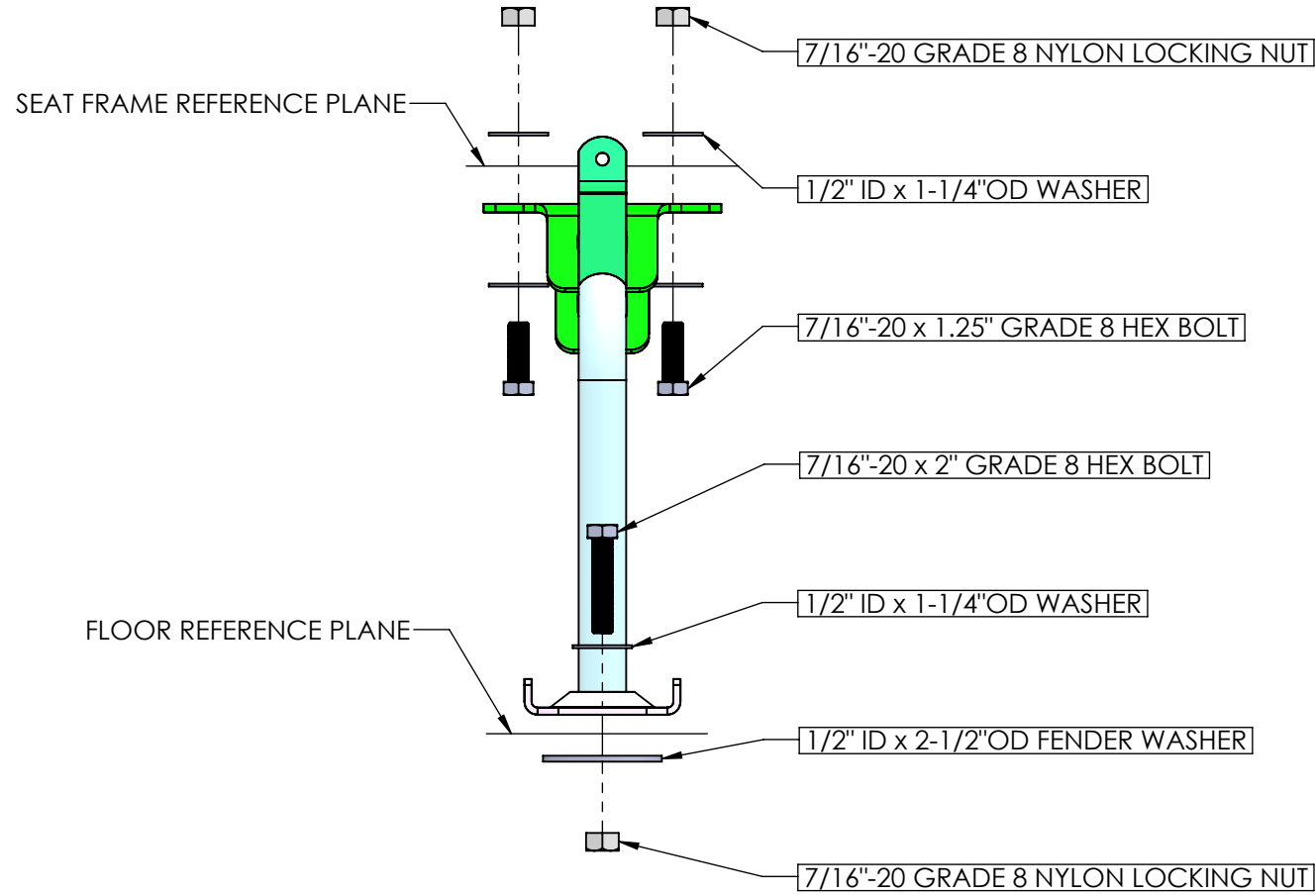

SEAT FRAME REFERENCE PLANE

FLOOR REFERENCE PLANE

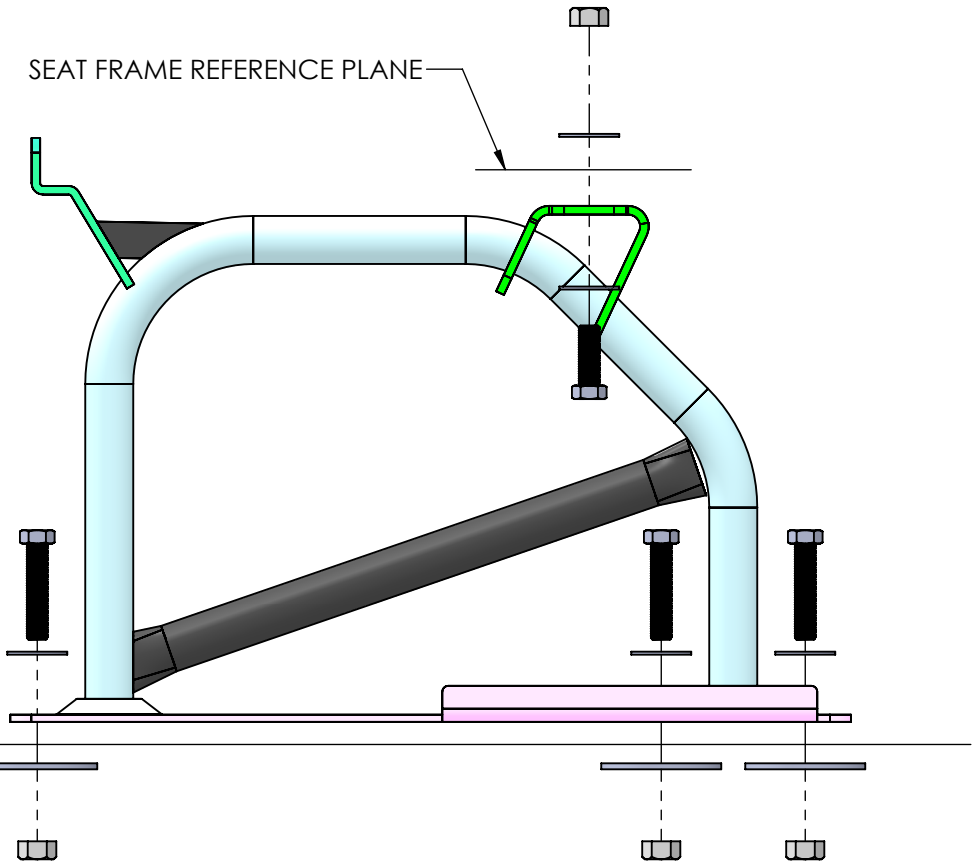

EXPLODED VIEW OF ADDITIONAL LEG WITH MOUNTING HARDWARE

B

B

A

A

UNLESS OTHERWISE SPECIFIED: DIMENSIONS ARE IN INCHES TOLERANCES DECIMAL X.XXX ±0.031 X.XX ±0.063 X.X ±0.125 FRACTIONAL ± 1/8 ANGULAR ±1°			TRANS TECH <i>a TCI Company</i>		
PROPRIETARY AND CONFIDENTIAL THE INFORMATION CONTAINED IN THIS DRAWING IS THE SOLE PROPERTY OF TRANS TECH BUS. ANY REPRODUCTION IN PART OR AS A WHOLE WITHOUT THE WRITTEN PERMISSION OF TRANS TECH BUS IS PROHIBITED.					
MODEL	CJI	4/7/2014	SIZE	PART. NO.	REV
DRAWN	CJI	4/7/2014	B	-	-
APPROVED	-	-	SCALE: 1:4	-	SHEET: 1 OF 3
			PUBLISHED: -		

8 7 6 5 4 3 2 1

8

7

6

5

4

3

2

1

REVISIONS					
ZONE	REV.	DESCRIPTION	DRAWN	DATE	APPROVED

NOTES:

1) ATTACH THE ADDITIONAL LEG TO THE BASE OF THE SEAT FRAME. THE ADDITIONAL LEG SHOULD BE PLACED 5.0" ON CENTER TO THE EXISTING SEAT LEG. TWO (2) 7/16"-20 x 1-1/4" BOLTS, FOUR (4) 1/2" ID x 1-1/4" OD WASHERS AND TWO (2) 7/16"-20 NYLON LOCKING NUTS, SHOULD BE USED. TORQUE TO 55 FOOT-POUNDS.

2) DRILL ϕ .25" HOLE IN THROUGH THE FRONT SEAT FRAME. INSTALL 1/4"-20 x 1-1/2" BOLT WITH NYLON LOCKING NUT.

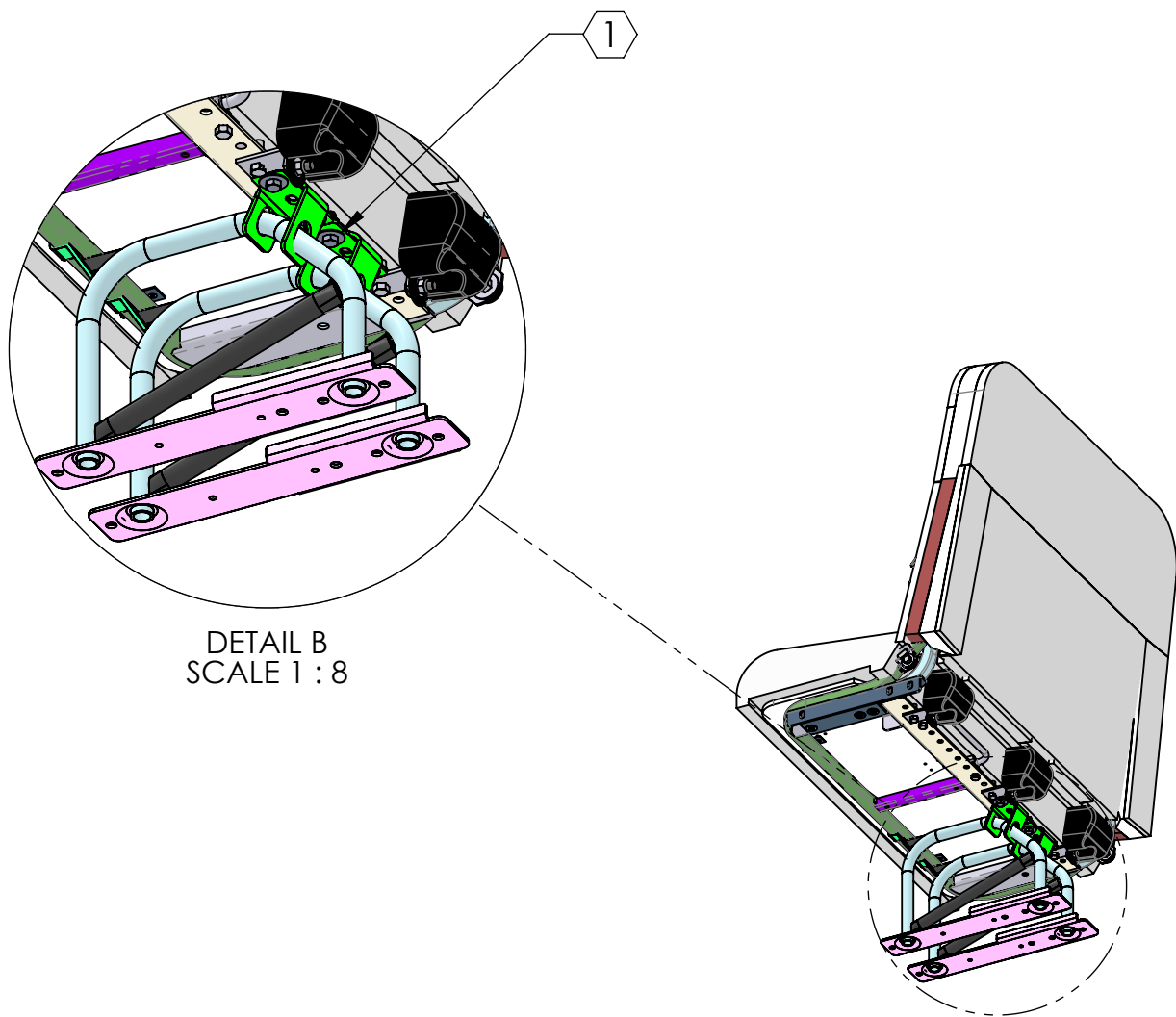

DETAIL B
SCALE 1 : 8

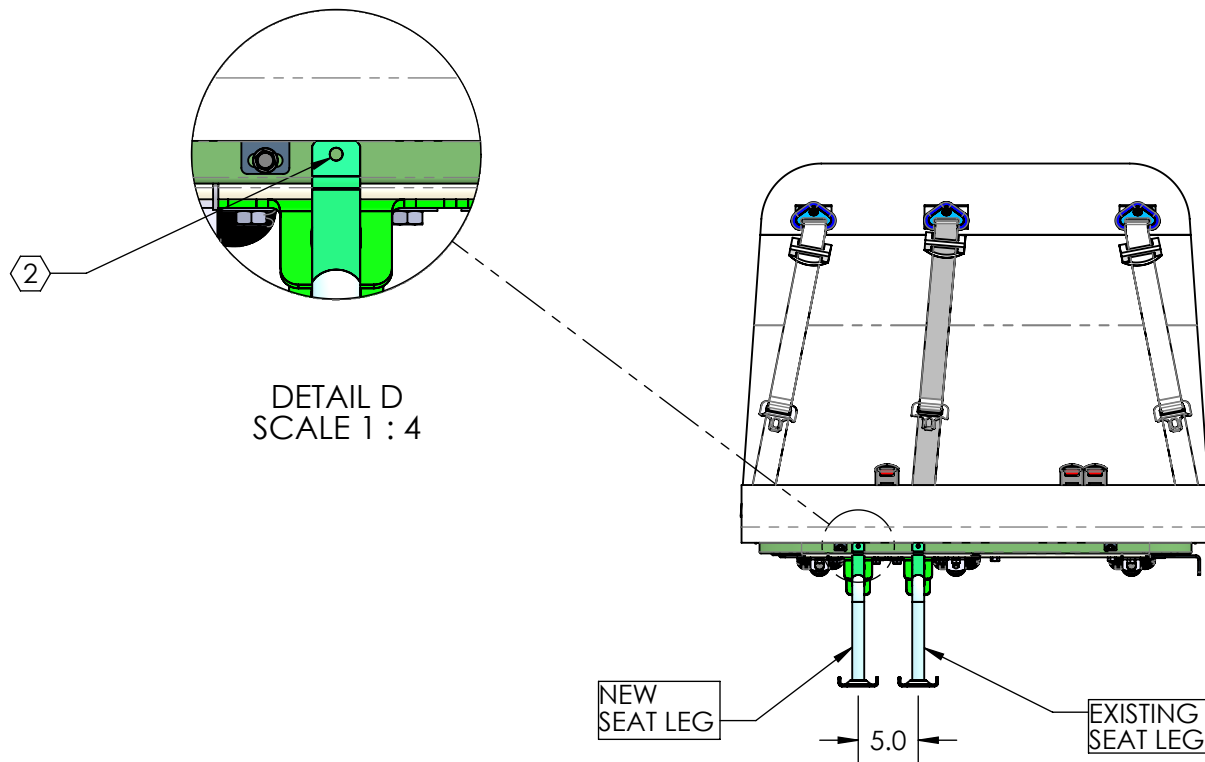

DETAIL D
SCALE 1 : 4

NEW SEAT LEG

5.0

EXISTING SEAT LEG

UNLESS OTHERWISE SPECIFIED:
 DIMENSIONS ARE IN INCHES
 TOLERANCES
 ANGULAR $\pm 1^\circ$
 DECIMAL X.XXX ± 0.031
 X.XX ± 0.063
 FRACTIONAL $\pm 1/8$

PROPRIETARY AND CONFIDENTIAL
 THE INFORMATION CONTAINED IN THIS DRAWING IS THE SOLE PROPERTY OF TRANS TECH BUS. ANY REPRODUCTION IN PART OR AS A WHOLE WITHOUT THE WRITTEN PERMISSION OF TRANS TECH BUS IS PROHIBITED.

MODEL	CJI	4/7/2014
DRAWN	CJI	4/7/2014
APPROVED	-	-

TRANS TECH
a TCI Company

TITLE:
39" QS11 3PT ADDITIONAL LEG
INSTALL

SIZE	PART. NO.	REV
B	-	-

SCALE: 1:16	-	SHEET: 2 OF 3
-------------	---	---------------

Published on: Tuesday, April 08, 2014

8

7

6

5

4

3

2

1

NOTES:

3) VERIFY THAT THE ADDITIONAL LEG IS PERPENDICULAR TO THE SURFACE OF THE FLOOR. DRILL $\phi .50"$ THROUGH THE FLOOR OF THE VEHICLE AT THE LOCATIONS ILLUSTRATED. USE CAUTION WHILE DRILLING OF CHASSIS COMPONENTS BELOW THE FLOOR.

4) INSTALL THREE (3) $7/16"-20 \times 2-1/2"$ GRADE 8 HEX BOLTS WITH $1/2"$ ID $\times 1-1/4"$ OD WASHERS ABOVE THE FLOOR. BELOW THE FLOOR, ADD A $1/2"$ ID $\times 2-1/2"$ OD FENDER WASHER AND SECURE BOLT WITH $7/16"-20$ NYLON LOCKING NUT. TORQUE TO 55 FOOT-POUNDS.

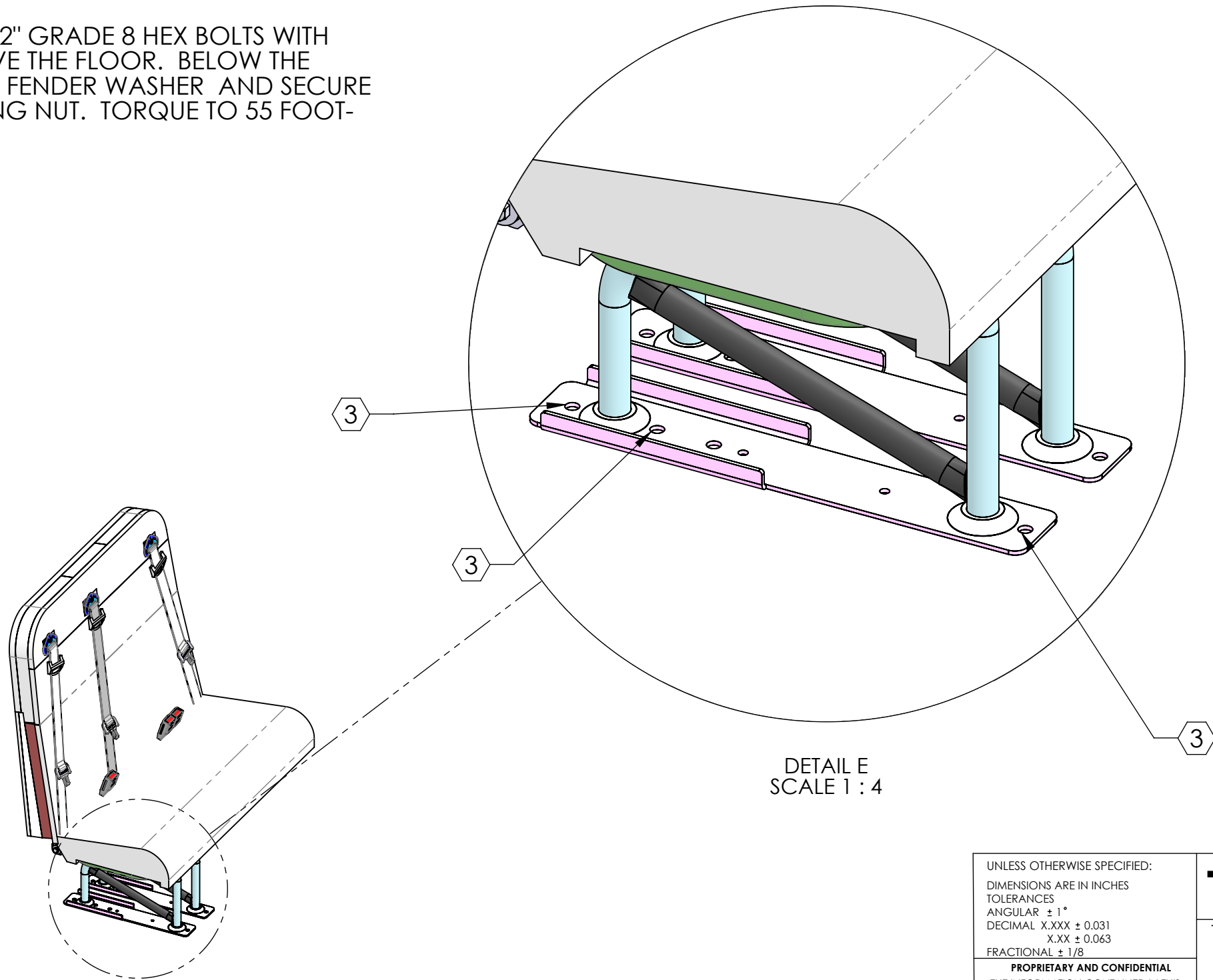

DETAIL E
SCALE 1 : 4

UNLESS OTHERWISE SPECIFIED: DIMENSIONS ARE IN INCHES TOLERANCES ANGULAR $\pm 1^\circ$ DECIMAL X.XXX ± 0.031 X.XX ± 0.063 FRACTIONAL $\pm 1/8$			TRANS TECH <i>a TCI Company</i>		
PROPRIETARY AND CONFIDENTIAL THE INFORMATION CONTAINED IN THIS DRAWING IS THE SOLE PROPERTY OF TRANS TECH BUS. ANY REPRODUCTION IN PART OR AS A WHOLE WITHOUT THE WRITTEN PERMISSION OF TRANS TECH BUS IS PROHIBITED.					
MODEL	CJI	4/7/2014	SIZE	PART. NO.	REV
DRAWN	CJI	4/7/2014	B	-	-
APPROVED	-	-	SCALE: 1:16	-	SHEET: 3 OF 3
			Published on: Tuesday, April 08, 2014		

NOTES:

- 1) MATERIAL TO BE: SEE INDIVIDUAL PARTS
- 2) FINISH TO BE: SEE INDIVIDUAL PARTS
- 3) USE ELECTRONIC STEP FILE FOR 3D GEOMETRY, AND THIS DRAWING FOR MATERIAL SPECS AND CHECK DIMENSIONS.

REVISIONS				
ZONE	REV.	DESCRIPTION	DRAWN	DATE

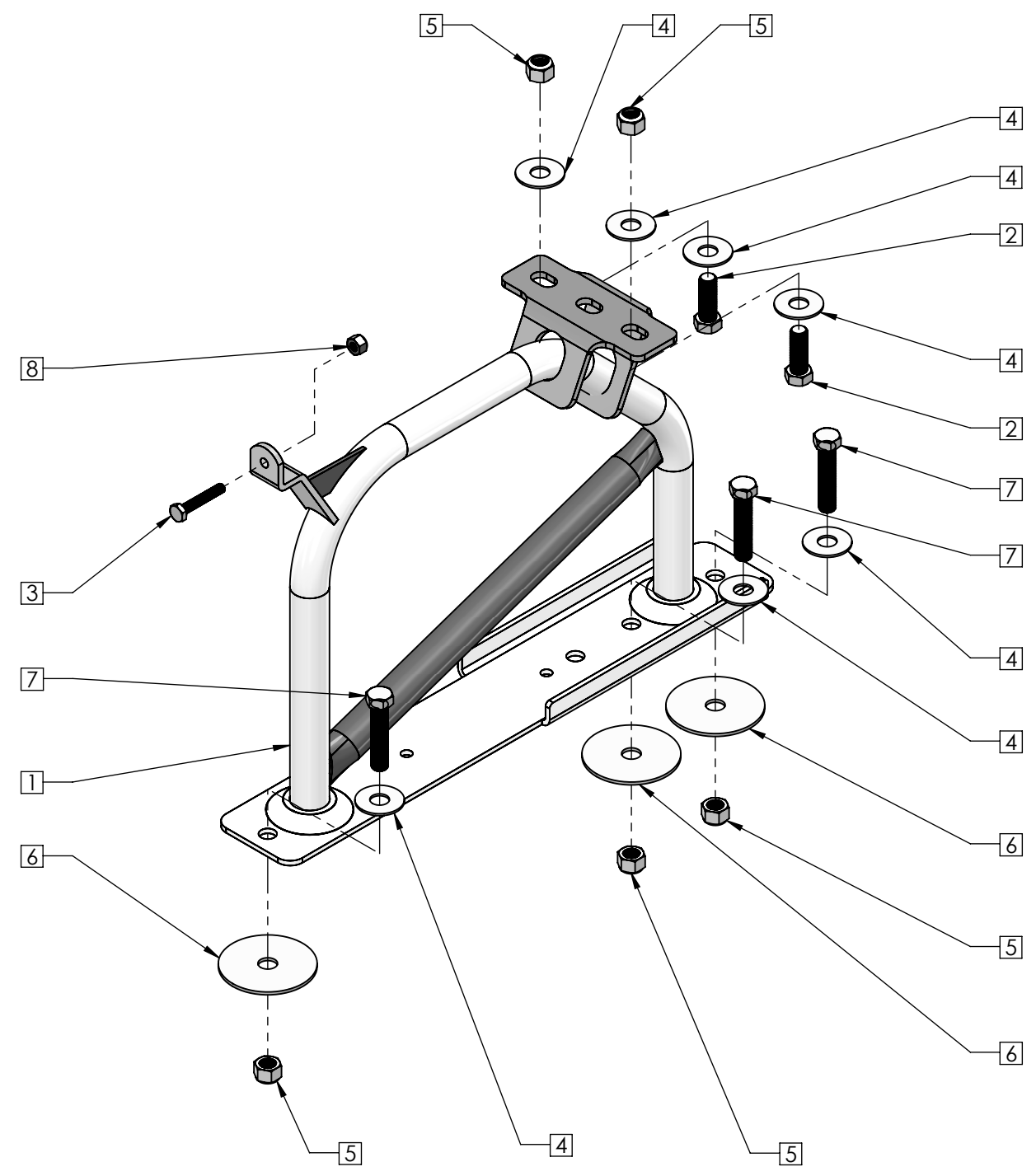

ITEM NO.	PART NUMBER	Rev	DESCRIPTION	QTY.
1	501646	-	SEAT LEG, CE WHITE	1
2	505000	-	BOLT;CAP SCREW;7/16-20x1-1/4 GRADE 8,SEAT BELT	2
3	703406	-	1/4-20x1.5" GRADE 8 HEX BOLT	1
4	589310	-	1/2" ID x 1-1/4"OD WASHER	7
5	551200	-	HEX LOCK NUT ; 7/16-20; ELASTIC; GR8 ZINC YELLOW	5
6	500760	-	WASHER, FENDER, 1/2 ID x 2-1/2 OD	3
7	703445	-	7/16"-20 x 2" GRADE 8 HEX BOLT	3
8	731955	-	1/4-20 NYLON-INSERT HEX NUT, GRADE 8, ZINC-YELLOW	1

UNLESS OTHERWISE SPECIFIED: DIMENSIONS ARE IN INCHES TOLERANCES DECIMAL X,XXX ±0.031 X,XX ±0.063 X.X ±0.125 FRACTIONAL ± 1/8 ANGULAR ±1°			<h1>TRANS TECH</h1> <p>a TCI Company</p> <p>TITLE: SEAT LEG KIT, CE WHITE 39" QS11 RECALL</p>		
<p>PROPRIETARY AND CONFIDENTIAL</p> <p>THE INFORMATION CONTAINED IN THIS DRAWING IS THE SOLE PROPERTY OF TRANS TECH BUS. ANY REPRODUCTION IN PART OR AS A WHOLE WITHOUT THE WRITTEN PERMISSION OF TRANS TECH BUS IS PROHIBITED.</p>					
MODEL	CJI	4/7/2014	SIZE	PART. NO.	REV
DRAWN	CJI	4/7/2014	B	600680	-
APPROVED	-	-	SCALE: 1:4	-	SHEET: 1 OF 1
			PUBLISHED: 4:59PM, 5/21/14		

8 7 6 5 4 3 2 1

REVISIONS					
ZONE	REV.	DESCRIPTION	DRAWN	DATE	APPROVED

NOTES:

- 1) REMOVE (2) 7/16"-20 BOLTS WITH 1/2" ID x 1-1/4" OD WASHER AND 7/16"-20 NYLON LOCKING NUT
- 2) REMOVE 7/16"-20 BOLT WITH 1/2" ID x 1-1/4" OD WASHER

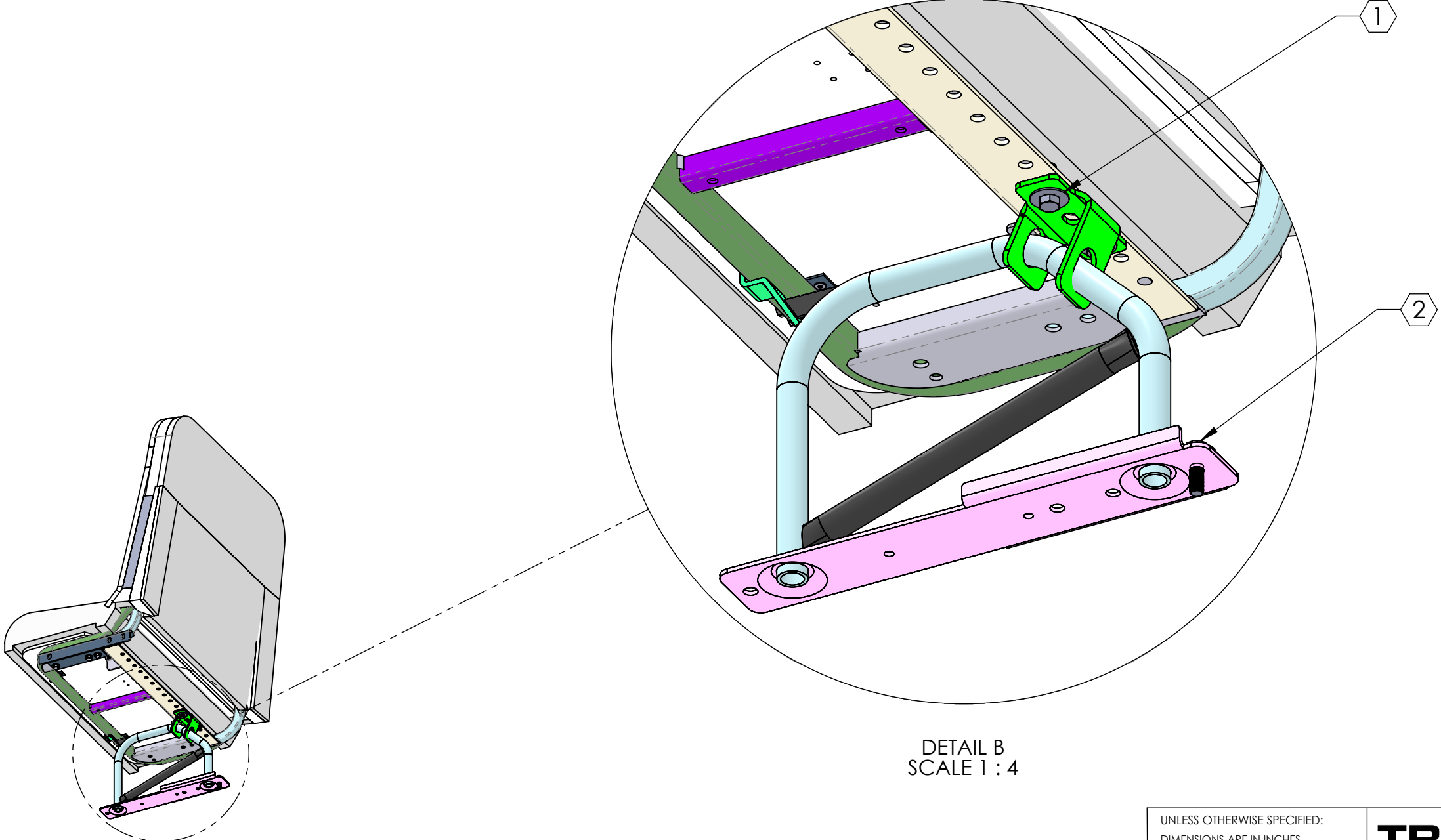

DETAIL B
SCALE 1 : 4

UNLESS OTHERWISE SPECIFIED:
 DIMENSIONS ARE IN INCHES
 TOLERANCES
 ANGULAR ± 1°
 DECIMAL X.XXX ± 0.031
 X.XX ± 0.063
 FRACTIONAL ± 1/8

PROPRIETARY AND CONFIDENTIAL
 THE INFORMATION CONTAINED IN THIS DRAWING IS THE SOLE PROPERTY OF TRANS TECH BUS. ANY REPRODUCTION IN PART OR AS A WHOLE WITHOUT THE WRITTEN PERMISSION OF TRANS TECH BUS IS PROHIBITED.

TRANS TECH
a TCI Company

TITLE:
 CE WHITE TETHER INSTALL

MODEL	CJI	4/7/2014
DRAWN	CJI	4/7/2014
APPROVED	-	-

SIZE	PART. NO.	REV
B	-	-
SCALE: 1:16	-	SHEET: 1 OF 2
Published on: Tuesday, April 08, 2014		

8 7 6 5 4 3 2 1

NOTES:

1) GENTLY LIFT SEAT FRAME AND PLACE SEAT TETHER, PART NUMBER 600670, BETWEEN SEAT LEG AND SEAT FRAME.

2) REINSTALL (2) 7/16"-20 BOLTS WITH NUTS AND 1/2" ID x 1-1/4" OD WASHERS. TORQUE BOLTS TO 55 FOOT-POUNDS.

3) REPLACE EXISTING BOLT WITH 7/16"-20 x 1-1/2 BOLT, REUSING 1/2" ID x 1-1/4" OD WASHER. TORQUE BOLT TO 55 FOOT-POUNDS.

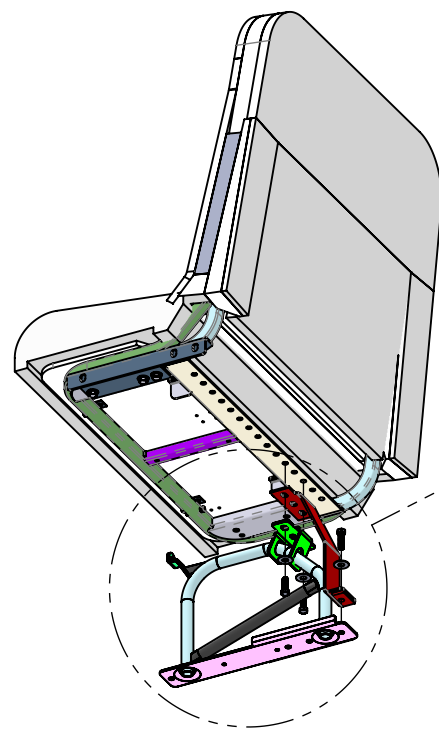

EXPLODED VIEW

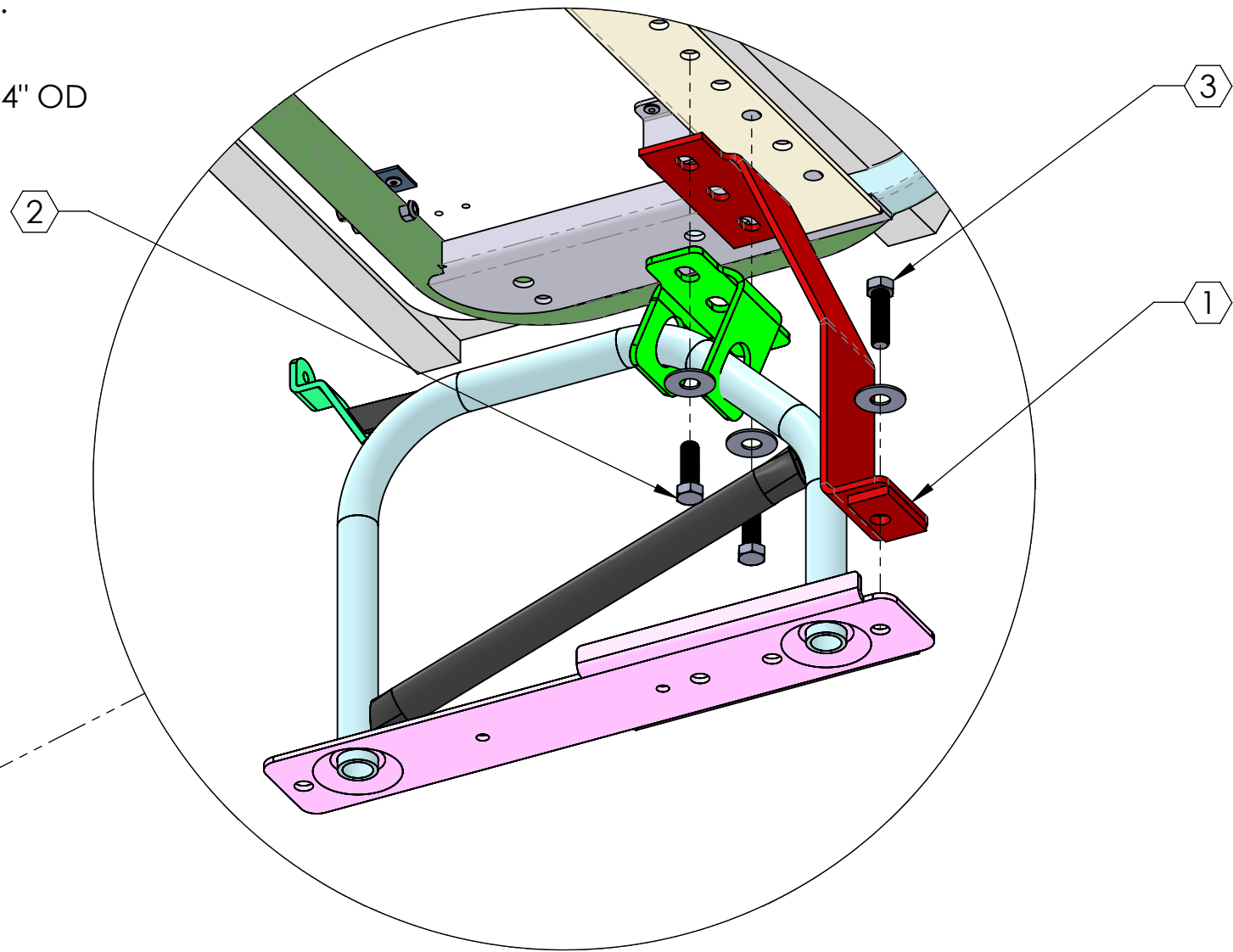

DETAIL C
SCALE 1 : 4

UNLESS OTHERWISE SPECIFIED: DIMENSIONS ARE IN INCHES TOLERANCES DECIMAL X,XXX ±0.031 X,XX ±0.063 X,X ±0.125 FRACTIONAL ± 1/8 ANGULAR ±1°			TRANS TECH <i>a TCI Company</i>		
PROPRIETARY AND CONFIDENTIAL THE INFORMATION CONTAINED IN THIS DRAWING IS THE SOLE PROPERTY OF TRANS TECH BUS. ANY REPRODUCTION IN PART OR AS A WHOLE WITHOUT THE WRITTEN PERMISSION OF TRANS TECH BUS IS PROHIBITED.					
MODEL	CJI	4/7/2014	SIZE	PART. NO.	REV
DRAWN	CJI	4/7/2014	B	-	-
APPROVED	-	-	SCALE: 1:16	-	SHEET: 2 OF 2
			PUBLISHED: 4/8/2014		