

January 15, 2016

03086 Version 4

Safety Recall: Odyssey Fuel PumpSupersedes 14-032, dated July 25, 2014, to revise the information highlighted in **yellow**.**AFFECTED VEHICLES**

Year	Model	Trim	VIN Range
2005-10	Odyssey	ALL	Check the iN VIN status for eligibility

REVISION SUMMARY

Under REPAIR PROCEDURE, a step to include the Vehicle Emissions Recall – Proof of Correction certificate was added.

BACKGROUND

Over time, the fuel filter assembly may be exposed to certain external conditions that may cause customers to notice a fuel smell.

NOTE: Vehicles that were repaired under Service Bulletin 14-015, *Safety Recall: Odyssey Fuel Smell or Leak*, must still be repaired under this bulletin to make sure the improved fuel filter set is installed.

CORRECTIVE ACTION

Replace the fuel filter set with the improved parts set.

CUSTOMER NOTIFICATION

Owners of affected vehicles will be sent a notification of this campaign beginning in June 2014.

Do an iN VIN status inquiry to make sure the vehicle is shown as eligible.

Some vehicles affected by this campaign may be in your used vehicle inventory. These vehicles must be repaired before they are sold.

Should a dealership sell an unrepaired vehicle that subsequently causes an injury or damage because of the recalled item, the dealership will be solely responsible to the damaged party, and will be required to defend and indemnify American Honda for any resulting claims. To see if a vehicle in inventory is affected by this campaign, do a VIN status inquiry before selling it.

TOOL INFORMATION

Tool Name	Tool Number	Quantity
Fuel Sender Wrench	07AAA-S0XA100	1

PARTS INFORMATION

Part Name	Part Number	Quantity
Fuel Filter Set (includes fuel filter set, subharness, retainer, three O-rings, backup ring, clip, locknut, and base gasket)	06177-SHJ-305	1

NOTE: For dealers experiencing a strong fuel smell from storing the fuel pump sets replaced under this Service Bulletin, these fuel sets may be disposed of immediately in accordance with local regulations. This only applies to the fuel filter set replaced under this Service Bulletin. The published retention policy remains in effect for all other parts. If you have any questions to this exception or other parts retention issues please contact the WPI Administrative Office at 937-642-2737.

WARRANTY CLAIM INFORMATION

Operation Number	Description	Flat Rate Time	Template ID	Failed Part Number
1191A8	Replace the fuel filter set.	0.8 hr.	14-032A	17048-SHJ-A00

Defect Code: 5KY00

Symptom Code: JE000

Skill Level: Repair Technician

REPAIR PROCEDURE

NOTE: Make sure this repair is done in a well ventilated area.

1. Remove the second row seats.
2. Fold down the third row seats.
3. Remove the screws (11) and detach the clip (1), then remove the second row seat striker covers and the second row seat hook covers.

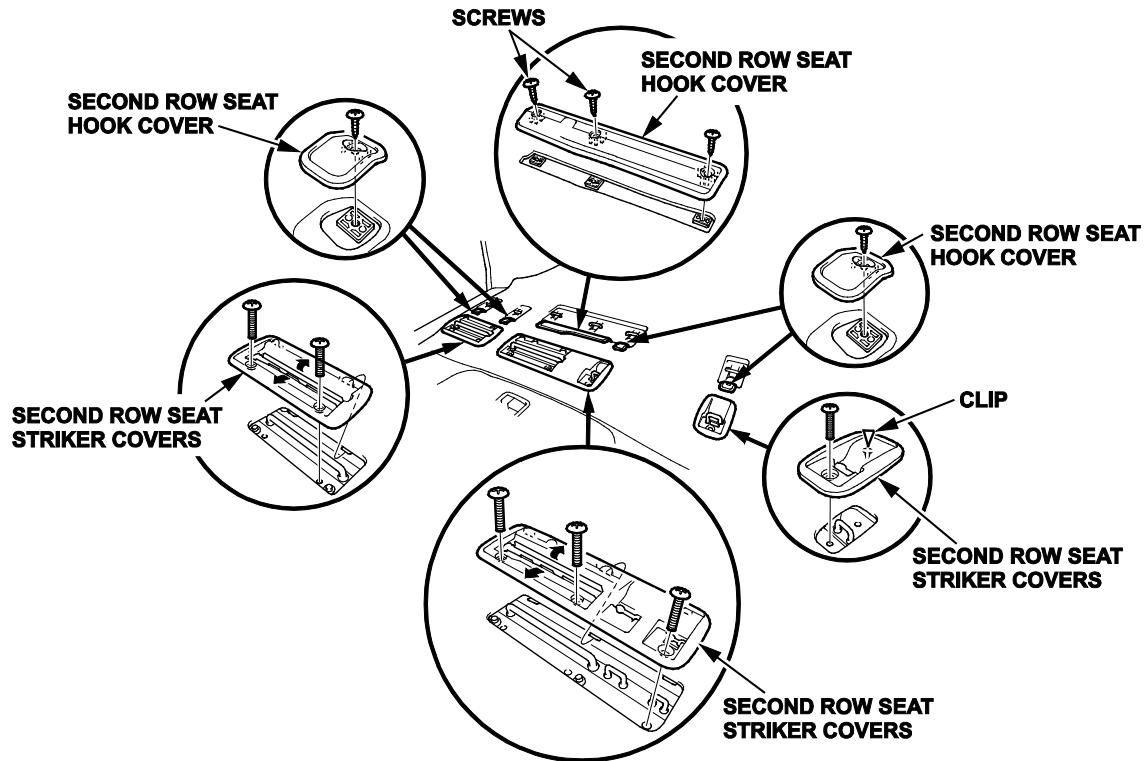

- Pull up the rear carpet to release the hook and loop fasteners and detach the clips. Continue pulling back the carpet to reach the fuel pump access panel and the fuel tank unit.

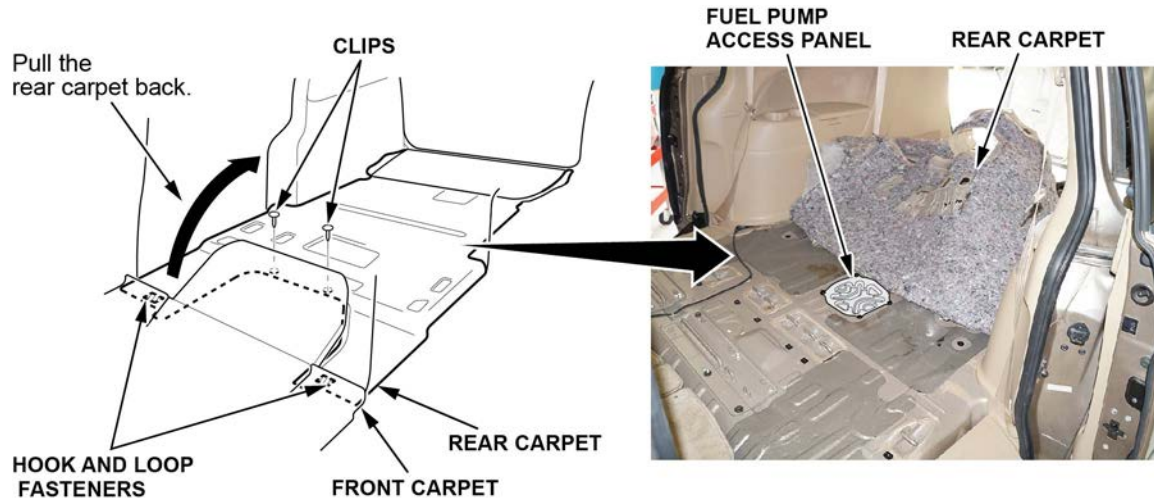

- Remove the access panel from the floor.
'05-07 MODELS

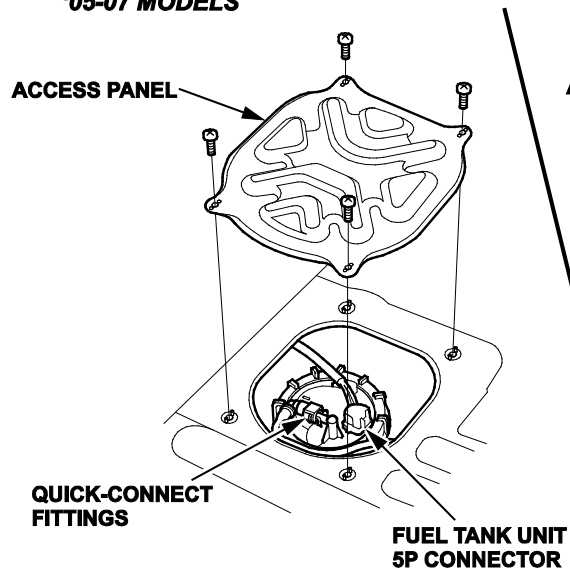

'08-10 MODELS

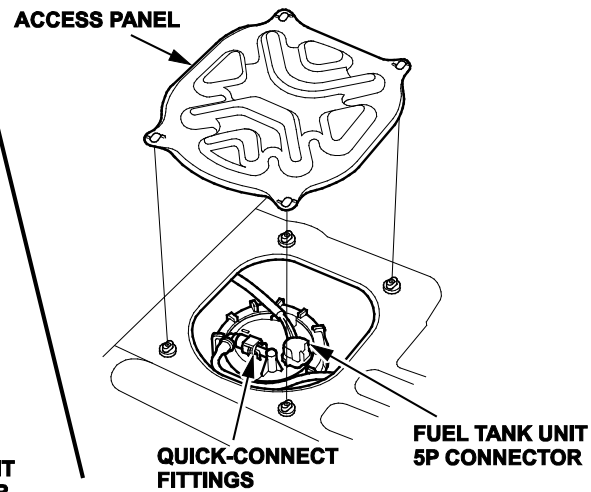

- Relieve the fuel pressure.
- Remove the fuel cap.
- Disconnect the fuel tank unit 5P connector.
- Disconnect the quick-connect fitting from the fuel tank unit.

10. Using the special tool, loosen the locknut, then remove the locknut and the fuel tank unit.

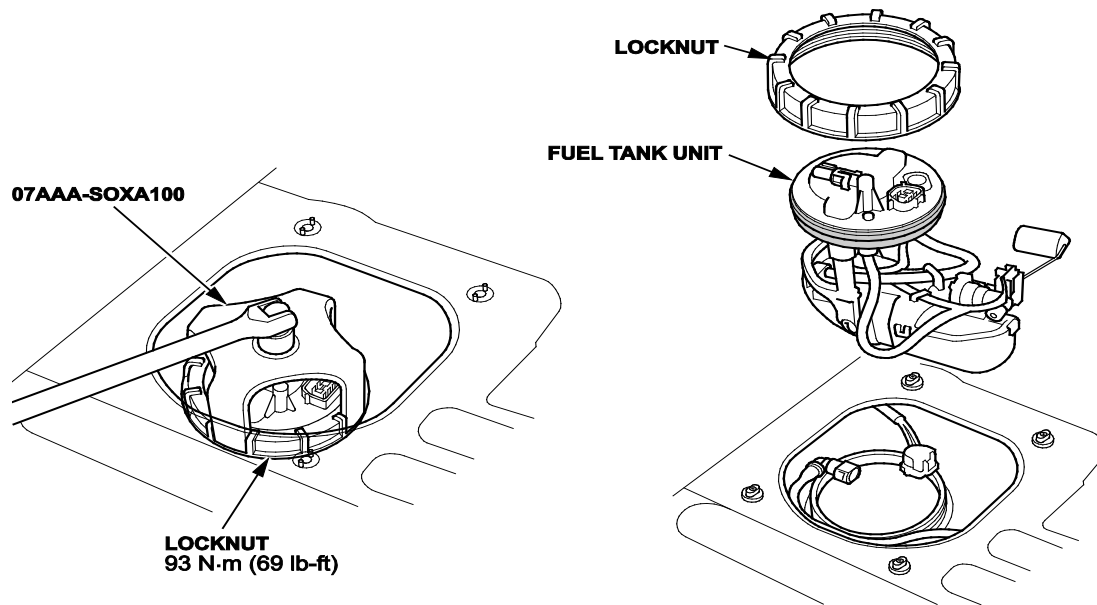

11. Remove the fuel pressure regulator from the fuel pump housing.

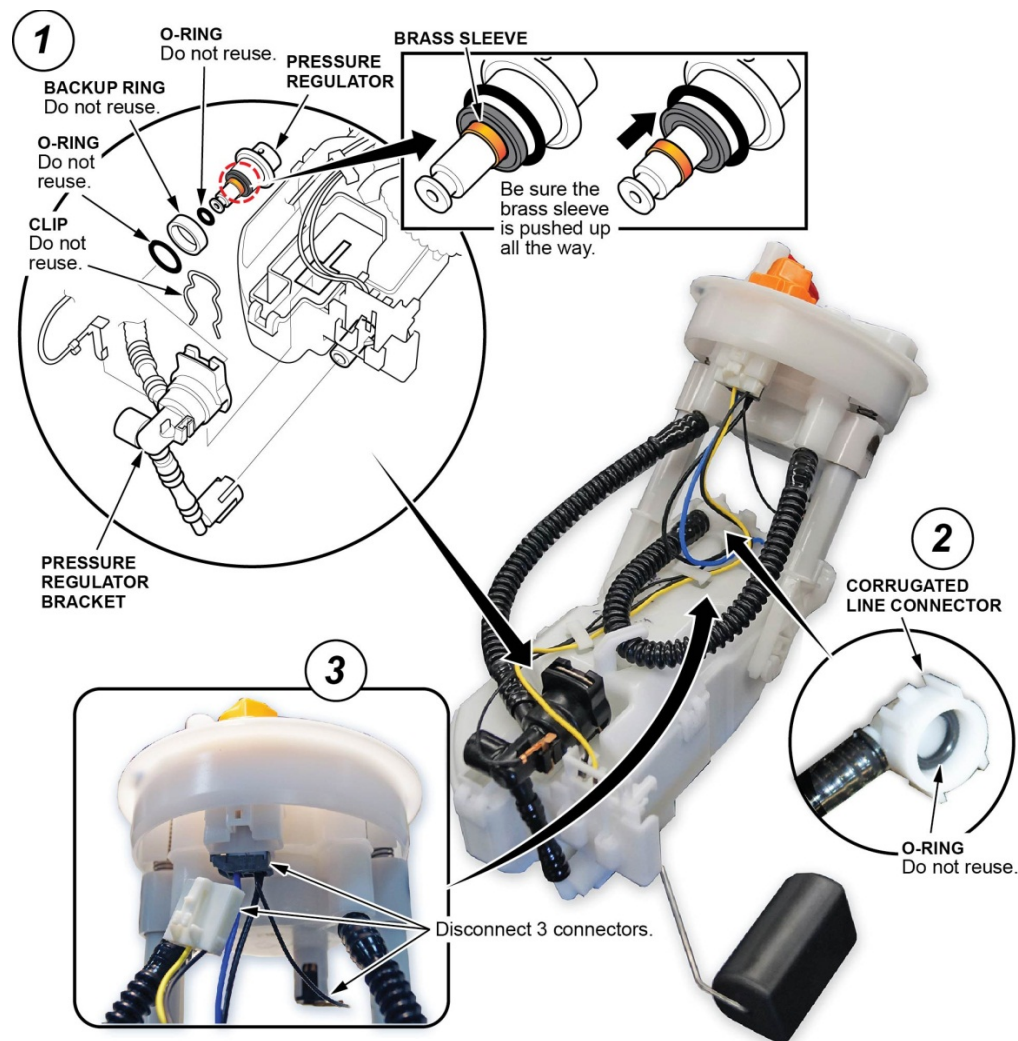

12. Remove the corrugated line connector from the fuel pump housing.
13. Disconnect the three wire harness connectors from the fuel filter set.
14. Remove the original fuel filter set from the fuel pump housing.



15. Remove the 2P wire subharness connector from the fuel pump housing.

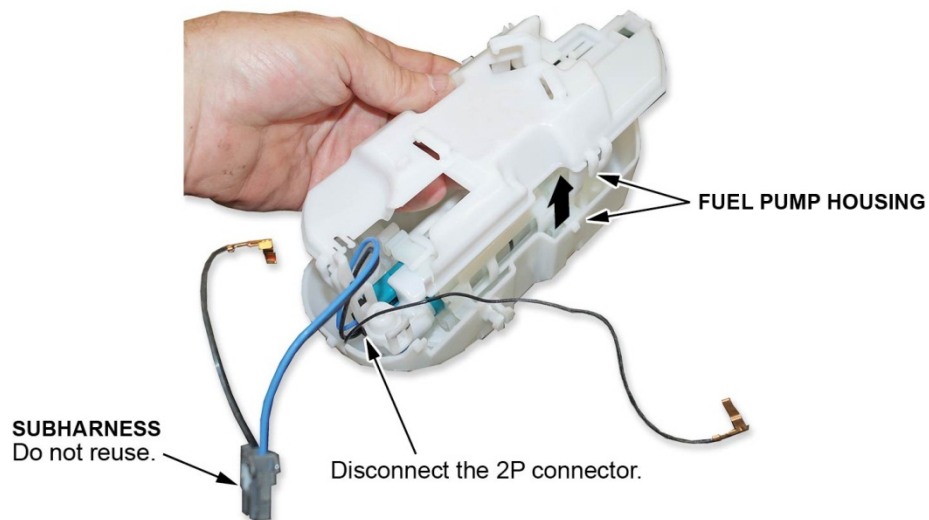

16. Install the new 2P wire connector to the fuel pump housing.
17. Reinstall the fuel pressure regulator with new O-rings, plastic spacer (backup ring), and clip. Lightly coat the new O-rings with clean engine oil.
18. Install the new fuel filter set to the fuel pump housing and reconnect all connectors.
19. Temporarily attach a new base gasket to the fuel tank unit, then insert the fuel tank unit partially into the fuel tank.

20. Transfer the base gasket from the fuel tank unit to the fuel tank.

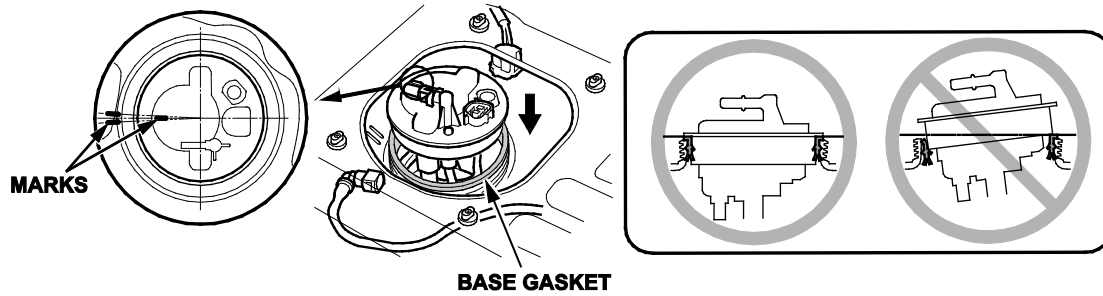

21. Align the marks on the tank and the fuel tank unit, then insert the fuel tank unit into the fuel tank until it rests on the base gasket.

NOTE: To avoid a fuel leak, check the base gasket visually or by hand to make sure it is not pinched.

22. Using the special tool, tighten the new locknut to **93 N·m (69 lb-ft)**.

NOTE:

- After tightening, make sure the marks are still aligned.
- After installation, check the base gasket visually or by hand to make sure it is not pinched.

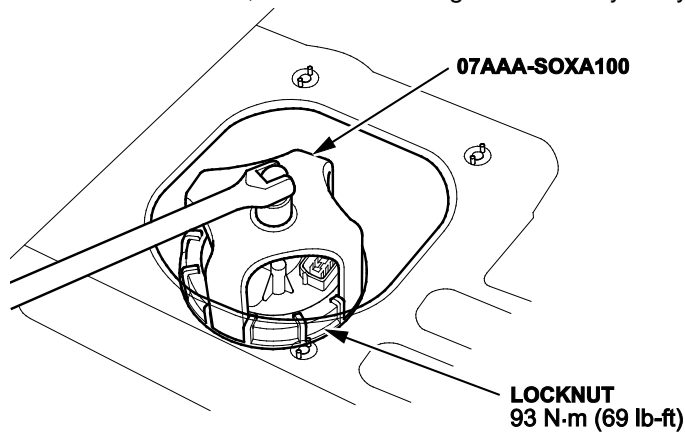

23. Insert the new retainer in the quick-connect fitting, then connect it to the fuel pump.

24. Connect the fuel tank unit 5P connector.

25. Turn the ignition switch to ON (II) (but do not start the engine). The fuel pump runs for about 2 seconds, and fuel pressure rises. Repeat this two or three times, then make sure there are no fuel leaks.

26. Install the access panel.

27. Install the carpet, the hook covers, the striker covers, and the second row seats.

NOTE: Take care not to damage, wrinkle or twist the carpet. If the clips are damaged or stress-whitened, replace them with new ones. Push the clips into place securely.

28. Install the fuel fill cap.

29. **For California residents only:** Fill out a Vehicle Emissions Recall – Proof of Correction certificate, and use **JEO** as the recall number. Give the certificate to your customer, and advise him or her to keep it as proof that the product update was completed. Your customer will need to submit this certificate to the DMV only if the DMV requests it. If you need more certificates, use reorder number Y0657.

The image shows a 'Vehicle Emission Recall - Proof of Correction' form. The form has a header with the title. Below the header are fields for License Number, Make, Year Model, Body Type, and Vehicle Identification Number. The Recall Number field is circled in black and contains the text 'JEO'. Below these fields is a section for the Manufacturer and a statement: 'The above described vehicle has been repaired, modified and/or equipped with new emission control devices to meet applicable California Emission Control Laws.' There are also fields for Dealer's Name, Address, City, State and Zip, Date, and Dealership's Authorized Signature. At the bottom, there is a note: 'Return this certificate to DMV only when required - otherwise retain for your records.' The form number Y0657 is in the bottom left corner and ACL 24832 (0212) is in the bottom right corner.

END

CUSTOMER INFORMATION: The information in this bulletin is intended for use only by skilled technicians who have the proper tools, equipment, and training to correctly and safely maintain your vehicle. These procedures should not be attempted by "do-it-yourselfers," and you should not assume this bulletin applies to your vehicle, or that your vehicle has the condition described. To determine whether this information applies, contact an authorized Honda automobile dealer.