

March 13, 2014

ATB 51165 (1403)

Safety Recall: Odyssey Fuel Smell or Leak

AFFECTED VEHICLES

Year	Model	Trim	VIN Range
2005-10	Odyssey	ALL	Check the iN VIN status for eligibility

BACKGROUND

Over time, the fuel filter assembly may be exposed to certain external condition that may cause customers to notice a fuel smell.

This campaign will have two phases. During the first phase, customers will be notified of the recall. If a customer comes in and either complains of a fuel smell, fuel leak or requests an inspection, refer to the inspection and repair procedure in this bulletin. Otherwise, customers should wait until the second phase of the recall.

For the second phase, all vehicles identified in the VIN status inquiry will receive improved parts, including those that previously had the fuel filter set replaced with original parts.

CORRECTIVE ACTION

Inspect the fuel filter set for cracks, leaks, or a fuel smell, and if necessary, replace the fuel filter set with the pre-counter measure fuel filter set.

CUSTOMER NOTIFICATION

Owners of affected vehicles will be sent a notification of this campaign in spring 2014.

Do an iN VIN status inquiry to make sure the vehicle is shown as eligible.

Some vehicles affected by this campaign may be in your used vehicle inventory. These vehicles must be inspected, and if necessary, repaired before they are sold.

Should a dealership sell an unrepaired vehicle that subsequently causes an injury or damage because of the recalled item, the dealership will be solely responsible to the damaged party, and will be required to defend and indemnify American Honda for any resulting claims. To see if a vehicle in inventory is affected by this campaign, do a VIN status inquiry before selling it.

TOOL INFORMATION

Fuel Sender Wrench: T/N 07AAA-SOXA100

REQUIRED MATERIALS

Developer: Commercially available

PARTS INFORMATION

Part Name	Part Number	Quantity
Fuel Filter Set	17048-SHJ-A00	1
Retainer	17711-S0X-003	1

WARRANTY CLAIM INFORMATION

FOR INSPECTION ONLY

Operation Number	Description	Flat Rate Time	Template ID	Failed Part Number
1115A4	Inspect the fuel filter set for cracks, fuel leaks, or a fuel smell.	0.6 hour	14-015A	17048-SHJ-A00

FOR INSPECTION AND REPLACEMENT

Operation Number	Description	Flat Rate Time	Template ID	Failed Part Number
1115A4	Inspect the fuel filter set for cracks, fuel leaks, or a fuel smell.	0.6 hour	14-015B	17048-SHJ-A00
A	Replace the fuel filter set add.	0.2 hour		

Defect Code: 5KY00

Symptom Code: JD900

Skill Level: Repair Technician

INSPECTION AND REPAIR PROCEDURE

1. Remove the second row seats.
2. Pull back the carpet to reach the fuel pump access panel and the fuel tank unit.
3. Remove the access panel from the floor.

'05-07 MODELS

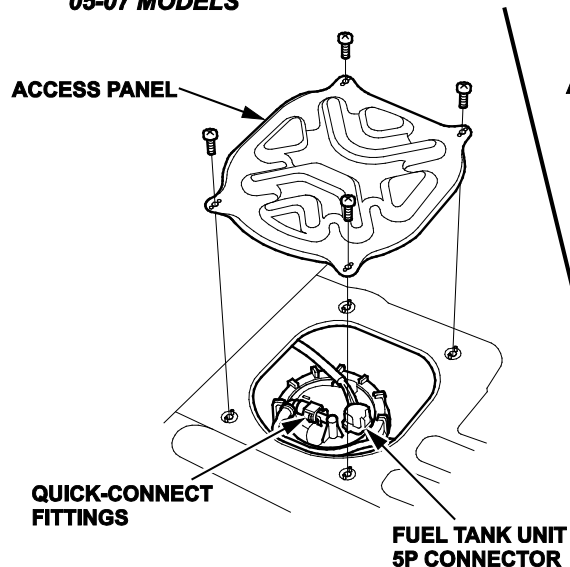

'08-10 MODELS

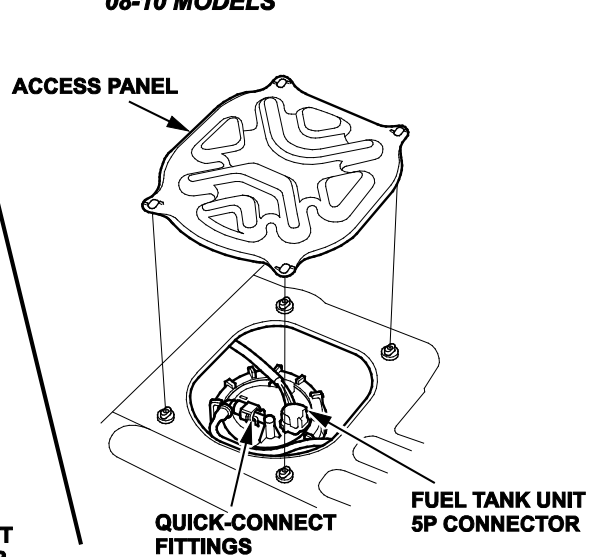

4. Wipe the flange surface with a clean shop towel. Start the engine to pressurize the system, then check it for cracks, fuel leaks, or a fuel smell.
 - If you find no cracks, fuel leaks, or fuel smell, **DO NOT** replace the fuel filter set at this time. Reinstall all removed parts.
 - If you smell fuel, go to step 6 to replace the fuel filter set.
 - If you find a crack but there is no visible fuel leak or, fuel smell, go to step 5
5. Apply developer on the top surface of the flange. Let the developer dry for 10 minutes. Start the engine to pressurize the system.



- If no fuel leak is found, **DO NOT** replace the fuel filter set. Wipe off the developer, then reinstall all removed parts.
- If a fuel leak is found, go to step 6 to replace the fuel filter set.

6. Relieve the fuel pressure.
7. Remove the fuel cap.
8. Disconnect the fuel tank unit 5P connector.
9. Disconnect the quick-connect fitting from the fuel tank unit.
10. Using the special tool, loosen the locknut, then remove the locknut and the fuel tank unit.

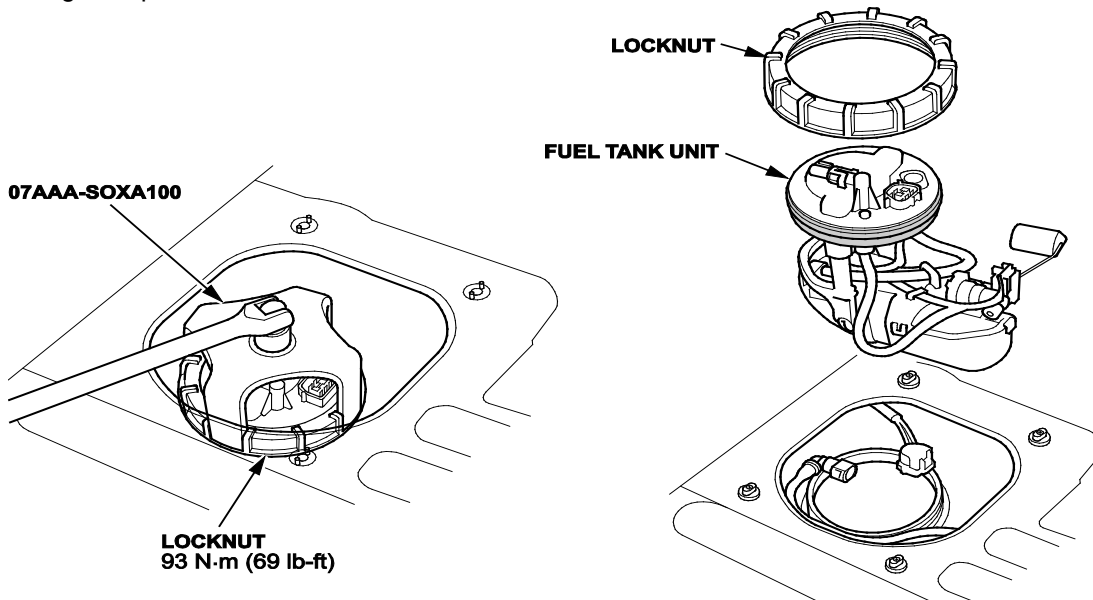

11. Remove the fuel pressure regulator from the fuel pump housing.

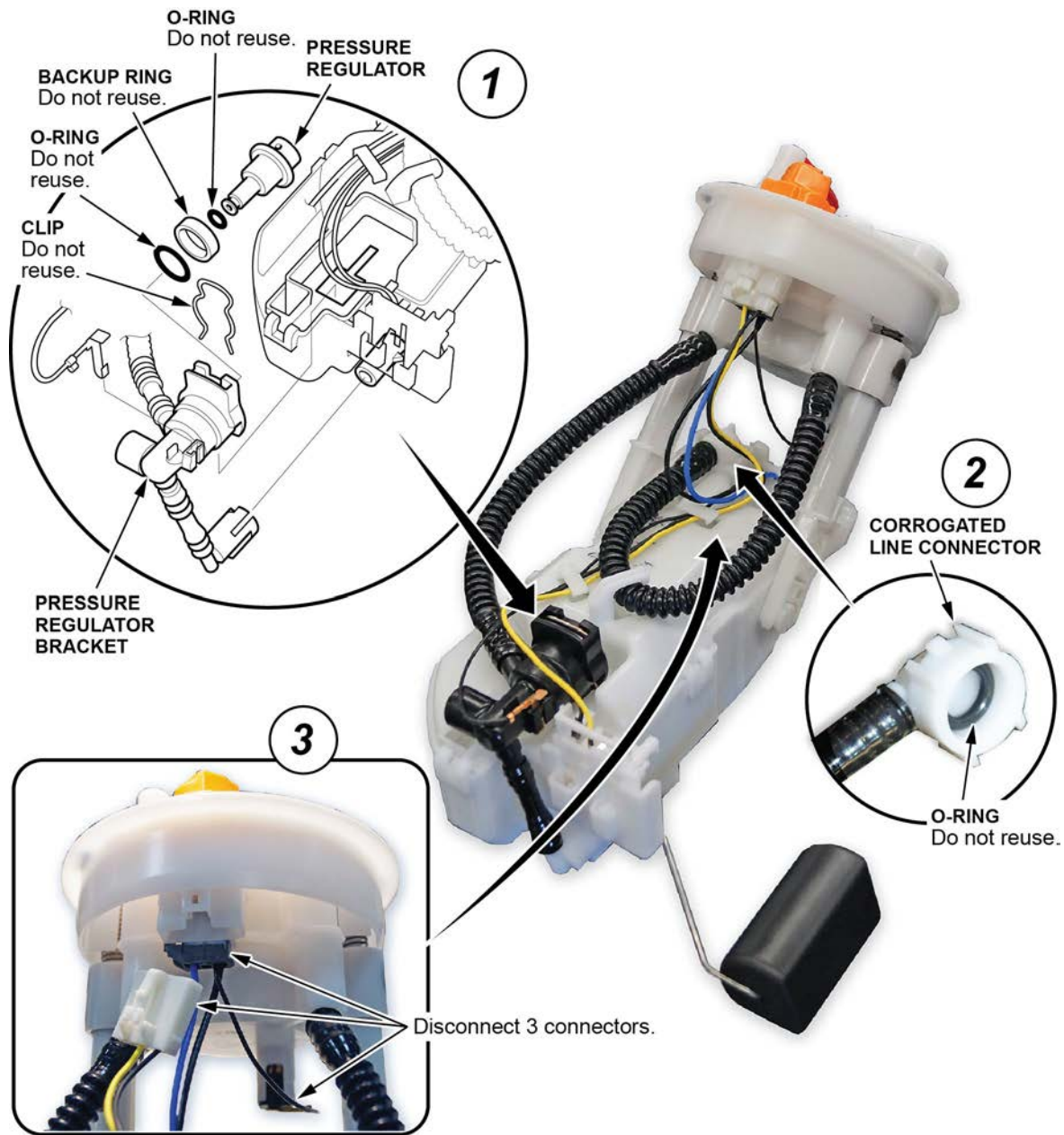

12. Remove the corrugated line connector from the fuel pump housing.

13. Remove the three wire harness connectors from the fuel filter set.

14. Remove the original fuel filter set from the fuel pump housing.



15. Remove the 2P wire sub harness connector from the fuel pump housing.

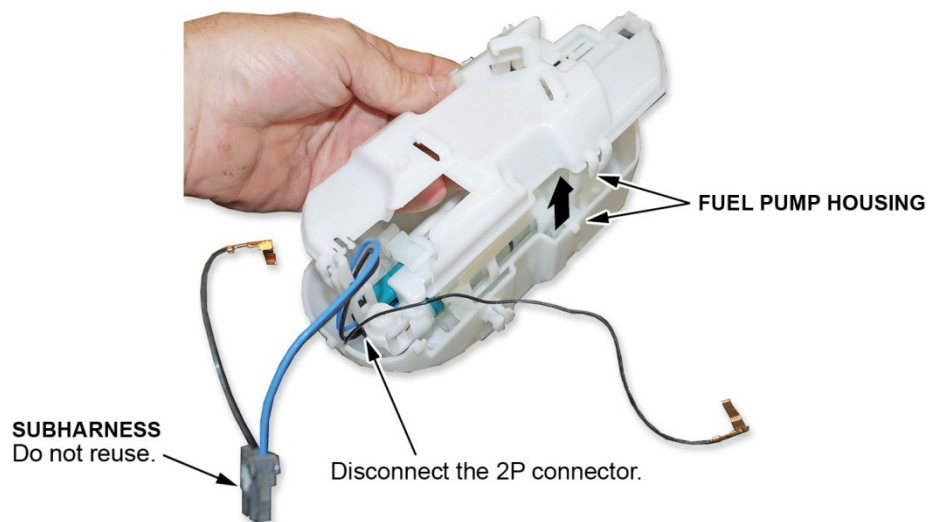

16. Reinstall the new 2P wire connector to the fuel pump housing.

17. Reinstall the fuel pressure regulator with new O-rings, plastic spacer, and clip. Lightly coat the new O-rings with clean engine oil.

18. Install the fuel filter set to the fuel pump housing and reconnect all connectors.

19. Temporarily attach a new base gasket to the fuel tank unit, then insert the fuel tank unit partially into the fuel tank.

20. Transfer the base gasket from the fuel tank unit to the fuel tank.

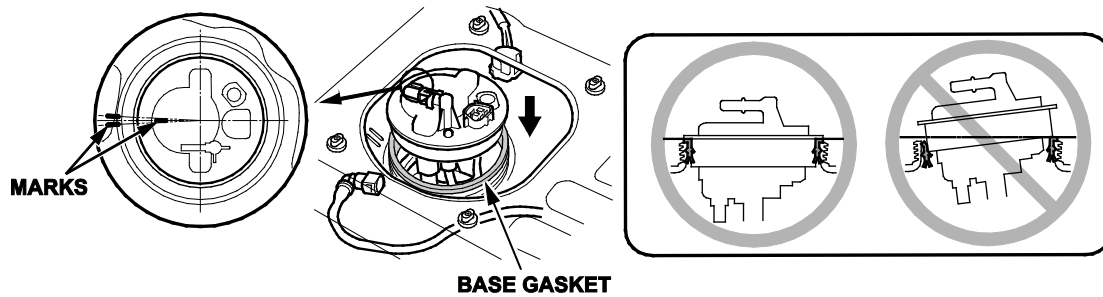

21. Align the marks on the tank and the fuel tank unit, then insert the fuel tank unit into the fuel tank until it rests on the base gasket.

NOTE: To avoid a fuel leak, check the base gasket visually or by hand to make sure it is not pinched.

22. Using the special tool, tighten the new locknut to **93 N·m (69 lb-ft)**.

NOTE:

- After tightening, make sure the marks are still aligned.
- After installation, check the base gasket visually or by hand to make sure it is not pinched.

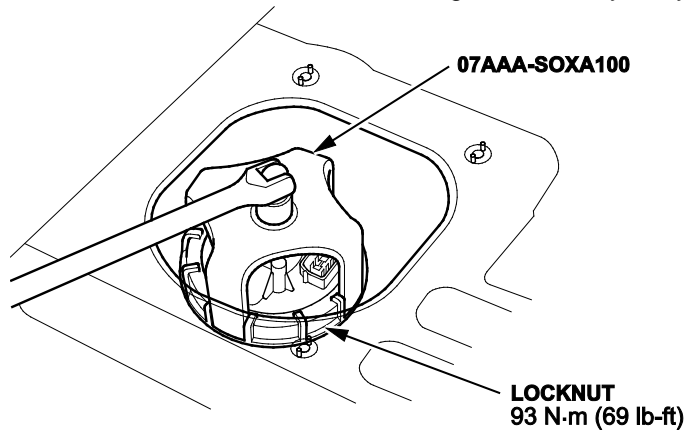

23. Insert the new retainer in the quick-connect fitting, then connect it to the fuel pump.

24. Connect the fuel tank unit 5P connector.

25. Turn the ignition switch to ON (II) (but do not start the engine). The fuel pump runs for about 2 seconds, and fuel pressure rises. Repeat this two or three times, then make sure there are no fuel leaks.

26. Wipe off any remaining developer from the tank and connectors.

27. Install the access panel.

28. Install the carpet and the second row seats.

29. Install the fuel fill cap.

CUSTOMER INFORMATION: The information in this bulletin is intended for use only by skilled technicians who have the proper tools, equipment, and training to correctly and safely maintain your vehicle. These procedures should not be attempted by "do-it-yourselfers," and you should not assume this bulletin applies to your vehicle, or that your vehicle has the condition described. To determine whether this information applies, contact an authorized Honda automobile dealer.