

April 2014

FL659A-C

NHTSA # 14V-075 (Non-Schools Buses)

NHTSA # 14V-074 (School Buses)

## Work Instructions

### Subject: TBB Minotour Rear Floor Reinforcement

**Models Affected:** Specific Thomas Built Buses Minotour DRW school buses manufactured October 21, 2011, through January 16, 2014.

#### Repair Procedure

1. Chock wheels, shift into Neutral or Park. Set parking brake.
2. Remove any fasteners located at the area where reinforcements will be installed, such as seat bolts.
3. Position the reinforcement with the bend side down in the location shown in the installation diagram below that matches the bus. (See **Figure 1** below and diagrams at the end of these Work Instructions.)
4. Mark the location of each hole using a white grease pencil. Move the reinforcement to next the location and repeat.
5. Drill eight (8) 3/8" holes in the front side of the last joist and the back side of the second to last joist so that the reinforcements can be installed in the proper location. **Note: Each set of two holes must be drilled all the way through each joist. Figure 1**

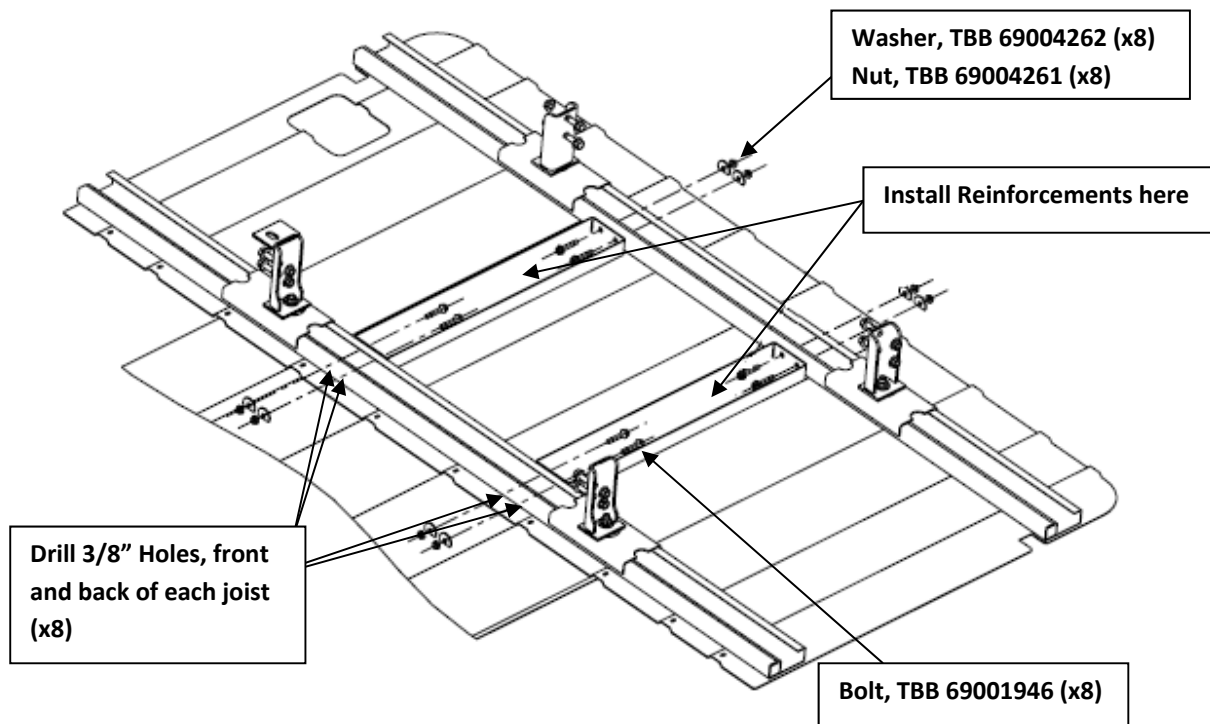

Figure 1

# Recall Campaign

Daimler Trucks  
North America LLC

April 2014

FL659A-C

NHTSA # 14V-075 (Non-Schools Buses)

NHTSA # 14V-074 (School Buses)

6. Mount reinforcement TBB 185459 or TBB 186111 to the floor joists using bolt TBB 69001946, washer TBB 69004262, and nut TBB 69004261.
7. If any seat fasteners were located in this area, re-drill fastener holes from inside the bus through the reinforcement.
8. Reinstall seat fasteners through the reinforcement. Torque to 14 ft.-lbs.
9. Apply undercoating.
10. Unchock the wheels; place back into service.

## Seating Configurations

To determine your seating configuration, review the plans below.

### Installation A: GM 041, IMMI/S3C Seats

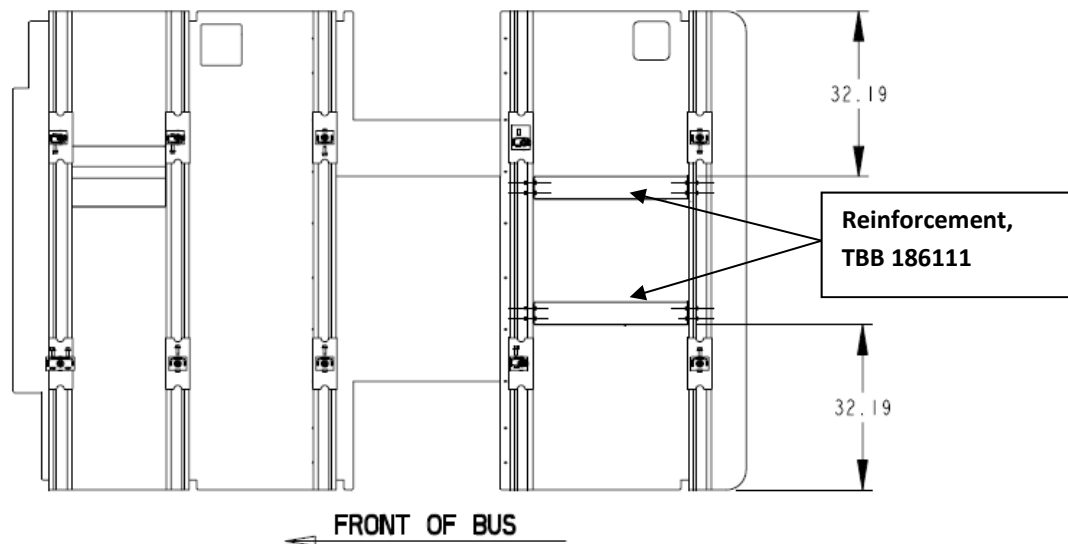

# Recall Campaign

April 2014  
FL659A-C  
NHTSA # 14V-075 (Non-Schools Buses)  
NHTSA # 14V-074 (School Buses)

## Installation B1: GM 051, IMMI/S3C Seats

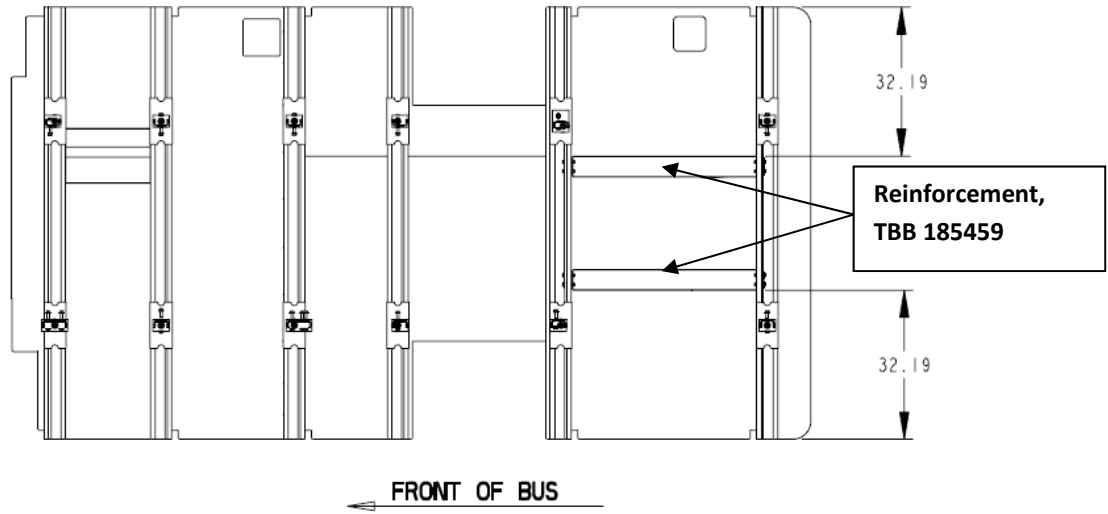

## Installation B2: GM 051, IMMI/S3C Seats

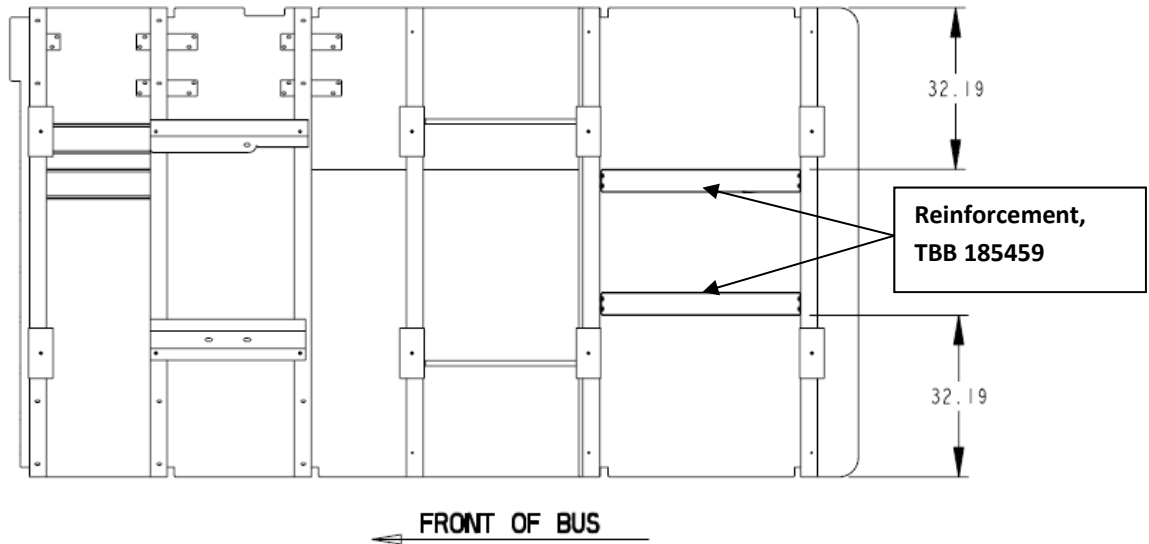

# Recall Campaign

April 2014  
FL659A-C  
NHTSA # 14V-075 (Non-Schools Buses)  
NHTSA # 14V-074 (School Buses)

Installation C1: GM 051, Lift

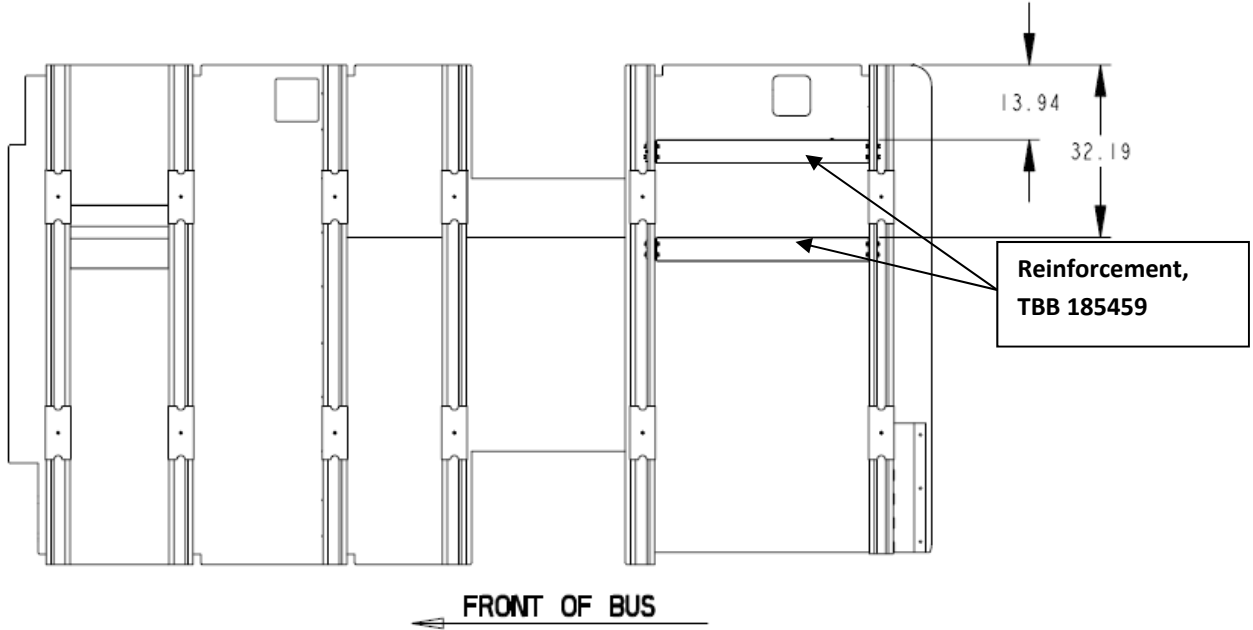

Installation C2: GM 051 FF, Lift

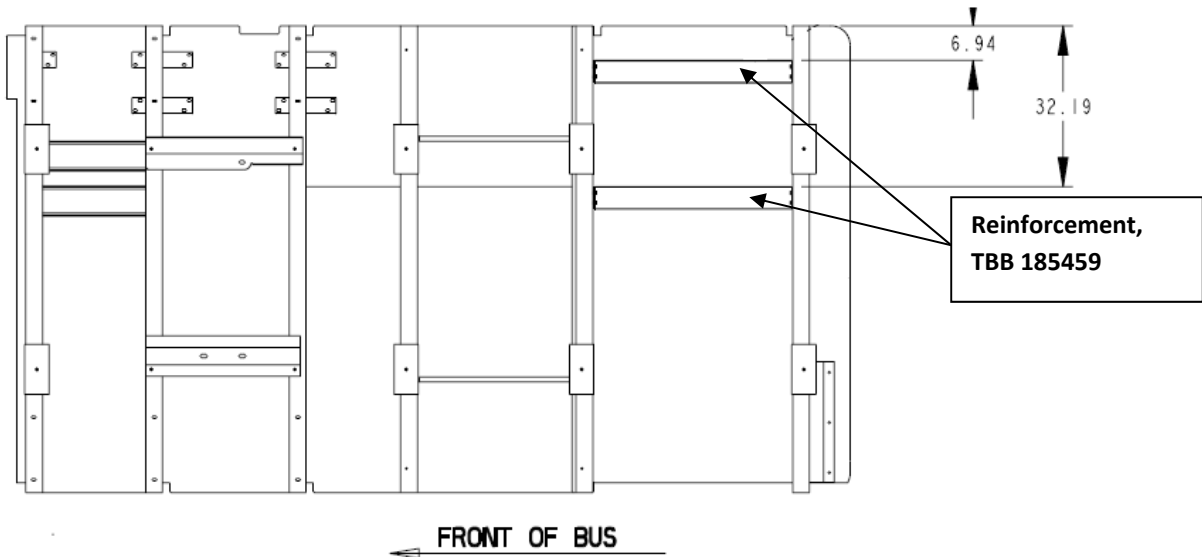

# Recall Campaign

April 2014

FL659A-C

NHTSA # 14V-075 (Non-Schools Buses)

NHTSA # 14V-074 (School Buses)

## Tools

Socket Set or Air Ratchet

3/8" drill bit

Drill

White Grease Pencil