

QUARANTINE NOTICE		
To:	All North America Dealers	Reference QN-03-0019 Issued: 17 January 2014
For the attention of:	Service Manager/After Sales Manager	
Please copy to:	Dealer Principal Sales Manager Warranty Administrator Aston Martin Technician(s) Parts Manager	
Model:	All Models Manufactured from 11 November 2007 until 31 December 2013 but not New Vanquish or Cygnet	
VIN Range:	Refer to the separately published list of VINs	Page 1 of 11
Subject:	Throttle Pedal Lever - Incorrect Material Specification and Adjustment of the Footwell Scuff-Plate on Left Hand Steering Vehicles	

****IMPORTANT INFORMATION****

This Quarantine Notice is issued with Recall Action RA-03-0017 to replace the throttle pedal assembly on all vehicles that are NOT registered that were manufactured from 11 November 2007 until 31 December 2013.

Reason for this Quarantine Notice (QN-03-0019)

Aston Martin has determined that a defect which relates to motor vehicle safety exists on a quantity of vehicles that we manufactured from 11 November 2007 until 31 December 2013. It is possible that the throttle pedal lever on these vehicles can fracture. This is because the material that the lever is made from is not to the design specification. On some left-hand steering vehicles, there can also be a problem with the position of the footwell scuff-plate. If the throttle lever fractures, the throttle will return to the idle position. Loss of function and the inability to influence or maintain engine speed above idle speed will occur.

This Quarantine Notice is applicable to the vehicles that follow that have not yet been given to Customers:

- Right-Hand Steering vehicles from 14 May 2012 until 31 December 2013
- Left-Hand Steering vehicles from 11 November 2007 until 31 December 2013.

Model	Body Type
DB9	Coupe and Volante
DBS	Coupe and Volante
Rapide S	Coupe
V12 Vantage	Coupe
V8 Vantage and V8 Vantage S	Coupe and Roadster

As a precaution, the procedures that follow must be done to every vehicle that is in the separately published list of VINs:

- Change the throttle pedal assembly,
- On Left-Hand steer vehicles, examine and if necessary adjust the position of the footwell scuff-plate.

Notes: *All vehicles that have had the throttle pedal replaced by Quarantine Notice QN-03-0017 and QN-03-0017V2 that are still not registered, must have the throttle pedal replaced again by this Quarantine Notice*

If a vehicle had QN-03-0017V2 completed, only change the throttle pedal. You do not need to adjust the position of the footwell scuff plate again.

If a Left-Hand steer vehicle had QN-03-0017 completed, BUT NOT QN-03-0017V2, examine and if necessary, adjust the position of the footwell scuff-plate.

IMPORTANT!
DO NOT LET THE VEHICLE LEAVE YOUR WORKSHOPS UNTIL THIS QUARANTINE WORK IS COMPLETED.

Contents of this Document

This Quarantine Notice Includes the Sections That Follow:

- Workshop Procedure
 - Part 1 - Change the throttle pedal assembly (all vehicles)
 - Part 2 - Do a check of the throttle pedal movement (all left-hand steer vehicles)
 - Part 3 - If necessary, adjust the footwell scuff-plate (left-hand steer vehicles only)

Workshop Procedure

Part 1 - Change the throttle pedal assembly (all vehicles)

1. Remove the throttle pedal assembly (refer to the Workshop Manual procedure 03.18.AB).
2. Remove the two nuts and Torx screws that attach the pad to the pedal assembly.
3. Put the pad in position on the new throttle pedal assembly.
4. Install and tighten the two nuts and two Torx screws that attach the pad.
5. Install the new throttle pedal assembly (refer to the Workshop Manual procedure 03.18.AB).
6. Make the old throttle pedal assembly unserviceable so that it cannot be used again.

Part 2 - Do a check of the throttle pedal movement (all Left-Hand Steer vehicles)

7. Connect the AMDS to the vehicle.
8. Go to data monitor on AMDS and select PID_309D4: "Relative throttle pedal angle in % (0-100%)" (1) (refer to Figure 1). The PID will be added to the bottom table.
9. Click on "Add" (2).
10. Click on "Close" (3).

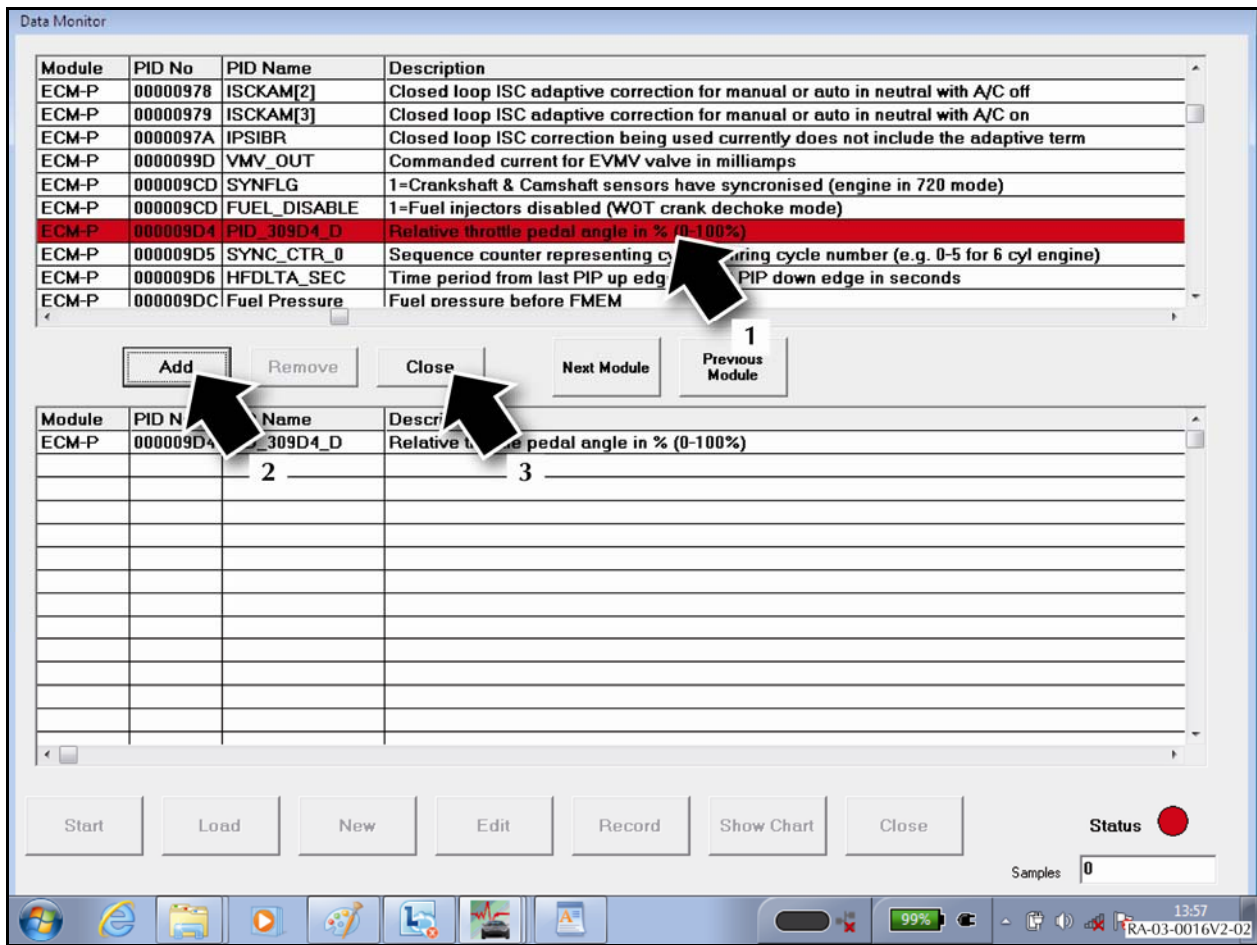

Figure 1

11. The throttle pedal angle screen will be shown (refer to Figure 2).
12. Click on "Start" (1). When you move the throttle pedal, the percentage of the angle of movement will be shown in the "value" cell (2).

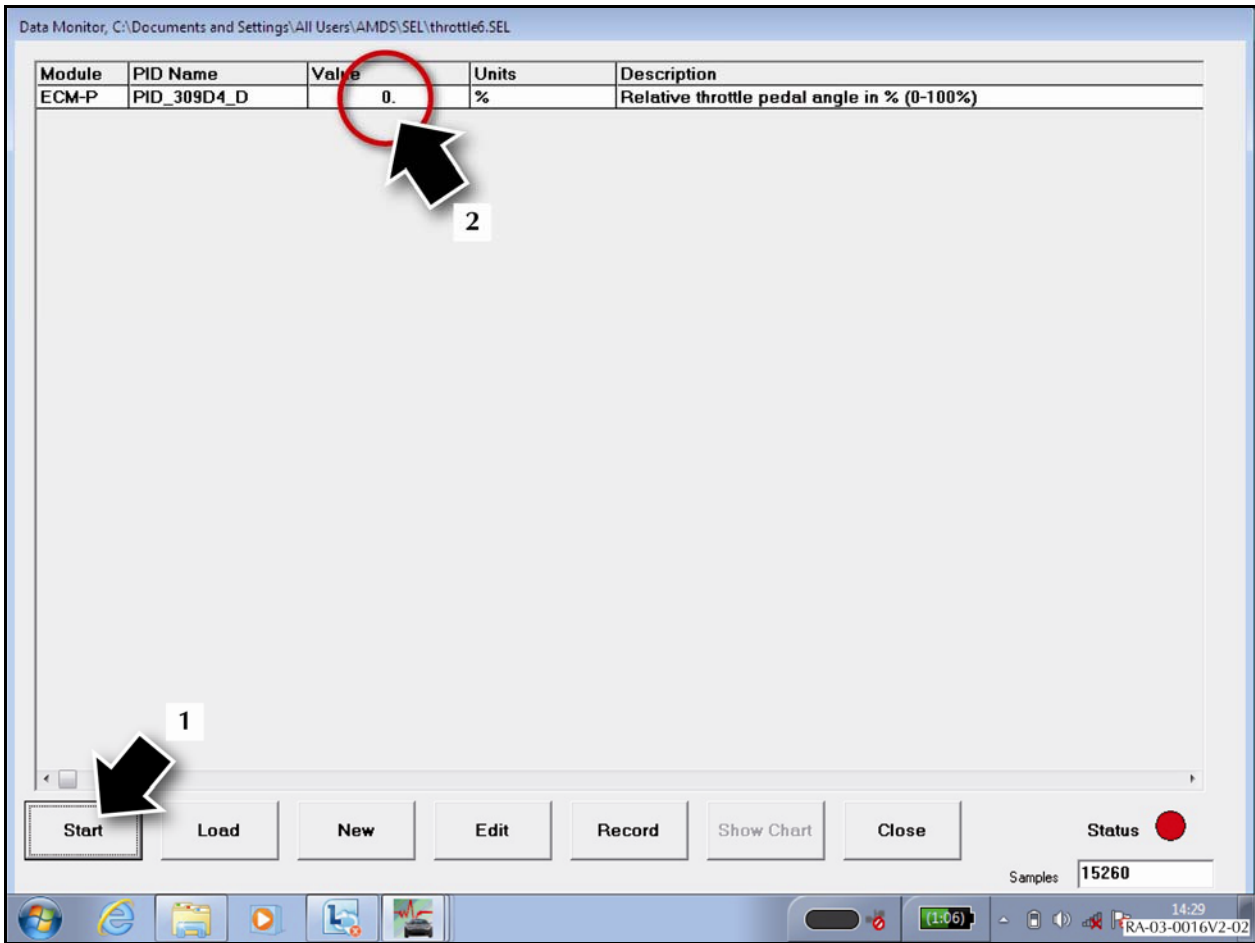

Figure 2

13. Use your hand **only** to fully push the throttle pedal down.
14. Use the AMDS to do a check of the percentage of travel of the throttle pedal. The pedal travel must be **98 percent** or higher.
15. If the pedal does not have the necessary movement, do Part 3 of this procedure that follows:

Part 3 - If necessary, adjust the footwell scuff-plate (Left-Hand Steer vehicles only)

16. On vehicles with B and O audio, do steps 17 thru 19 that follow:
17. Remove the two screws that attach the grille for the driver's side front footwell speaker (footwell speaker) to the bracket (refer to Figure 3).

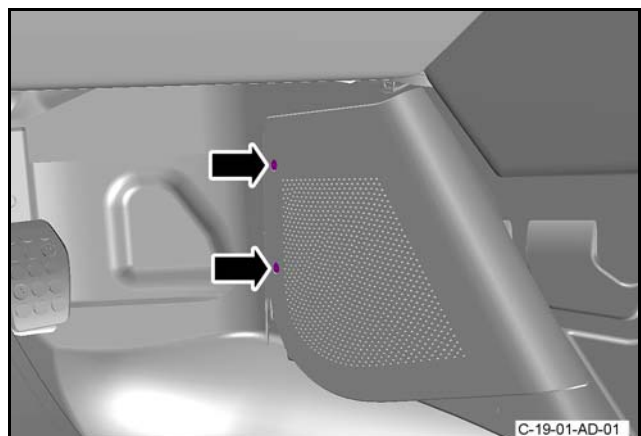

Figure 3

18. Release the grille for the footwell speaker from the two tabs that attach it to the footwell speaker and remove the grille (refer to Figure 4).

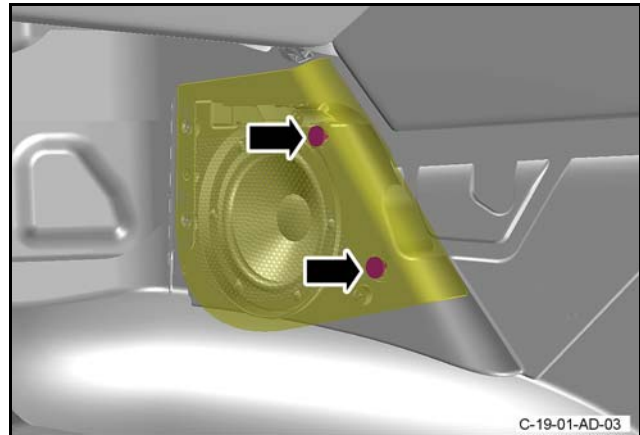

Figure 4

19. Remove the screw that attaches the bracket to the footwell speaker and remove the bracket. (refer to Figure 5).

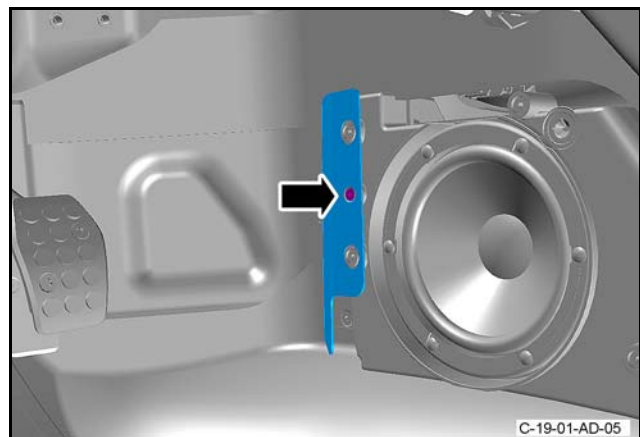

Figure 5

20. On all vehicles, remove the four screws that attach the accelerator scuff-plate (scuff-plate) to the body and remove the scuff-plate (Figure 6).

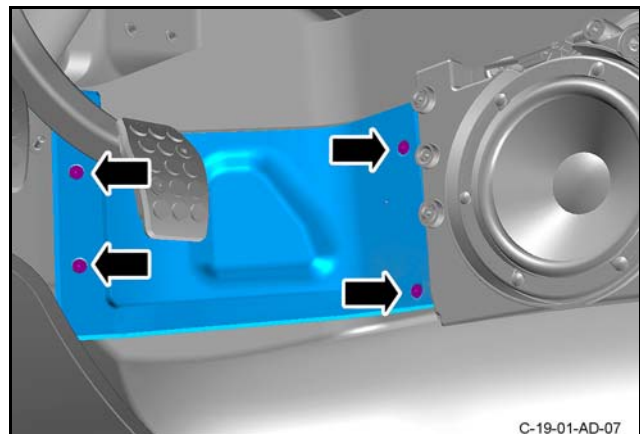

Figure 6

21. On vehicles with B and O audio, do steps 22 thru 24 that follow:

- 22. Move the side tunnel carpet away from the front footwell speaker (refer to Figure 7).

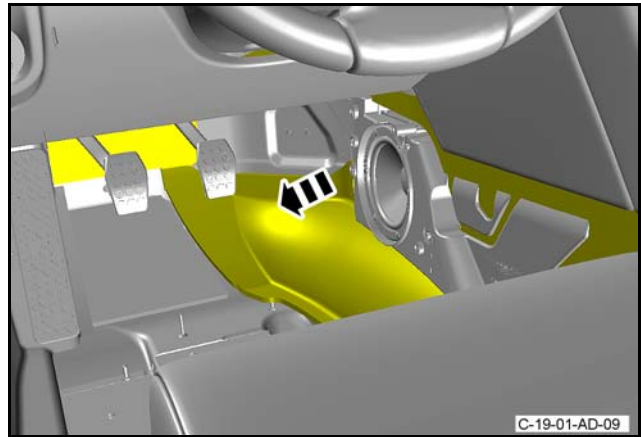

Figure 7

- 23. Disconnect the electrical connector from the footwell speaker (refer to Figure 8).

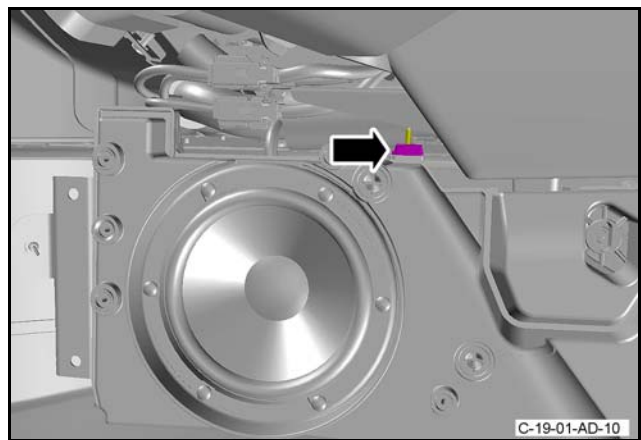

Figure 8

- 24. Remove the two screws that attach the footwell speaker to the body and remove the footwell speaker (refer to Figure 9).

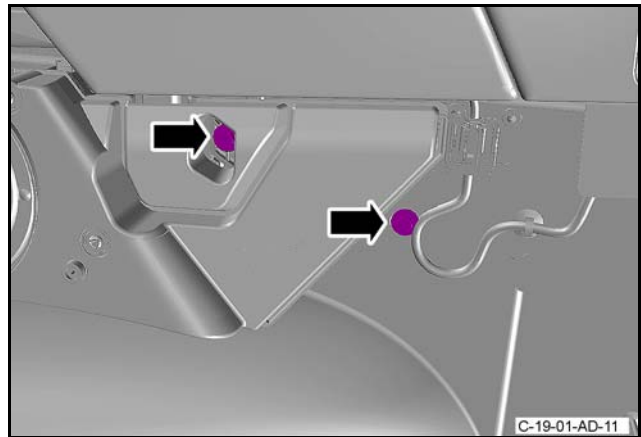

Figure 9

- 25. Cut and remove the piece of carpet that is above the position for the scuff plate (refer to Figure 10). Discard the removed carpet.

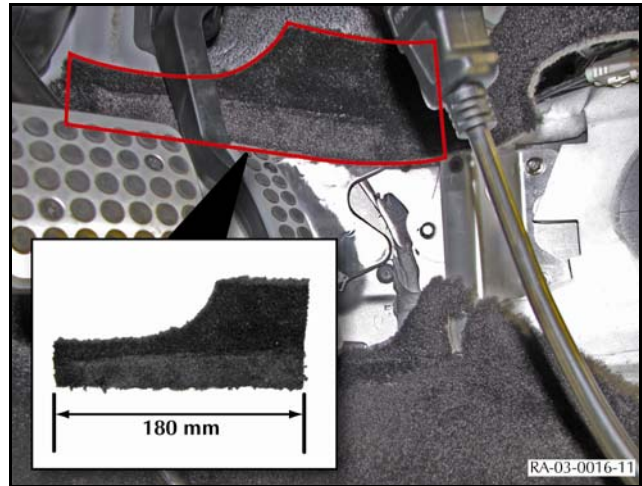

Figure 10

- 26. Cut and remove the piece of insulation (1) that is above the position for the scuff-plate, shown in Figure 11. Discard the removed insulation.



Figure 11

- 27. Loosen, but do not remove the three screws (1) that attach the bracket for the scuff plate (2) to the body (refer to Figure 12).
- 28. Move the bracket (2) fully towards the front of the vehicle (3).
- 29. Tighten the three screws (1) that attach the bracket (2).

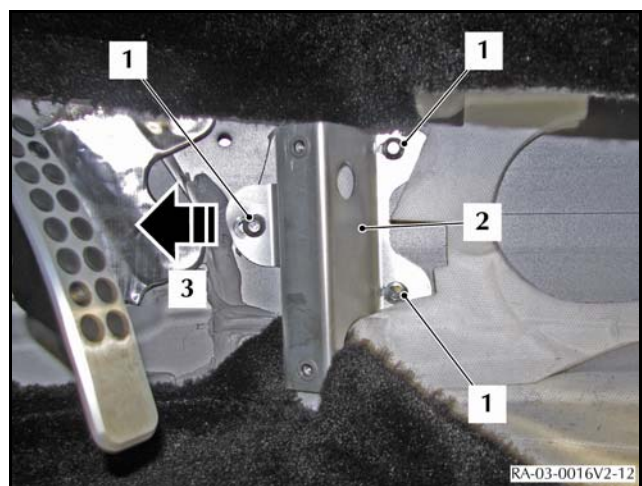

Figure 12

30. Make sure that there is no NVH material (1) on the body where the scuff plate is attached. Remove all NVH material (1) from this area (refer to the example shown coloured green in Figure 13).



Figure 13

31. Use a piece of double-sided adhesive carpet tape approximately 50 mm square (1) to attach the loose end of the carpet to the tunnel (2) (refer to Figure 14).

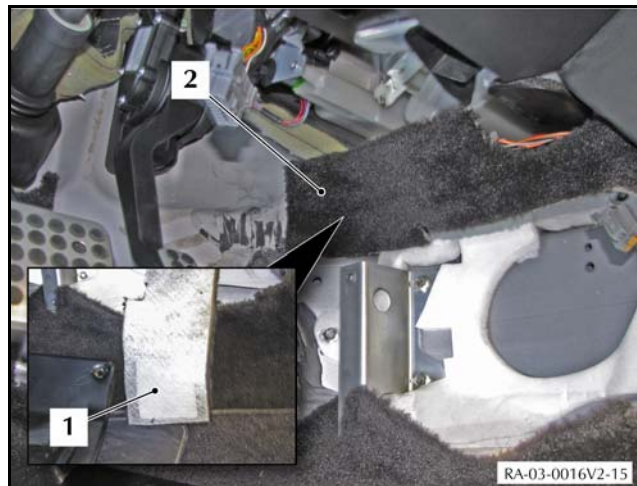

Figure 14

32. On vehicles that have B and O audio, do steps 33 thru 35 that follow:
33. Put the footwell speaker in position (refer to Figure 15).

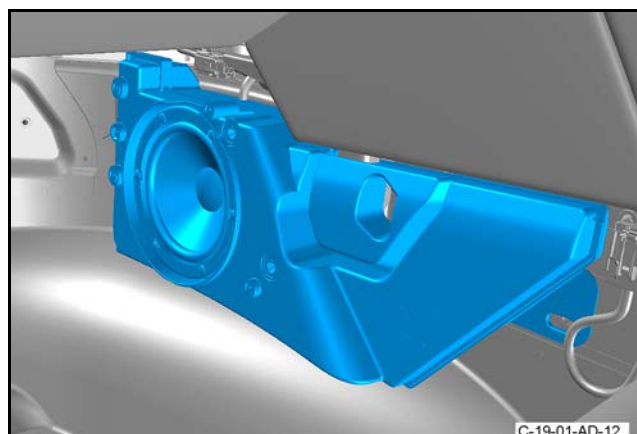

Figure 15

- 34. Install the two screws that attach the footwell speaker (refer to Figure 16).

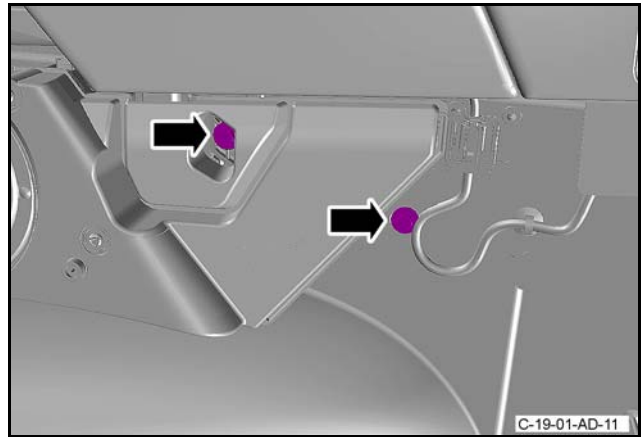

Figure 16

- 35. Connect the electrical connector to the footwell speaker (refer to Figure 17).

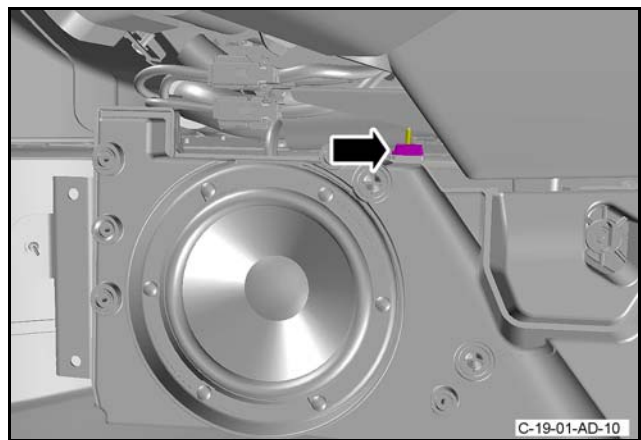

Figure 17

- 36. On all vehicles, put the scuff-plate into position (refer to Figure 18).
- 37. Install and tighten the four screws that attach the scuff-plate.

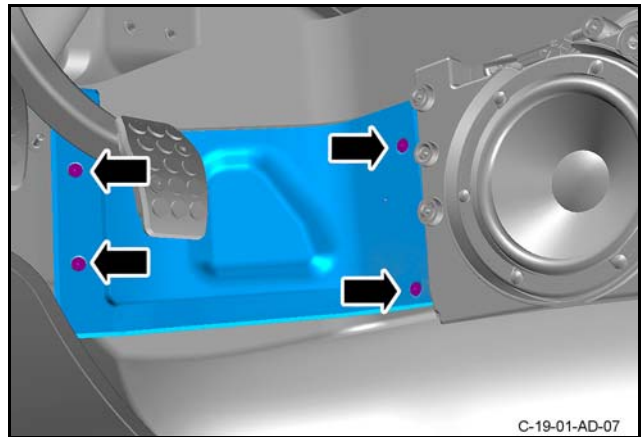

Figure 18

38. On vehicles that have B and O audio, do steps 38 thru 42 that follow:

39. Put the bracket in position at the front of the footwell speaker (refer to Figure 19).

40. Install the screw that attaches the bracket to the footwell speaker.

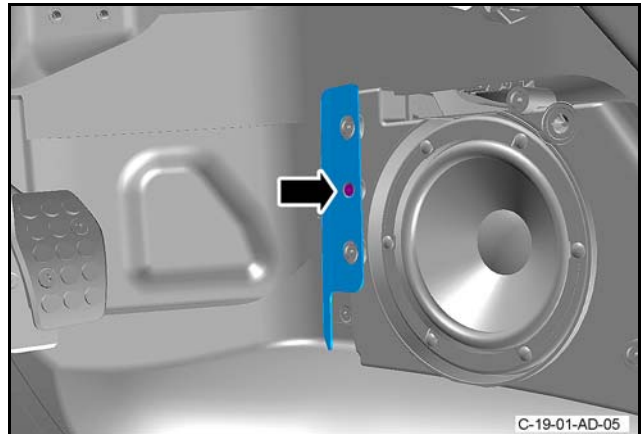

Figure 19

41. Engage the two tabs on the grille for the footwell speaker that attach it to the footwell speaker and attach the grille (refer to Figure 20).

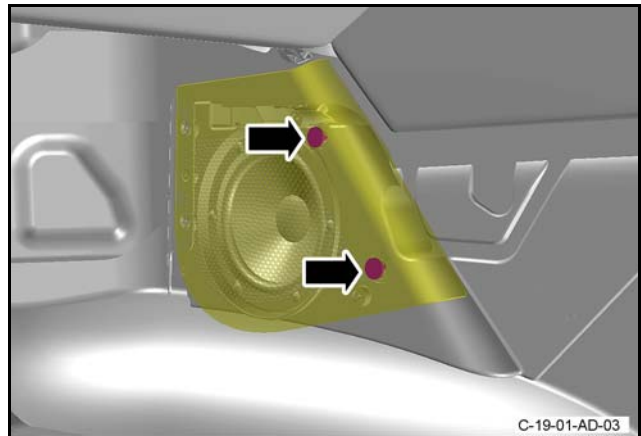

Figure 20

42. Install and tighten the two screws that attach the grille to the footwell speaker (refer to Figure 21).

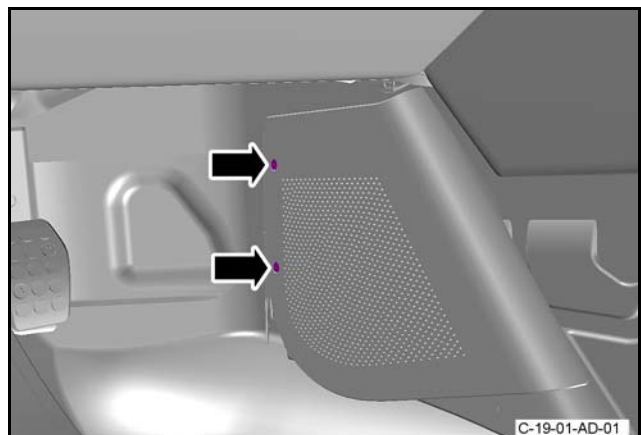

Figure 21

43. Do steps 12 thru 14 of Part 2 of this Workshop Procedure again to do a check of the throttle pedal movement. If the pedal does not have a minimum of **98 percent** movement, please speak to AMTech.

44. Destroy the pedal assembly that you have removed. It is very important that the old pedal assembly cannot be used again.

Warranty Data

Make sure that you submit your claim promptly after the work is completed. The records of your claims are used in the reporting process for the Quarantine Notice that Aston Martin need to submit to the National Highway Traffic Safety Administration.

There are eight tiers in the Warranty database. Please make sure that you refer to the correct tier when you make the claim.

Description	Model	Time	Tier
Replace the Throttle Pedal Assembly	V8, V12 Vantage and Vantage S	0.20 hours	A
	DB9, Virage, DBS, Rapide and Rapide S	0.25 hours	B
Left-Hand Steer, Pedal Replace and do a check of pedal movement	V8, V12 Vantage and Vantage S	0.40 hours	C
	DB9, Virage, DBS, Rapide and Rapide S	0.45 hours	D
Left-Hand Steer, Pedal Replace, do a check of pedal movement and adjust scuff plate position (non-B&O audio)	V8, V12 Vantage and Vantage S	0.65 hours	E
	DB9, Virage, DBS, Rapide and Rapide S	0.70 hours	F
Left-Hand Steer, Pedal Replace, do a check of pedal movement and adjust scuff plate position (B&O audio)	V8, V12 Vantage and Vantage S	0.80 hours	G
	DB9, Virage, DBS, Rapide and Rapide S	0.85 hours	H

Part Data

Model	Description	Part Number	Quantity
DB9 (13MY) (Coupe and Volante) DBS (Coupe and Volante) V8 Vantage (and S) (Coupe and Roadster) V12 Vantage (Coupe) Rapide S (Coupe)	Pedal Assy, Throttle (does not include pad)	8D33-9N734-AC	1

VIN Data

Please refer to the list that is published on DCS for the full VIN List. On DCS select "**Dealer Support**", click on "**After Sales**", then "**Next>>>**", then click on "**General Documentation**" and click on "**RA-03-0017 and QN-03-0019 VINs**".

Note: Please refer to the list on DCS for the vehicles in your region.

If you have any questions related to this Recall Action, please contact: Aston Martin Technical Services on:
+44 (0) 1926 644720 or facsimile: +44 (0) 1926 644733.
E-mail: amtech@astonmartin.com. Or contact your After Sales Manager.

This Recall Action is written in Simplified Technical English to ASD-STE100™.