

S A F E T Y R E C A L L

SUBJECT:	COE Hybrid HV Motor Replacement
DATE:	01/26/2015
BULLETIN NO.:	RCB-004-15
CAMPAIGN NO.:	A9930
AFFECTED MODELS:	2013-2015MY COE (Cab Over Engine) trucks that were assembled at the Hamura, Japan plant equipped with a J05 engine.

NOTE: Refer to the appropriate Vehicle Identification Number (VIN) list to determine vehicle eligibility.

OVERVIEW:

When a driver, while driving, repeatedly accelerates and decelerates, over a short period of time, excessive stress will be applied to the output shaft of the HV motor. The design strength of the output shaft is insufficient and cannot endure such excessive stress. As a result of the rapid acceleration/deceleration and design, the output shaft will become worn, ultimately causing the output shaft to break. The HV motor must be replaced with an updated HV motor that contains a stronger output shaft.

SUBJECT VEHICLES:

2013-2015 MY COE Hino Trucks which were assembled at the Hamura, Japan plant equipped with a J05 engine.

BEFORE YOU BEGIN:

- Read and understand all instructions and procedures before you begin the work.
- Read and follow all **NOTICES** and **WARNINGS** set forth in this publication. These alerts help to avoid damage to components, serious personal injury, or both.
- Park the vehicle on a level and solid surface and apply the parking brake.
- Confirm the engine is stopped, the ignition switch is in the off (LOCK) position, and the key is removed.
- Wear safety glasses to prevent eye injuries.
- Place wheel chocks in front of and behind all wheels.
- Place the gear shift lever in "Neutral" or "N".

S A F E T Y R E C A L L

Once Recall Is Completed
Complete a recall sticker and affix to the left door jam above the V.I.N. decal.



HINO  **TRUCKS**TM
A Toyota Group Company

Campaign No.: _____

Dealer code: _____

Repair date: ____/____/____
(MM / DD / YY)

DO NOT REMOVE

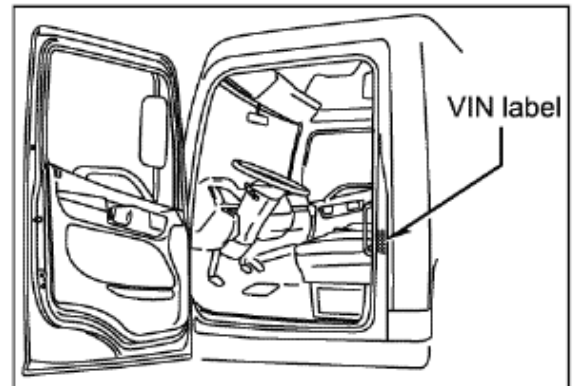

REQUIRED PARTS:

PART NUMBER	DESCRIPTION	QUANTITY
G110037052	MOTOR ASSY, HV	1
9010510558	BOLT (Center Bearing)	8
9415121001	NUT (Center Bearing)	8
9046814016	CLIP (Shift Lever)	1
9418560800	LOCK NUT (Shift Cable)	1
8282477050	Connector, Wiring Harness (For Transmission Harness)	2

VEHICLE PREPARATION

1. Park the vehicle on a level and solid surface.

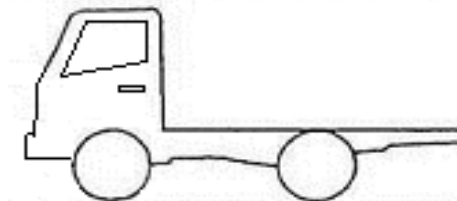

SAFETY RECALL

2. Apply the parking brake.



3. Confirm the engine is stopped, the ignition switch is in the off (LOCK) position, and the key is removed.



4. Chock all of the wheels to prevent the vehicle from moving.



S A F E T Y R E C A L L

HYBRID VEHICLE SERVICE PRECAUTIONS

WARNING: NEVER allow any technician who has not received COE hybrid vehicle training from Hino Motor Sales USA, INC. to work on the Hino hybrid HV System. The hybrid HV system contains a high voltage battery and high voltage circuits. Improper handling of these components can result in serious injury or death due to electrical shock. Ensure that all work is performed correctly and follows closely the procedures set forth within this publication.

1. Technicians performing maintenance or repair on the HV system must have previously received training on the Hino COE Hybrid system.

2. Create a safety zone and surround the work area with orange cones to notify people in the area that high voltage service is being performed. During work on the HV system, prominently display warning signs on all sides of the vehicle which state “Caution High Voltage Work, Do Not Touch this Vehicle!” or words with similar language.



SAFETY RECALL

4. **ALWAYS** wear Hybrid specific, high voltage insulating gloves (Class 0 1000V), safety glasses, and insulated shoes when performing maintenance or repair of the HV system.



5. **NEVER** use insulating gloves that have expired. Prior to each use of the insulating gloves, confirm that the certification date, stamped on the gloves, is within 6 months of the current usage date. The gloves need to be recertified after every six months of use by an approved facility. Check the gloves for cracks, tears, or damage by rolling the gloves to check for air leaks. Do not use any leaking gloves.



CAUTION: The leather portion of the glove must be worn over the red rubber portion of the glove.

SAFETY RECALL

6. Remove the 4 bolts and the service plug cover. Retain the bolts for reinstallation.

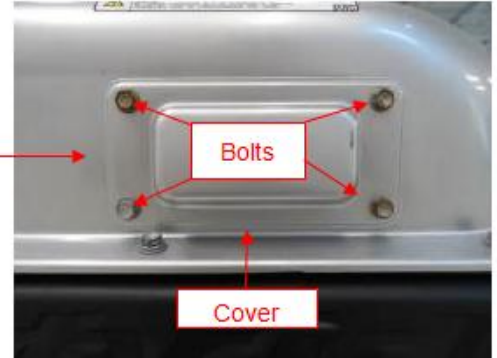

7. Confirm that the ignition switch is in the off (LOCK) position and the key is removed. The HV system service plug must be removed whenever the HV system is being serviced. See the illustration below. **ALWAYS** wait a minimum of seven (7) minutes after the service plug has been removed before beginning service on the HV system to allow the system time to power down fully. Place the service plug in a secure location, which is out of sight, to prevent someone from accidentally connecting it to the vehicle while service is being performed. For safety, reinstall the service plug cover and retaining bolts while the service plug is removed for service of the HV system.

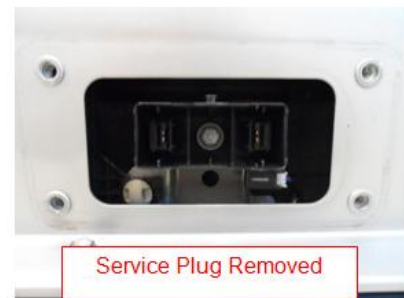

CAUTION: NEVER turn the ignition switch to the “ON” position any time the service plug is removed. This can result in damage to the vehicle’s electrical system and create fault codes.

SAFETY RECALL

8. Disconnect the negative terminal of the 12 volt battery.

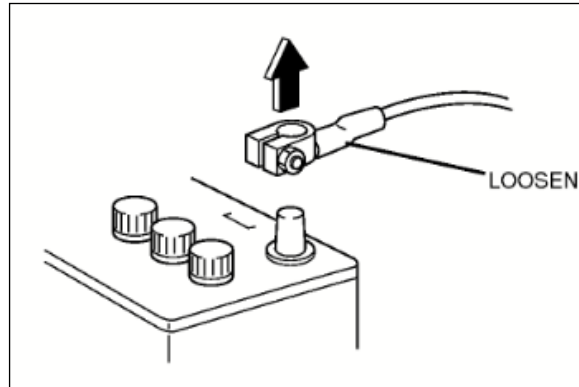

9. While performing service, ensure that the work area is clear of all loose metal objects such as socket extensions, bolts, nuts, etc. which could cause HV circuits to short circuit if dropped. **ALWAYS** use the Hybrid Insulated Tool kit (No. HDT-195HVST) provided when working with HV circuits or terminals. **NEVER** use other tools.



10. High voltage circuit harnesses are colored **ORANGE**. **NEVER** touch the connections of these high voltage circuits unless required to do so.



SAFETY RECALL

11. Remove the 4 push pin retainers from underneath the Hybrid battery unit and retain for reinstallation.

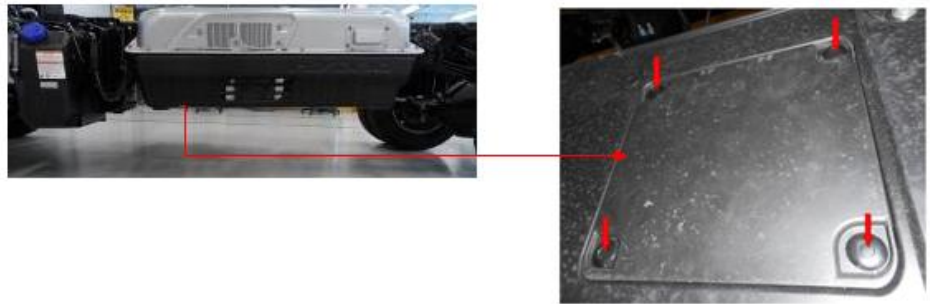

12. Remove the 4 retaining bolts and the terminal inspection cover and retain for reinstallation.

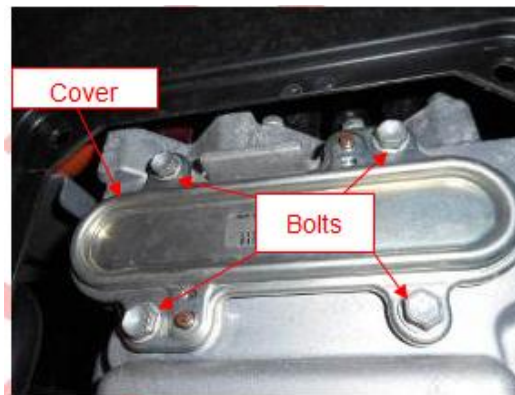

13. **ALWAYS** wear the hybrid-specific insulating gloves before touching any high voltage circuit, and verify that the voltage on that circuit is at 0V (zero voltage) using a Megger Meter. The meter is shown in the photograph to the right. The Megger Meter must be able to generate up to 1000V DC and deliver a resistance value in Mega ohms.



S A F E T Y R E C A L L

14. Ground the Megger Meter to the inverter case. Verify that the meter operates properly on a 12V system prior to performing any high voltage checks. This will ensure proper operation of the meter.

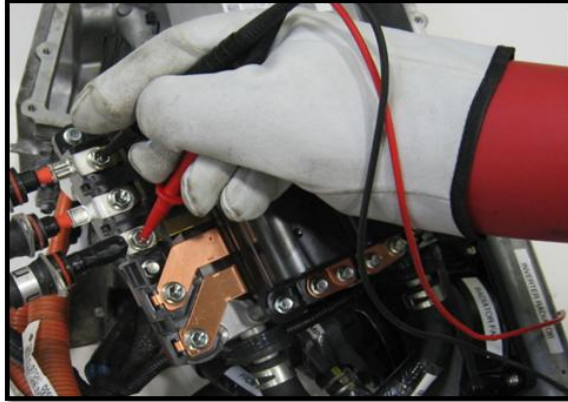

NEVER use two hands to check voltage readings. Using only one hand (the one hand rule), check each terminal within the inverter opening for any voltage on the 5 terminals. The Megger Meter should indicate .01 volts or less on each terminal and circuit.

WARNING: NEVER proceed with this service campaign if any voltage is present on the HV circuits. Verify that all steps, above, have been performed as directed. If all steps were performed as directed, connect the HV service plug and the 12 volt battery. Use the Hino DXII to check for any DTC's (Diagnostic Trouble Codes) and follow the diagnostics in the Workshop Manual as needed.

REPAIR PROCEDURE

WARNING: Be certain that all steps of the Hybrid Vehicle Service Precautions procedure, specified above, have been completed prior to performing this Repair Procedure. Failure to properly perform the HV system service disconnect, and complete all steps of the procedure, can result in personal injury or death due to electrical shock.

NOTICE: Hino COE Hybrids are offered in both single cab and crew cab form. The photographs throughout this procedure will depict a single cab vehicle, but the removal and installation procedure for crew cab vehicles will be similar.

CREW CAB ENGINE COVER REMOVAL PROCEDURE

NOTE: This procedure does not apply to single cab vehicles. For single cab vehicles, proceed to the Disassembly procedure, below.

S A F E T Y R E C A L L

1. From the back seat, disconnect the 4 snaps at the front of the rear rubber floor cover. Pull the floor cover back slightly.

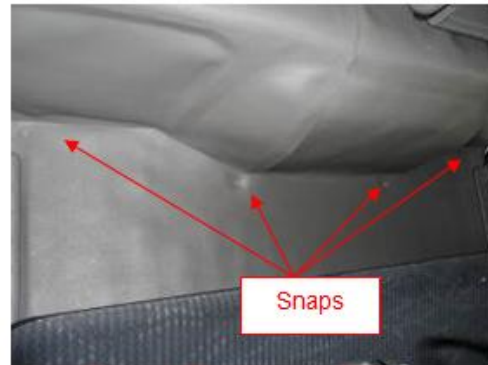

2. Disconnect all of the snaps from the upper rubber cover. Remove the cover.



3. Remove the 12 bolts from the rear engine cover. Remove the cover to access the rear of the engine. Retain the bolts and cover for reinstallation. Proceed to the Disassembly procedure, below.

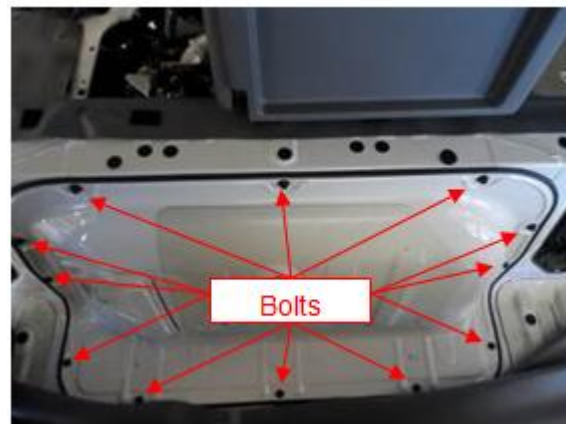

S A F E T Y R E C A L L

DISASSEMBLY PROCEDURE

1. Use a paint marker to create alignment marks on the yoke at the rear axle flange, and on the yoke that attaches to the transmission output shaft flange.

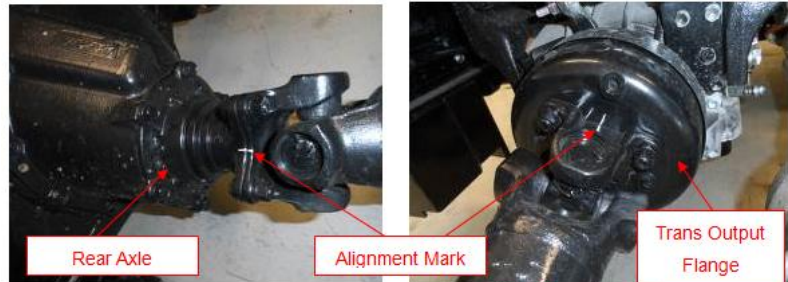

2. Remove the 4 nuts at the rear axle yoke, and the 4 nuts at the transmission output yoke and retain for reinstallation. Tap on the flanges using a rubber mallet to separate each yoke from the flange.

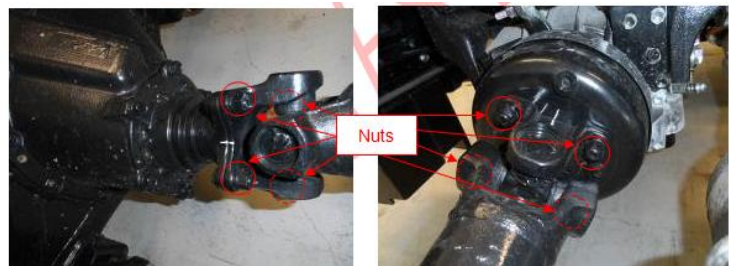

CAUTION: Do not let the drive shaft yoke fall and hit the floor when loosening it from the flanges. Support the driveshaft by hand when loosening the yokes from the flanges.

3. Support the drive shaft with straps or a jack. Remove and discard the 4 bolts and 4 nuts which retain the center bearing to the frame. Have an assistant help remove the drive shaft assembly from under the vehicle.

WARNING: ALWAYS use an assistant when removing the drive shaft. The drive shaft is heavy. **NEVER** lie directly under the drive shaft when removing the nuts from the center bearing. A falling drive shaft could cause personal injury or death.

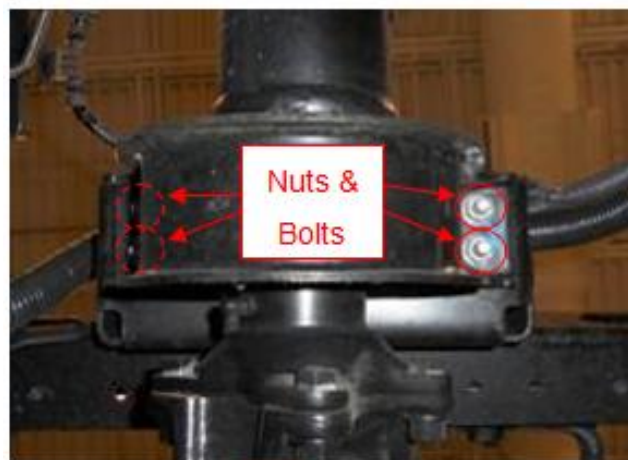

S A F E T Y R E C A L L

4. Release the parking brake.



5. Locate the parking brake cable joint coupler on the passenger's side of the vehicle next to the HV motor. Remove the nut from the joint coupler and retain for reinstallation.

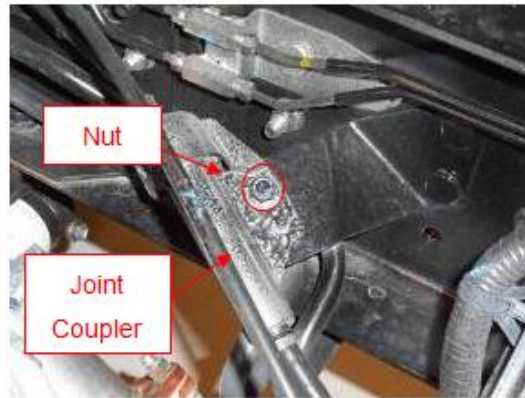

6. Twist the parking brake cable joint coupler to expose the parking brake cable connection. Separate the two halves of the parking brake cable by pulling the chassis end of the cable through the window of the transmission end of the cable. Tie the loose chassis side cable to the frame while the HV motor is being serviced.

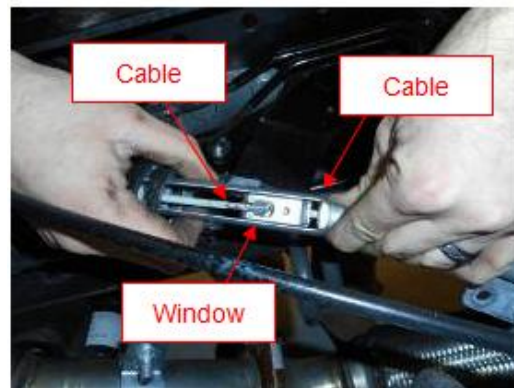

S A F E T Y R E C A L L

7. Remove the bolt attaching the parking brake cable bracket to the transmission mount and retain for reinstallation. Tie the loose hanging cable and bracket to the transmission.

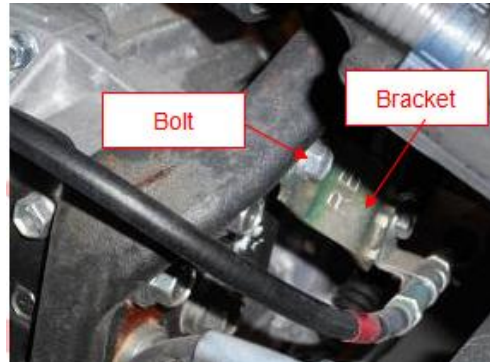

8. From the driver's side of the vehicle, remove the 2 bolts attaching the HV cable support bracket to the transmission and retain for reinstallation.

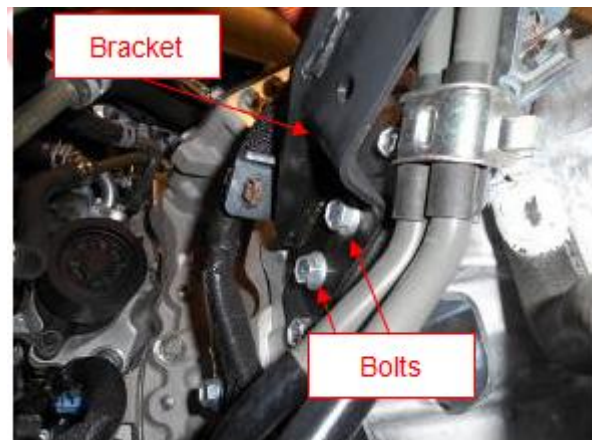

9. Remove the 6 bolts and clamps that retain the transmission cooler lines together between the side of the engine and the transmission and retain for reinstallation.

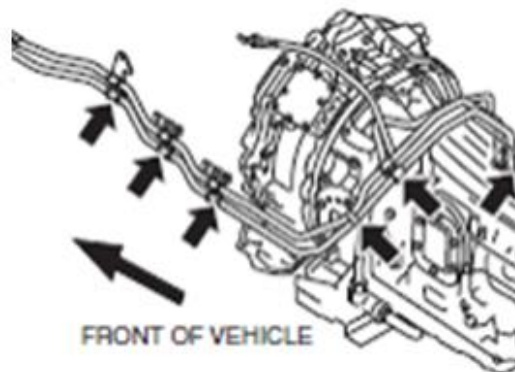

S A F E T Y R E C A L L

10. Place a drain pan under the cooler lines where they attach to the transmission. Remove the fittings that retain the cooler lines to the transmission. Remove the cooler lines from the transmission. Tie the cooler lines up away from the transmission.



11. Remove and discard the clip that retains the shifter cable to the shifter cable bracket. Remove and discard the nut that retains the shifter cable to the shift lever on the transmission. Tie the loose shift cable to the frame of the vehicle.

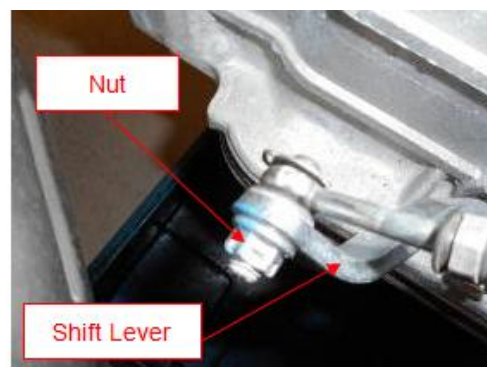
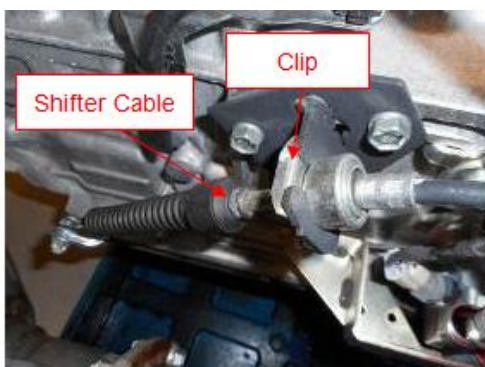

12. Remove the 2 bolts which secure the upper dipstick tube to the HV motor and retain for reinstallation. Remove the upper dipstick tube from the lower dipstick tube. Ensure that the O-ring seal on the upper dipstick tube stays with the dipstick tube.

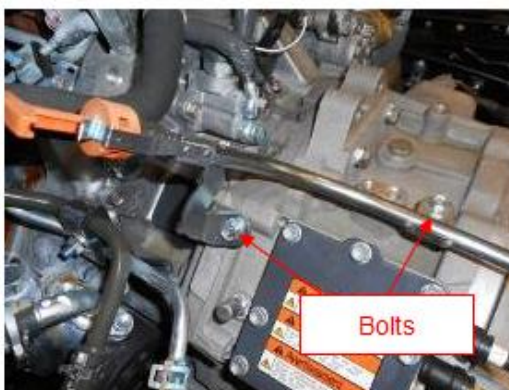

S A F E T Y R E C A L L

13. Disconnect the 3 inline harness connectors on top of the transmission. Be careful not to break the white locking levers on the 24 way transmission connectors. If the locking levers break, remove the locking lever from a new connector shell (Part No. 8282477050) and transfer it to the effected connector on the vehicle.



14. Disconnect the two harness connectors on the passenger's side of the HV motor.



15. Disconnect the HV motor oil pump connector and oil pump solenoid connector from the driver's side of the HV motor. Remove the ground bolt from the HV motor.

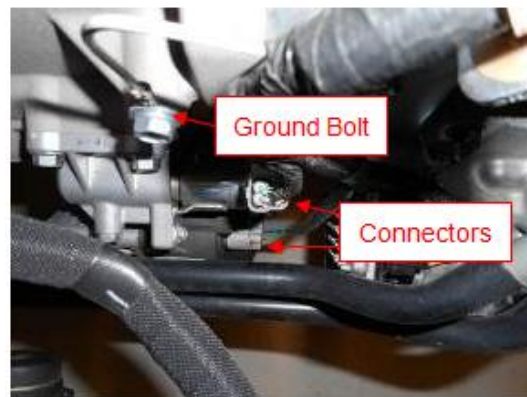

S A F E T Y R E C A L L

16. Remove the 8 bolts from the HV motor cover. Remove and discard the motor cover, and motor cover gasket.



17. Remove the 6 bolts retaining the HV cables to the HV motor. Discard the 3 terminal bolts which were located under the HV motor cover, these bolts will be included with the new HV motor. Retain the other 3 bolts for reinstallation.

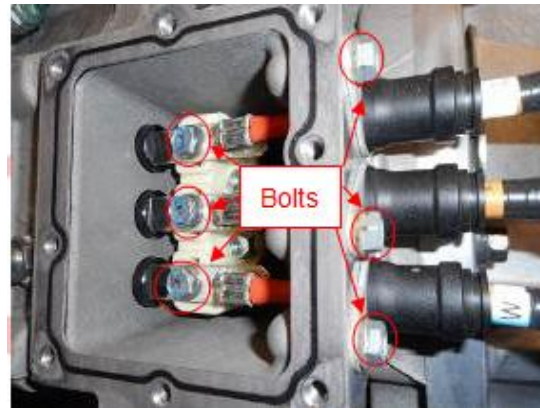

WARNING: ALWAYS use the insulated tools and insulated gloves during this step. Such use is required. Failure to wear high voltage safety gloves may result in personal injury or death due to electrical shock.

18. Remove the HV cables from the HV motor. Insulate the metal terminals of the HV cables using electrical tape. Tie the loose hanging cables to the frame of the vehicle.



S A F E T Y R E C A L L

19. Remove the 2 bolts from the dust shield on the back of the engine. Remove the dust shield to access the ring gear. Retain the bolts and dust shield for reinstallation.

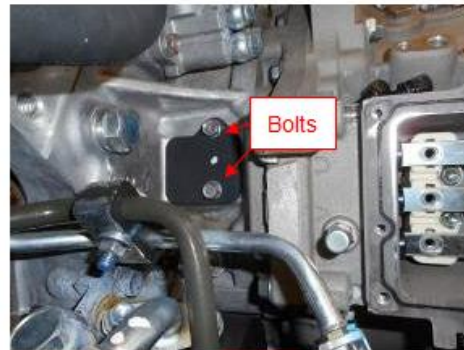

20. Remove the 2 bolts from the dust shield on the bottom of the transmission. Remove the dust shield from the transmission to access the torque converter bolts. Retain the bolts and dust shield for reinstallation.



21. Remove the 6 torque converter bolts and retain for reinstallation. To access each torque converter bolt, rotate the engine using a pry bar on the ring gear through the access hole at the back of the engine which was exposed in step 19, above.

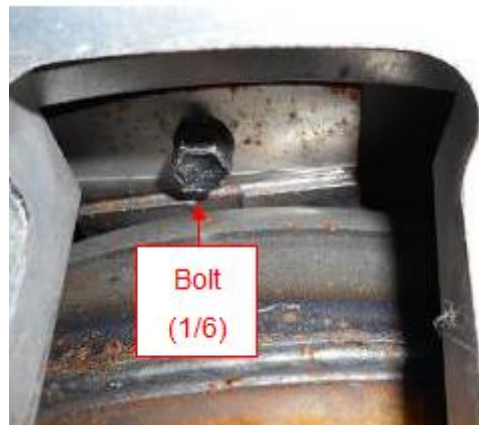

S A F E T Y R E C A L L

22. Support the bell housing of the engine using a jack and a block of wood.



23. Support the transmission using a transmission jack with an appropriate adapter.

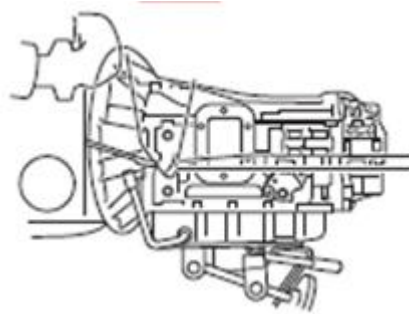

24. Make certain that the transmission is properly supported on the transmission jack. Remove the 8 transmission mount bolts (4 per side) from the back of the transmission and retain for reinstallation. The passenger's side is shown in the illustration, but the driver's side is similar.

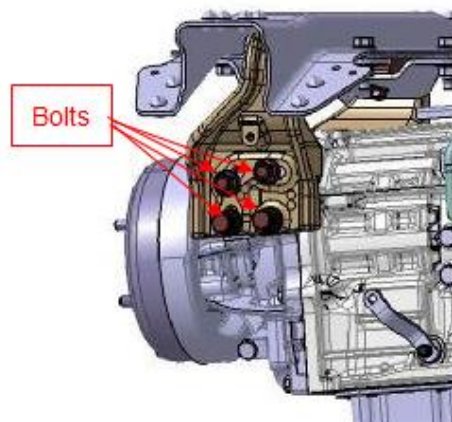

S A F E T Y R E C A L L

25. Make certain that the transmission is properly supported on the transmission jack. Remove the 12 bolts that attach the transmission to the HV motor and retain for reinstallation. Separate the transmission from the HV motor. Move the transmission out of the way.

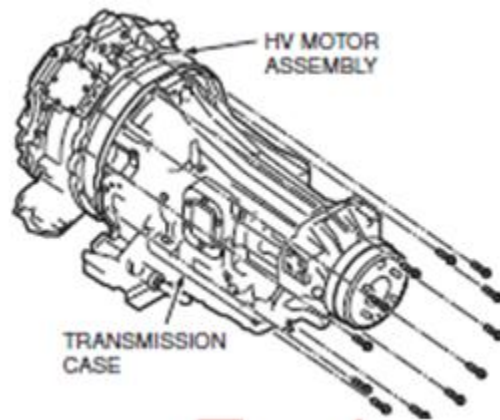

WARNING: The transmission is extremely heavy. A falling transmission could cause personal injury or death. **NEVER** attempt removal of the transmission unless the transmission is securely supported by the transmission jack.

26. Support the HV motor using a jack with an appropriate adapter that will secure the HV motor to the jack. If the vehicles box (or cab) does not restrict access, and an overhead crane is available, the HV motor can be attached to a lifting hook, and then lowered onto the ground using the crane. Once secure, remove the 12 bolts that attach the HV motor to the engine and retain for reinstallation. Once the bolts are removed, separate the HV motor from the engine and remove it from underneath the vehicle. Proceed to the Assembly procedure, below.

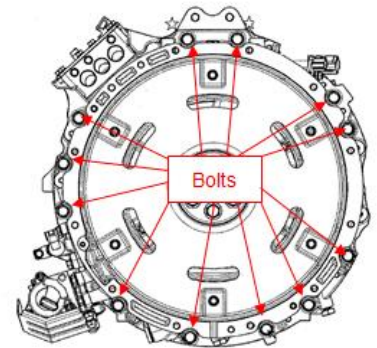

WARNING: ALWAYS use an assistant when removing the HV motor. The HV motor is very heavy. **NEVER** lie directly under the HV motor when removing the bolts that attach it to the engine. A falling HV motor could cause personal injury or death.

S A F E T Y R E C A L L

ASSEMBLY PROCEDURE

1. Coat the input shaft splines on the new HV motor (Part No. G110037052) with grease. Support the new HV motor using a jack with an appropriate adapter that will secure the HV motor to the jack. If the vehicles box (or cab) does not restrict access, and an overhead crane is available, the HV motor can be attached to a lifting hook, and raised up to the engine using the crane. Once raised up to the engine, align the HV motor input shaft splines to the flywheel on the engine. It may be difficult to insert the splines into the flywheel. The HV motor needs to be aligned perfectly to the engine for the input shaft splines to go into the flywheel. Use the 2 longer HV motor mounting bolts which are normally in the top 2 bolt holes to guide the HV motor into place. See the illustration. Insert these 2 longer bolts into two of the holes on the sides of the HV motor, directly across from each other. Tighten the bolts down evenly from side to side using minimal torque. If any binding is felt while tightening the bolts, stop tightening, loosen them, reposition the HV motor, and try again. Once the HV motor is aligned with the dowels on the rear surface of the engine, Install the 10 shorter bolts that attach the HV motor to the engine. Remove the longer bolts and install them in the top two holes. Tighten all of the bolts to the specified torque.

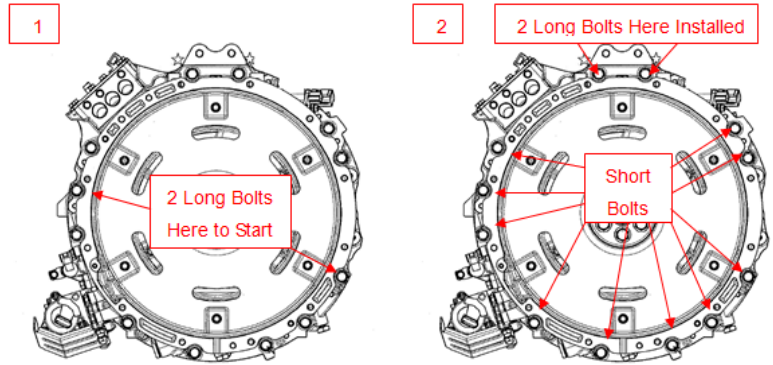

Specified Torque: 41 lb-ft (55 Nm)

S A F E T Y R E C A L L

WARNING: ALWAYS use an assistant when moving the HV motor. The HV motor is very heavy. **NEVER** lie directly under the HV motor when installing the bolts that attach it to the engine. A falling HV motor could cause personal injury or death

2. Make certain that the transmission is properly supported on the transmission jack. Align the transmission bell housing to the dowel pins on the HV motor. Once aligned, install the 12 bolts which retain the transmission to the HV motor. Tighten the bolts to the specified torque.

Specified Torque: 32 lb-ft (43 Nm)

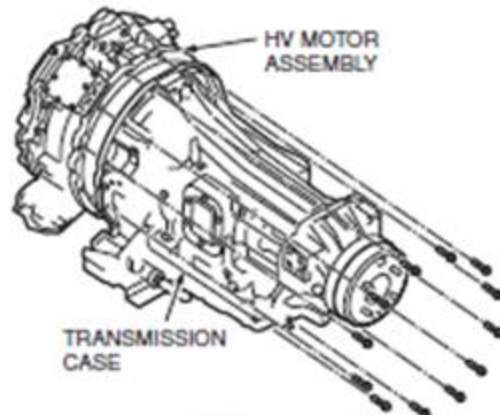

WARNING: The transmission is extremely heavy. A falling transmission could cause personal injury or death. **NEVER** attempt installation of the transmission unless the transmission is securely supported by the transmission jack.

3. Make certain that the transmission is properly supported on the transmission jack. Install the 8 transmission mount bolts (4 per side) into the back of the transmission. The passenger's side is shown, but the driver's side is similar. Tighten the bolts to the specified torque. Remove the transmission jack, and the jack which is supporting the bell housing on the engine.

Specified Torque: 76 lb-ft (103 Nm)

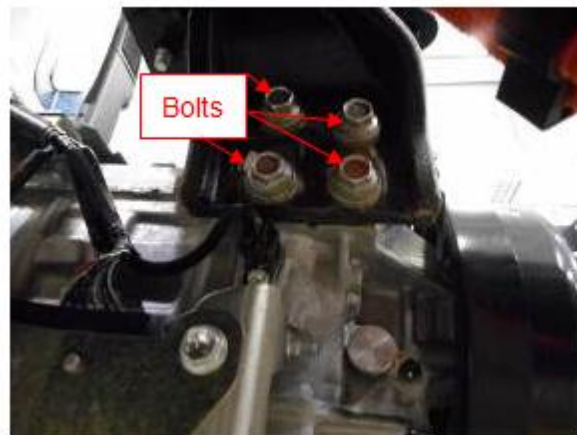

SAFETY RECALL

- Loosely install the 6 torque converter bolts. To access each torque converter bolt, rotate the engine using a pry bar on the ring gear through the access hole at the back of the engine. With all 6 bolts loosely installed, tighten the bolts to the specified torque.

Specified Torque: 40 lb-ft (54 Nm)



- Install the 2 bolts into the dust shield on the bottom of the transmission. Tighten the bolts to the specified torque.

Specified Torque: 13 lb-ft (18 Nm)

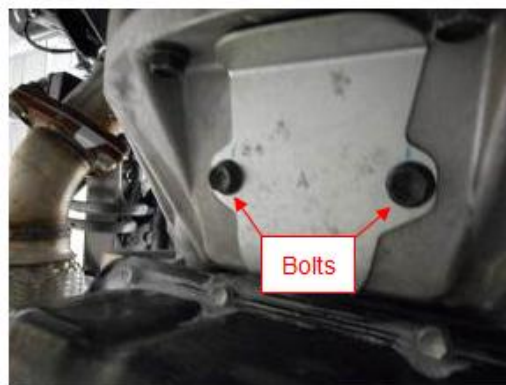

- Install the 2 bolts into the dust shield on the back of the engine. Tighten the bolts to the specified torque.

Specified Torque: 13 lb-ft (18 Nm)

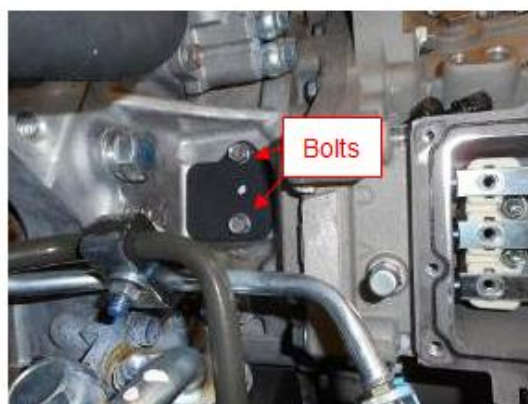

S A F E T Y R E C A L L

7. Remove the electrical tape insulating the HV cable terminals.



8. Remove the HV terminal cover from the new HV motor and discard the 2 bolts which were holding it on. The new HV motor should include 3 new terminal bolts. Remove these 3 bolts then insert the HV cables into the HV motor. Ensure that the W, V, and U cables, depicted in the photograph on the right, are positioned correctly into the motor. Install the 3 bolts which secure the HV cables to the HV motor, then tighten the bolts to the specified torque. Install the 3 cable terminal bolts, and then tighten them to the specified torque.

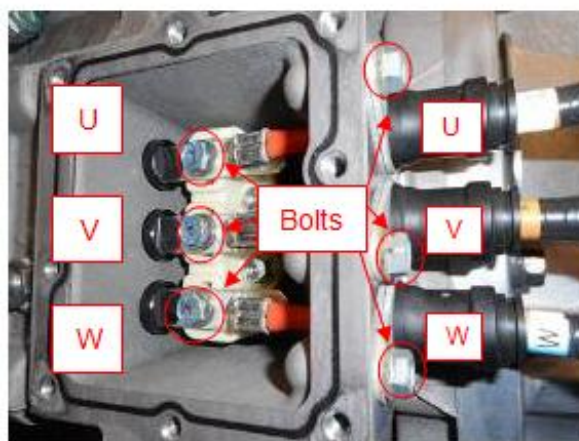

Specified Torque: 7 lb-ft (9 Nm)

WARNING: ALWAYS use the insulated tools and insulated gloves during this step. Such use is required. Failure to wear high voltage safety gloves may result in personal injury or death due to electrical shock.

S A F E T Y R E C A L L

9. Verify the HV motor terminal cover high voltage warning label is on top of the new HV motor terminal cover as shown in the photograph on the right. **If the high voltage warning label is not present, contact PDC (866) 372-4466 immediately.** The warning label should be placed 18mm (3/4 inch) from the bottom and side edges of the terminal cover.



NOTICE: The top of the HV motor cover has recessed areas around the bolt holes.

WARNING: NEVER install an HV motor terminal cover that does not have a high voltage warning label affixed to it. Failure to install the warning label may result in personal injury or death due to electrical shock. In the future, without this label, someone could remove the HV motor terminal cover without being aware of the danger of high voltage and without disabling the hybrid system in a proper manner before beginning work.

10. Install the new HV motor cover onto the new HV motor using the new gasket supplied with the motor. Install the 8 bolts into the HV motor cover. Tighten the bolts to the specified torque.

Specified Torque: 7 lb-ft (9 Nm)

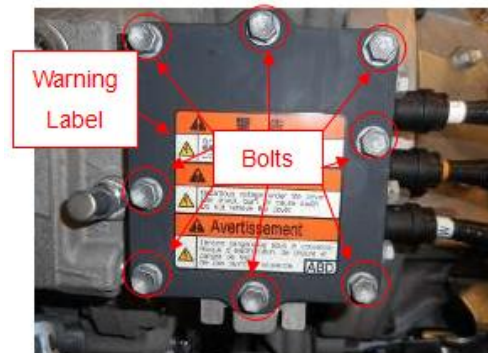

WARNING: NEVER install an HV motor terminal cover that does not have a high voltage warning label affixed to it. Failure to install the warning label may result in personal injury or death due to electrical shock. In the future, without this label, someone could remove the HV motor terminal cover without being aware of the danger of high voltage and without disabling the hybrid system in a proper manner before beginning work.

S A F E T Y R E C A L L

11. On the driver's side of the vehicle, connect the HV motor oil pump connector and oil pump solenoid harness connector to the HV motor. Install the ground cable bolt through the ground loop and into the HV motor. Tighten the ground bolt to the specified torque.

Specified Torque: 13 lb-ft (18 Nm)

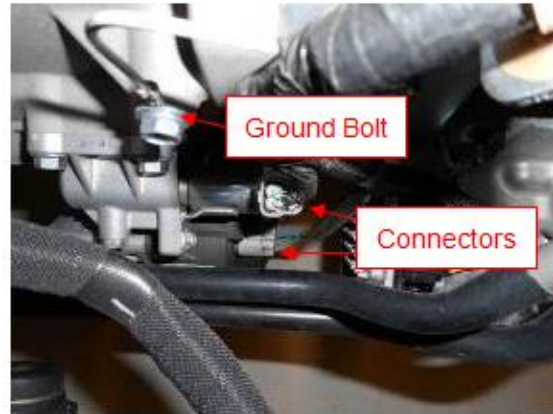

12. Connect the two harness connectors to the passenger's side of the HV motor.



13. Connect the 3 inline harness connectors on top of the transmission. If the locking lever on the 24 pin connector was broken, remove the locking lever from a new connector shell (Part No. 8282477050) and transfer it to the effected connector on the vehicle.



S A F E T Y R E C A L L

14. Ensure that the O-ring seal on the upper dipstick tube is still on the end of the dipstick tube. Install the upper dipstick tube into the lower dipstick tube. Install the 2 bolts which retain the upper dipstick tube to the HV motor. Tighten the bolts to the specified torque.

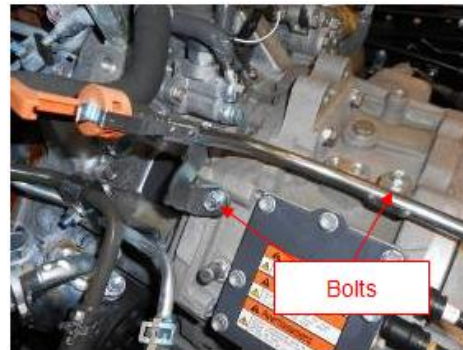

Specified Torque: 13 lb-ft (18 Nm)

15. Insert the shifter cable into the shifter cable bracket. Install the new clip (Part No. 90468-14016) that retains the shifter cable to the shifter cable bracket. Insert the shifter cable stud through the shift lever. Install a new nut (Part No. 94185-60800) on the shift lever stud and tighten the nut to the specified torque.



Specified Torque: 18 lb-ft (24 Nm)

16. Install the transmission cooler line fittings into the transmission. Tighten the fittings to the specified torque.



Specified Torque: 27 lb-ft (36 Nm)

S A F E T Y R E C A L L

17. Install the 6 bolts and clamps that retain the transmission cooler lines together between the side of the engine and the transmission. Tighten the bolts to the specified torque.

Specified Torque (A): 13 lb-ft (18 Nm)

Specified Torque (B): 5 lb-ft (7 Nm)

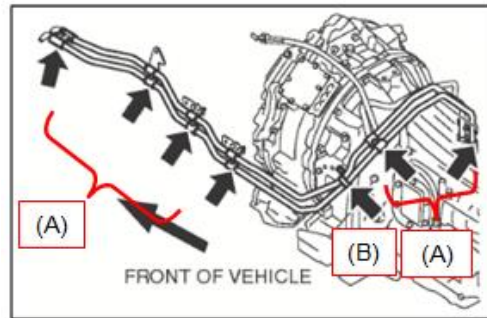

18. From the driver's side of the vehicle, install the 2 bolts attaching the HV cable support bracket to the transmission. Tighten the bolts to the specified torque.

Specified Torque: 14 lb-ft (19 Nm)

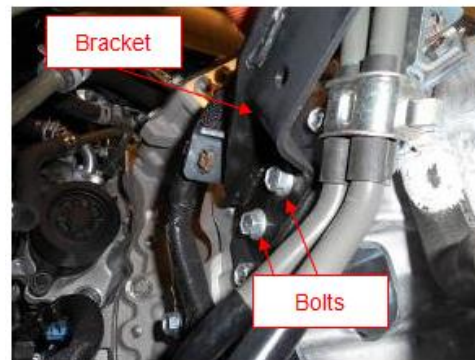

19. Install the bolt attaching the parking brake cable bracket to the transmission mount. Tighten the bolt to the specified torque.

Specified Torque: 14 lb-ft (19 Nm)

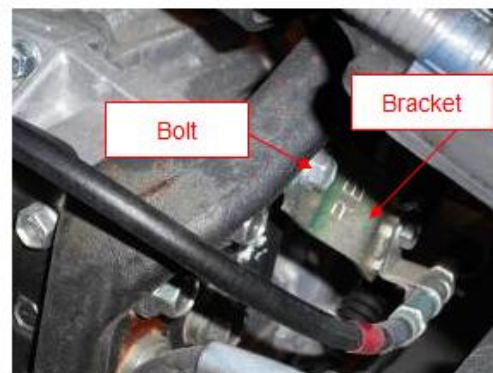

S A F E T Y R E C A L L

20. Connect the two halves of the parking brake cable by inserting the chassis end of the cable through the window of the transmission end of the cable. Twist the parking brake cable joint coupler together to connect the two cables.

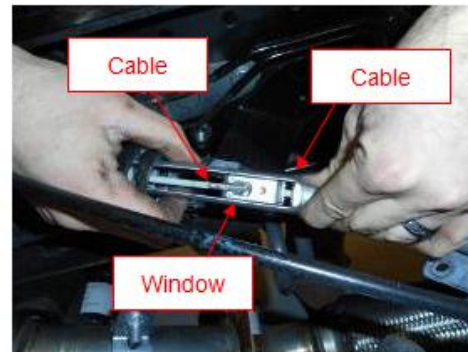

21. Install the nut which retains the parking brake cable joint coupler. Tighten the nut to the specified torque.

Specified Torque: 14 lb-ft (19.5 Nm)

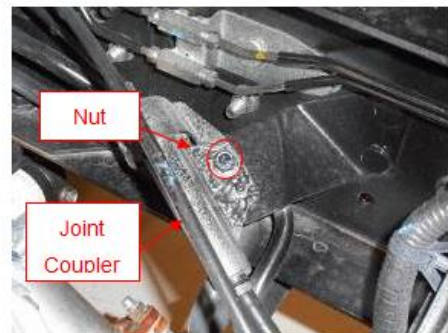

22. Apply the parking brake.



S A F E T Y R E C A L L

23. Align the drive shaft using the alignment marks which were previously marked. Install the 4 nuts at the rear axle yoke, and the 4 nuts at the transmission output yoke. Tighten the nuts to the specified torque.

Specified Torque: 55 lb-ft (74.5 Nm)

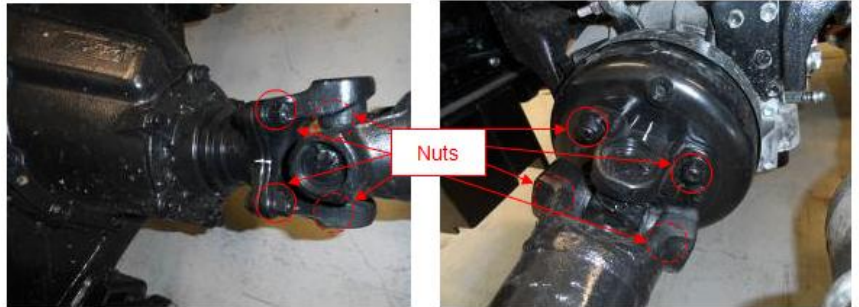

24. Use a jack to raise the drive shaft center bearing to the frame. Have an assistant help position the drive shaft into place. Install 4 new bolts (Part No. 9010510558) and 4 new nuts (Part No. 9415121001) which retain the center bearing to the frame. Tighten the nuts to the specified torque.

Specified Torque: 26 lb-ft (35 Nm)

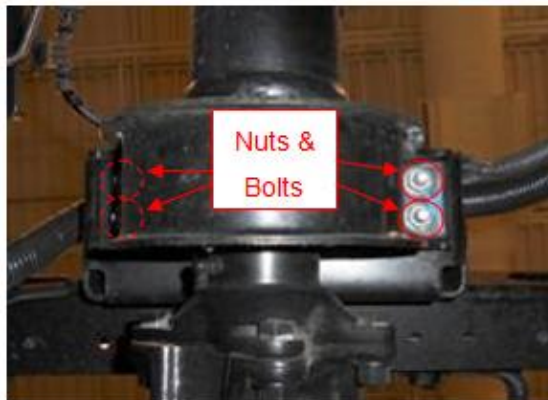

WARNING: ALWAYS use an assistant when removing the drive shaft. The drive shaft is heavy. **NEVER** lie directly under the drive shaft when installing the bolts to the center bearing. A falling drive shaft could cause personal injury or death.

S A F E T Y R E C A L L

25. It is necessary to verify that the fluid in the new HV motor is full. Remove the fluid level check plug. If fluid streams out from the level check plug port, the fluid level is full and no fluid needs to be added. Reinstall the level check plug once fluid stops running out. If fluid does not stream out of the fluid level check port, add Toyota Type-IV automatic transmission fluid to the fluid fill port until fluid starts running out of the fluid level check port. Tighten both plugs to the specified torque once the fluid level is full in the HV motor.

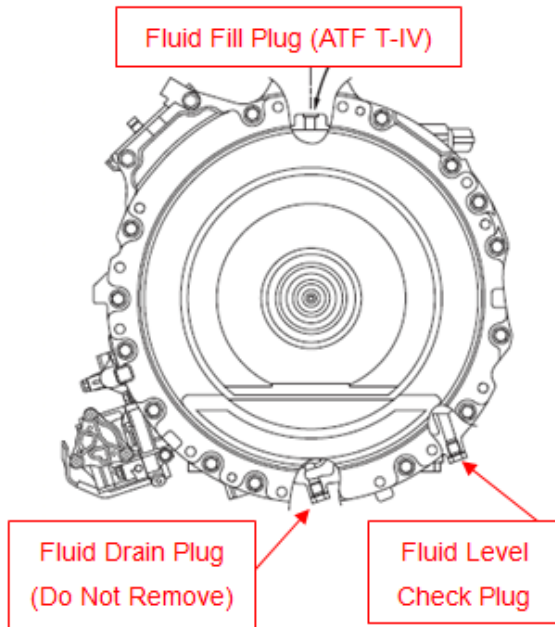

Specified Torque: 20 lb-ft (27 Nm)

26. An insulation test is required on the HV cables any time service is performed to confirm that no voltage leaks are present in the electrical insulation of the cables. Measure the insulation resistance from the U-Phase to ground, the V-Phase to ground, and the W-Phase to ground. Make certain that the insulation resistance is 10 Mega ohms or greater.

NOTICE: Never measure insulation resistance between each phase (U, W, and V) terminal of three-phase cable connector side. See Figure 2, below.

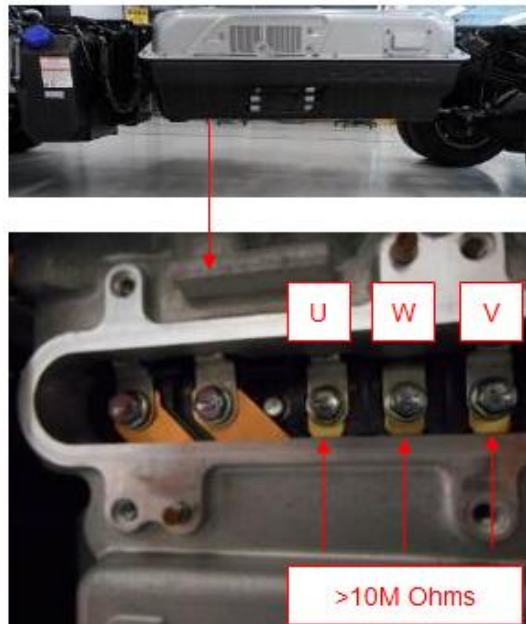

WARNING: ALWAYS use high voltage safety gloves during this step. Failure to wear high voltage safety gloves may result in personal injury or death due to electrical shock.

SAFETY RECALL

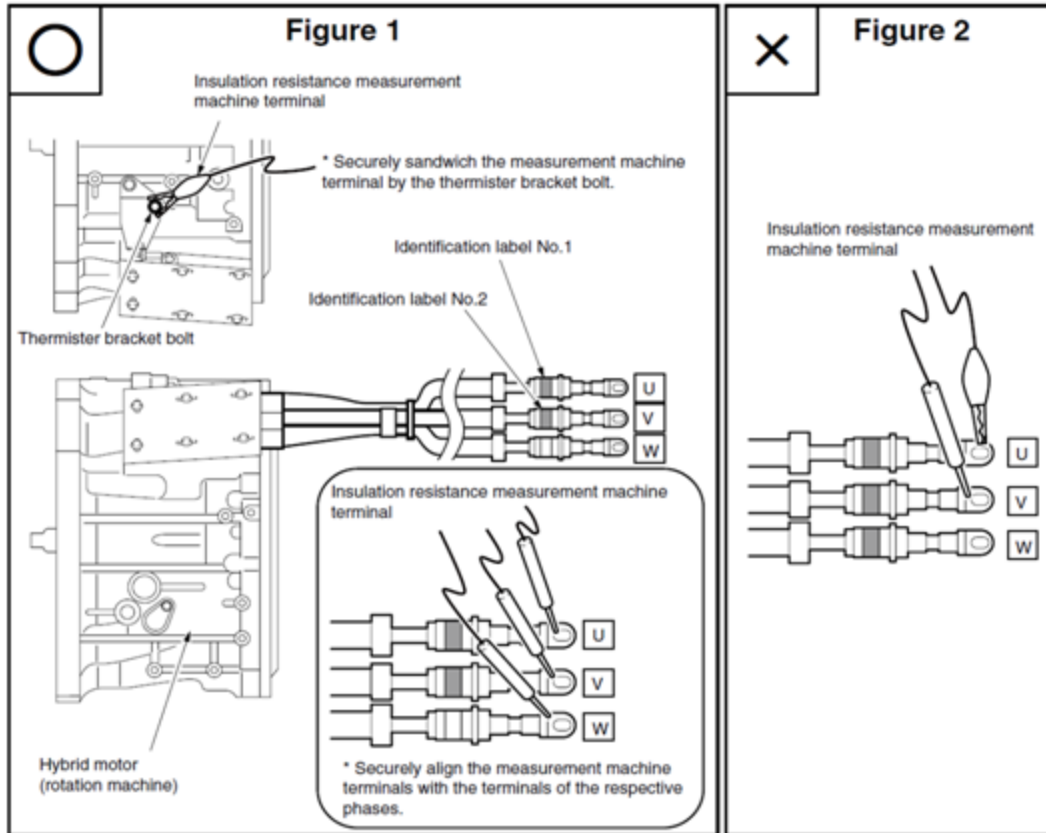

27. Install the inverter access cover using the 4 bolts that were previously removed. Tighten the bolts to the specified torque.

Specified Torque: 7 lb-ft (9 Nm)

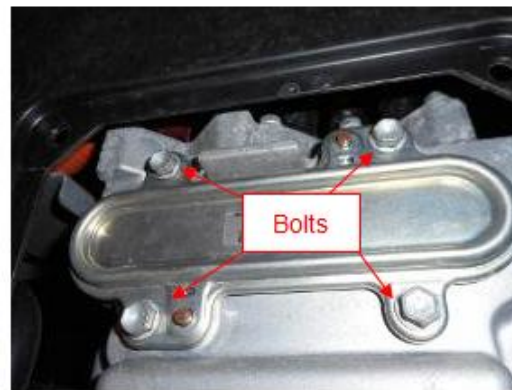

SAFETY RECALL

28. Install the plastic cover over the inverter using the 4 clips which were previously removed.

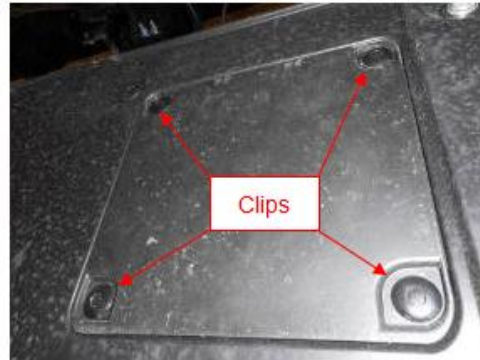

29. Connect the negative terminal of the 12 volt battery.

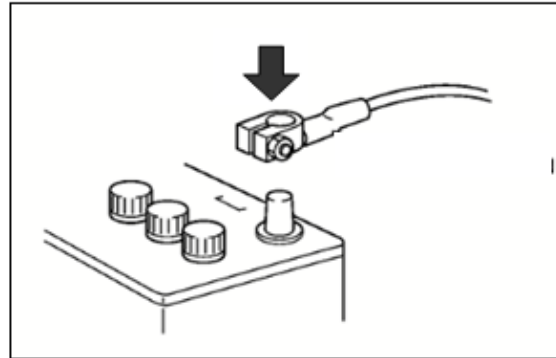

30. Remove the service plug cover. Install the service plug into the HV battery. Ensure that the locking lever is fully engaged and is slid towards the rear of the vehicle. Install the 4 bolts into the service plug cover. Tighten the bolts to the specified torque.

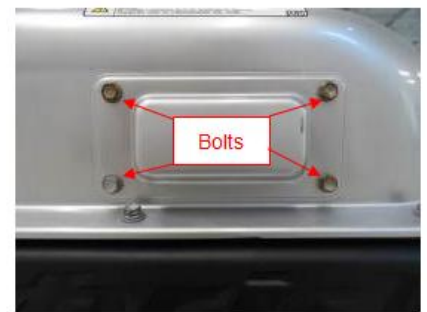

Specified Torque: 7 lb-ft (9 Nm)

NOTICE: Double check the torque of the HV circuit terminals, and verify that no loose parts or tools have been left behind prior to installing the service plug.

S A F E T Y R E C A L L

31. Verify that all connections are secure and all nuts and bolts which were removed have been tightened to their specified torque. Start and idle the engine. Verify that there are no fluid leaks, abnormal noises, or malfunction indicator lamps illuminated on the instrument panel.

32. Check the automatic transmission fluid (ATF) level.

Be sure to check the ATF level twice, when the ATF is cold, and when it is hot, for an accurate measurement.

Follow the ATF level inspection procedure provided in the Workshop Manual or the Owner's Manual.

Once the fluid level is correct, turn the ignition to the OFF "LOCK" position.

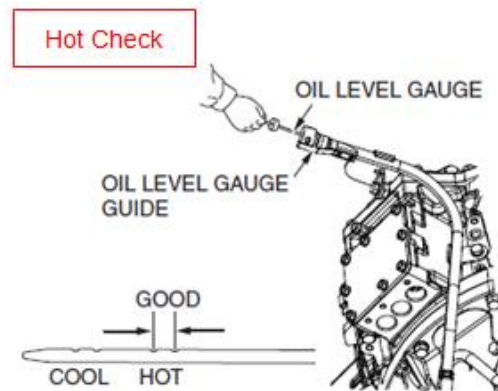
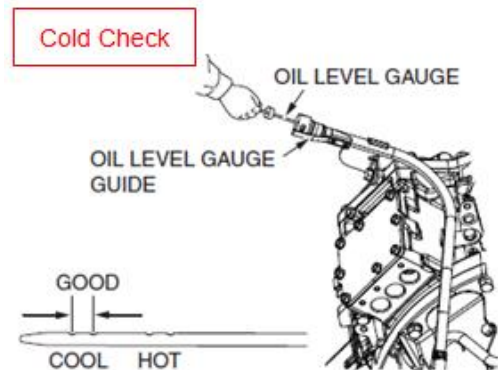

S A F E T Y R E C A L L

CREW CAB- ENGINE COVER INSTALLATION PROCEDURE

NOTE: This procedure does not apply to single cab vehicles. For single cab vehicles, proceed to the final inspection procedure, below.

1. Set the rear engine cover in place.
Install the 12 bolts on the rear engine cover. Tighten to the specified torque.

Specified Torque: 3.7 lb-ft (5.0 Nm).

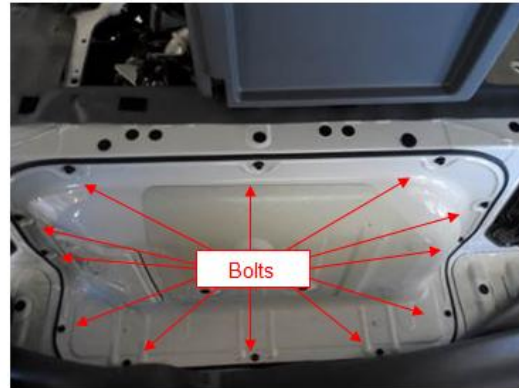

2. Set the upper cover in place. Clip in all of the snaps on the upper rubber cover.



3. Set the rear rubber floor cover in place. Clip in the 4 snaps at the front of the rear floor cover. Proceed to the final inspection procedure, below.

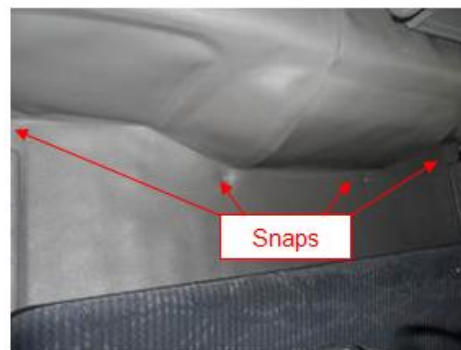

S A F E T Y R E C A L L

FINAL INSPECTION PROCEDURE

1. To complete this Recall Bulletin, review the bulletin and confirm the following:
 - All nuts and bolts have been tightened to their specified torque.
 - No fluid leaks are present.
 - The transmission and HV motor fluid levels have been checked.
 - No malfunction warning indicators are illuminated on the instrument panel.
 - The parking brake is working properly.
 - The vehicle has been road tested, and no abnormal noises or vibrations are present.
 - The high voltage warning label has been affixed to the HV motor terminal cover and will be seen by anyone trying to remove the HV motor terminal cover.

CLAIM APPLICATION:

*** Reimbursable in accordance within the terms and policies of the Hino Truck limited warranties.**

HV Motor Replacement:

a) Campaign No: A9930

b) Labor charge based on the following table:

	Single Cab Vehicles: 7.3 Hr.
	Crew Cab Vehicles: 8.1 Hr.

c) Warranty code: 87141

d) Trouble code: 98

d) Operation code: 87150AOT

e) Original failed part: G110037050