

Subject: Exhaust Discharge Location

Models Affected: Specific Freightliner Business Class M2 and Cascadia vehicles manufactured June 2, 2011, through October 29, 2014, and equipped with CNG fuel tanks.

General Information

IMPORTANT: Due to the small number of vehicles in this campaign, the vehicle serial number is required when ordering the kit and parts listed in **Table 1**.

Daimler Trucks North America LLC, on behalf of its Freightliner Trucks Division, has decided that a defect that relates to motor vehicle safety exists on the vehicles mentioned above.

There are approximately 65 vehicles involved in this campaign.

Certain compressed natural gas (CNG) powered vehicles were built with the exhaust tailpipe terminating under the CNG tank cabinet. Over time, continual heating of fuel system components by the exhaust discharge may increase the risk of fire.

A tailpipe extension will be installed to move the exhaust termination beyond the end of the CNG tank cabinet.

Additional Repairs

Dealers must complete all outstanding Recall and Field Service campaigns prior to the sale or delivery of a vehicle. A Dealer will be liable for any progressive damage that results from its failure to complete campaigns before sale or delivery of a vehicle.

Owners may be liable for any progressive damage that results from failure to complete campaigns within a reasonable time after receiving notification.

Work Instructions

Please refer to the attached work instructions. Prior to performing the campaign, check the vehicle for a completion sticker (Form WAR260).

Replacement Parts

Replacement parts are now available and can be obtained by ordering the kit and part number(s) listed in Table 1. from your facing Parts Distribution Center.

If our records show your dealership has ordered any vehicles involved in campaign number FL671A-G, a list of the customers and vehicle identification numbers will be available in OWL. Please refer to this list when ordering parts for this recall.

Recall Campaign

February 2015
FL671A-G
NHTSA #14V-680
Transport Canada #14-547

Table 1 - Replacement Parts for FL671A-G

IMPORTANT: Due to the small number of vehicles in this campaign, the vehicle serial number is required when ordering the kit and parts listed in **Table 1**.

NOTE: Vehicles requiring two Hardware Kits will have extra parts that can be discarded (two band clamps and one o-ring).

Campaign Number	Part Description	Part Number	Qty.
FL671A (4 vehicles)	Hardware Kit (see Table 2 for kit contents)	25-FL671-000	2 ea
	PIPE CTLST OUT-NAT GAS-44 IN	04-31956-044	1 ea
	BRKT-EXH,HORZ TLPP SUPT,P3 NG	04-28222-001	2 ea
FL671B (18 vehicles)	Hardware Kit (see Table 2 for kit contents)	25-FL671-000	2 ea
	PIPE CTLST OUT-NAT GAS-42 IN	04-31956-042	1 ea
	BRKT-EXH,HORZ TLPP SUPT,P3 NG	04-28222-001	2 ea
FL671C (18 vehicles)	Hardware Kit (see Table 2 for kit contents)	25-FL671-000	2 ea
	PIPE CTLST OUT-NAT GAS-42 IN	04-31956-042	1 ea
	BRKT-EXH,HORZ TLPP SUPT,P3 NG	04-28222-002	2 ea
FL671D (6 vehicles)	Hardware Kit (see Table 2 for kit contents)	25-FL671-000	1 ea
	PIPE CTLST OUT-NAT GAS-25 IN	04-31956-025	1 ea
	BRKT-EXH,HORZ TLPP SUPT,P3 NG	04-28222-001	1 ea
FL671E (2 vehicles)	Hardware Kit (see Table 2 for kit contents)	25-FL671-000	1 ea
	PIPE CTLST OUT-NAT GAS-20 IN	04-31956-020	1 ea
	BRKT-EXH,HORZ TLPP SUPT,5"	04-28222-000	1 ea
FL671F (15 vehicles)	Hardware Kit (see Table 2 for kit contents)	25-FL671-000	1 ea
	PIPE CTLST OUT-NAT GAS-15 IN	04-31956-015	1 ea
	BRKT-EXH,HORZ TLPP SUPT,5"	04-28222-002	1 ea
FL671G (1 vehicle)	PIPE CTLST OUT-NAT GAS-10 IN	04-31956-010	1 ea
	CLAMP-BND,5IN,PLN,ACCUSEAL	ABP N35 100725	2 ea
	O-RING NITRILE	PH 2014N1490	1 ea
	Blank Red Completion Sticker	WAR260	1 ea

Table 1

NOTE: Do NOT order from Table 2. The kit contents listed below are for information only. When ordering the Hardware Kit, please order kit number 25-FL671-000 and the quantity specified above in **Table 1**.

25-FL671-000 Hardware Kit Contents

Part Description	Part Number	Qty. per Kit
CLAMP-SDL,5"PLN,3/8-16 NUTS	CI U500F1	1 ea
WASHER-HRDN,0.69X1.31X.177,ZN	23-09114-000	4 ea
SCREW-CAP,HEX5/8-11X2.25 GR8PO	23-09444-225	2 ea
NUT-HEX,PT,5/8-11,C,ZN/AL	23-13833-110	2 ea
O-RING NITRILE	PH 2014N1490	1 ea
CLAMP-BND,5IN,PLN,ACCUSEAL	ABP N35 100725	2 ea
Blank Red Completion Sticker	WAR260	1 ea

Table 2

Removed Parts

U.S. and Canadian Dealers, please follow Warranty Failed Parts Tracking shipping instructions for the disposition of all removed parts. Export distributors, please destroy removed parts unless otherwise advised.

Labor Allowance

Table 3 - Labor Allowance

Campaign Number	Procedure	Time Allowed (hours)	SRT Code	Corrective Action
FL671A-C	Install extension pipe and two brackets	3.4 Cascadia	996-0944C	12-Repair Recall/Campaign
		2.4 M2		
FL671D-F	Install extension pipe and one bracket	2.7 Cascadia	996-0944B	
		1.8 M2		
FL671G	Install extension pipe with no brackets	0.5 M2	996-0944A	

Table 3

IMPORTANT: When the Recall has been completed, locate the base completion label in the appropriate location on the vehicle, and attach the red completion sticker provided in the recall kit (Form WAR260). If the vehicle does not have a base completion label, clean a spot on the appropriate location of the vehicle and first attach the base completion label (Form WAR259). If a recall kit is not required or there is no completion sticker in the kit, write the recall number on a blank sticker and attach it to the base completion label.

Claims for Credit

You will be reimbursed for your parts, labor, and handling (landed cost for Export Distributors) by submitting your claim through the Warranty system within 30 days of completing this campaign. Please reference the following information in OWL:

- Claim type is **Recall Campaign**.
- In the Campaign field, enter the campaign number and appropriate group (e.g. **FL671-A, FL671-B, etc.**).
- In the Primary Failed Part field, enter **25-FL671-000**.

Recall Campaign

Daimler Trucks
North America LLC

February 2015
FL671A-G
NHTSA #14V-680
Transport Canada #14-547

- In the Parts section, enter the appropriate kit and part number(s) as shown in the Replacement Parts Table.
IMPORTANT: Due to the small number of vehicles in this campaign, the vehicle serial number is required when ordering the kit and parts listed in **Table 1**.
- In the Labor section, enter the appropriate SRT from the Labor Allowance Table. Administrative time will be included automatically as SRT 939-6010A for 0.3 hours.
- The VMRS Component Code is **043-003-012** and the Cause Code is **A1 - Campaign**.
- **U.S. and Canada – Reimbursement for Prior Repairs.** When a customer asks about reimbursement, please do the following:
 - Accept the documentation of the previous repair.
 - Make a brief check of the customer's paperwork to see if the repair may be eligible for reimbursement. (See the "Copy of Owner Letter" section of this bulletin for reimbursement guidelines.)
 - Submit an OWL Recall Pre-Approval Request for a decision.
 - Attach the documentation to the pre-approval request.
 - If approved, submit a based on claim for the pre-approval.
 - Reimburse the customer the appropriate amount.

IMPORTANT: OWL must be viewed prior to performing the recall to ensure the vehicle is involved and the campaign has not been previously completed. Also, check for a completion sticker prior to beginning work.

For questions, U.S. and Canadian dealers, contact the Warranty Campaigns Department from 7:00 a.m. to 4:00 p.m. Pacific Time, Monday through Friday, via Web inquiry at AccessFreightliner.com / Support / My Tickets and Submit an Inquiry, or the Customer Assistance Center at (800) 385-4357, after normal business hours, if you have any questions or need additional information. Export distributors, submit a Web inquiry or contact your International Service Manager.

U.S. and Canadian Dealers: To return excess kit inventory related to this campaign, U.S. dealers must submit a Parts Authorization Return (PAR) to the Memphis PDC. Canadian dealers must submit a PAR to their facing PDC. All kits must be in resalable condition. PAR requests must include the original purchase invoice number. Export Distributors: Excess inventory is not returnable.

The letter notifying U.S. and Canadian vehicle owners is included for your reference.

Please note that the National Traffic and Motor Vehicle Safety Act, as amended (Exhaust Discharge Location 49, United States Code, Chapter 301), requires the owner's vehicle(s) be corrected within a reasonable time after parts are available to you. The Act states that failure to repair a vehicle within 60 days after tender for repair shall be prima facie evidence of an unreasonable time. However, circumstances of a particular situation may reduce the 60 day period. Failure to repair a vehicle within a reasonable time can result in either the obligation to (a) replace the vehicle with an identical or reasonably equivalent vehicle, without charge, or (b) refund the purchase price in full, less a reasonable allowance for depreciation. The Act further prohibits dealers from selling a vehicle unless all outstanding recalls are performed. Any lessor is required to send a copy of the recall notification to the lessee within 10 days. Any subsequent stage manufacturer is required to forward this notice to its distributors and retail outlets within five working days.

Copy of Notice to Owners

Subject: Exhaust Discharge Location

For the Notice to U.S. Customers: This notice is sent to you in accordance with the requirements of the National Traffic and Motor Vehicle Safety Act.

For the Notice to Canadian Customers: This notice is sent to you in accordance with the Canadian Motor Vehicle Safety Act.

Daimler Trucks North America LLC, on behalf of its Freightliner Trucks Division, has decided that a defect which relates to motor vehicle safety exists on specific Freightliner Business Class M2 and Cascadia vehicles manufactured June 2, 2011, through October 29, 2014, and equipped with CNG fuel tanks.

Certain compressed natural gas (CNG) powered vehicles were built with the tailpipe terminating under the CNG tank cabinet. Over time, continual heating of fuel system components by the exhaust discharge may increase the risk of fire.

A tailpipe extension will be installed to move the exhaust termination beyond the end of the CNG tank cabinet.

Please contact an authorized Daimler Trucks North America dealer to arrange to have the Recall performed and to ensure that parts are available at the dealership. To locate an authorized dealer, search online at www.Daimler-TrucksNorthAmerica.com / Contact Us / Find a Dealer. The Recall will take approximately one to four hours, depending on the repair, and will be performed at no charge to you.

You may be liable for any progressive damage that results from your failure to complete the Recall within a reasonable time after receiving notification.

If you do not own the vehicle that corresponds to the identification number(s) which appears on the Recall Notification, please return the notification to the Warranty Campaigns Department with any information you can furnish that will assist us in locating the present owner. If you have leased this vehicle, Federal law requires that you forward this notice to the lessee within 10 days. If you are a subsequent stage manufacturer, Federal law requires that you forward this notice to your distributors and retail outlets within five working days. If you have paid to have this recall condition corrected prior to this notice, you may be eligible to receive reimbursement. Please see the reverse side of this notice for details.

For the Notice to U.S. Customers: If you have questions about this Recall, please contact the Warranty Campaigns Department at (800) 547-0712, 7:00 a.m. to 4:00 p.m. Pacific Time, Monday through Friday, e-mail address DTNA.Warranty.Campaigns@Daimler.com, or the Customer Assistance Center at (800) 385-4357 after normal business hours. If you are not able to have the defect remedied without charge and within a reasonable time, you may wish to submit a complaint to the Administrator, National Highway Traffic Safety Administration, 1200 New Jersey Avenue, SE., Washington, DC 20590; or call the Vehicle Safety Hotline at (888) 327-4236 (TTY: 800-424-9153); or to <http://www.safercar.gov>.

For the Notice to Canadian Customers: If you have questions about this Recall, please contact the Warranty Campaigns Department at (800) 547-0712, 7:00 a.m. to 4:00 p.m. Pacific Time, Monday through Friday, e-mail address DTNA.Warranty.Campaigns@Daimler.com, or the Customer Assistance Center at (800) 385-4357 after normal business hours.

We regret any inconvenience this action may cause but feel certain you understand our interest in motor vehicle safety.

WARRANTY CAMPAIGNS DEPARTMENT

Enclosure

February 2015
FL671A-G
NHTSA #14V-680
Transport Canada #14-547

Reimbursement to Customers for Repairs Performed Prior to Recall

If you have already **paid** to have this recall condition corrected you may be eligible to receive reimbursement.

Requests for reimbursement may include parts and labor. Reimbursement may be limited to the amount the repair would have cost if completed by an authorized Daimler Trucks North America LLC dealer. The following documentation must be presented to your dealer for consideration for reimbursement.

Please provide original or clear copies of all receipts, invoices, and repair orders that show

- The name and address of the person who paid for the repair
- The Vehicle Identification Number (VIN) of the vehicle that was repaired
- What problem occurred, what repair was done, when the repair was done
- Who repaired the vehicle
- The total cost of the repair expense that is being claimed
- Proof of payment for the repair (such as the front and back of a cancelled check or a credit card receipt)

Reimbursement will be made by check from your Daimler Trucks North America LLC dealer.

Please speak with your Daimler Trucks North America LLC authorized dealer concerning this matter.

Work Instructions

Subject: Exhaust Discharge Location

Models Affected: Specific Freightliner Business Class M2 and Cascadia vehicles manufactured June 2, 2011, through October 29, 2014, and equipped with CNG fuel tanks.

IMPORTANT: Due to the small number of vehicles in this campaign, the vehicle serial number is required when ordering the kit and parts listed in **Table 1**.

NOTE: Vehicles requiring two Hardware Kits will have extra parts that can be discarded (two band clamps and one o-ring).

Exhasut Pipe Installation

1. Check the base label (Form WAR259) for a completion sticker for FL671 (Form WAR260) indicating this work has been done. The base label is usually located on the passenger-side door about 12 inches (30 cm) below the door latch. If a sticker is present, no work is needed. If there is no sticker, proceed to the next step.
2. Park the vehicle on a level surface, shut down the engine, and set the parking brake. Chock the tires.

 **WARNING**

Read and understand the Safety Precautions in Subject 47.04, 100 of the *Cascadia Workshop Manual* before working on the Compressed Natural Gas (CNG) system. Failure to follow the prescribed safety precautions could lead to fire, explosion, property damage, and/or personal injury.

3. Remove the existing exhaust pipe and mitigator. Save the mitigator for reinstallation. Discard the clamps and pipe.
4. Vehicles in FL671A-C require two hanger brackets. Refer to **Fig. 1** on page 8 for installation, then proceed to step 5 on page 10.

Vehicles in FL671D-F require one hanger bracket. Refer to **Fig. 2** on page 9 for installation, then proceed to step 5 on page 10.

Vehicles in FL671G do not require a hanger bracket. Refer to **Fig. 3** on page 10, then proceed to step 9 on page 11 for installing the tailpipe extension.

Recall Campaign

Daimler Trucks
North America LLC

February 2015
FL671A-G
NHTSA #14V-680
Transport Canada #14-547

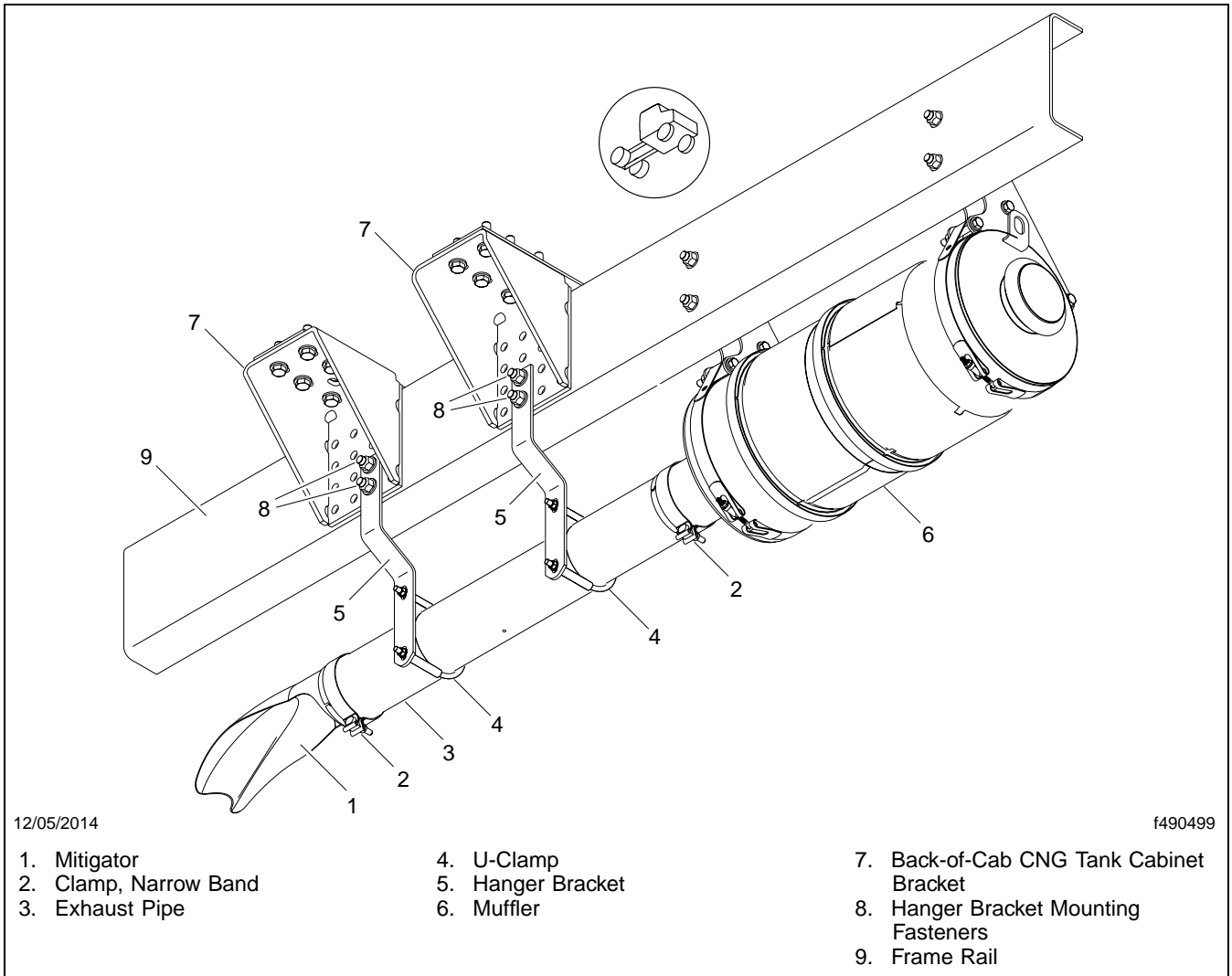

Fig. 1, Exhaust Pipe Installation, Two Hangers

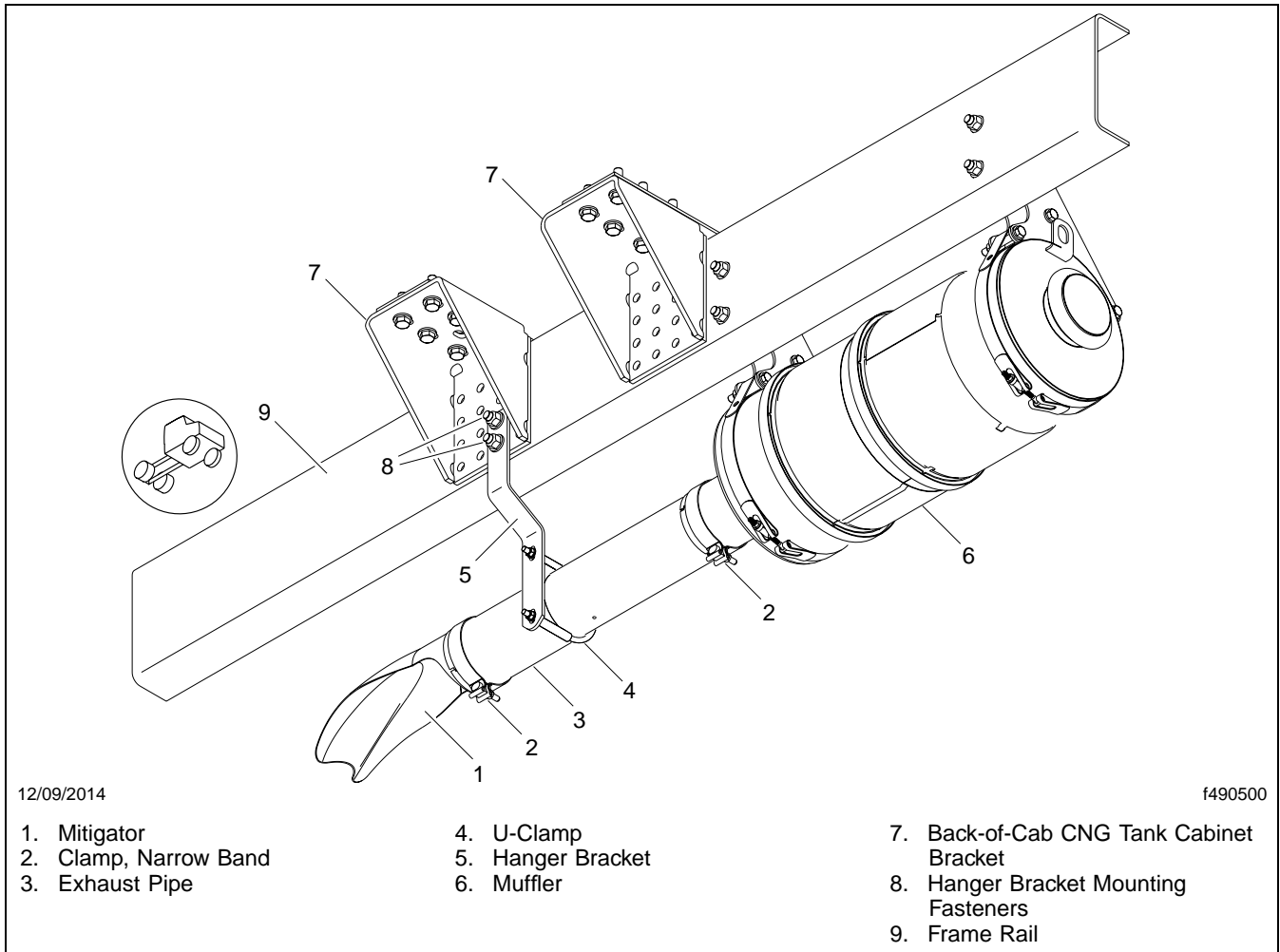

Fig. 2, Exhaust Pipe Installation, One Hanger

February 2015
FL671A-G
NHTSA #14V-680
Transport Canada #14-547

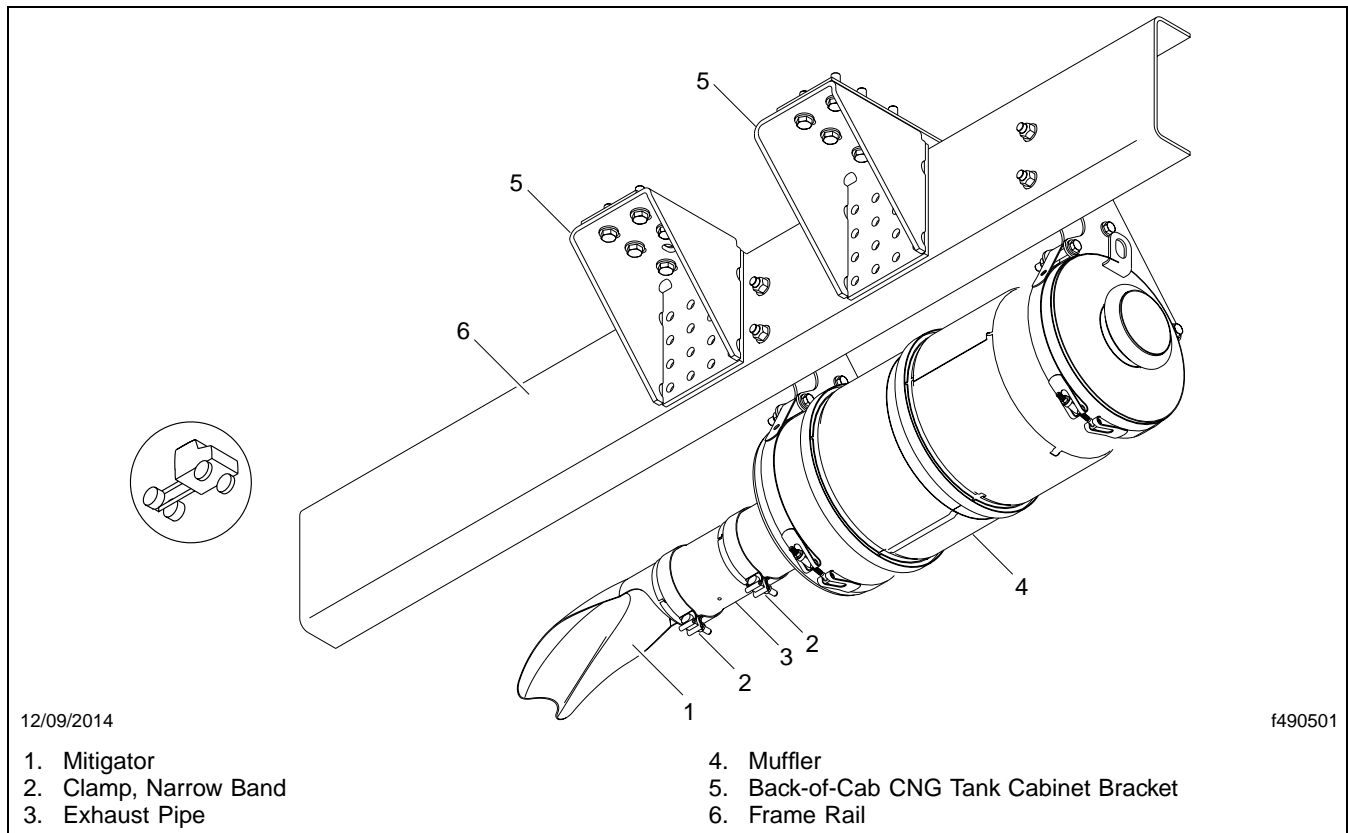

Fig. 3, Exhaust Pipe Installation, No Hangers

5. In some cases, when adding the extra exhaust bracket(s), the right side frame-rail-mounted CNG tank may need to be removed to gain access. For instructions, refer to **Section 47.04** of the *Cascadia Workshop Manual*.

IMPORTANT: The preferred location for the new hanger bracket(s) is in existing holes in the frame rail. Usually, two of the central lower holes used to mount the back-of-cab CNG tank cabinet mounting bracket will work best. Choose the hole locations with the best access from both sides of the frame rail. If needed, additional holes must be drilled. If drilling holes anywhere else, follow the "Drilling Holes" guidelines in **Subject 31.00, 100** of the *Cascadia Workshop Manual*.

6. Determine the best location for the hanger bracket(s). Where possible, use the existing holes in the back-of-cab tank cabinet mounting bracket(s). See **Fig. 4**.
7. Using the existing holes in the back-of-cab CNG tank cabinet mounting bracket as a guide, drill additional holes in the frame rail as needed to mount the hanger brackets.
8. Install the required hanger bracket(s) using the nuts, bolts, and washers from the hardware kit. Tighten the mounting nuts and bolts 128 lbf-ft (173 N·m).

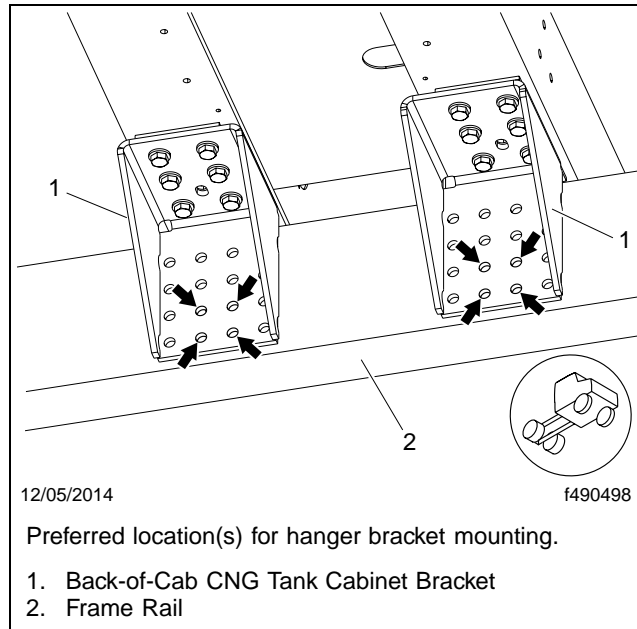

Fig. 4, Determining the Hanger Locations

9. Install the mitigator on the new pipe using the band clamps from the hardware kit. Tighten the clamps 35 to 47 lbf·ft (47 to 64 N·m).
10. Position the pipe and mitigator assembly on the muffler, supporting the rear of the pipe as needed.
11. Orient the pipe and mitigator assembly to the hanger brackets and orient the mitigator outlet facing the ground. Install the U-clamps from the hardware kit. See **Fig. 1**. Tighten the clamp nuts 20 to 26 lbf·ft (27 to 35 N·m).
12. Tighten the clamp at the muffler 35 to 47 lbf·ft (47 to 64 N·m).
13. If removed, install the right side frame-rail-mounted CNG tank. For instructions, refer to **Section 47.04** of the *Cascadia Workshop Manual*.
14. Clean a spot on the base label (Form WAR259). Write the campaign number, FL671, on a blank red completion sticker (Form WAR260) to indicate the work has been completed and attach it to the base label.