



# Recall Bulletin



## F/CMVSS NONCOMPLIANCE RECALL

**SUBJECT:** Loss of Driver Door Master Window Function due to Damaged Splice

**MODELS:** 2014 Buick LaCrosse

This bulletin has been revised to include a copy of the customer letter, correct the special tool number of the Ultratorch, and to emphasize that the production date listed on the harness tag is in the month/day/year format. Please discard all copies of 14235.

It is a violation of Federal law for a dealer to deliver a new motor vehicle or any new or used item of motor vehicle equipment (including a tire) covered by this notification under a sale or lease until the defect or noncompliance is remedied.

Vehicles involved in this recall were placed on stop delivery June 4, 2014. Once the service procedure contained in this bulletin has been performed on the vehicle, the vehicle is released from stop delivery and the vehicle can be delivered to the customer.

All involved vehicles that are in dealer inventory must be held and not delivered to customers, dealer traded, or used for demonstration purposes until the repair contained in this bulletin has been performed on the vehicle.

### CONDITION

General Motors has decided that certain 2014 model year Buick LaCrosse model vehicles fail to conform to Federal/Canada Motor Vehicle Safety Standards 114, Theft Protection and Rollaway Prevention, and/or 118, Power-Operated Window, Partition, and Roof Panel Systems.

An unsealed wiring splice in the driver's door may corrode and break, which may communicate incorrect information to circuits that control the door chime and Retained Accessory Power (RAP). When the ignition key is turned off and the driver's door is opened, the RAP may stay active for 10 minutes. The passenger window, rear door windows, and sunroof (if equipped) could be operated during this 10 minute period. If the vehicle has a keyed ignition switch on the steering column, the door chime may not sound if the key is left in the ignition and the driver's door is opened.

If the passenger windows, rear windows, and sunroof (if equipped) can function when the vehicle is turned off and the driver is not in the vehicle, there is risk of injury if unsupervised occupants operate the power closures.

If a chime does not sound when the key is in the ignition and the driver's door is opened, there is a risk that the key may be left in the ignition and theft of the vehicle is possible.

### CORRECTION

Dealers are to inspect the driver door window motor harness and if necessary, replace an electrical splice.

### VEHICLES INVOLVED

All involved vehicles are identified by Vehicle Identification Number on the Investigate Vehicle History screen in GM Global Warranty Management system. Dealership service personnel should always check this site to confirm vehicle involvement prior to beginning any required inspections and/or repairs. It is important to routinely use this tool to verify eligibility because not all similar vehicles may be involved regardless of description or option content.

For dealers with involved vehicles, a listing with involved vehicles containing the complete vehicle identification number, customer name, and address information has been prepared and will be provided to US and Canadian dealers through the GM GlobalConnect Recall Reports. Dealers will not have a report available if they have no involved vehicles currently assigned.

The listing may contain customer names and addresses obtained from Motor Vehicle Registration Records. The use of such motor vehicle registration data for any purpose other than follow-up necessary to complete this recall is a violation of law in several states/provinces/countries. Accordingly, you are urged to limit the use of this report to the follow-up necessary to complete this recall.

### PART INFORMATION

Parts required to complete this recall are to be obtained from General Motors Customer Care and Aftersales (GMCC&A). Please refer to your "involved vehicles listing" before ordering parts. Normal orders should be placed on a DRO = Daily Replenishment Order. In an emergency situation, parts should be ordered on a CSO = Customer Special Order.

<b>Part Number</b>	<b>Description</b>	<b>Quantity/Vehicle</b>
05297428	CLIP, WRG HARN SPLICE (merch pk of 10)	2
12355010	TUBING, SHRINK (1/8" BLACK) (merch pk of 10)	1
Obtain Locally	WIRE, JUMPER (.800 mm / 18 Gauge)	As Req'd (Submit as Net Item)
*1089482	Woven Polyester Electrical Tape (PET)	As Req'd (Submit in Net Item)

\* To obtain the PET, contact Kent Automotive at 1-888-937-5368 or [www.kent-automotive.com](http://www.kent-automotive.com) and request the special order part number 1089482. **Do not order from GMCCA.**

SERVICE PROCEDURE**Inspection Procedure**

1. Position the driver window to the fully closed position.
2. Turn the ignition key off.

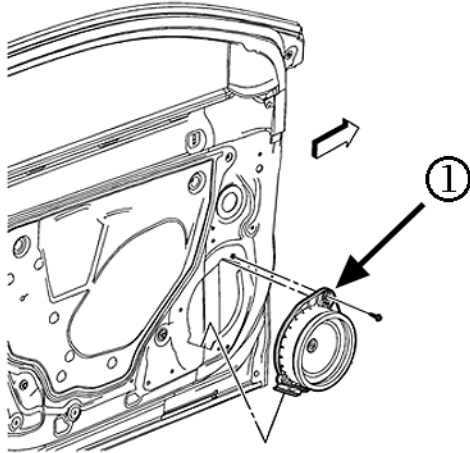

3926780

3. Remove the driver door trim panel and the front speaker (1). Refer to *Radio Front Side Door Speaker Replacement* in SI.

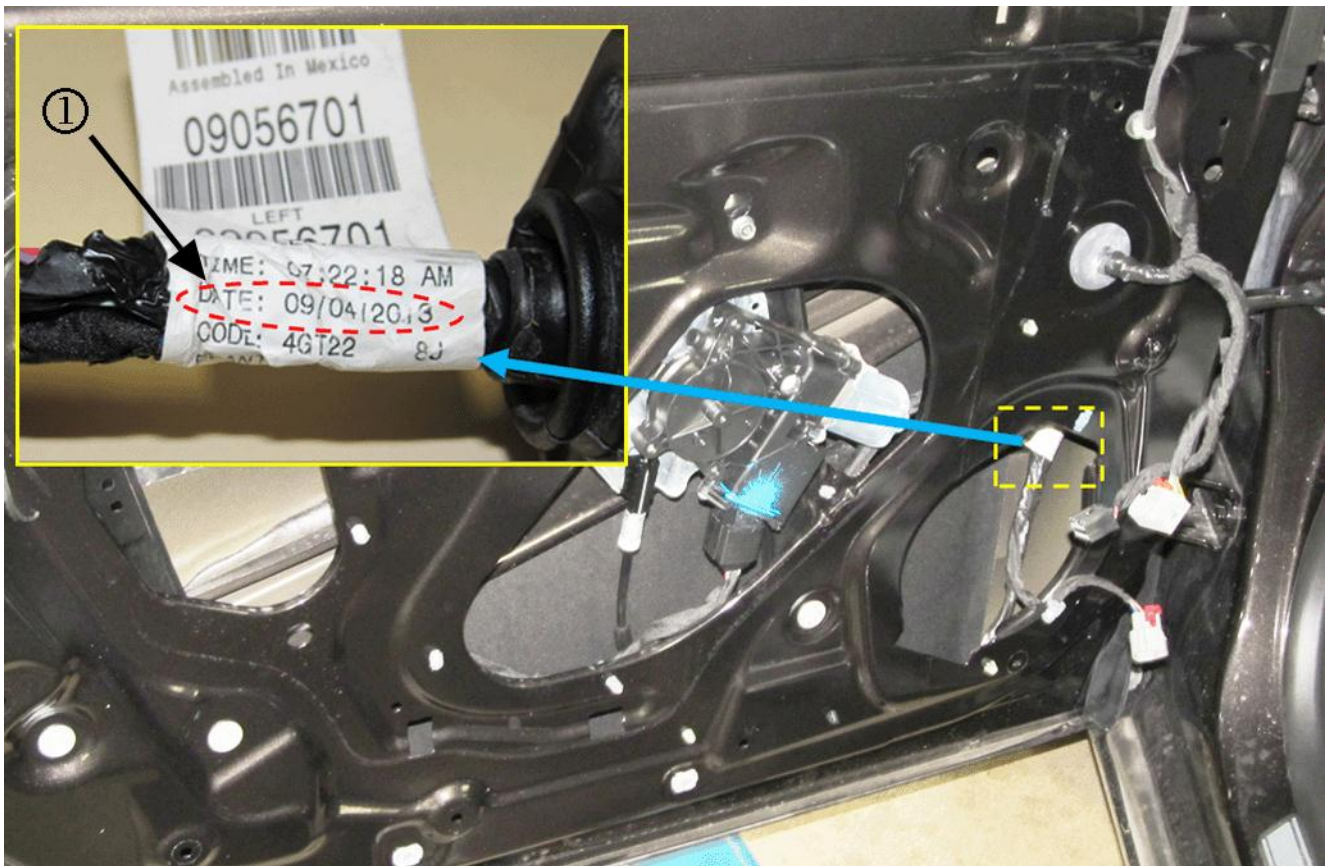

3926783

4. Insert an inspection mirror into the speaker opening and inspect the door wiring harness for a parts tag, which includes a production date (1) listed in the month/day/year format.
  - If the date on the harness tag is prior to October 2, 2013 (10/02/2013 on tag), the door wiring harness DOES contain the splice failure issue and you should move directly to the *Wiring Repair Service Procedure*.
  - If the date on the harness tag is not prior to October 2, 2013 (10/02/2013 on tag), no further action is required. Reinstall the front speaker and driver door trim panel; Refer to *Radio Front Side Door Speaker Replacement in SI*.

## Wiring Repair Service Procedure

### Tools Required

- J-38125-8, Splice Sleeve Crimp Tool
  - J-38125-5A, Ultratorch, or equivalent butane fueled soldering iron
1. Remove the driver door water deflector.



3926785

2. Disconnect the door electrical connector (1) at the A-pillar and unseat the harness grommet (2) from the door sheet metal. Note the location of splice J501 (3).
3. Detach the window motor harness wiring from the door and pull the harness through the center sheet metal opening.

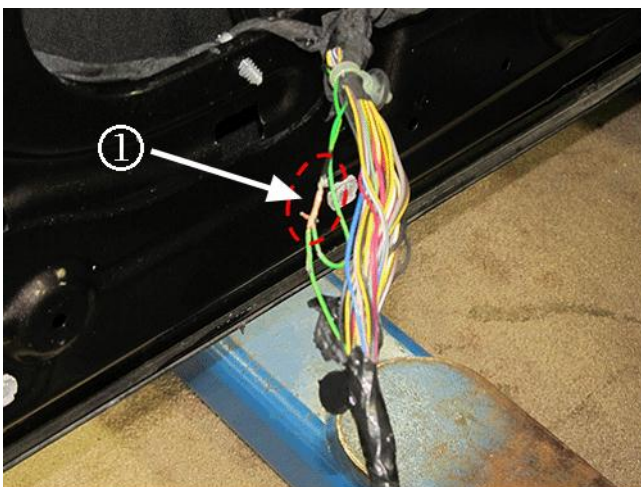

3926786

4. Carefully remove enough conduit and tape from the harness to locate and access splice J501 (1).



3926788

**Note:** If no corrosion is found, remove enough wiring to completely remove the splice.

5. Inspect the splice area for any surrounding corrosion. Cut out a section of the wire to remove the splice and any corrosion found.
6. Strip off approximately 10mm (0.40 in) of insulation from the three wire ends and twist the two cut wires coming from the harness end together.
7. Install two 38 mm (1.5 in) sections of heat shrink tube; one onto the two wires twisted together and the other onto the single wire.

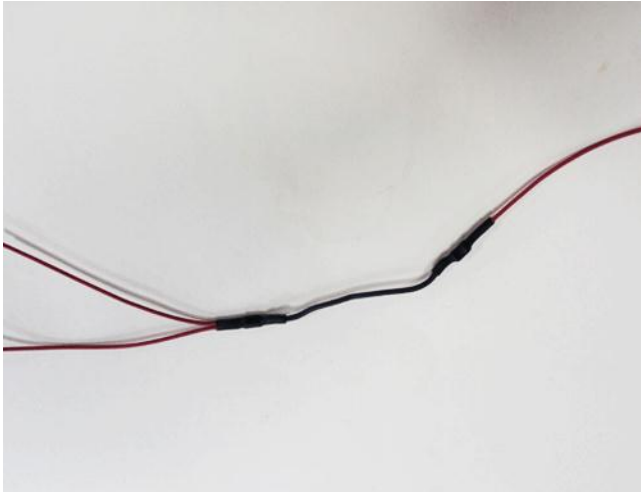

3926787

**Note:** The graphic above is an off-vehicle example of the completed jumper repair.

**Caution:** .800 mm (18 gauge) wire is recommended as the jumper in order to help maintain the integrity of the splice crimp.

8. Add an appropriate length jumper wire, obtained locally.
  - 8.1 Strip off approximately 10mm (0.40 in) of insulation from each end of the jumper wire.
  - 8.2 Fold over one end of the jumper wire and position it together with the twisted wires.

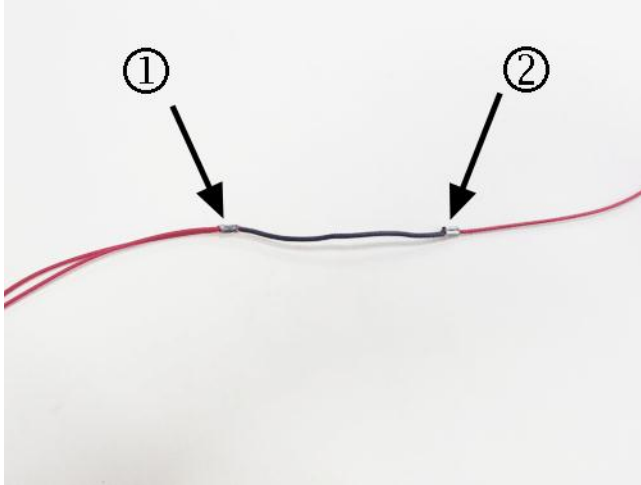

3926789

- 8.3 Crimp a splice clip (1) over the three wires using Special Tool J-38125-8, nest F. Verify the crimp quality.
- 8.4 Fold over the other end of the jumper wire and position it together with the folded end of the remaining single wire.
- 8.5 Crimp a splice clip (2) over the two wires using Special Tool J-38125-8, nest F. Verify the crimp quality.

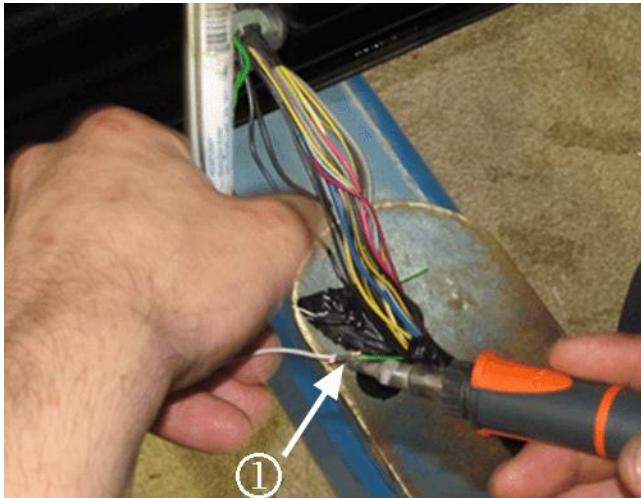

3926790

**Caution:** Keep the heat shrink tube above the splice when soldering the splice to ensure that the heat shrink is not prematurely shrunk and closed down over the wire or splice area due to the heat from the soldering iron.

**Warning:** DO NOT use soldering equipment that is battery or electric powered. These types of soldering irons can induce voltage into the circuit, which may cause inflator module deployment and/or damage to electrical components. Use only the J-38125-5A Ultratorch or another butane fueled soldering iron when working on SIR circuits.

9. Solder the crimps and splice clips (1) using the Ultratorch, part number J-38125-5A, or another butane fueled soldering iron.

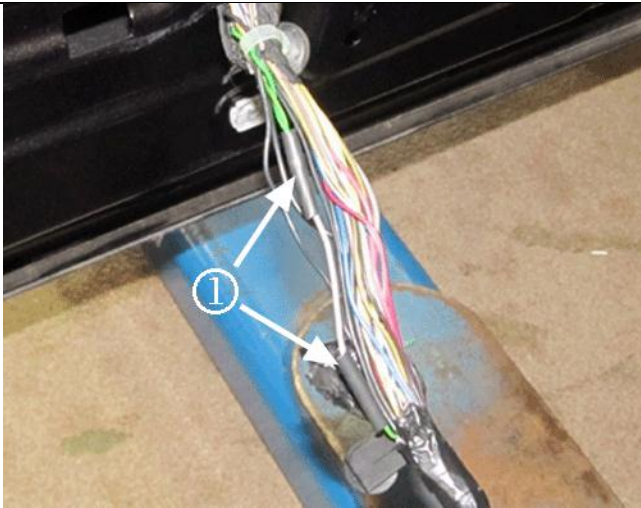

3926791

**Caution:** For maximum protection against water intrusion, ensure the heat shrink on the two wire splice shrinks tight and extends a length down the two wires.

10. Center the heat shrink tubes (1) over each splice and shrink/seal the heat shrink tube securely over the splice crimp and insulated wires.



3926792

11. Wrap woven polyester electrical tape (PET) or equivalent anti-abrasion tape around the spliced section of the harness wires.
12. Reroute the door harness, reattach the retainers/grommet to the door and reconnect the door harness electrical connector.
13. Reinstall the water deflector.
14. Reinstall the front speaker and driver door trim panel; Refer to *Radio Front Side Door Speaker Replacement in SI*

#### COURTESY TRANSPORTATION – For US and Canada

The General Motors Courtesy Transportation program is intended to minimize customer inconvenience when a vehicle requires a repair that is covered by the New Vehicle Limited Warranties. The availability of courtesy transportation to customers whose vehicles are within the warranty coverage period and involved in a product program is very important in maintaining customer satisfaction. Dealers are to ensure that these customers understand that shuttle

service or some other form of courtesy transportation is available and will be provided at no charge. Dealers should refer to the General Motors Service Policies and Procedures Manual for Courtesy Transportation guidelines.

### WARRANTY TRANSACTION INFORMATION

Submit a transaction using the table below. All transactions should be submitted as a ZFAT transaction type, unless noted otherwise.

Labor Code	Description	Labor Time	Net Item
9100622	Driver Door Window Motor Harness Inspection – No Further Action Req'd	0.4	NA
9100623	Driver Door Window Motor Harness Inspection & Wire Repair	0.8	*

- \* The amount identified in “Net Item” should represent the actual cost of the woven polyester electrical tape (PET) and jumper wire needed to perform the required repairs, not to exceed \$0.50 USD / \$0.60 CAD.

### CUSTOMER NOTIFICATION – For US and Canada

General Motors will notify customers of this recall on their vehicle.

### DEALER RECALL RESPONSIBILITY – For US and Export (US States, Territories, and Possessions)

It is a violation of Federal law for a dealer to deliver a new motor vehicle or any new or used item of motor vehicle equipment (including a tire) covered by this notification under a sale or lease until the defect or noncompliance is remedied.

The US National Traffic and Motor Vehicle Safety Act provides that each vehicle that is subject to a recall of this type must be adequately repaired within a reasonable time after the customer has tendered it for repair. A failure to repair within sixty days after tender of a vehicle is prima facie evidence of failure to repair within a reasonable time. If the condition is not adequately repaired within a reasonable time, the customer may be entitled to an identical or reasonably equivalent vehicle at no charge or to a refund of the purchase price less a reasonable allowance for depreciation. To avoid having to provide these burdensome remedies, every effort must be made to promptly schedule an appointment with each customer and to repair their vehicle as soon as possible. In the recall notification letters, customers are told how to contact the US National Highway Traffic Safety Administration if the recall is not completed within a reasonable time.

**This bulletin is notice to you that the new motor vehicles included in this recall may not comply with the standard identified above. Under Title 49, Section 30112 of the United States Code, it is illegal for a dealer to sell a new motor vehicle which the dealer knows does not comply with an applicable Federal Motor Vehicle Safety Standard. As a consequence, if you sell any of these motor vehicles without first performing the recall correction, your facility may be subject to a civil penalty for each such sale.**



## DEALER RECALL RESPONSIBILITY - All

All unsold new vehicles in dealer's possession and subject to this recall must be held and inspected/repaired per the service procedure of this recall bulletin before customers take possession of these vehicles.

Dealers are to service all vehicles subject to this recall at no charge to customers, regardless of mileage, age of vehicle, or ownership, from this time forward.

Customers who have recently purchased vehicles sold from your vehicle inventory, and for which there is no customer information indicated on the dealer listing, are to be contacted by the dealer. Arrangements are to be made to make the required correction according to the instructions contained in this bulletin. A copy of the customer letter is provided in this bulletin for your use in contacting customers. Recall follow-up cards should not be used for this purpose, since the customer may not as yet have received the notification letter.

In summary, whenever a vehicle subject to this recall enters your vehicle inventory, or is in your facility for service in the future, you must take the steps necessary to be sure the recall correction has been made before selling or releasing the vehicle.





# IMPORTANT SAFETY RECALL

August 2014

Dear General Motors Customer:

This notice is sent to you in accordance with the National Traffic and Motor Vehicle Safety Act.

General Motors has decided that certain 2014 model year Buick LaCrosse model vehicles fail to conform to Federal/Canada Motor Vehicle Safety Standards 114, Theft Protection and Rollaway Prevention, and/or 118, Power-Operated Window, Partition, and Roof Panel Systems. As a result, GM is conducting a safety recall. We apologize for this inconvenience. However, we are concerned about your safety and continued satisfaction with our products.

## IMPORTANT

- This notice applies to your GM vehicle.
- Your vehicle is involved in GM recall 14235.
- Schedule an appointment with your GM dealer.
- This service will be performed for you at **no charge**.

### Why is your vehicle being recalled?

An unsealed wiring splice in the driver's door may corrode and break, which may communicate incorrect information to circuits that control the door chime and Retained Accessory Power (RAP). When the ignition key is turned off and the driver's door is opened, the RAP may stay active for 10 minutes. The passenger window, rear door windows, and sunroof (if equipped) could be operated during this 10 minute period. If the vehicle has a keyed ignition switch on the steering column, the door chime may not sound if the key is left in the ignition and the driver's door is opened.

If the passenger windows, rear windows, and sunroof (if equipped) can function when the vehicle is turned off and the driver is not in the vehicle, there is risk of injury if unsupervised occupants operate the power closures.

If a chime does not sound when the key is in the ignition and the driver's door is opened, there is a risk that the key may be left in the ignition and theft of the vehicle is possible.

### What will we do?

Your GM dealer will inspect the driver door window motor harness and if necessary, replace an electrical splice. This service will be performed for you at **no charge**. Because of service scheduling

requirements, it is likely that your dealer will need your vehicle longer than the actual time of approximately 50 minutes.

**What should you do?**

You should contact your GM dealer to arrange a service appointment as soon as possible.

**Do you have questions?**

If you have questions or concerns that your dealer is unable to resolve, please contact the appropriate Customer Assistance Center at the number listed below.

Division	Number	Text Telephones (TTY)
Buick	1-866-608-8080	1-800-832-8425
Guam	1-671-648-8450	
Puerto Rico – English	1-800-496-9992	
Puerto Rico – Español	1-800-496-9993	
Virgin Islands	1-800-496-9994	

If after contacting your dealer and the Customer Assistance Center, you are still not satisfied we have done our best to remedy this condition without charge and within a reasonable time, you may wish to write the Administrator, National Highway Traffic Safety Administration, 1200 New Jersey Avenue, SE, Washington, DC 20590, or call the toll-free Vehicle Safety Hotline at 1.888.327.4236 (TTY 1.800.424.9153), or go to <http://www.safercar.gov>. The National Highway Traffic Safety Administration Campaign ID Number for this recall is 14V317.

Federal regulation requires that any vehicle lessor receiving this recall notice must forward a copy of this notice to the lessee within ten days.

Jim Moloney  
General Director,  
Customer and Relationship Services